

Features 產品特色

1. For RC model electrical equipment diagnostic and measurement use.
 2. High precision display of individual cell voltage for 2 to 8S lithium packs. In addition to individual cell voltage, it also displays total pack voltage as well as percentage of pack's remaining capacity.
 3. Displays serial cell count in a pack, as well as highest and lowest cell voltage, and the voltage difference.
 4. Servo diagnostic feature. Displays BEC output voltage and receiver signal output.
 5. Digital tachometer to display 2 to 7 propeller rotating speed as well as memory for highest RPM attained.
 6. Reverse polarity protection for cell input.
1. 整合遙控模型系列商品量測與檢測之多功能產品。
 2. 高精度顯示2-8S電池組每CELL電壓、總電壓與剩餘容量百分比。
 3. 顯示電池之串聯數量與最高、最低CELL電壓、壓差值。
 4. 具有伺服機測試器功能，亦可量測BEC輸出電壓與接收機輸出訊號。
 5. 量測2到7槳的螺旋槳轉速並記憶最高轉速值。
 6. CELL電壓輸入反接保護。

Safety Precautions 安全注意事項

1. Please read this instruction thoroughly before operating.
 2. Do not disassemble, modify, or subject the unit to force impact. Doing so will void warranty.
 3. Do not exert forces on the LCD display.
 4. Avoid contact with dust, humidity, rain moisture, or vibration.
 5. Keep proper distance from propeller during measurement process.
1. 在開始操作之前，請務必詳閱本說明書。
 2. 請勿將產品外殼拆開、改裝或撞擊，否則無保固。
 3. 請勿重壓LCD面板。
 4. 避免置於灰塵、溼氣、雨水和震動處造成不可預期短路損壞危險。
 5. 量測轉速時請保持安全距離，勿碰觸螺旋槳而發生危險。

Instructions 使用說明

1. Connection of battery balancing plug:

一、連接器使用方式：

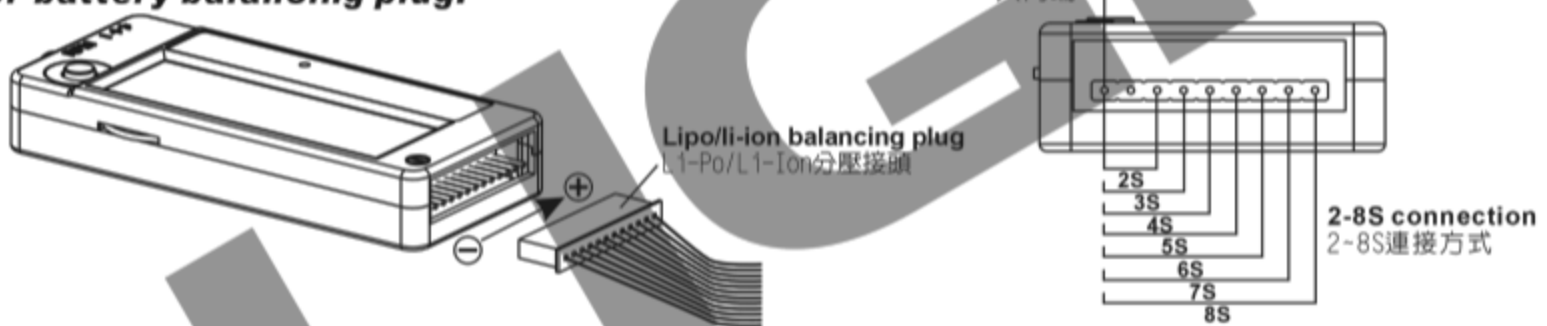

2. Mode Selection: The multi-function tester not only can measure the individual cell's voltage, it can also provide servo diagnostic as well as propeller tachometer function. When the balancing plug of a 2-8S battery pack is plugged into the battery input port, the LCD will display boot up screen. Then it enters the voltmeter function automatically. To select the servo diagnostic or tachometer function, press and hold the Mode button for approximately 2 seconds. The function cycles through as follow:

二、功能選擇：多功能電壓表除了可以量測CELL電壓外，另外還提供伺服機測試器與螺旋槳轉速器的功能，當分壓接頭插槽接入2-8S電池時，會先顯示開機畫面，接著進入電壓表功能，若欲切換至其它功能時，持續按壓功能鍵約2秒後放開，即可切換至其它功能，各功能切換順序如下圖：

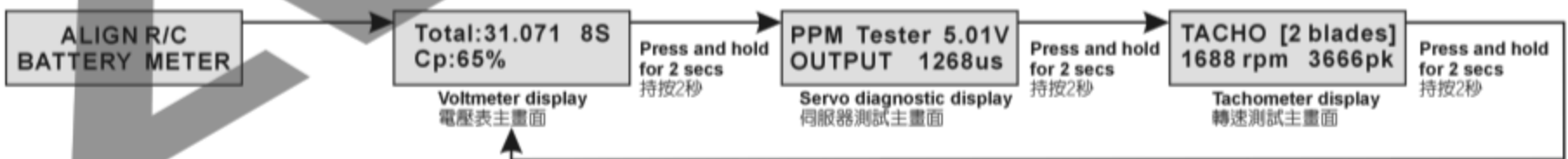

3. Voltmeter Mode:

- Within voltmeter mode, LCD first displays the battery pack's total voltage, cell count, and % of remaining capacity.
- Then with every quick press of the mode button, it will display the next two succeeding cells voltages. After the last cell voltage is displayed, the LCD will show the cell with highest and lowest voltage, along with the difference (Δv , or delta) between these two cells.
- To display voltage of 4 cells instead of 2 in a single page, quickly press the mode button twice within 1 second while in voltage mode.

三、電壓表：

- 在電壓表功能下(以8S的電池為例)：LCD顯示的內容為總電壓，電池串聯數，剩餘容量百分比。
- 接著每按下功能鍵一次則可依序顯示每一CELL的電壓值，每頁顯示2筆電壓，再按一次功能鍵則顯示最高CELL電壓、最低CELL電壓與電壓差值，再按一次即回到電壓畫面，依序循環。
- 若要LCD一次顯示4筆壓值，只要在電壓表功能的任一畫面下，連續按功能鍵2次(1秒內)，即可交替切換一頁顯示4筆或2筆電壓值。

Product Specification 產品規格

1. Voltage measurement range: 2-8S Lipo/Li-ion.
 2. Voltage display resolution: 0.001V
 3. PPM manual signal output 2270us-770us
 4. PPM automatic signal output: 1520us \pm (120-630us)
 5. Number of propeller measurable: 2 to 7
 6. Propeller rotating range: 1-60000RPM, measurement distance: 5-15cm
 7. BEC input voltage range: 4-7v
 8. Battery input terminal spec: 2.5mm pitch pins, compatible with Align compatible balancing plugs.
1. 電池組電壓量測範圍：2-8S Lipo/Li-Ion
 2. 電壓解析度：0.001V
 3. PPM手動輸出訊號：2270us-770us
 4. PPM自動輸出訊號：1520us \pm (120-630us)
 5. 量測螺旋槳數：2-7槳
 6. 轉速量測範圍：1-60000RPM，量測距離5-15cm。
 7. BEC輸入電壓範圍：4-7V
 8. 排針規格：Pitch 2.5mm，適用與Align規格相同之分壓接頭。

Parts Diagram 各部名稱

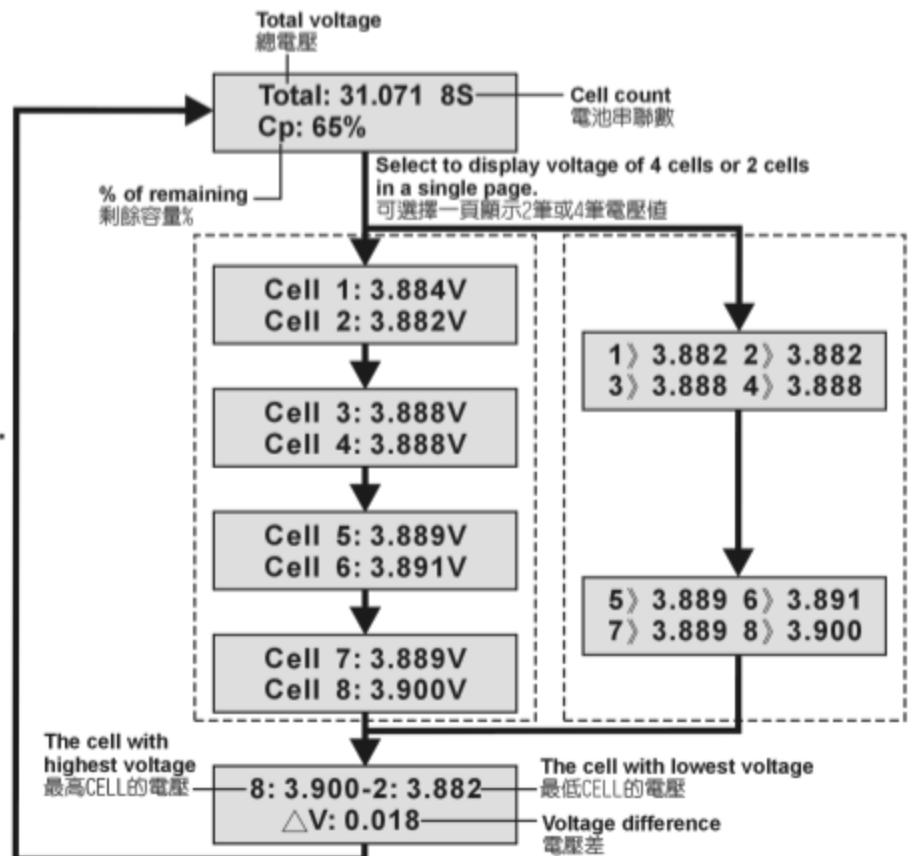
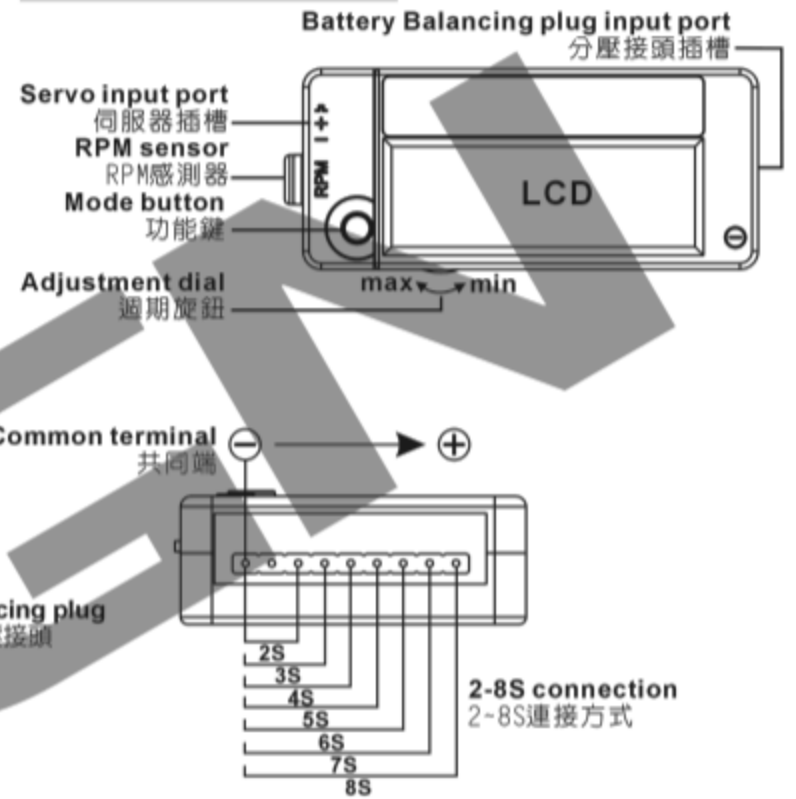

4. Servo Diagnostic Mode:

- Plug in a 2-8S lipo pack into the battery input port, and connect the servo to be tested into the servo input port. The servo can be controlled with the adjustment dial under any modes.
- Press and hold the Mode button for approximately 2 seconds to enter the servo diagnostic mode. The LCD will display PPM Tester with voltage supplied to the servo, along with the signal OUTPUT to the servo. (shown in picture below).
- Press the Mode button once to set the PPM signal to auto. The servo tester will use 1520us as center and automatically output cycling signal to move the servo arm back and forth. The adjustment dial can be used to increase or decrease amount of travel.
- Quickly pressing the Mode button twice in a second will switch the PPM tester to INPUT. This is used to detect PPM signal output of the receiver. Simply connect a receiver to the servo input port, LCD will display the receiver's output signal and voltage. Quickly pressing the Mode button twice in a second will return to servo diagnostic mode again.
- If a signal wire of an ESC is connected to the servo input port, the adjustment dial can be used to simulate throttle signal from receiver to control the motor's RPM. (Note: If the ESC connected has build in BEC, no battery will be needed on the battery balancing plug input port.)

四、伺服器測試功能:

- 先由分壓接頭插槽接上2-8S電池以提供伺服器與電壓表工作電源(只須2S電源即可正常運作),將伺服器依標示之極性插入伺服器插槽,在任何畫面下,皆可透過週期旋鈕驅動伺服器。
- 持按功能鍵2秒切換至伺服器測試主畫面(如下圖),LCD右上方顯示的電壓值為提供給伺服器的電源5伏特;調整週期旋鈕改變控制訊號的週期,伺服器會隨著週期的改變而轉動(註:伺服器中立點的訊號一般皆設定在1520 μ s)。
- 按功能鍵一次,週期訊號可設為自動模式(AUTO),測試器會以中立點1520 μ s自動送出週期訊號,使伺服器作來回擺動,擺動角度的大小可由週期旋鈕控制。
- 連續按功能鍵2次(1秒內),可切換至PPM訊號偵測模式(INPUT),用以偵測接收機送出的PPM訊號,LCD右上角顯示接收機電壓。連續再按功能鍵2次(1秒內)可再回到伺服器測試功能。
- 若將電子調速器(ESC)連接至伺服器插槽,即可透過週期旋鈕來控制馬達的轉速。(註:連接帶有BEC輸出的ESC,即不需從分壓接頭插槽提供電源)。

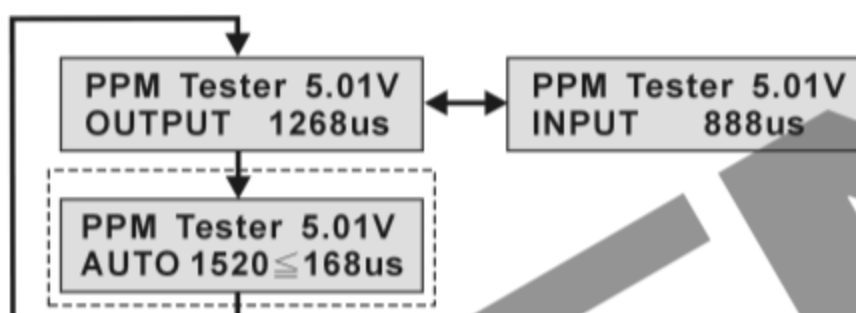
**5. Tachometer Mode:**

- Plug in a 2S lipo pack into the battery input port, press and hold the Mode button for approximately 2 seconds to enter the servo diagnostic mode, and again to enter the propeller tachometer mode.
- Press the mode button once to cycle to the next number of propeller count.
- Point the RPM sensor at the spinning propeller about 5-15cm away, the RPM will be displayed on the LCD. The "pk" number is the peak RPM attained since power up.

NOTE: Household fluorescent lights will cause interference to readings and thus such environment should be avoided.
For environment with weak lights, the measurement distance should be reduced.

五、轉速量測功能:

- 先於分壓接頭插槽接上2S電池以提供電壓表工作電源,持按功能鍵切換畫面至轉速計模式,每按功能鍵一次可設定螺旋槳的槳數,設定後將電壓表RPM Sensor對準螺旋槳,於距離5-15cm範圍內量測,畫面會即時顯示轉速與記憶最高轉速(PK值)。

※註:量測轉速時勿在日光燈下進行,以免受到日光燈頻率干擾;光線的強弱會影響偵測的距離,光線較弱的環境量測距離必須縮短。

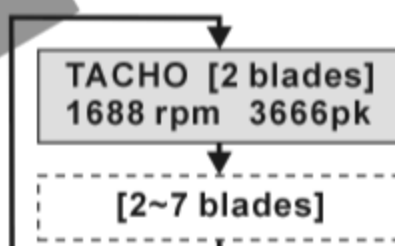

- This device also allows the use of servo diagnostic mode to control the throttle, while at the same time measure the propeller RPM with the tachometer mode. First, turn the adjustment dial counter-clockwise all the way to avoid sudden power up of the motor. Then plug in a ESC which has BEC build in to servo input port. The voltmeter will automatically enter the servo diagnostic mode after power up. Press and hold the mode button 2 seconds to enter the tachometer mode. Select the number of propellers. Then turn the adjustment dial to start up the motor.

- 以電壓表同時控制ESC與量測轉速:先將週期旋鈕逆時針調整至盡頭,避免接上ESC時進入設定模式或啟動防暴衝警示,接著將帶有BEC輸出的ESC接上伺服器插槽(不須由分壓接頭插槽提供電源),此時經開機畫面後會直接進入伺服器測試畫面,持按功能鍵2秒進入轉速計模式,設定好螺旋槳槳數後,順時針旋轉週期旋鈕即可啟動馬達,並量測轉速。

