

# Hummingbird

*Elite Series*

## Instruction Manual



**Hummingbird CP**



**Hummingbird FP**

### **SPECIFICATIONS**

Engineered for ultimate performance. Light weight, durable, powerful design featuring CNC machined anodized aluminum heat sink chassis plate, fiber reinforced composite structures, solid axle head design. CP features bell/hiller mixing.

MOTOR SIZE:	CP 370	FP 370
MAIN ROTOR DIAMETER:	520mm	533mm
LENGTH:	485mm	485mm
WEIGHT:	300-350g	300-350g

# Century Helicopter Products

Designed and Developed in USA

Copyright April 2004. All rights reserved.

### Introduction

Congratulations on the purchase of Century Helicopter Product's new Hummingbird Elite series helicopter. The Hummingbird Elite is not only ideal for beginners new to the hobby, but also for the intermediate to expert pilot looking for the ultimate in micro electric helicopter performance. A simple 4 channel "airplane" radio is all that is necessary to successfully fly the FP (Fixed Pitch) version. The CP (Collective Pitch) version requires a 6+ channel computer radio that supports 120 degree eCCPM operation. Please check with your favorite retailer or manufacturer to verify compatibility of your radio system of choice.

#### REQUIRED ITEMS

- Items needed to fly the Hummingbird
- 1x Radio (4 channels FP, 6 channels CP)
- 1x Receiver (4 channels FP, 6 channels CP)
- 2x Micro servos (FP)
- 3x Micro servos (CP)
- 1x Century micro gyro
- 1x Hummingboard mixer/speed control
- 1x Battery (8.4V or 9.6V)
- 1x Wall charger (NiMH type)
- (CP= Collective Pitch) (FP=Fixed Pitch)

### Warning

**This radio controlled model is not a toy! It is a precision machine requiring proper assembly and setup to avoid accidents. It is the responsibility of the owner to operate this product in a safe manner as it can inflict serious injury.**

**The helicopter is made pre-assembled and will require inspection for construction before your first flight.**

**As the manufacturer, we assume no liability for the use of this product.**

### Sections



The introduction



Collective and fixed pitch



Collective pitch only



Fixed pitch only

#### RULES OF R/C

-Always turn your transmitter on before powering the model.

-Always turn off the model by disconnecting the helicopter battery prior to turning off the transmitter.

-Always start your helicopter with the throttle in the lowest position.

-Always perform a pre-flight inspection for safe operation.

These rules will help prevent unsafe operation.

### Table of Contents

- Table of Contents & Introduction ..... 2
- Required Items and Building Guide for Assembly ..... 2
- Getting started ..... 3
- Installation and diagnostics for electronics ..... 4-6
- Hummingbird CP Pitch Setup ..... 7
- Radio Installation Battery Mounting and Motor break in ..... 8
- Blade Tracking, Questions and answers Section ..... 9
- Your first Flight ..... 10
- Replacement Parts (diagram) ..... 11
- Replacement Parts and Options ..... 12

## CHECKING OVER THE MODEL

Before beginning, check the kit contents as shown. This is a good time to check the "items needed to fly the Hummingbird" section on page 2 and make sure everything necessary is on hand for assembly.



### EXTRAS

Both the CP and FP models are packaged with an extra tail rotor, antenna tube, tie wraps, small allen key, sticky tape and a pitch setup tool.



## INITIAL MECHANICAL ADJUSTMENTS

The Hummingbird Elite series flybar and main blades must be set properly after removing from the package.

1. Slide the flybar until it is centered in the rotor head having equal length on each side.
2. Tighten the two set screws in the flybar control arms to secure the flybar. Flybar paddles must be parallel to each other and the ground when the swashplate is level. Make sure the bolt head in each paddle faces upwards.
3. Adjust the blade tension on the main rotor grips to be equal using the supplied allen key. The tightness should be snug but should also allow the blades to move. Setting the blades too tight may contribute to vibration.
4. Remove the canopy and set aside. You will not need the canopy until the end of the setup process.

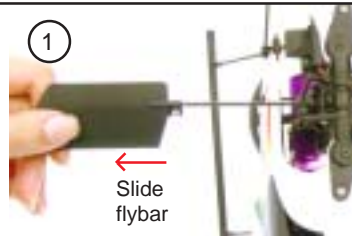

## USING ADHESIVES TO SECURE THE MODEL

Check over the landing gear area of the helicopter. Secure any loose connections using the adhesive of your choice. Using CA (cyanoacrylate) glue is very effective but difficult to debond for maintainance. Household white glue, although not as strong, works well and is easier to dissassemble later.

The canopy mounting posts should be glued to their mounting brackets to ensure a snug canopy fit.

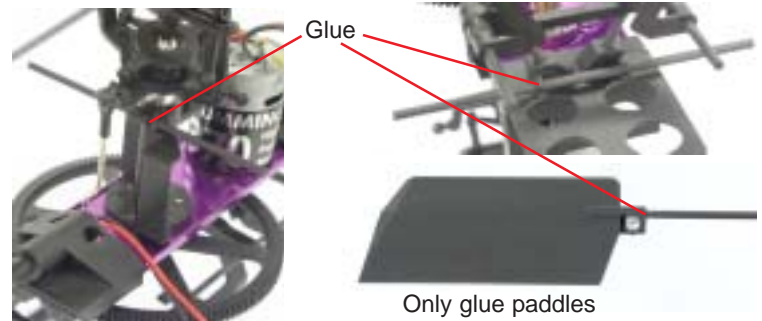

## CHARGING THE BATTERY

Before operating the Hummingbird the battery must be charged. The "Bird Seed" is the recommended battery for the Hummingbird Elite.

The charger supplied will plug in to any standard electrical wall outlet in your home. The charge time is approximately 90 minutes. Frequently check the battery temperature. The battery should be warm but not HOT when fully charged.

**Do not leave charging battery unattended. Do not overcharge. The battery is NiMH and comes partially charged. Do not completely drain a NiMH battery.**

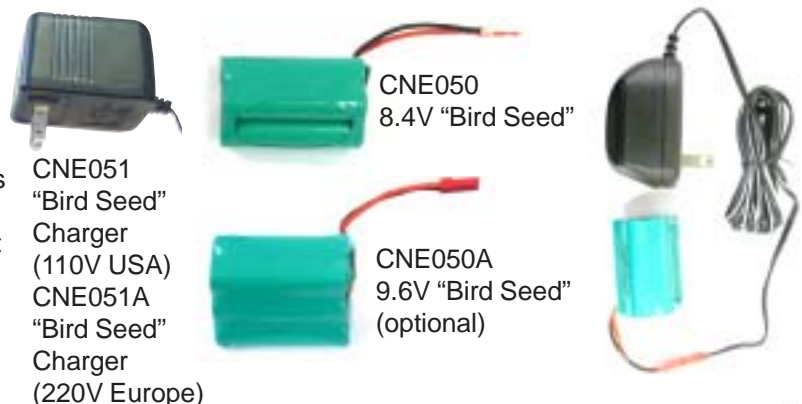

## TESTING AND PREPARATION OF RADIO EQUIPMENT

### PLEASE DON'T SKIP THIS SECTION

Before modifying or installing any radio gear, please take a few minutes to test everything as shown. Time spent becoming familiar with the equipment and testing all the components can prevent difficulty.

1. Install the crystals into the transmitter and receiver. Be certain that the channel frequency matches.



2. Note that all electronics plug into the receiver with the wires as pictured (orange wire faces receiver label). Follow the diagram for each electronic connection. Once the electronics system is connected and the transmitter is turned on, follow this step-by-step process to check your equipment.

### IMPORTANT:



All connections shown in this manual work for Futaba, Hitec & Century radio systems. If you have any other radio system please consult your radio instructions for channel numbering. (some equipment may differ in appearance.)

### STEP-BY-STEP COMPONENT TEST

1. Turn on the transmitter - Does the green LED turn on?
2. Plug the "Bird Seed" battery into your mixer board and wait for the flashing LEDs on the mixer board and the gyro to stop flashing.
3. Move the right hand stick on the transmitter left to right - does the aileron servo move?
4. Move the right hand stick forward and back - does the elevator servo move?

### Throttle Connection

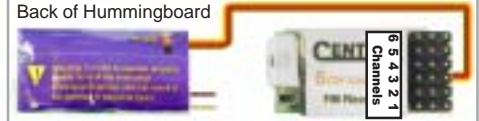

### Servo Connections

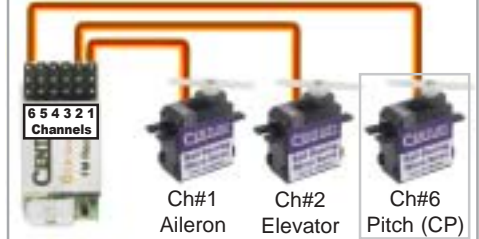

### Rudder & Gyro Connections



The gyro helps the helicopter maintain rudder heading. Without the gyro the helicopter might spin out of control.

### Motor Connections



The mixer speed controller controls the amount of power transferred to the main and tail motors in proportion.

## ELECTRONIC CONNECTION OVERVIEW

This diagram represents the overall connections for wiring the Hummingbird Elite correctly. This diagram includes the separate connections pictured above.

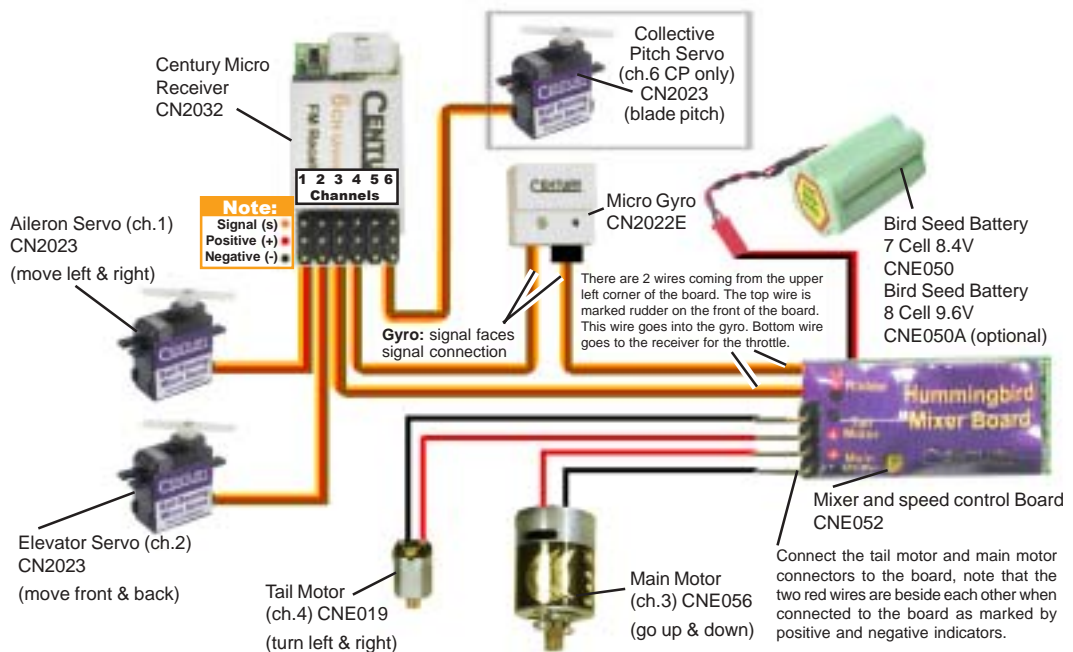

### IMPORTANT:



If you have the FP and Century Lightning 4 channel radio please refer to the wiring diagram provided with the radio system.

## MODIFYING THE SERVOS FOR INSTALLATION

1. A long half arm may have to be created by cutting a full or cross arm.

2. After testing the radio equipment the servos will be in their center position. Remove the servo retaining screw and servo wheel. Replace the wheel with one of the long half arms. See section 3 for the final positions for your version.

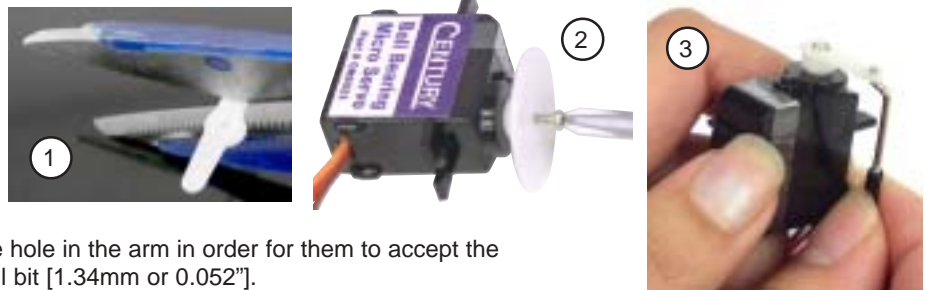

3. Some servo arms require widening the hole in the arm in order for them to accept the Hummingbird's pushrods using a #55 drill bit [1.34mm or 0.052"].

## SECTION 2A

# MODIFICATION AND DIAGNOSTICS OF THE ELECTRONIC COMPONENTS (CONTINUED)

### MODIFYING THE SERVOS FOR INSTALLATION

- 4 & 5. Trim both servo mounting flanges from each servo.
6. Cut the protruding portions from the bottom of the servo case as pictured. This will allow the best fit in the model. Note that the cut is made on the far end from the servo lead.
7. After modifying the servo it should appear as pictured.
8. Before entering section 3 you will need to remove the pushrods from the swashplate of the helicopter.

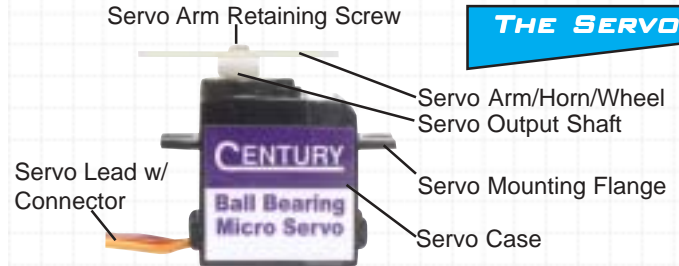

## SECTION 3

# SERVO AND PUSHROD SETUP AND INSTALLATION FOR THE FP

### MOUNTING YOUR SERVOS (FP)

1. Insert the pushrod into the hole on the servo arm farthest from the output (10-12mm from center).
2. Place servo tape on the mounting surface before mounting the servo.
3. Note that the elevator servo is mounted slightly forward (3mm or so). This will ensure that the arm can move freely.



4. Once the mounting position of the servo is determined carefully mount the servo to the mast tower. If the servo has a label on the same side that will mount with double sided tape, peel off the label and clean the surface using rubbing alcohol.

5. After mounting the servo place the plastic ball link on the corresponding control ball on the swashplate. Only use the large opening on the ball link.

6. There are only 2 servos needed on the FP. When mounted they should appear as pictured.

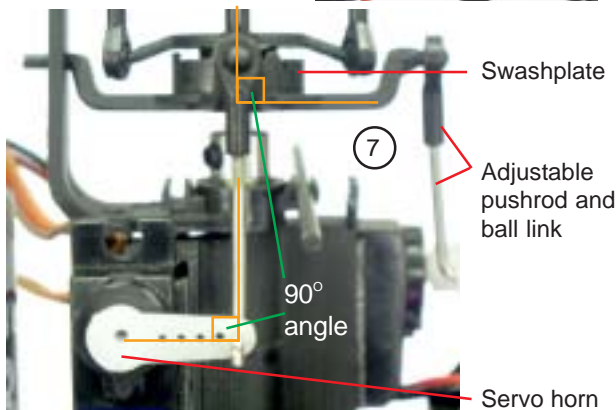

### BALL LINKS

The correct side of the ball link to mount has a larger opening than the other side and also has a lip in the plastic around the opening.



**MOUNTING YOUR SERVOS (CP) USE SECTION 4 FOR EXACT MEASUREMENTS**

1. Insert the pushrod into the hole on the servo arm farthest from the output (10-12mm from center).

2. Place servo tape on the mounting surface before mounting the servo.

3. Note that the elevator servo is mounted slightly forward (3mm or so). This will ensure that the arm can move freely.

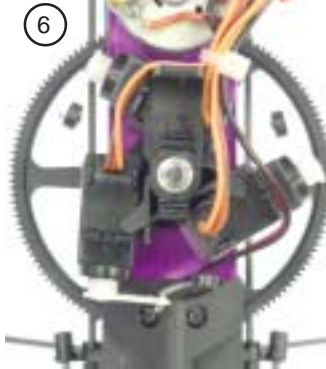
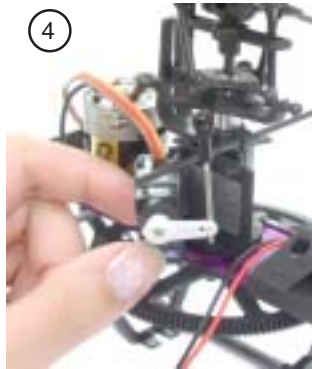

4. If the servo has a label on the same side that will mount with servo tape, peel off the label and clean the surface using rubbing alcohol. Once the mounting position of the servo is determined carefully mount the servo to the mast tower.

5. After mounting the servo. Place the plastic ball link on the corresponding control ball on the swashplate. Only use the large end of the tapered opening on the ball link.

6. There are 3 servos needed on the CP. When mounted they should appear as pictured.

7. Turn the radio on with all sticks and trims centered. Verify also that paddles, swashplate & servo horns are parallel to each other and also 90 degrees to the main shaft when all sticks are centered. Adjust the lengths of the pushrods by twisting the ball links clockwise to shorten. Twist counter-clockwise to increase the rod length.

8.) The Hummingbird Elite Collective Pitch helicopter uses the eCCPM control system. This system will require a computer helicopter radio that supports 120 degree eCCPM. Refer to Page 7 for detailed instructions on how to use eCCPM.

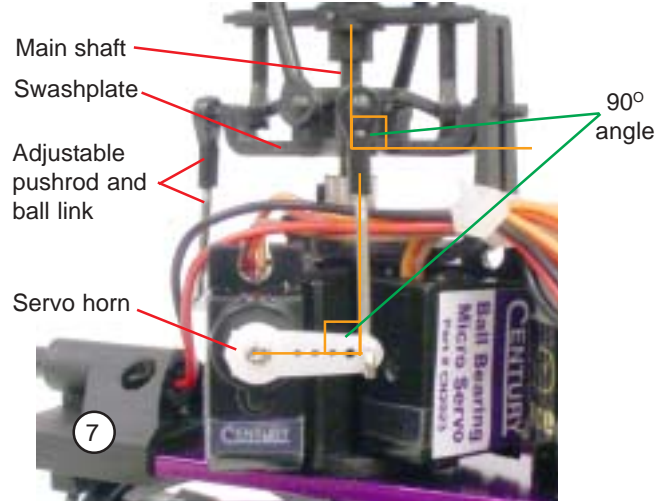

**Top View**

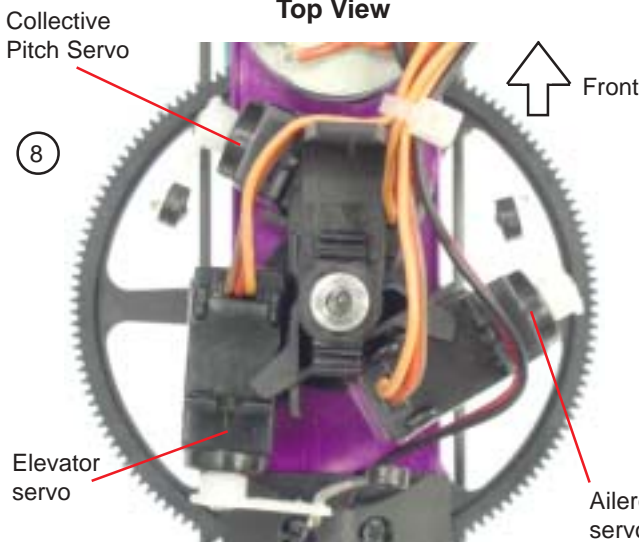

**IMPORTANT:** Refer to Page 7 for detailed instructions on how to use the eCCPM control system.

**BALL LINKS**

The correct side of the ball link to mount has a larger opening than the other side and also has a lip in the plastic around the opening.



**Expert Tips:**

To make the setup go easier on transmitters with 5 or more programmable points on the pitch curve, assuming that the 5 points correspond to low stick, point 1, point 2, point 3 and high stick. Set points 1,2,3 to 50% which will create a flat pitch curve in the center that will allow you to consistently find 50% pitch near mid stick. After servo direction and centering is completed, return points 1 & 3 back to their default values.

For highly aerobatic flying, when the rotor head speed is at 1500rpm or above, bond the flybar paddles in place using cyanoacrylate glue to the flybar.

**Radio Setup Procedure**

1. It is best to choose a new model memory (if available) and use the Reset feature to remove any previous settings or mixes. Remember this usually also returns the radio configuration to single servo.
2. Locate and activate the swashplate mixing for 120° ccpm (most manufacturers set single servo by default).
3. Return both the aileron and elevator trims and subtrims to neutral along with any hover pitch knobs to neutral.

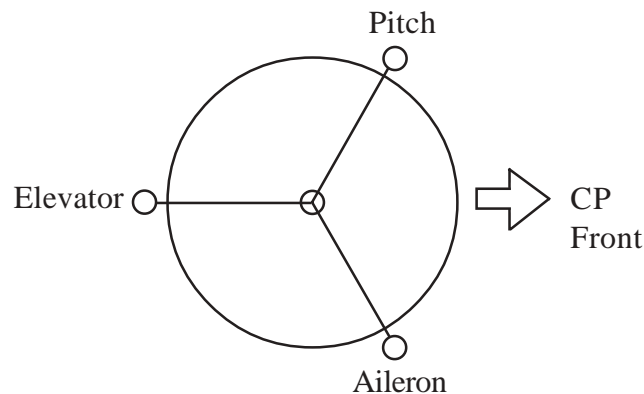
**CP setup:**

4. Power on the transmitter and the helicopter without the main or tail motors connected. Center collective stick to 50% and find the correct servo arm that is closest to 90° degrees (slightly up or down is ok).
5. Watch as the collective stick is moved that all three servo arms move in the same direction. Any servo that is moving in the wrong direction should be corrected using the servo reverse function for that channel. Continue until all three servos work together to move the swashplate in the same direction.
6. Watch as the collective stick is raised that the swashplate moves upwards. If it moves downwards, go to the ccpm swashplate menu and change the default setting to be opposite, for example, if Pitch is set to +60 then change to -60 and retest.
7. While looking from the back of the helicopter, check that when the elevator stick is moved forward that the swashplate tips forward and when the aileron stick is moved left the swashplate tips left. If the swashplate moves in the wrong direction, change the direction from the same ccpm swashplate menu. Change from the default value of +60 to -60 and retest.
8. Now that the servos are moving in the correct directions, the servo horn must be trimmed using the internal subtrim feature to position the arm be 90° degrees to its pushrod (and to the length of the servo), use the subtrim to achieve this angle, be as precise as possible.
9. Carefully remove the three pushrods from the swashplate and verify the length is 25mm from the "z" bend to the center of the ball link. Remove each servo horn one at a time and drill the last hole (photo) using a #55 drill bit [1.34mm or 0.052"] that located the pushrod at 11-12mm from the center of the servo arm pivot point.
10. Now that the basic radio setup procedure is completed, return to your pitch curve function and restore points 1 & 3 to their default values, usually 25% and 75%. Move the collective stick from low to high and watch the swashplate, if the swashplate bends at the low or high position, reduce the pitch value in the ccpm menu, for example if the value is -60 try -55 and repeat the test. Continue until the swashplate moves to the limits but does not bend.
11. Move the cyclic (aileron and elevator) sticks to the full horizontal and diagonal positions and see if the swashplate is binding against the main shaft. If it does, return to the ccpm menu and reduce the value for the servo that is binding. While holding the cyclic stick in the corner, slowly rotate the rotor head and again watch the swashplate for binding.

## INSTALLING ELECTRONICS TO YOUR HUMMINGBIRD ELITE

The electronics used to operate the Hummingbird Elite helicopter install with servo tape. This will securely mount the electronic components to the frame of the helicopter for proper operation. Be sure that the diagram on page 4 reflects the wiring connections that you make to the mounted model. (note: the below photos are an example layout)

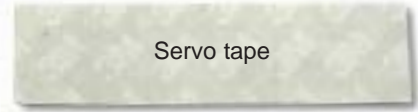

Servo tape

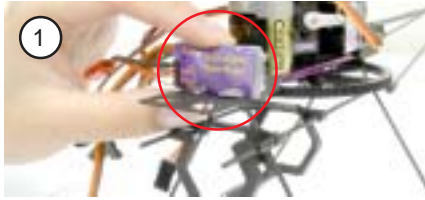

1. Mount the mixer board.



2. Mount the gyro (mount the gyro with the word "Century" oriented as pictured).

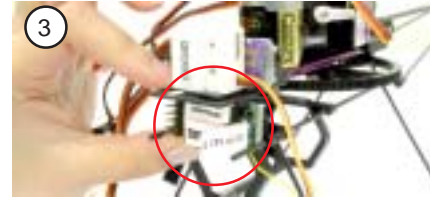

3. Mount the receiver.



4. Plug in channel 1 for aileron servo.



5. Plug in channel 2 for elevator servo.



6. Plug in channel 3 for throttle (mixer board).



7. Plug mixer rudder lead into gyro (signal wires must face each other).



8. Plug gyro into channel 4 for rudder.



9. For CP Hummingbird plug 3rd servo (collective pitch) into channel 6.

## ROUTING THE ANTENNA

To provide the best possible reception for the model, the Hummingbird Elite comes with a plastic tube for routing the antenna. Put a small hole in one end and pull the antenna all the way through leaving about 2 to 3 inches of slack. Wrap the antenna around the tube. After the antenna is almost completely wrapped around the plastic tube place a hole at the other end of the tube to secure the end of the antenna. The Hummingbird Elite series helicopters have brackets in the landing gear for mounting this plastic tube.

Place a hole here using a thumb tack.



Place a hole here using a thumb tack.



## MOUNTING THE BATTERY

The Hummingbird uses a NiMH battery. Both 8.4V and 9.6V Bird Seed batteries will work and fit in the provided battery brackets using a rubber band.

1. The battery slides back and forth on it's supports so you can adjust the center of gravity on the helicopter.

2. To test your results hold the helicopter by the flybar as pictured. Move the battery to have the helicopter sit level or very slightly nose heavy.



## HELPFUL HINT

### BREAKING IN THE 370 MOTOR

- Items required:
- 1x cup of water
- 2x D-cell batteries
- 1x series 3-volt D cell battery holder (example: Radio Shack part number 270-386A)
- 1x (Optional) female connector



First remove the main motor by locating and removing the two mounting screws under the main chassis. Immerse the motor in a cup of water. Connect the motor to the 3 volt battery holder Red wire to red wire black wire to black wire. (Tip – a female connector can be attached to the battery box for quick connection to the motor). Install batteries and Run motor for four minutes to a maximum of five minutes. Remove motor from water immersion and dry. Place one drop of light oil (CN2024T Tri-Flow oil) on each brass bushing for lubrication. Reinstall motor checking carefully for smooth gear mesh. (This procedure is only required to be performed once and only on a new motor).

Warning: Breaking in the motor is not "required" Manufacturer is not responsible for problems related with motor break-in.



## ADJUSTING THE BLADE TRACKING

### Tracking Adjustment

1. Tracking refers to trimming the actual pitch of the main rotor blades to be equal. On the first flight, bring the rotor head up to speed without leaving the ground and look at the side or profile of the rotor disk.
2. Only one rotor blade should be visible, if there are two distinctive blades then the tracking linkage must be changed. Observe which blade color is lower and carefully remove the ball link on that blade grip and shorten the link by one complete turn.



Both blades should track in the same line A=B.



## TROUBLESHOOTING QUESTIONS AND ANSWERS

### Q: Everything is on and connected. Why won't the rotors turn?

- A: -The throttle trim may be set too high try moving the trim to the lowest point.  
 -Your gyro may be installed incorrectly make sure the the order of wires is as shown on page 4.  
 -Your throttle channel may be reversed.

### Q: Why does the helicopter spin like a top?

- A: -It's possible that the rudder channel on your radio is reversed or your gyro is installed upside down. Please see page 8 for best mounting location.  
 -Check the connections to the receiver to make sure connections are correct. If the problem persists take a look at the direction the tail motor turns.  
 -The curved portion of the tail rotor should move forward being the "leading edge". If this is not the case please check the polarity of the motor's connection to the mixer board.

### Q: Why is there vibration?

- A: -The main blades may be out of track. Refer to the blade tracking information above.  
 -The main shaft may be bent. This can be difficult to notice when the blades are not moving. A bent main shaft can be caused in a crash or a hard blade strike.  
 -Vibration can also result from any loosely connected components such as the battery tray or the landing gear. Make sure to secure them and be sure to check the frame and flybar every time you crash or have a hard landing as they may need to be repositioned.

### Q: Why won't the helicopter come off of the ground?

- A: -Be sure that the gear mesh on the main motor moves smoothly and that the battery is fully charged. Do not fully discharge a NiMH type battery as it will lose it's capacity memory.  
 -If you don't think it's the battery it's possible that slightly damaged blades are reducing the possible lift. If there is a part of the blade broken off especially near the tip the helicopter may not lift properly.  
 -Check to make sure nothing is rubbing against the main gear possibly slowing its RPM.

### Q: Why is it so difficult to move the helicopter backwards?

- A: -The elevator servo may be installed too far to the rear. The servo may have to move forward in its mount so the servo arm will clear the rear of the frame.

### Q: Why does the helicopter operate on its own without my command inputs?

- A: -You may be getting hit with interference. RF interference can occur for many reasons. Ordinary household electronics, televisions, cell phones, microwaves, electric tools and other R/C models can add to the field of interference affecting your model. Try turning off unnessesary electronics or find an area where there are less electrical disturbances.

### Q: Why does the helicopter still move too far forward or backward even after adjusting the servo arm positions and trims?

- A: -The helicopter may not have an even center of gravity. You can slide the battery in it's mounting tray to adjust it's center of gravity.  
 -You can also combine your battery weight centering with trims and servo arm positions to get any desired combination.

During regular operation the Hummingboard will remain solid green but as the battery starts to run out and the voltage drops the helicopter will simply descend. At this time it is best to land immediately.

## BASIC HOVERING

### Hovering

when all is set, ready and checked, it's time for the initial flight.

1. Stand behind the model about 10' away.
2. Always watch the nose of the helicopter, move the rudder left and the nose will move left.
3. Start by increasing the throttle slowly until the helicopter rises 2-6 inches off the ground then set it back down.
4. Repeat this process until you become comfortable with the holding the model in the same spot for a few seconds then land it.

After some time at this you can increase the height slightly up to 1 foot (be very carefull not to fly too high) as you are practising taking off and landing. This is the most basic but required skill for the beginner to learn.

### Beyond Hovering

It cannot be stressed enough that mastering the hovering skill is crucial to becoming a good helicopter pilot. As you progress in your learning, always practise hovering until you are completely comfortable in holding the helicopter in any direction at any altitude. Perfecting hovering enables you to learn all the types and styles of helicopter flying, forward flight, loops and rolls, 3D (aerobatic flying) and anything you want to do with your helicopter as it can be set up for beginner through to expert. Lastly, have fun!!

## PRE-FLIGHT CHECKLIST

1. After turning the radio on, move each servo separately, looking for unusual or excessive movement.
2. Inspect the main and tail rotor blades for damage. Never fly damaged blades.
3. Inspect the main and tail rotor linkage for play or binding.
4. Turn the main gear in both directions to feel if a problem is developing.
5. Check the electronics connections making sure everything is correct.

## TRIM AND THROTTLE ADJUSTMENTS

**Control Movement** - All trimming of the Hummingbird should be done one click or detent of the subtrims at a time until it will rise without moving left, right, forward or backward at a location without wind. Some tail rotation is normal at lift off until it is hovering. Start by lifting the Hummingbird 3-6 inches at a time to practice lift off and landing.

All trim adjustments are to allow you to lift the helicopter straight up and can be made one click or detent at a time on the radio.

(1) **Collective & Throttle:** Slowly raise the throttle stick, the helicopter should lift off at half stick. If it tends not to lift off increase the hover pitch on the radio or increase the throttle trim. If the helicopter lifts off before mid stick decrease these settings. (collective present in CP model only.)

(2) **Rudder:** When the helicopter is ready to take off, make a correction trim first then use the rudder stick to control the Left & Right. Note, now is a good time to make a final adjustment on the gyro.

(3) **Elevator:** If at hover the helicopter tends to move forward, move the trim down, if it moves backward move the trim upwards. Use the elevator stick to control the Forward & Backward.

(4) **Roll (Aileron):** If at hover the helicopter tends to move left, move the trim right, if the helicopter moves to the right move the trim left. Move the Aileron stick to control the slide of the helicopter to the Right & Left.

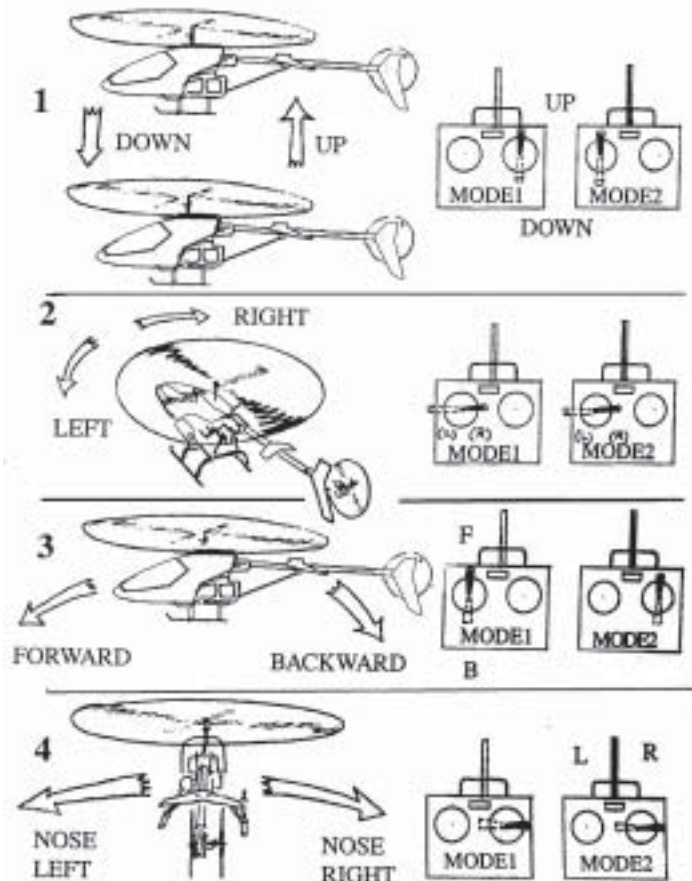



					
<b>CNE201</b> Head Axle & Dampeners	<b>CNE202</b> Blade Grips FP	<b>CNE203</b> Blade Grips CP	<b>CNE204</b> Main Blades FP	<b>CNE205</b> Head Block	<b>CNE206</b> Flybar
					
<b>CNE207</b> Flybar Paddles	<b>CNE208</b> Seesaw Parts (covers parts for CP & FP)	<b>CNE209</b> Head Link Set (covers parts for CP & FP)	<b>CNE209A</b> Swashplate Links	<b>CNE210</b> CP Mixing Levers & Links	<b>CNE211</b> Swashplate FP
					
<b>CNE212</b> Swashplate CP	<b>CNE213</b> Main Shaft Bearings	<b>CNE214</b> Mast Tower FP	<b>CNE215</b> Mast Tower CP	<b>CNE216</b> Antirotation Bracket	<b>CNE217</b> Chassis Plate
					
<b>CNE218</b> Main Gear	<b>CNE219</b> Main Shaft & Collar	<b>CNE220</b> Landing Gear Set	<b>CNE221</b> Tail Boom & Gearbox	<b>CNE222</b> Fins & Boom Supports	<b>CNE223</b> Tail Gear & Shaft
					
<b>CNE224</b> Tail Rotor Blade	<b>CNE225</b> Canopy	<b>CNE226</b> Battery Tray	<b>CNE227</b> Semi-Sym Wood Blades CP	<b>CNE021</b> Tail Shaft Bearings	<b>CNE023</b> Servo Tape Tie Wraps & Rubber Band
					
<b>CNE056A</b> Main Motor With Gear	<b>CNE019</b> Tail Motor With Gear	<b>CNE050</b> 8.4V Bird Seed Battery	<b>CNE051</b> Charger 110V (USA) <b>CNE051A</b> Charger 220V(Europe)	<b>CNE052</b> Mixer Control Board	<b>CN2022E</b> Micro Gyro

**OPTIONAL ITEMS AND ACCESSORIES**

				
<b>CNE252</b> Lightning Brushless Main Motor	<b>CNE250</b> Auto Rotation Hub & Gear	<b>CNE251</b> Machined Main Rotor Hub With Head Button	<b>CN2033</b> Hyper Charger <small>*Charges 7 cell 8.4V 'Bird Seed' in 30 minutes. *Not for use with lithium type.</small>	<b>CNE057</b> 700mAh 11.1V <b>CNE057A</b> 700mAh 7.4V <b>CNE058</b> 1400mAh 11.1V
				
<b>PHX-10</b> Castle Creations Brushless Speed Control	<b>CNE228</b> Fully Symmetrical Wood Main Blades	<b>CNE050A</b> Bird Seed 9.6V Battery	<b>CNE061</b> Main Motor Heat Sink	<b>CNE060</b> Tail Motor Heat Sink