

**DURATRAX**<sup>®</sup>

# DELPHI INDY CAR

1/10 Scale Ready-To-Run Electric Race Car

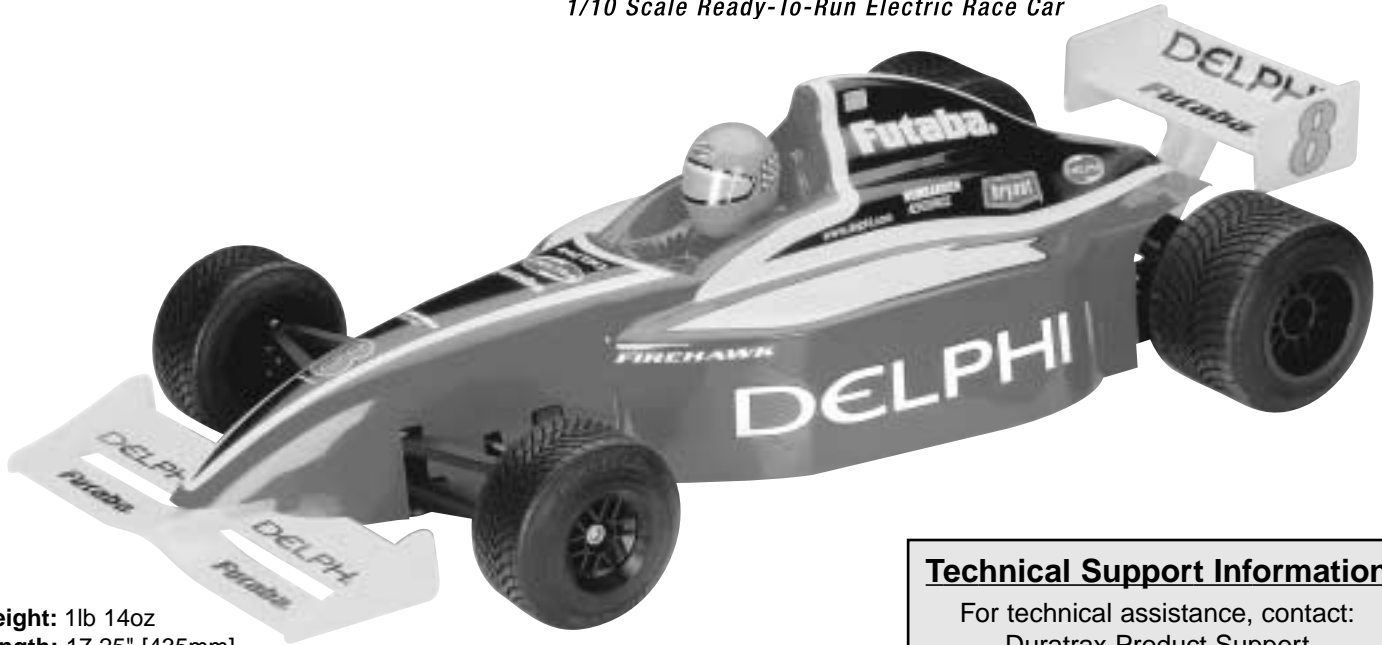

**Weight:** 1lb 14oz  
**Length:** 17.25" [435mm]  
**Width:** 8" [205mm]  
**Height:** 4.5" [115mm]  
**Wheelbase:** 10.5" [265mm]  
**Motor:** 20 Turn Photon Speed  
**Radio:** 2 channel surface frequency

## Technical Support Information

For technical assistance, contact:  
DuraTrax Product Support  
1610 Interstate Drive  
Champaign, IL 61822  
(217) 398-8970, Ext. 2  
carsupport@duratrax.com

## **ASSEMBLY AND OPERATION MANUAL**

### **Warranty**

- **DuraTrax**<sup>®</sup> will warranty this kit for 90 days after the purchase date from defects in materials or workmanship. DuraTrax will either repair or replace, at no charge, the incorrectly made part.
- Make sure you **save the receipt or invoice** you were given when you bought your model! It is your proof of purchase and we must see it before we can honor the warranty. Further, DuraTrax reserves the right to change or modify this warranty without notice.
- To return your Delphi Indy car for repairs covered under warranty you should send your vehicle to:

**Hobby Services**  
1610 Interstate Drive  
Champaign, Illinois 61822  
Attn: Service Department  
Phone: (217) 398-0007 9:00 am - 5:00 pm Central Time M-F  
E-mail: [hobbyservices@hobbico.com](mailto:hobbyservices@hobbico.com)

If the buyer is not prepared to accept the liability associated with the use of this product, the buyer is advised to return this kit immediately in new and unused condition to the place of purchase.

**READ THROUGH THIS MANUAL BEFORE STARTING CONSTRUCTION. IT CONTAINS IMPORTANT INSTRUCTIONS AND WARNINGS CONCERNING THE ASSEMBLY AND USE OF THIS MODEL.**

## TABLE OF CONTENTS

INTRODUCTION.....	2
SAFETY PRECAUTIONS .....	2
HELPFUL HINTS .....	2
STRESS TECH PARTS GUARANTEE .....	3
REPAIR SERVICE .....	3
SPECIFICATION & DESCRIPTION CHANGES .....	3
REQUIRED ITEMS FOR COMPLETION.....	3
TOOLS NEEDED FOR COMPLETION .....	3
TOOLS INCLUDED FOR MAINTENANCE .....	3
FINISHING THE RTR VERSION .....	4
ELECTRONIC SPEED CONTROL SET-UP .....	5
FINISHING THE PRE-BUILT VERSION .....	5
PREPARING THE RADIO SYSTEM.....	5
CHECKING THE RADIO SYSTEM.....	5
STEERING SERVO INSTALLATION.....	6
RECEIVER INSTALLATION .....	7
ELECTRONIC SPEED CONTROL INSTALLATION .....	7
ELECTRONIC SPEED CONTROL SET-UP .....	8
ASSEMBLY GUIDE .....	9
Front End.....	9
Main Chassis.....	10
Main Shock.....	10
Side Shocks.....	10
Motor Plate Assembly .....	11
Upper Plate.....	12
Main Shock Installation.....	12
Gear Differential.....	13
INLINE BATTERY PLACEMENT CONVERSION.....	13
MAINTENANCE TIPS .....	14
Before Each Run.....	14
After Each Run.....	14
After Every Ten Runs.....	14
TUNING GUIDE .....	15
Front Toe-In and Toe-Out.....	15
Battery Placement .....	15
Ride Height.....	15
Rear Plate Adjustment .....	15
Differential Adjustment .....	15
Side Shock Adjustment.....	15
Optional Shock Springs .....	Back Cover
Tire Tips .....	Back Cover

## INTRODUCTION

Thank you for purchasing the DuraTrax Delphi Indy car. This manual contains the instructions you need to build, operate and maintain your new electric R/C vehicle. Read over this manual thoroughly before building or operating the Delphi Indy car.

## SAFETY PRECAUTIONS

When the safety precautions are followed, the Delphi Indy car will provide years of enjoyment. Use care and good sense at all times when operating this radio controlled vehicle. Failure to use this vehicle in a safe, sensible manner can result in injury or damage to property. You and you alone must insure that the instructions are carefully followed and all safety precautions are obeyed.

- Do not operate the Delphi Indy car near people. Spectators should be behind the driver or at a safe distance away from the vehicle.
- Make sure to read the instructions with the battery and charger before charging. Do not leave the charger unattended during charging. If the battery or charger becomes hot at any time disconnect the battery from the charger immediately! Failure to do so may cause permanent damage to the charger and battery and may cause bodily harm. Do not cover the air intake holes on the charger during charging, this may cause the charger to overheat.
- Do not allow the electronic speed control (ESC) or radio equipment to come into contact with moisture. Water can cause the electronics to short out and can cause permanent damage.
- Always turn on the transmitter before turning on the electronic speed control.
- Before turning on your radio check to make sure that no one else is running on the same frequency as your Delphi Indy car.

## HELPFUL HINTS

- Avoid working over a deep pile carpet. If you drop a small part or screw, it will be difficult to find. Place a mat or towel over your work surface. This will prevent parts from rolling off and will protect the work surface.
- Avoid running the vehicle in cold weather. The plastic and metal parts can become brittle at low temperatures. In addition, grease and oil become thick, causing premature wear and poor performance.
- Test fit all parts before attaching them permanently

## STRESS-TECH PARTS GUARANTEE

We have engineered the Delphi Indy car to take the rough and tumble abuse that makes R/C vehicles fun. We are so confident of the quality and durability of the Stress-Tech plastic parts that we will replace any Stress-Tech plastic part you break during the first 12 months you own the vehicle. Just send in the part to us and we will send you a **FREE** replacement. Please see the Delphi Indy cars parts list for the items covered under the Stress-Tech guarantee.

To receive your free replacement part, please send the following to the Hobby Services address listed on the cover of this manual.

- 1. The broken part must be included.
- 2. The part number and description of the broken part.
- 3. Dated copy of your invoice or purchase receipt.
- 4. Your name, phone number and shipping address.

## REPAIR SERVICE

- Repair service is available anytime.
- After the 90 day warranty, you can still have your Delphi Indy car repaired for a small charge by the experts at DuraTrax's authorized repair facility, Hobby Services, at the address listed on the front page of this manual.
- To speed up the repair process, please follow the instructions listed below.
  - 1. Under most circumstances return the **ENTIRE** system: vehicle and radio. The exception would be sending in a Stress-Tech part. See the instructions under Stress-Tech Guarantee.
  - 2. Make sure the transmitter is turned off and all of the batteries are removed.
  - 3. Send written instructions which include: a list of all items returned, a **THOROUGH** explanation of the problem, the service needed and your phone number during the day. If you expect the repair to be covered under warranty, be sure to include a proof of date of purchase (your store receipt or purchase invoice).
  - 4. Also be sure to include your full return address.

## SPECIFICATION & DESCRIPTION CHANGES

All pictures, descriptions and specifications found in this instruction manual are subject to change without notice. DuraTrax maintains no responsibility for inadvertent errors in this manual.

## REQUIRED ITEMS FOR COMPLETION

**To operate the Delphi Indy car the following items are required:**

- DurTrax 6-cell battery pack (DTXC2030)
- DuraTrax 6-7 cell charger (DTXP4000)
- Hobby knife (HCAR0105)

**For the pre-built version of the Delphi Indy car, you will also need:**

- 2-Channel radio with one (1) standard servo (FUTJ13\*\*).  
**Note:** The electronic speed control is supplied with a Futaba connector. The receiver must be equipped to accept these plugs.
- Eight (8) "AA" batteries for the transmitter

## TOOLS NEEDED FOR COMPLETION AND MAINTENANCE

- #2 Phillips head screwdriver (Not Included)
- Needle nose pliers (Not Included)

## INCLUDED TOOLS FOR MAINTENANCE AND TUNING

- Nut driver (4-way)
- Hex wrenches

## FINISHING THE DELPHI INDY CAR RTR VERSION (DTXD12\*\*)

- ❑ 1. Remove the Delphi Indy car and Radio system from the box.
- ❑ 2. Charge the 6-cell battery (not included) using the charger (not included). **Follow the charger's instruction manual and safety precautions.**

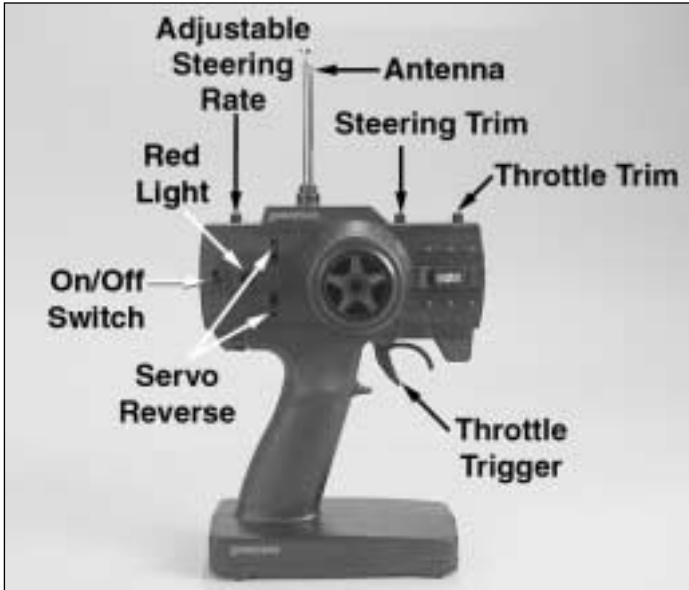

- ❑ 3. Install the transmitter antenna by screwing it into the hole on the top of the transmitter. Give the antenna a quick tug to make sure it is securely attached.



- ❑ 4. Slide open the battery door on the bottom of the transmitter. Install eight (8) "AA" batteries into the transmitter in the configuration molded into the plastic on the battery holder. Re-install the battery door.

- ❑ 5. Turn on the transmitter using the on/off switch (see step 3). The red light on the transmitter should light up. If there is no light on, turn the transmitter off and check to ensure that the batteries are making contact with the metal contacts in the battery holder and are installed correctly. Turn the transmitter on and check for the red light. If the red light appears, turn off the transmitter. If the red light blinks, the batteries are low and should be replaced.

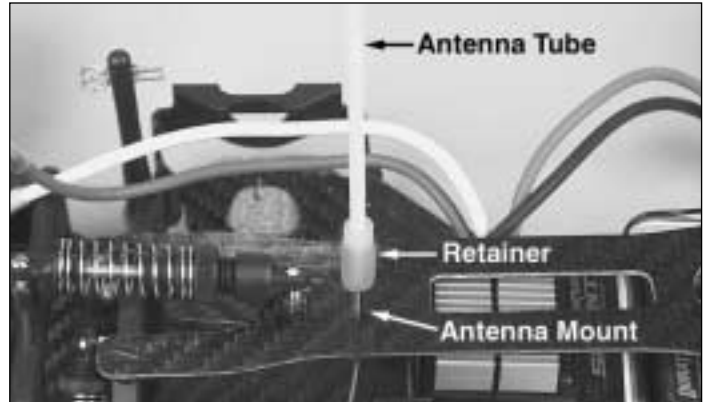

- ❑ 6. Remove the twist-tie from the receiver antenna. Route the receiver antenna up to the antenna mount on top of the upper plate. Locate the antenna tube and retainer. Thread the receiver antenna through the retainer and then through the antenna tube. Press the retainer partially onto the antenna mount then insert the antenna tube into the retainer. **NOTE:** The antenna will be longer than the antenna tube. **DO NOT CUT OR COIL THE ANTENNA WIRE.** **Tip:** Run the antenna wire through your fingers to straighten out the kinks before running through the antenna tube.

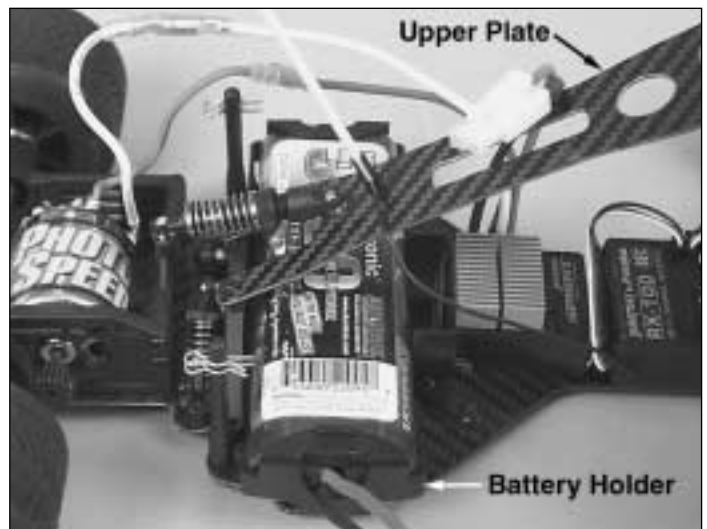
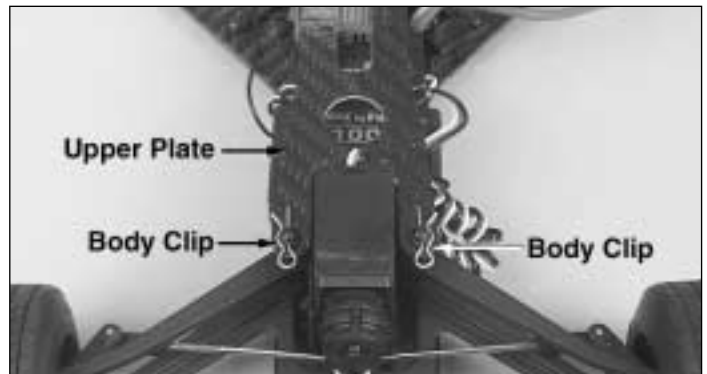

- ❑ 7. Remove the body clips from the upper plate posts and lift the upper plate away from the chassis. Install the charged 6 cell battery into the battery slot. Re-install the upper plate onto the Delphi Indy car as shown above. Re-install the body clips into the upper plate posts.



❑ 8. Decal the body as desired.

## ELECTRONIC SPEED CONTROL SET-UP

**NOTE:** The Sprint electronic speed control is pre-set at the factory. The following instructions should be followed if the pre-set needs to be changed. During normal running, the speed control should be switched “on” and

not given input from the transmitter for 3 seconds. This bypasses the set-up stage of the ESC.

- ❑ 1. Turn the transmitter on.
- ❑ 2. **Note:** The set-up portion of the Sprint ESC occurs in the first 2 seconds when the speed control is turned on. Set the throttle trim of the transmitter at neutral.
- ❑ 3. Turn the electronic speed control on. The green LED will light up for approximately 1 second.
- ❑ 4. Squeeze the throttle trigger, the red LED on the ESC will light up to indicate full forward is now being operated.
- ❑ 5. Push the throttle trigger to full reverse, the green and red LED's on the ESC will light up to indicate that full reverse is being operated.
- ❑ 6. Finally, let go of the trigger. The speed control will hold this setting until it is reset.

## FINISHING THE DELPHI INDY CAR PRE-BUILT VERSION (DTXC0020)

### PREPARING THE RADIO SYSTEM

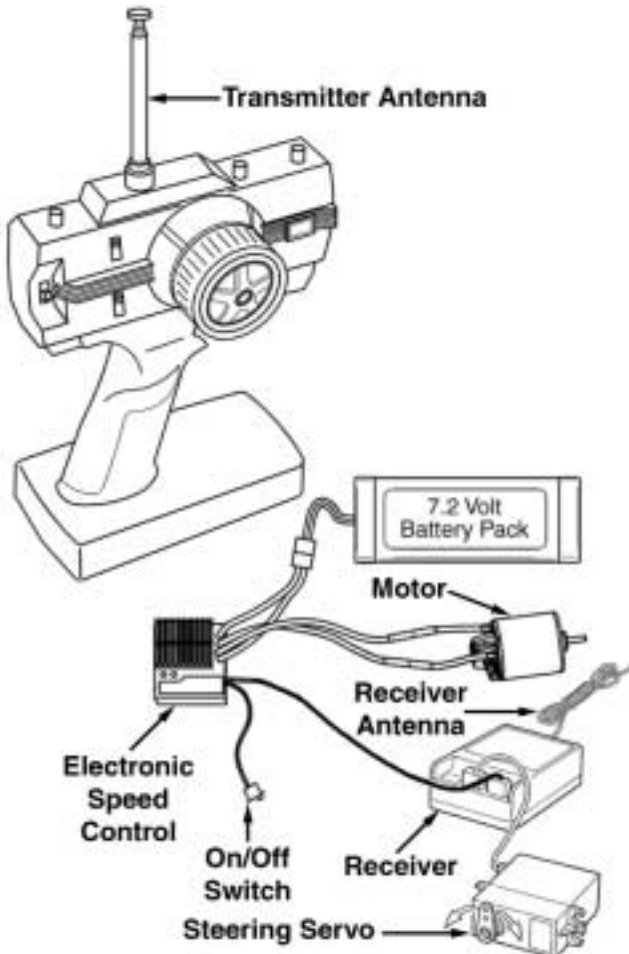

### CHECKING THE RADIO SYSTEM

Carefully read the radio manufacturer's instructions before starting assembly.

- ❑ 1. Install the “AA” batteries in the transmitter.
- ❑ 2. Install and extend the transmitter antenna.
- ❑ 3. Connect the steering servo and electronic speed control to the receiver.
- ❑ 4. Uncoil and extend the receiver antenna.
- ❑ 5. Hook up the charged 6 cell battery to the electronic speed control.
- ❑ 6. Adjust the servo trims of the transmitter to the neutral position.
- ❑ 7. Switch on the transmitter.
- ❑ 8. Switch on the electronic speed control.
- ❑ 9. Set up or tune the ESC.
- ❑ 10. Operate the steering and throttle control. Make sure the steering servo arm and motor move in proportion to the movement of the steering wheel and throttle trigger.
- ❑ 11. Switch off the ESC, then the transmitter.

# STEERING SERVO INSTALLATION

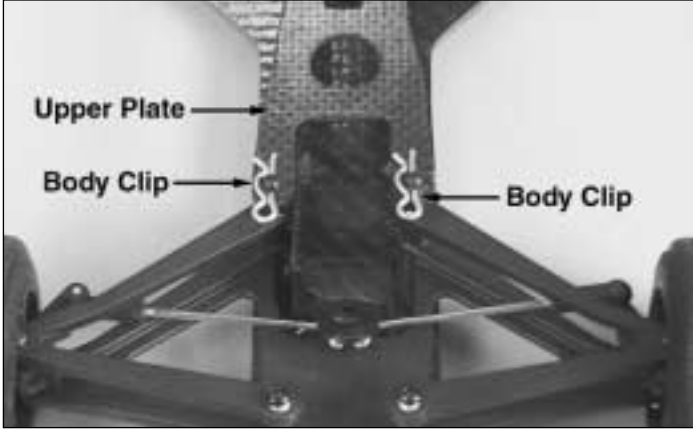

□ 1. Remove the upper plate by removing the two body clips in the front and lifting the front of the upper plate up out of the way. **Note: To completely remove the upper plate you must first detach the rear shock from the upper plate.**



□ 2. Using a pair of sharp cutters or a hobby knife remove the servo mounting tabs on both ends of the servo as shown above. Make sure the area where the mounting tabs were located is flush with the case when you are done. This will provide a good contact surface for the servo to mount.

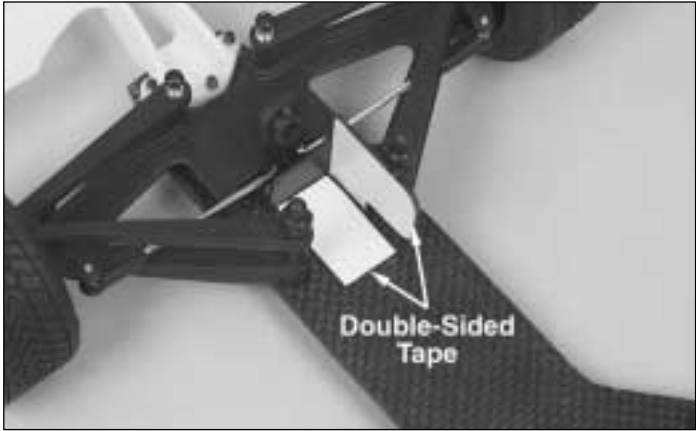

□ 3. Install a piece of included double-sided tape to the inside of the servo mount and a piece to the chassis as shown.



□ 4. Install the servo onto the chassis, securing it in place with the double-sided tape. **Note: The servo needs to be mounted so that the output shaft is in the upper position as shown.**

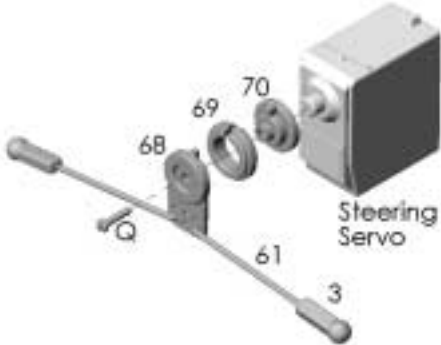
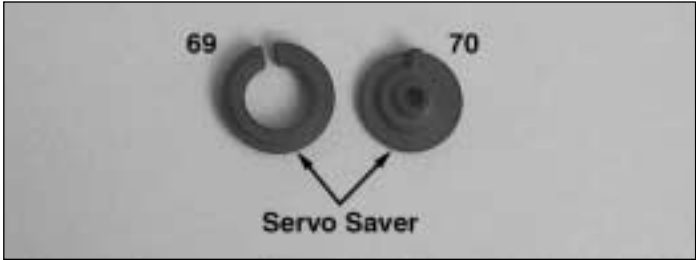

□ 5. Locate the two servo saver parts (69) and (70 FUT, AIR, HTEC, or MUL, depending on your servo brand) and install them onto the pre-mounted servo saver part (68). Install this

assembly onto the servo. **Note: Do not install the servo horn screw at this time. The transmitter and servo will need to be centered later.**

## RECEIVER INSTALLATION

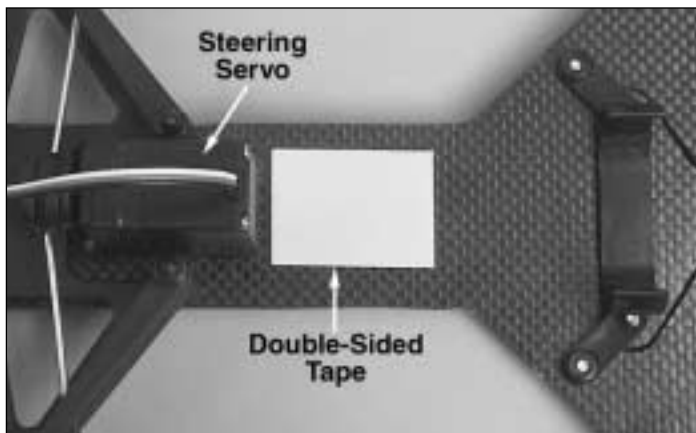

□ 1. Install a large piece of double-sided tape onto the chassis directly behind the steering servo. Install the receiver onto the double-sided tape. Install the receiver in the direction shown in the following step. **Note: Do not worry about the receiver's antenna wire at this point. It will be installed once the battery has been installed.**

## ELECTRONIC SPEED CONTROL INSTALLATION

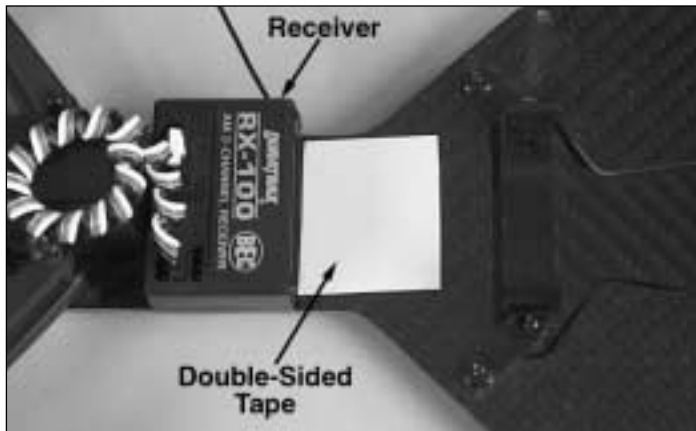

□ 1. Install a large piece of double-sided tape on the chassis directly behind the receiver for the ESC to mount to. Mount the ESC onto the double-sided tape. Connect the motor wires to the motor (white to white, blue to blue).

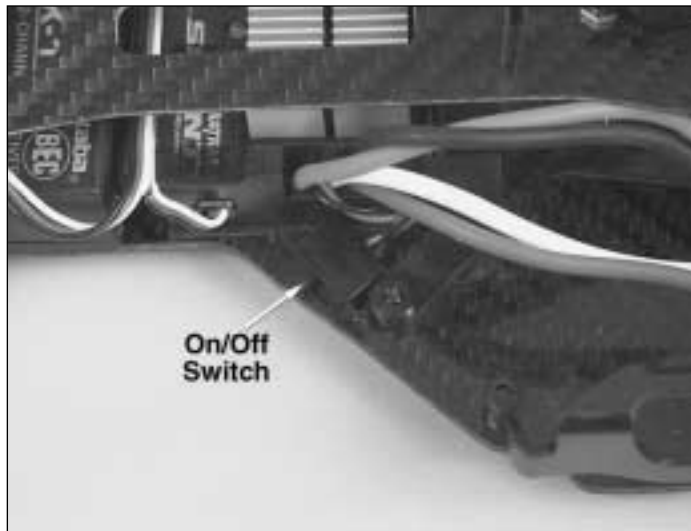

□ 2. Secure the ESC's on/off switch to the chassis using a small piece of double-sided tape. Make sure that you place the switch in a position where it will not get turned "off" during running.

□ 3. Install the charged 6-cell battery into the battery slot. Route the battery wire through the center of the side mount.

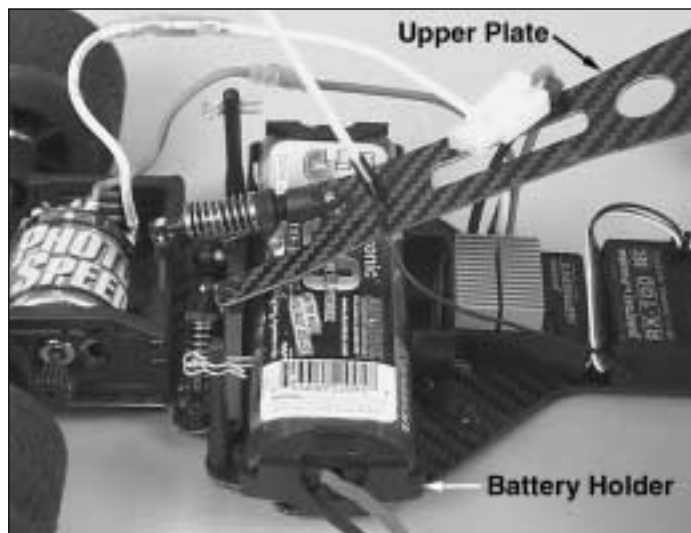

□ 4. Re-install the upper plate onto the chassis of the Delphi Indy car. Secure the front of the upper plate to the chassis using the previously removed body clips. **Note: If you completely removed the upper plate from the chassis you must re-install the rear shock.**

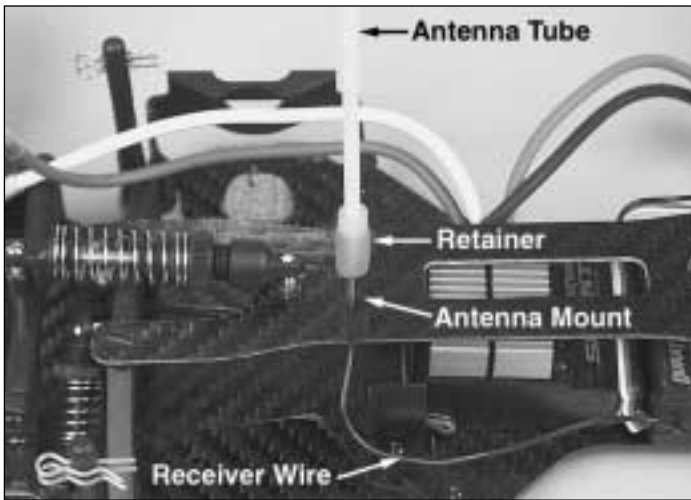

## ELECTRONIC SPEED CONTROL SET-UP

**NOTE:** The Sprint electronic speed control is pre-set at the factory. The following instructions should be followed if the pre-set needs to be changed. During normal running, the speed control should be switched “on” and not given input from the transmitter for 3 seconds. This bypasses the set-up stage of the ESC.

□ 5. Remove the twist-tie from the receiver antenna. Route the receiver antenna up to the antenna mount on top of the upper plate. Locate the antenna tube and retainer. Thread the receiver antenna through the retainer and then through the antenna tube. Press the retainer partially onto the antenna mount then insert the antenna tube into the retainer. **NOTE:** The antenna will be longer than the antenna tube. **DO NOT CUT OR COIL THE ANTENNA WIRE.** **Tip:** Run the antenna wire through your fingers to straighten out the kinks before running through the antenna tube.

□ 6. Plug the ESC and steering servo leads into the appropriate slots in the receiver. **Note: Refer to the transmitter's instruction manual to determine the proper slot for each.**

□ 7. Remove the steering servo saver from the steering servo. Connect the battery to the ESC. Center the trims on the transmitter then turn it “on.” Then turn the ESC “on.” Place the servo saver back onto the servo so that the wheels are both facing as straight forward as possible. Secure the servo saver onto the servo using the servo horn screw included with the servo. **Note: The steering may need to be fine tuned using the trim adjustment on the transmitter.**



□ 8. Decal the body as desired.

□ 1. Turn the transmitter on.

□ 2. **Note: The set-up portion of the Sprint ESC occurs in the first 2 seconds when the speed control is turned on.** Set the throttle trim of the transmitter at neutral.

□ 3. Turn the electronic speed control on. The green LED will light up for approximately 1 second.

□ 4. Squeeze the throttle trigger, the red LED on the ESC will light up to indicate full forward is now being operated.

□ 5. Push the throttle trigger to full reverse, the green and red LED's on the ESC will light up to indicate that full reverse is being operated.

□ 6. Finally, let go of the trigger. The speed control will hold this setting until it is reset.



## ASSEMBLY GUIDE

The following information has been provided to help maintain and tune the Delphi Indy Car.

### FRONT WING

Secure the front wing (1) to the main chassis (38) using (3) 3x10mm flat head self-tapping screws (B).

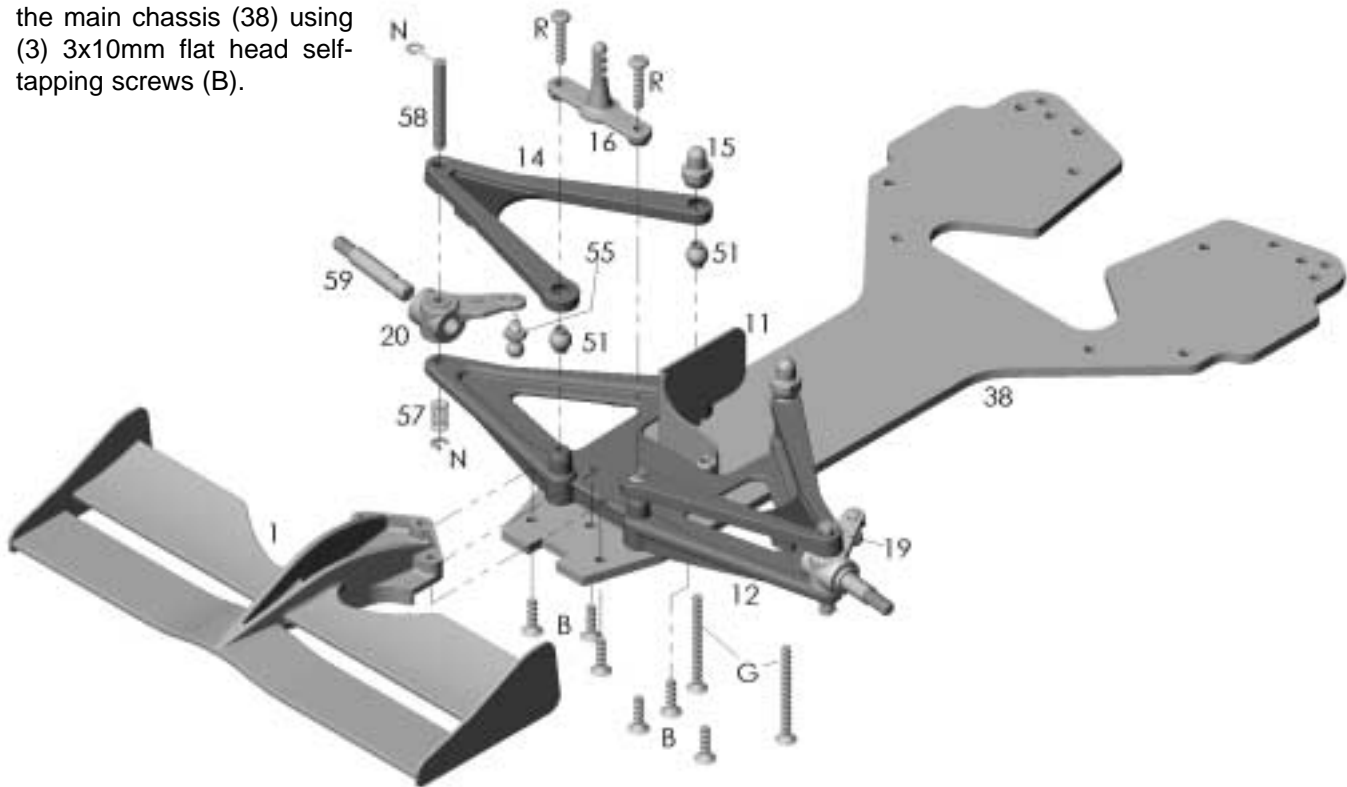

### FRONT END

1. Attach the lower front arm (12) to the main chassis (38) using (2) 3x10mm flat head self-tapping screws (B) and (2) 3x30 flat head self-tapping screws (G).
2. Install the (4) 6mm pivot balls (51) into the upper suspension arms (14).
3. Install the upper front arms (14) onto the lower front arms (12). Secure the upper suspension arms (12 & 14) using the front body posts (15) and (2) 3x14mm round head self-tapping screws (R).
4. Install the front axles (59) into the front knuckle arms (19&20). Install a 3.8mm pivot ball (55) into the outer hole of each of the front knuckle arms (19&20)
5. Attach the knuckle arm assemblies to the arms using the 3mm king pins (58). Install the front suspension spring (57) onto the king pin (58) below the lower suspension arm (12) as shown. Secure the spring (57) onto the king pin (58) using (2) 2mm e-clips (N). Install a 2mm e-clip (N) onto the top of each king pin (58) to secure.
6. Install the front body mount (16) to the arm assembly with two 3x15mm self-tapping screws (R).
7. Install the steering servo mount (11) to the main chassis (38) using (2) 3x10mm flat head self-tapping screws (B).

### MAIN CHASSIS

- ❑ 1. Secure the center battery clip (10) to the main chassis (38) and motor plate (39) using (4) 3x8mm flat head self-tapping screws (A).
- ❑ 2. Secure the battery end holders (21) to the sides of the main chassis (38) using (4) 3x10mm flat head self-tapping screws (B).
- ❑ 3. Attach the upper plate support (8) to the rear of the main chassis (38) and the front of the, motor plate (39) using (2) 3x10mm flat head self-tapping screws (B) in the main chassis (38). Install a 3mm o-ring (E) between the motor plate (39) and the upper plate support (8) then secure the upper plate support (8) to the motor plate using (1) 3x15mm flat head machine screw (F) and (1) 3mm nylon lock nut (D). Install (2) 3.8mm pivot balls (55) into the upper plate support (8).

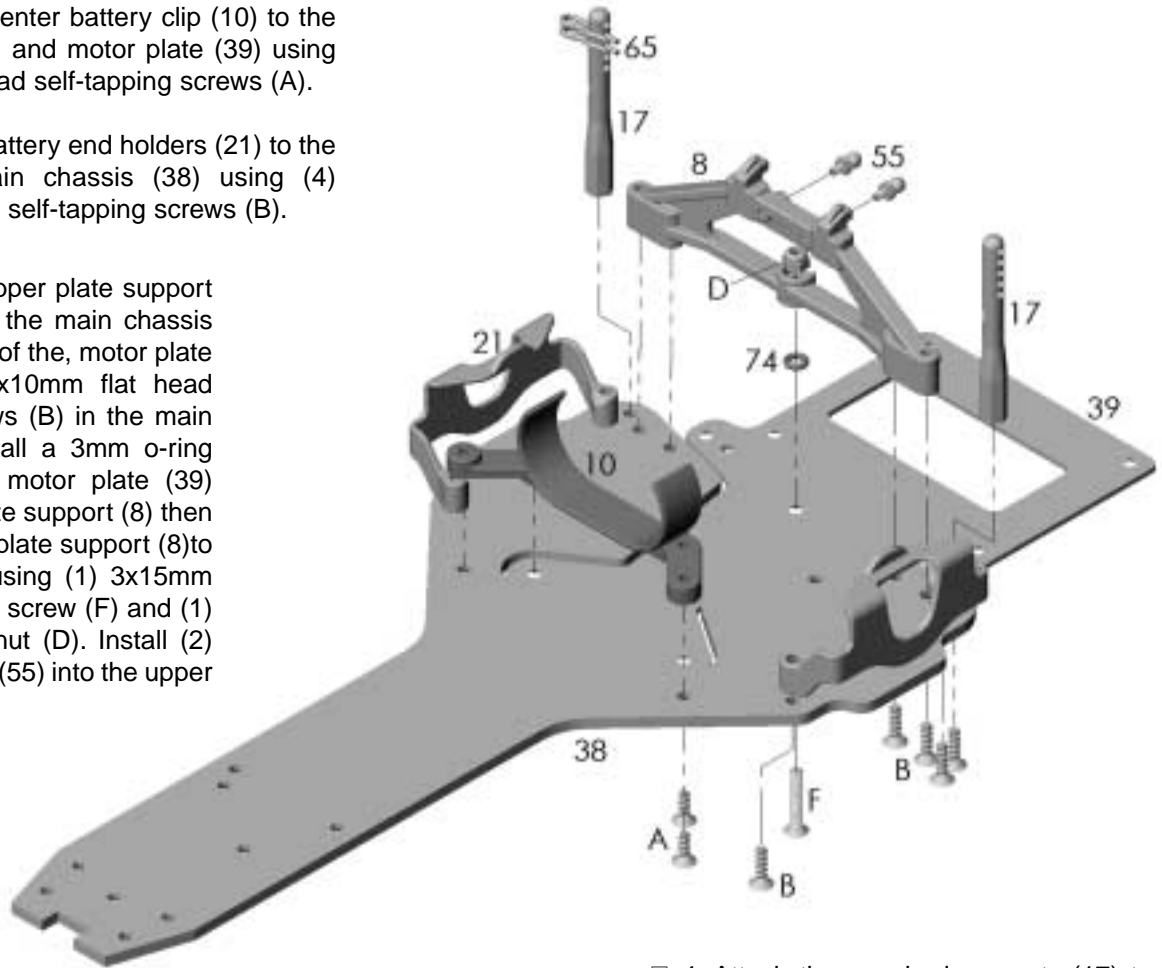

- ❑ 4. Attach the rear body mounts (17) to the main chassis (38) using (2) 3x10mm flat head self-tapping screws (B).



### MAIN SHOCK

- ❑ 1. Install the shock shaft (48) into the main shock body (32).
- ❑ 2. Install the shock cap (31) onto the shock body (32).
- ❑ 3. Thread the adjusting nut (33) onto the shock body (32).
- ❑ 4. Install the spring (49) onto the shock shaft (32) below the adjusting nut (33) then, secure the spring onto the shock body by threading the shock end (34) onto the shock shaft (48).

### SIDE SHOCKS

- ❑ 1. Thread the side shock adjusting nut (37) onto the side shock body (35).
- ❑ 2. Install the side shock spring (50) onto the side shock body (35).
- ❑ 3. Insert the side shock shaft (36) into the bottom of the side shock body (35).

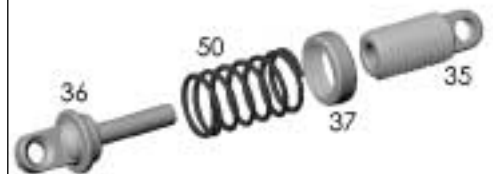

### MOTOR PLATE ASSEMBLY

- ❑ 1. Install the two side shock mounts (9) onto the rear plate using (2) 3x10mm flat head self-tapping screws (B).
- ❑ 2. Attach the bottoms of the side shocks to the side shock mounts (9) using (2) 3x8mm pan head self-tapping screws (C).
- ❑ 3. Snap the tops of the side shocks onto the 3.8mm pivot balls (55) installed in the upper plate support (8).
- ❑ 4. Install a 6x12 bearing into each of the pod sides (4&5).
- ❑ 5. Attach the motor pod front (7) onto the left pod side (4) using (2) 3x10mm pan head self-tapping screws (J).
- ❑ 6. Attach the right pod side (5) to the motor pod front (7) using (2) 3x10mm pan head self-tapping screws (J).

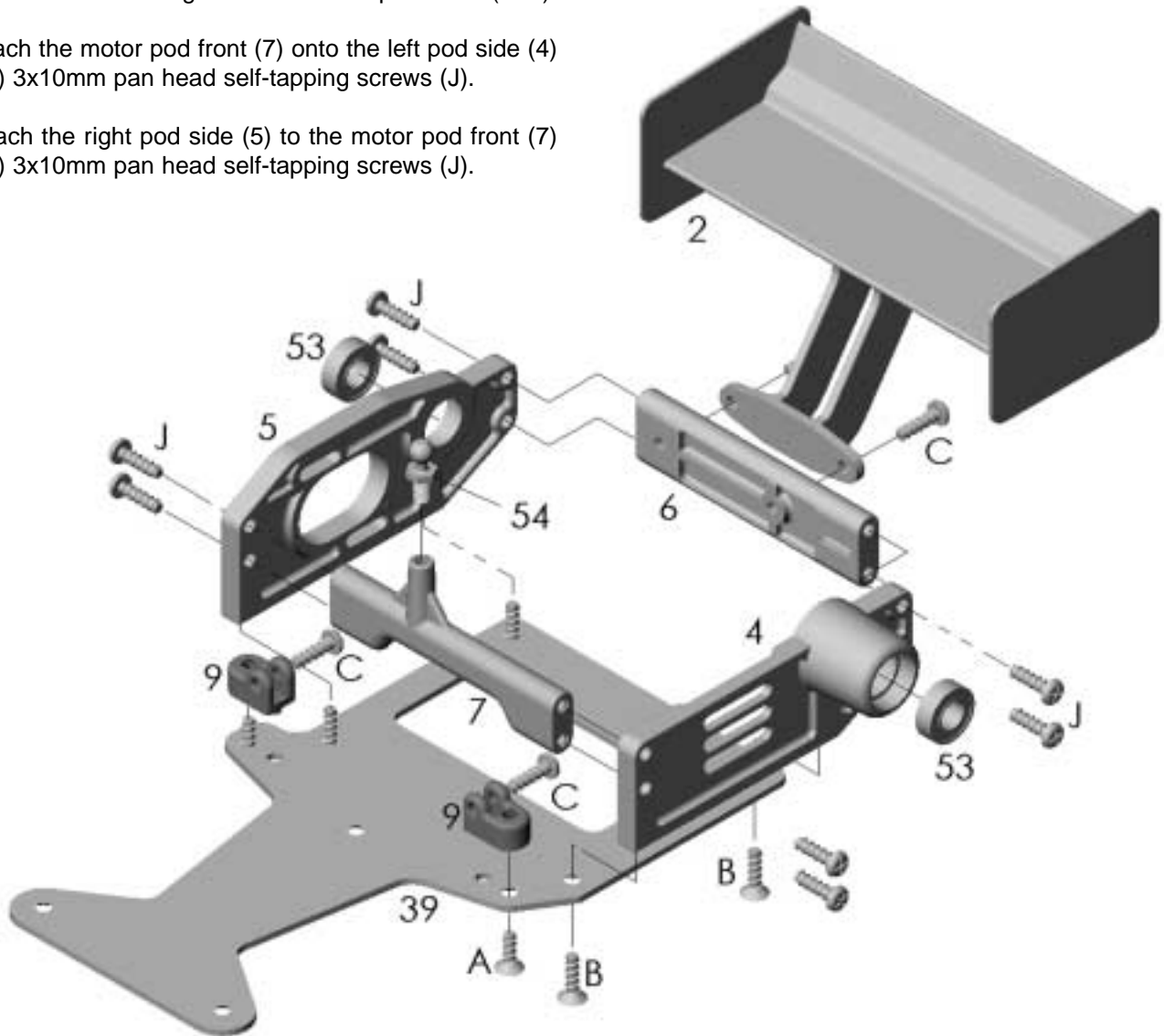

- ❑ 7. Install the motor pod rear (6) onto the left and right pod sides using (4) 3x10mm pan head self-tapping screws (J).
- ❑ 8. Secure the pod to the motor plate (39) using (4) 3x10mm flat head self-tapping screws (J).
- ❑ 9. Secure the rear wing (2) to the motor pod rear (6) using (2) 3x8mm pan head self-tapping screws (C).
- ❑ 10. Attach 4.7mm pivot ball (54) to the motor pod front.

### UPPER PLATE

- ❑ 1. Attach the antenna mount (18) to the upper plate (40) using a 3x8mm pan head self-tapping screw (C).
- ❑ 2. Install a 4.7mm pivot ball (56) into the upper plate (40) and secure it in place with a 3mm nut (P) on the bottom side of the upper plate (40).

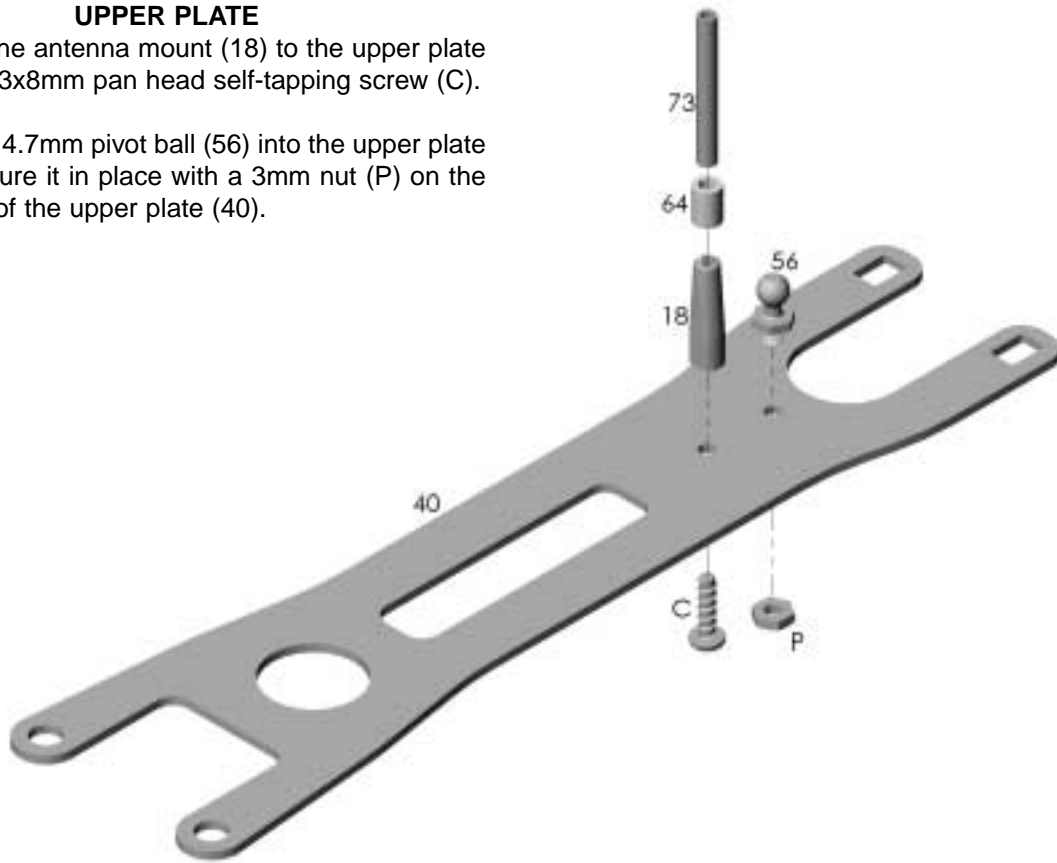

### MAIN SHOCK INSTALLATION

- ❑ 1. Attach the bottom of the main shock to the 4.7mm pivot ball (56) on the motor pod front (7).
- ❑ 2. Attach the top of the main shock to the 4.7mm pivot ball (54) installed on the upper plate (40).

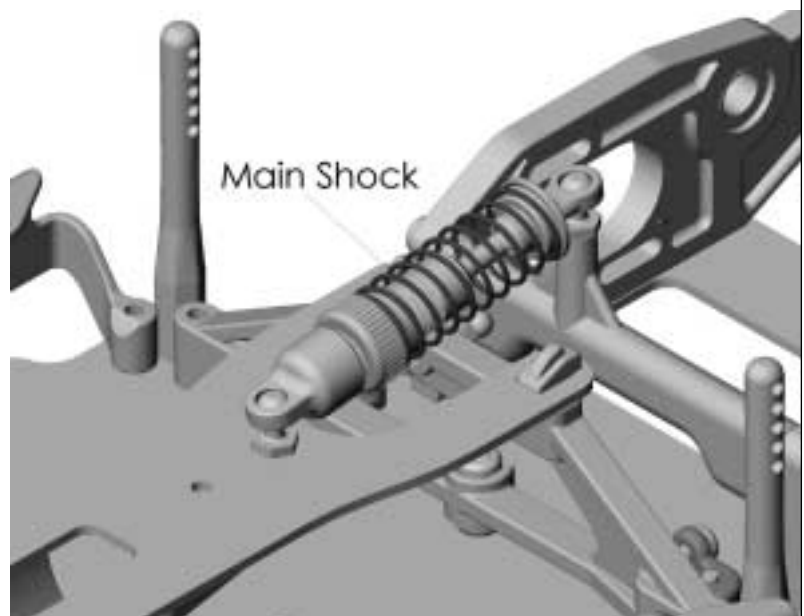

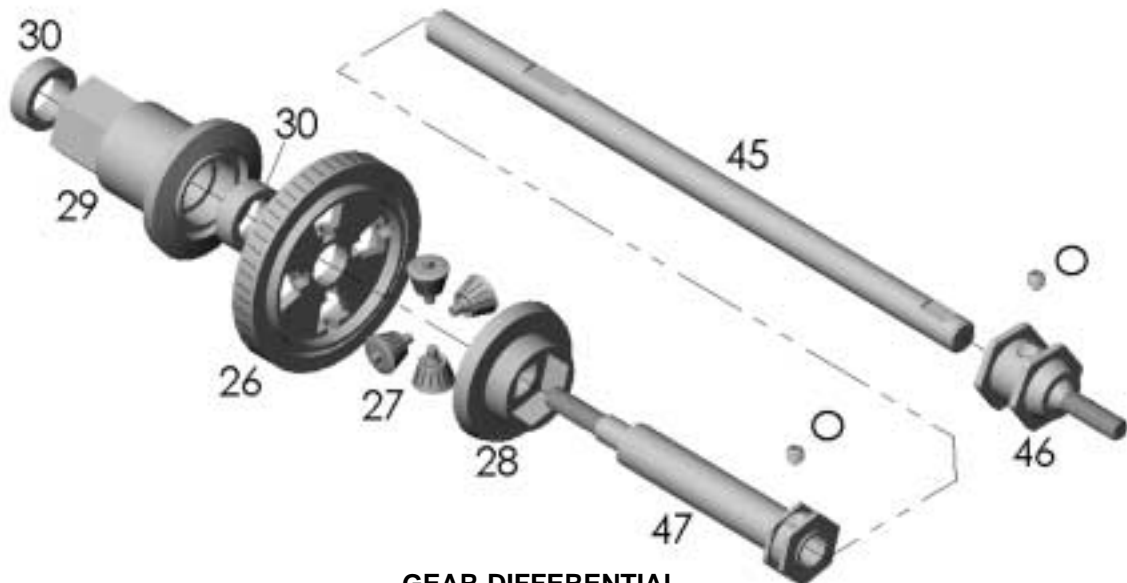

### GEAR DIFFERENTIAL

- ❑ 1. Locate the rear axle (45) and install the right wheel hub (47) onto the end with the flat spot farthest from the end of the shaft. Install and tighten the 3mm set screw (O) in the right wheel hub. **Note: Make sure the set screw is tightened onto the flat spot of the rear axle.**
- ❑ 2. Install the diff inner (28) onto the right wheel hub (47). Make sure the hex in the diff inner (28) keys onto the hex on the right wheel hub (47).
- ❑ 3. Install the (4) diff internal bevel gears (27) into the spur gear (26).
- ❑ 4. Install the spur gear assembly onto the right wheel hub (47) so that it meshes with the already installed bevel gears (27). Note: The raised inner portion of the spur gear should be away from the diff internal bevel gears.
- ❑ 5. Insert the plastic bushings (30) into the ends of the diff outer.
- ❑ 6. Install the diff outer (29) onto the right wheel hub.
- ❑ 7. Install the axle and differential assembly through the rear pod. The differential should be located on the same side as the motor pinion (the right side when viewing the car from the rear). **Note: Make sure the bearings are still fully seated after the axle is installed.**
- ❑ 8. Secure the axle assembly into the pod by attaching the left wheel hub (46) to the left side (when viewed from the rear) of the axle. Secure the left wheel hub (46) to the axle using a 3mm set screw (O). **Note: Make sure the set screw tightens down onto the flat spot on the axle.**

### INLINE BATTERY PLACEMENT CONVERSION

To convert the Delphi Indy car so that the battery runs inline with the chassis use the following steps.

- ❑ 1. Remove the battery end holders (21) from the main chassis (38).

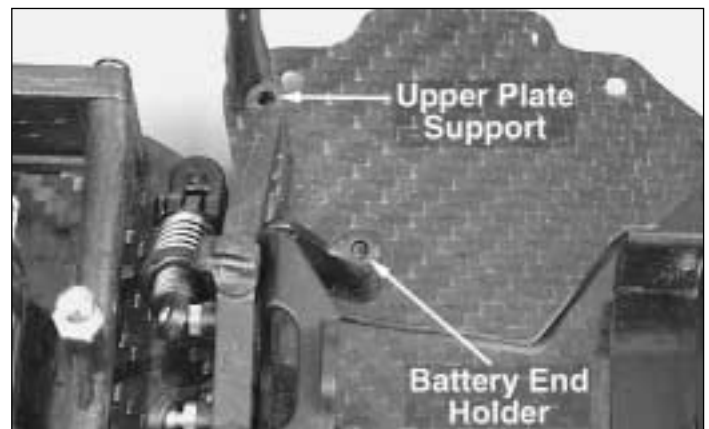

- ❑ 2. Install (1) of the battery end holders (21) directly in front of the upper plate support (8).

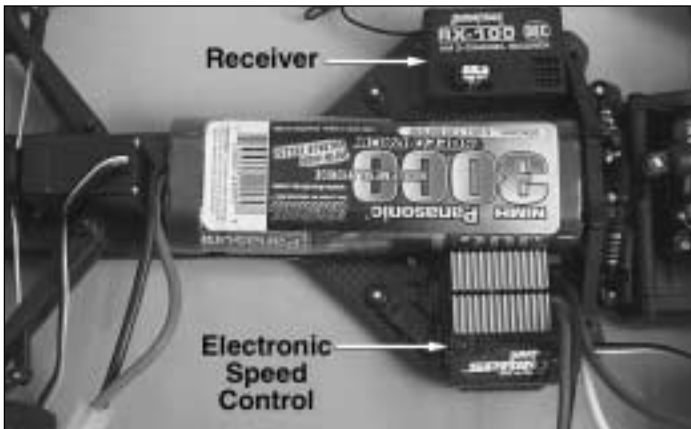
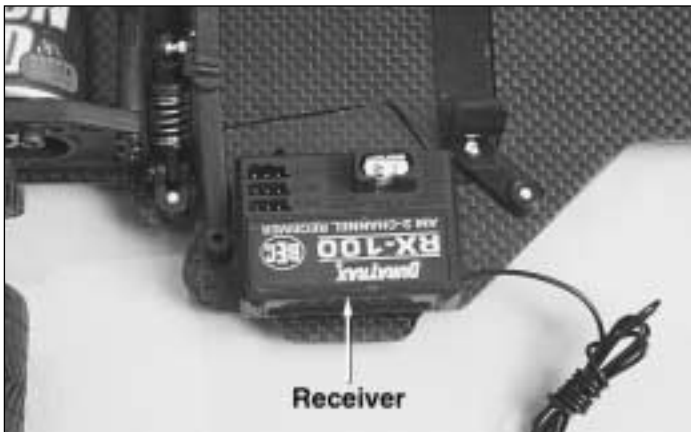
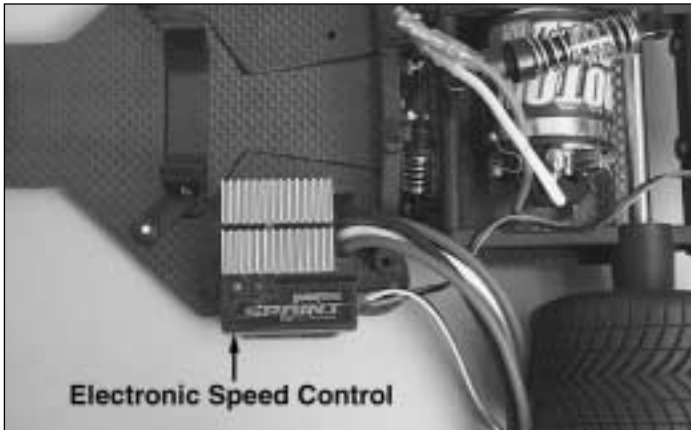
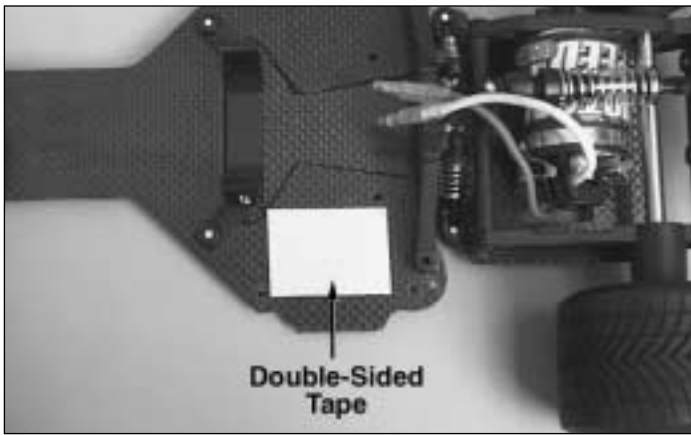

□ 3. Remove the ESC and receiver from behind the steering servo and install them onto the sides of the main chassis using double sided tape.

□ 4. Attach a small piece of hook and loop material (not included) onto the main chassis located behind the steering servo and the other half of hook and loop on the battery. Make sure to place the hook and loop onto the battery where it will contact the piece that was installed on the chassis.  
**Note: This is to help eliminate movement of the battery.**

## MAINTENANCE TIPS

### BEFORE EACH RUN

- 1. Check to make sure that all screws are tight and there are not any screws missing.
- 2. Check to make sure that the transmitter batteries are good.
- 3. Check to make sure that all of the moving parts of the Delphi Indy car move freely and do not bind.
- 4. Check for broken or damaged parts. Replace any broken or damaged parts before running the Delphi Indy car. Running of the Delphi Indy car with broken or damaged parts could result in damage to other parts.
- 5. Check to make sure that the receiver and speed control are still properly secured to the chassis.
- 6. Check to make sure that all wires are properly connected.

### AFTER EACH RUN

- 1. Clean any large deposits of dirt or debris from the chassis and moving parts.
- 2. Disconnect and remove the battery from the vehicle.
- 3. Check for any broken or damaged parts.

### AFTER EVERY TEN RUNS

- 1. Check to make sure that the bearings are free of dirt and debris and roll smoothly.
- 2. Check the motor brushes for wear. If the motor brushes are severely worn or discolored they should be replaced.
- 3. Check for buildup and wear on the bushings of the motor. If the bushings are dirty, use DuraTrax Power Shot™ motor cleaner to clean them. If the bushings are worn, replace them.
- 4. Make sure the servo saver is free moving and does not bind. This will help prevent stripping of the servo during running.
- 5. Check for proper gear mesh between the spur and pinion gear. Too tight and it will cause a lot of drag and poor performance. Too loose and you will risk stripping the gear teeth.

## TUNING GUIDE

Use this guide to help you achieve the best performance from your Delphi Indy car. Before you begin, make sure that all the screws are tight that you have equal lengths from side to side for the shock adjusters and steering tie rods.

**TIP:** When tuning your Delphi Indy car, only make one change at a time and then test. This will make it much easier to keep track of changes. We also recommend you keep a log book close by so you can record what you did and the effect it made to the car.

### FRONT TOE-IN AND TOE-OUT ALIGNMENT:

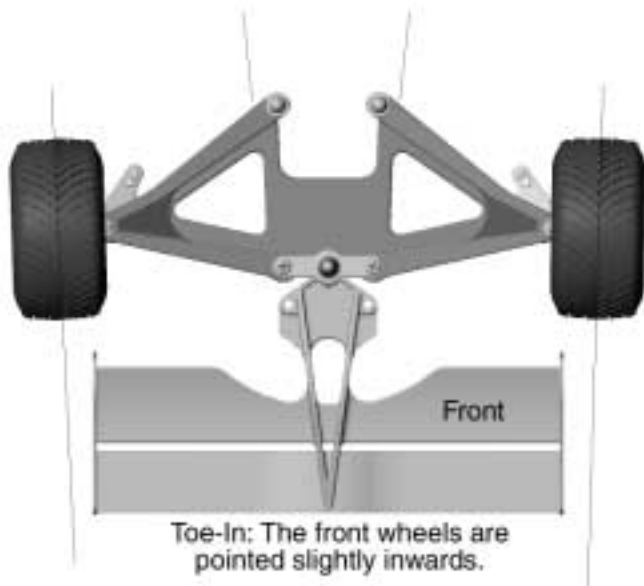

Toe-in and toe-out refers to the angle at which the tires point when viewed from above. Toe-in increases stability under acceleration and helps straight away tracking. Toe-out will increase steering going into corners, but will decrease the overall stability during acceleration. The front typically is set-up with 0 to -2 degrees of toe-in. Only use a toe-out setting when you are running on a short track with many turns and few straights.

### BATTERY PLACEMENT

The battery placement of the Delphi Indy car can be adjusted by moving the location of the electronics. With the battery positioned from side to side, the car will have more weight towards the rear. This results in better rear traction but slightly reduced steering agility. This is a good placement for oval tracks. With the battery positioned down the center, more weight is placed on the front wheels allowing quicker turning response. The weight is also positioned closer to the centerline of the chassis. This will produce less chassis roll and a more consistent feeling car through the turns. This position is good for road course tracks with many turns.

### RIDE HEIGHT

The ride height of the Delphi Indy car will effect how weight is transferred from side to side and from front to back. Generally speaking the lower the ride height, the better the car will handle. The ride height of the Delphi Indy car is adjustable by

installing the ride height spacers under the rear motor pod and the front suspension arm. Lowering the front ride height will increase steering response due to more weight on the front wheels. Lowering the rear ride height will increase rear traction and reduce steering response due to more weight on the rear wheels. **Note:** If you are running on rough surfaces with many cracks and rocks, a higher ride height will be desired for clearance. If your surface is smooth, run a lower ride height.

### REAR PLATE ADJUSTMENT

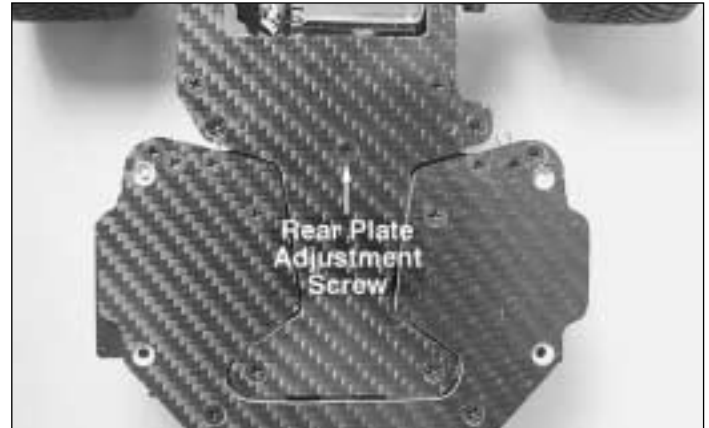

The side to side stiffness of the rear plate is easily adjustable by tightening or loosening the center pivot. A stiff setting will give you a more consistant feel but slightly less rear grip (the wheels may spin out easier but it won't break-loose as suddenly). A softer setting will increase initial rear grip but may tend to break loose more suddenly. Typically a tighter setting is more predictable at high speeds and softer setting more predictable at lower speeds.

### DIFFERENTIAL ADJUSTMENT

The Delphi Indy car comes with a gear differential for durability and easy adjustment. The diff can be set looser or tighter by simply adjusting the right rear tire nut. Running the diff tighter will reduce steering response and increase understeer slightly (push). This is good for oval racing where turns are wide and sweeping. Runing the diff a little loose will increase steering but may cause oversteer (loose). **CAUTION!** Do not loosen the diff too much or the internal diff gears could strip. As a rule of thumb, a tighter diff is usually easier to drive.

### SIDE SHOCK ADJUSTMENT FOR TRACKING

The side shocks have adjustable collars which allow you to add more preload to the left and right side independently. Use this adjustment to tune the car to run straight and true during acceleration. First make sure the steering trim is centered correctly. Run the car at medium speed and let it coast. Adjust the steering trim so the car tracks straight. Next, from a stop, accelerate and take note of the direction the car tends to pull. If it consistently pulls right, adjust the right side shock adjust down a bit and the left side shock adjuster up a bit. This tuning adjustment will allow more aggressive weight transfer to the right wheel giving this wheel a little more initial traction. **Note:** Tires can effect how the car will track as well. If your left side tires are worn more than the right side, the car may not track straight under acceleration.

### OPTIONAL SHOCK SPRINGS

Some basic guidelines when setting up the Delphi Indy car are that if the rear end is stiff (by using harder rear springs or softer front springs) it will give the car more steering and have less rear traction. Stiffening the front will result in less steering and more rear traction. (Note: Just changing the position of the threaded shock pre-load adjusters will only result in ride-height change. It does not change the spring tension).

### TIRE TIPS

Typical with pavement style cars like the Delphi Indy car, tire selection is the most important tuning component you can make. Installing softer compound tires (whether rubber or foam) will give you more traction but will wear faster. Installing harder compound tires will result in less traction but better wear and durability. Typically, choosing a slightly softer tire for

the rear and a harder tire for the front will give you a car that will under-steer or push. This is a good set up when learning to race as it is much easier to drive. Use the many available tire compound options to tune your car to your driving style. For example, if your car doesn't turn in hard enough at the end of the straight (pushes), try using softer front tires. Conversely, if your car tends to dive quickly into corner and breaks loose the rear end easily, use a harder compound front tire. If your car tends to break loose easily in tight high speed corners. Try using softer rear tires.

There are many different settings for the Delphi Indy car. An important tip is to only do one thing at a time and test run each.

***Have fun!!!***

## OTHER PRODUCTS AVAILABLE FROM DURATRAX



IntelliPeak™ Pulse Chargers give each battery a full charge, whether it's a NiCd or a NiMH pack. Use at home or at the track, to charge, discharge, or even cycle a pack automatically. 1-year warranty.

- DTXP4100** AC/DC Pulse Charger,
- DTXP4110** AC/DC Mini Pulse Charger,
- DTXP4120** AC/DC Deluxe Pulse Charger,
- DTXP4130** AC/DC Digital Pulse Charger



Race economically with the Shark 6-cell 1500mAh sport pack (**DTXC2030**)...or go for explosive output current and all-out speed with Sanyo 1900SCRs (**DTXC2130**)! Both are assembled and ready to run.



### DuraTrax Deluxe Field Bag (**DTXP2010**)

Keep your radio and other gear ready for action—store it in this heavy-duty black nylon field bag, with water-resistant vinyl bottom. Stitched handles, detachable shoulder straps and a zippered top add security. Measures 27" x 14" x 12-1/2".



### Pit Tech™ Deluxe Car Stand

It's a convenient work station for your cars — anywhere you want! The sturdy stand disassembles easily and stores flat...a space-saving feature for carrying in a toolbox or field bag. The plate rotates for all-sides access, and built-in holes keep shocks handy when rebuilding. An extra-large parts tray in the base offers added convenience. Molded rubber inserts grip chassis securely.

- DTXC2370** Pit Tech Deluxe Car Stand (Blue)
- DTXC2371** Pit Tech Deluxe Car Stand (Orange)
- DTXC2372** Pit Tech Deluxe Car Stand (Purple)
- DTXC2373** Pit Tech Deluxe Car Stand (Green)