

**DURATRAX**

# **STREET FORCE**™ **GP**

## **ASSEMBLY AND OPERATION MANUAL**



### **Warranty**

- DuraTrax® will warranty this kit for 90 days after the purchase date from defects in materials or workmanship. DuraTrax will either repair or replace, at no charge, the incorrectly made part.
- Make sure you **save the receipt or invoice** you were given when you bought your model! It is your proof of purchase and we must see it before we can honor the warranty.
- To return your Street Force GP for repairs covered under warranty you should send your touring car to:

Hobby Services  
1610 Interstate Drive  
Champaign, Illinois 61822  
Attn: Service Department  
Phone: (217) 398-0007 9:00 am - 5:00 pm Central Time M-F  
E-mail: [hobbyservices@hobbico.com](mailto:hobbyservices@hobbico.com)

### **Before Building:**

We want the building and operating of this vehicle to be a success, so **BEFORE** removing any parts from the parts bags please read this manual thoroughly and watch the included video to familiarize yourself with the model. If for any reason you think this model is not for you, return it to your dealer immediately. **PLEASE NOTE:** Your hobby dealer cannot accept a return on any model after assembly has begun.

## TABLE OF CONTENTS

Introduction.....	2
Safety Precautions .....	2
Helpful Hints.....	2
Stress-Tech™ Parts Guarantee.....	2
Repair Service.....	2
Specification & Description Changes.....	3
Screw Information .....	3
Required Items for Completion .....	3
Tools You Will Need.....	3
Finishing the RTR Version.....	4
Air Filter Installation.....	4
Radio Set-Up .....	4
Body Mounting .....	5
Assembly of the Pre-Built Version.....	6
Preparing the Radio System .....	6
Radio Set-Up.....	6
Air Filter Installation.....	10
Body Mounting .....	10
Carburetor Settings .....	11
Running the Engine.....	11
Breaking-In the Engine .....	12
Engine Maintenance .....	12
Performance Tuning .....	13
Maintenance Tips.....	14
Engine Trouble Shooting .....	15

## INTRODUCTION

Thank you for purchasing the DuraTrax Street Force GP. This manual contains the instructions you need to build, operate and maintain your new nitro R/C touring car. Read over this manual thoroughly before building or operating the Street Force GP.

## SAFETY PRECAUTIONS

When the safety precautions are followed, the Street Force GP will provide years of enjoyment. Use care and good sense at all times when operating this radio controlled touring car. Failure to use this vehicle in a safe, sensible manner can result in injury or damage to property. You and you alone must insure that the instructions are carefully followed and all safety precautions are obeyed.

- Do not operate the Street Force GP near people. Spectators should be behind the driver or at a safe distance away from the vehicle.
- The engine and exhaust produces quite a bit of noise. If you are disturbed by the amount of noise this touring car produces, wear ear protection such as earplugs. Do not run this vehicle when or where it can disturb others.
- The engine and exhaust can become very hot. Avoid touching any of these parts during use and until they have cooled down.

- Model engine fuel is poisonous. Make sure you read and follow all of the precautions on the fuel container. Keep fuel out of the reach of children.
- Model engine fuel is flammable and when ignited has a flame that is difficult to see. Avoid sparks, flames, smoking, or any other ignition source when fuel is near.
- The engine emits carbon dioxide just like real cars. Do not operate this model indoors.
- Before turning on the transmitter, make sure that no one else is on your frequency.

## HELPFUL HINTS

- Avoid working over a deep pile carpet. If you drop a small part or screw, it will be difficult to find.
- Place a mat or towel over your work surface. This will prevent parts from rolling off and will protect the work surface.
- Avoid running the touring car in cold weather. The plastic and metal parts can become brittle at low temperatures. In addition, grease and oil become thick, causing premature wear and poor performance.
- Test fit all parts before attaching them permanently.

## STRESS-TECH™ PARTS GUARANTEE

We have engineered the Street Force GP to take the high speed abuse that makes R/C cars fun. We are so confident of the quality and durability of the Stress-Tech™ plastic parts that we will replace any Stress-Tech plastic part you break during the first 6 months you own the touring car. Just send in the part to us and we will send you a **Free** replacement. Please see the Street Force GP parts list for the items covered under the Stress-Tech guarantee.

To receive your free replacement part please send the following to the Hobby Services address listed on the cover of this manual:

- The broken part must be included.
- The part number and description of the broken part.
- Dated copy of your invoice or purchase receipt.
- Your name, phone number and shipping address.

## REPAIR SERVICE

Repair service is available anytime.

- After the 90 day warranty, you can still have your Street Force GP repaired for a small charge by the experts at DuraTrax's authorized repair facility, Hobby Services, at the address listed on the front page of this manual.

To speed up the repair process, please follow the instructions listed below.

1. Under most circumstances return the **ENTIRE** system: touring car and radio. The exception would be sending in a Stress-Tech part. See the instructions under Stress-Tech Guarantee.
2. Make sure the transmitter is turned off, all batteries are removed and fuel is drained from the tank.
3. Send written instructions which include: a list of all items returned, a **THOROUGH** explanation of the problem, the service needed and your phone number during the day. If you expect the repair to be covered under warranty, be sure to include a proof of date of purchase (your store receipt or purchase invoice).
4. Also be sure to include your full return address.

## SPECIFICATION & DESCRIPTION CHANGES

All pictures, descriptions and specifications found in this instruction manual are subject to change without notice. DuraTrax maintains no responsibility for inadvertent errors in this manual.

## SCREW INFORMATION

Do not use too much force when tightening self-tapping screws into plastic. Overtightening will cause the threads in the plastic to strip. We recommend that you stop turning a self-tapping screw when you feel some resistance as the head of the screw comes in contact with the plastic. Avoid using powered screwdrivers when assembling this kit. They tend to overtighten the screws. Do not use thread locking compound on any self-tapping screws. The thread locking compound may damage the plastic. **IMPORTANT:** Use thread lock on any fastener that is threaded into metal or fastened with a nut. Vibration from the engine will cause the screws to loosen if thread locking compound is not used.

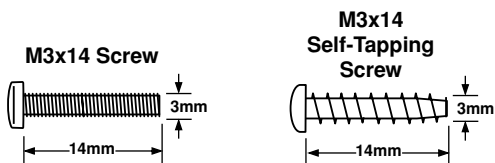

## REQUIRED ITEMS FOR COMPLETION

To operate the Street Force GP these items are required:

- Fuel (DuraTrax Red Alert fuel - DTXP0520)
- Air Filter Oil
- Glow plug wrench (DTXR1170)
- It is also helpful to have a couple of extra glow plugs on hand (O.S. #A3 plug - OSMG2690)
- Hobby knife (HCAR0105), #11 blades (HCAR0211)



*The Nitro Starter Pack from Duratrax (DTXP0200) includes fuel, deluxe wrench, fuel bottle, rechargeable glowplug starter and an O.S. A3 glow plug.*

**For the Pre-Built version of the Street Force GP, you will also need:**

- 2-channel radio with (2) standard servos (FUTJ20\*\*).
- (12) "AA" batteries - (4) for the receiver and (8) for the transmitter.
- Small bottle of thread locking compound (GPMR6060).

## TOOLS YOU WILL NEED

To assemble the Pre-built version (DTXC0050), you will need the following tools:

- Phillips head screwdriver (DTXR0122)
- Needle-nose pliers (DTXR0300)
- Hobby knife (HCAR0105), #11 blades (HCAR0211)

## FINISHING THE STREET FORCE GP TOURING CAR RTR VERSION (DTXD50\*\*)

### AIR FILTER INSTALLATION

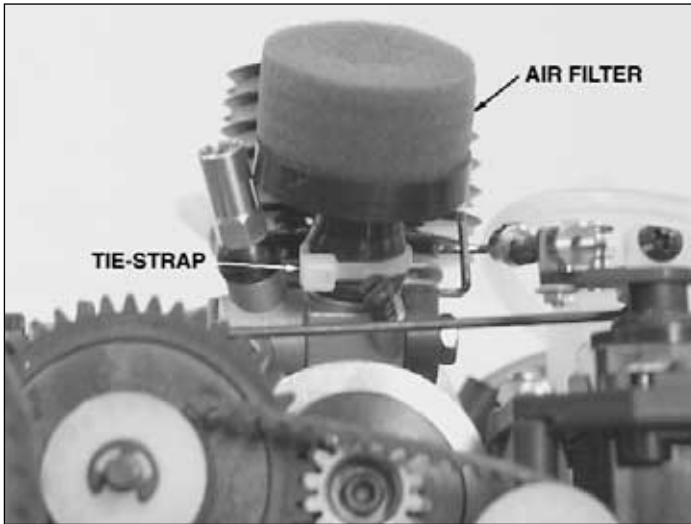

❑ 1. Install the air filter onto the carburetor. Using the included tie-strap, secure the air filter to the carburetor. Cut off any excess portion of the tie-strap to avoid interference.

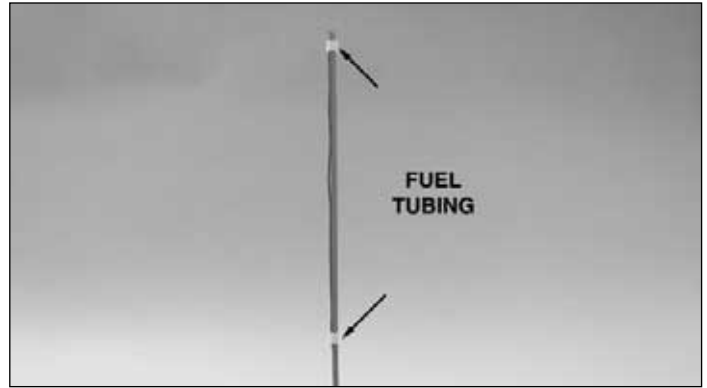

❑ 3. Frequently, there will be leftover wire protruding from the antenna tube **Do not cut or coil the antenna!** Cut two pieces of fuel tubing 1/8" long and slide them over the outside of the antenna tube and wire. This is to help hold the excess antenna onto the tube on and avoid getting the antenna wire cut in a roll over. Note the placement of the fuel tubing on the antenna tube.

### RADIO SET-UP

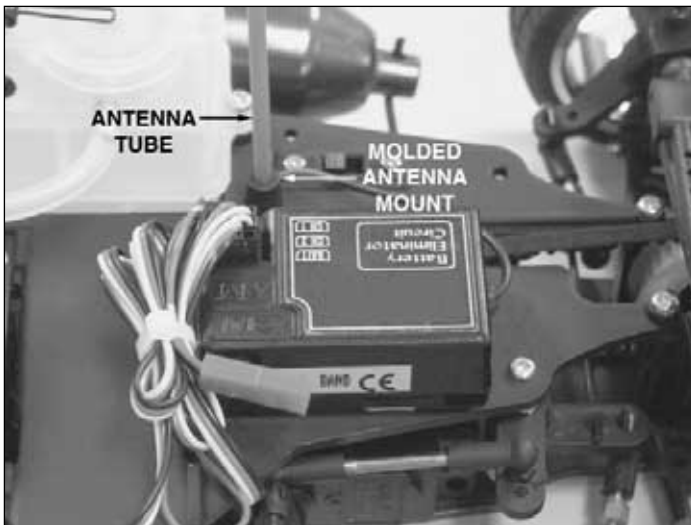

❑ 2. Remove the twist-tie from around the receiver antenna wire. Run the length of the antenna wire through your fingers to help straighten the wire out, this will make it easier to get the wire through the antenna tube. Slide the antenna wire through the antenna tube. Press the antenna tube into the antenna mount molded into the top of the radio plate.

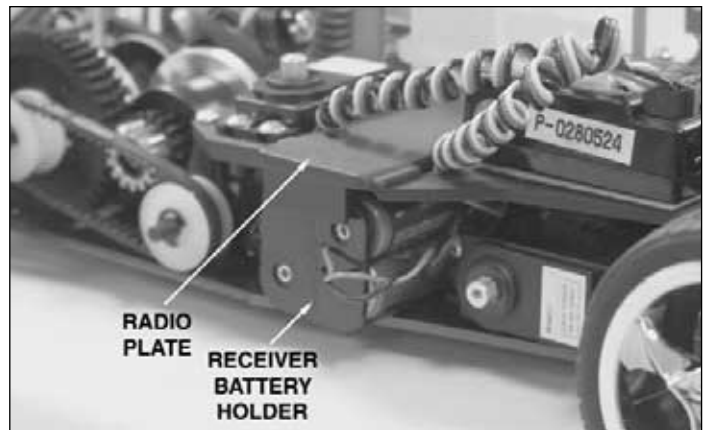
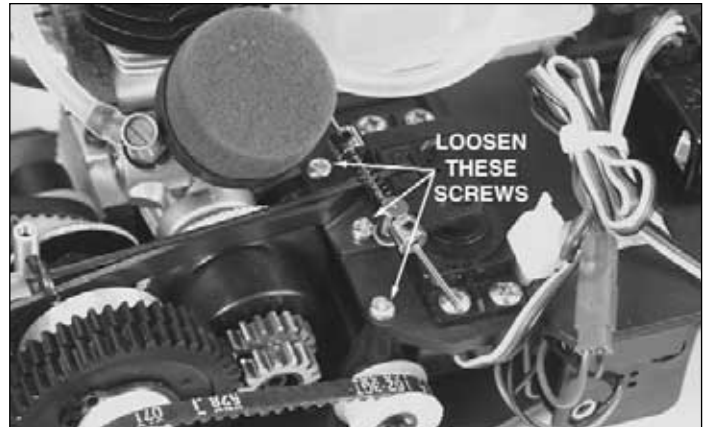

❑ 4. It may be necessary to loosen the radio plate to remove the receiver battery holder. Install 4 "AA" batteries (included) into the receiver battery holder in the configuration molded into the battery holder. Install the receiver battery back into the receiver battery holder as shown. Make sure to re-tighten the radio plate screws once the receiver battery is in place.

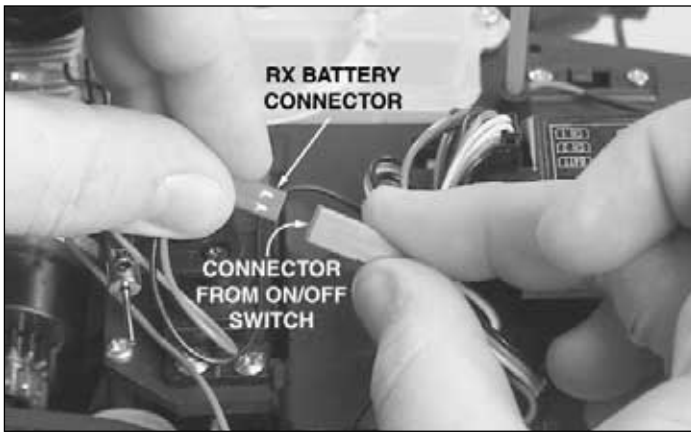

❑ 5. Plug the male end of the wire from the receiver (RX) battery into the female end from the on/off switch.

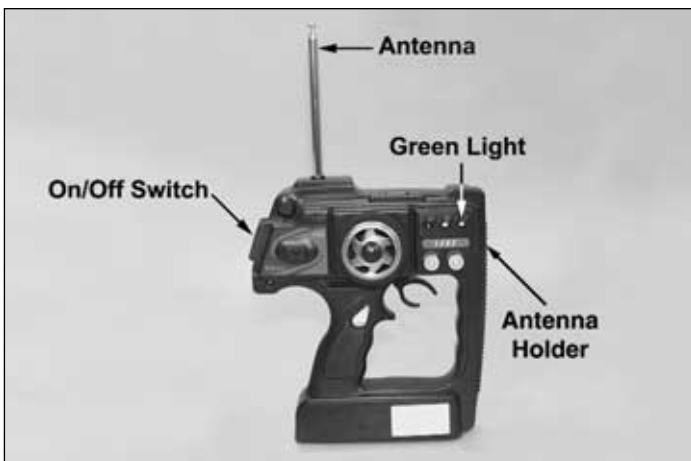

❑ 6. Remove the transmitter antenna from the holder and screw it into the hole on top of the transmitter.



❑ 7. Slide open the battery door on the bottom of the transmitter and remove the transmitter battery holder. Place 8 "AA" batteries (included) into the holder in the configuration molded into the plastic on the battery holder. Re-install the transmitter battery holder into the transmitter and re-install the battery door.

❑ 8. Turn on the transmitter (see photo with step 5). The green light should light up. If there is no light on, turn the transmitter off and check to ensure that the battery holder is making contact with the copper

contact on the inside of the battery compartment. Make sure the batteries are installed correctly. Turn the transmitter on and check for the green indicator light. If the green light appears, turn off the transmitter.

## BODY MOUNTING

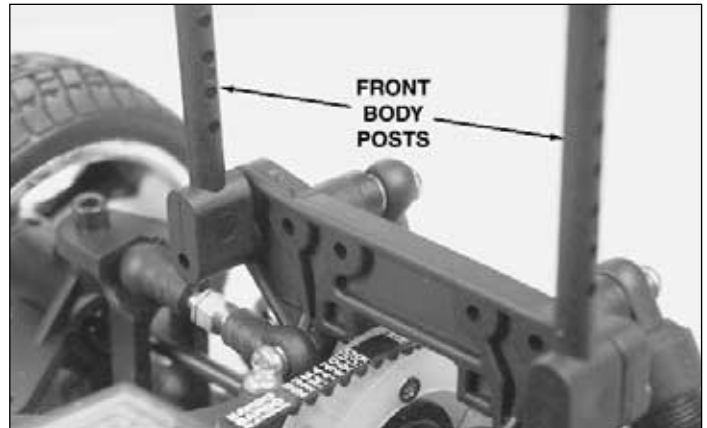
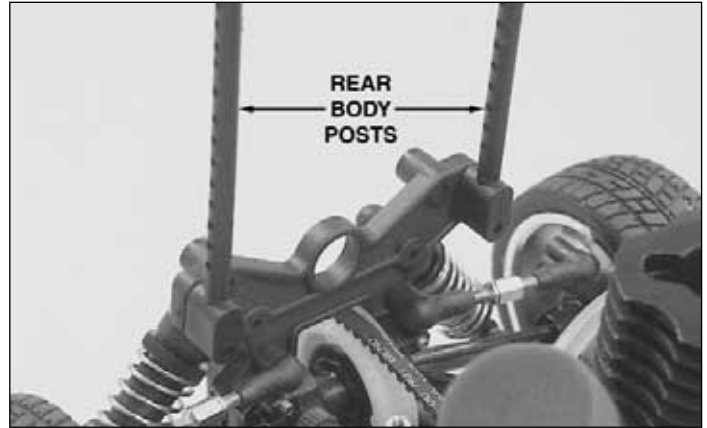

❑ 9. Raise the body posts to the upright position. Notice there is a molded pin that fits into a hole in the shock tower. This is to keep the body posts from swiveling during running. Tighten the screws in the body posts, making sure that the posts pull tight against the shock towers. You will have to remove the screws in the tops of the front shocks to get to the front body mount screws.

❑ 10. Remove the protective plastic from the outside of the body and apply the decals if desired.



❑ 11. Remove the body clips from the parts bag. On the front body posts place a body clip in the bottom hole of each post. On the rear body posts place a body clip in the third hole from the bottom in each post. Place the body onto the body mounts. On each body post place a body clip to secure the body onto the chassis. The excess body post can be trimmed off if desired.

***You are ready to go! Watch the video one more time and turn to page 11 for performance and maintenance tips.***

# ASSEMBLY OF THE STREET FORCE GP TOURING CAR PRE-BUILT VERSION (DTXC0050)

## PREPARING THE RADIO SYSTEM

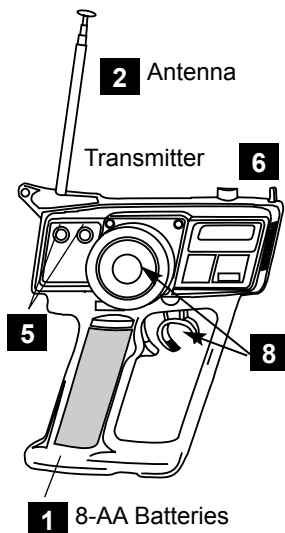

Before installing the radio system in the pre-built DuraTrax Street Force GP read the manufacturer's instruction manual and follow the instructions shown below.

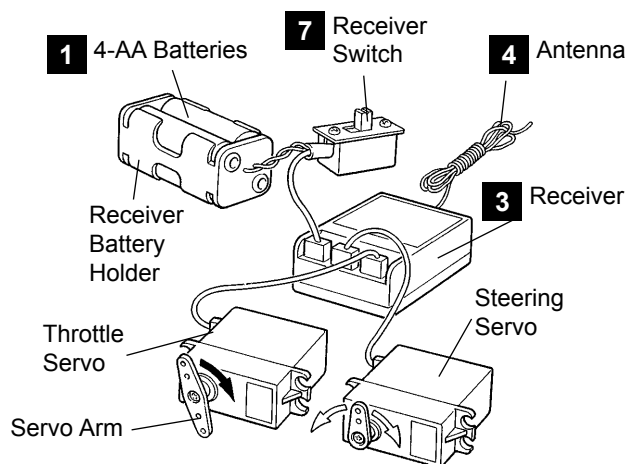

1. Install the "AA" batteries in the transmitter and the receiver holders.
2. Extend the transmitter antenna.
3. Connect the steering servo, throttle servo and receiver battery to the receiver.
4. Extend the receiver antenna.
5. Adjust the servo trims of the transmitter to the neutral position.
6. Switch on the transmitter.
7. Switch on the receiver.
8. Operate the steering and throttle control. Make sure the servo arms move in proportion to the movement of the steering wheel and throttle trigger.
9. Switch off the receiver, then the transmitter.

1. Remove the Street Force GP Touring Car from the box.

## RADIO SET-UP

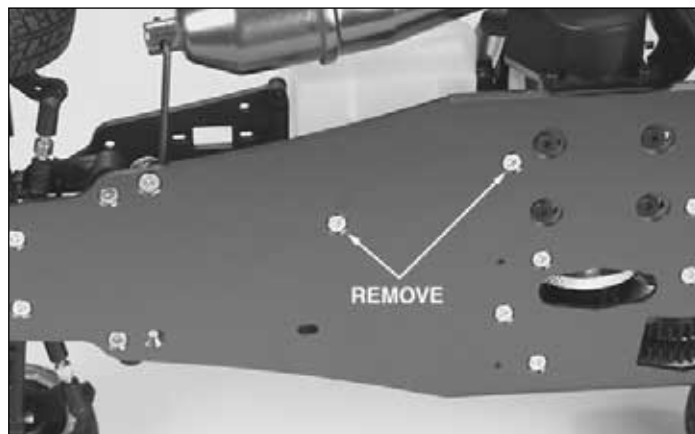
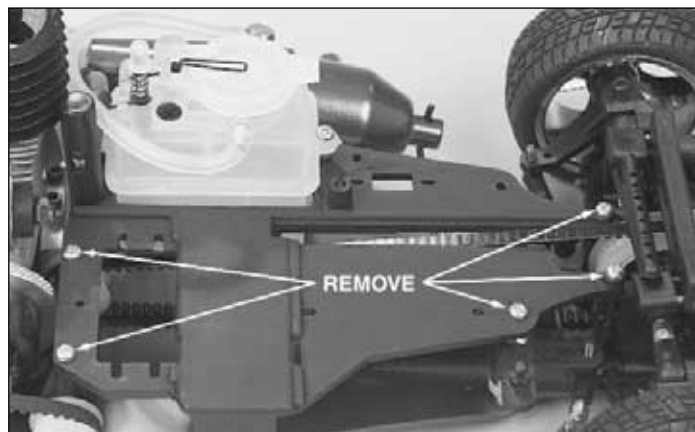

2. Remove the radio plate from the chassis by removing the 7 screws as indicated in the above photos.



3. Install the on/off switch into the slot in front of the fuel tank. Install the switch up through the bottom of the radio plate, then install the face plate onto the top of the radio plate. Re-install the two screws through the face plate and into the switch to secure it to the radio plate. Be careful to put the switch plate on correctly with respect to on and off switch positions.

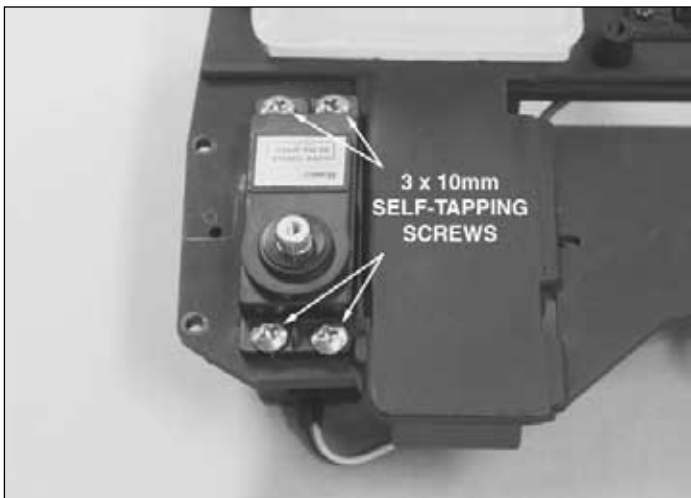
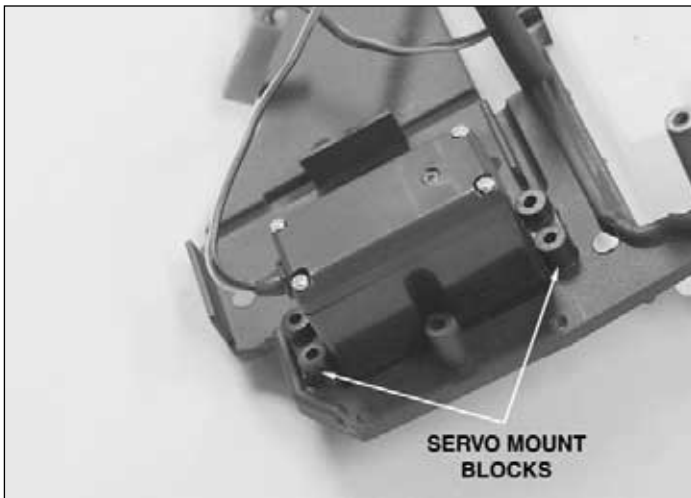

❑ 4. Install the throttle/brake servo into the slot next to the fuel tank. Place the two servo mount blocks onto the bottom of the radio plate. Then install the four 3x10mm self-tapping screws through the servo into the servo mounts. Route the servo wire through the slotted hole between the servo and the receiver battery holder.

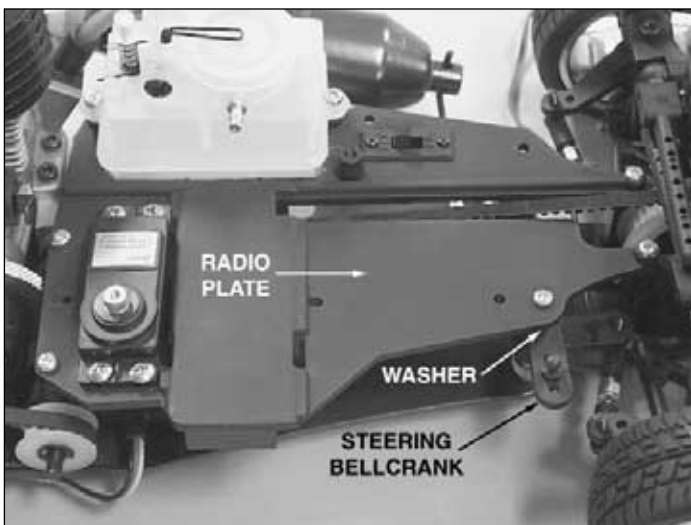

❑ 5. Reinstall the radio plate onto the chassis. Make sure to reinstall the washer between the steering bellcrank and the radio plate.

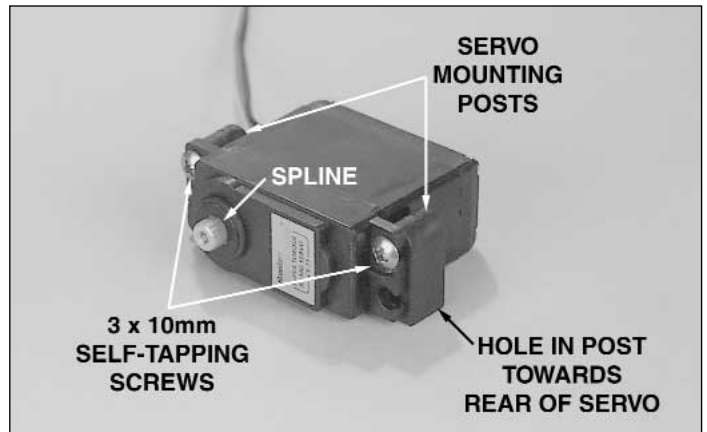

❑ 6. Install the two servo mounting posts onto the steering servo as shown (note location of servo spline). Note that the hole in the bottom of the servo mounting posts are off-center. Install the posts with the hole in the bottom of the post as shown in the photo. This is to help prevent the servo from hitting the center belt.

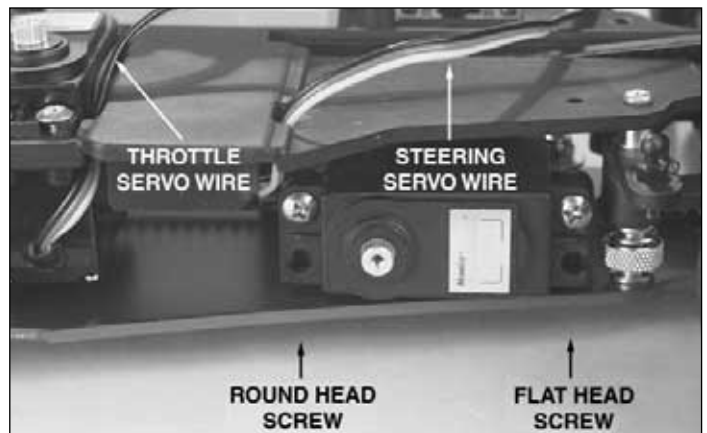

❑ 7. Install the steering servo onto the chassis from underneath using a 3x10mm flat head self-tapping screw in the front hole which is countersunk and a 3x10mm round head self-tapping screw in the slotted rear mounting hole. Route the steering servo wire through the slotted hole between the steering servo and the receiver battery holder.

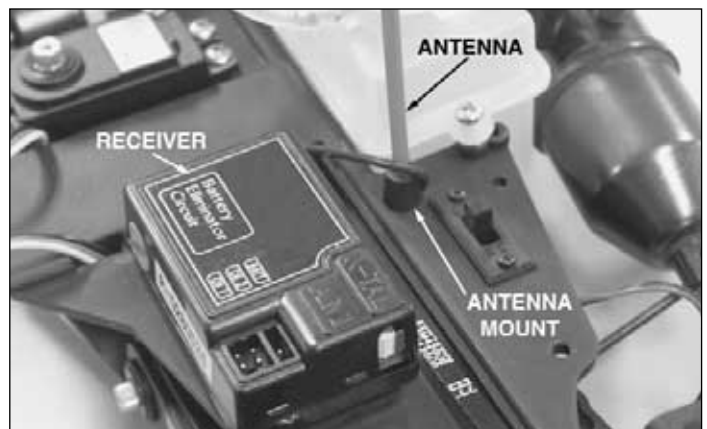

❑ 8. Install the receiver using the included double-sided tape onto the top of the radio plate as shown. Run the length of the antenna wire through your fingers

to help straighten the wire out, this will make it easier to get the wire through the antenna tube. Slide the antenna wire through the antenna tube. Press the antenna tube into the antenna mount molded into the top of the radio plate.



9. Frequently, there will be leftover wire protruding from the antenna tube **Do not cut or coil the antenna!** Cut two pieces of fuel tubing 1/8" long and slide them over the outside of the antenna tube and wire. This is to help hold the excess antenna onto the tube on and avoid getting the antenna wire cut in a roll over. Note the placement of the fuel tubing on the antenna tube.

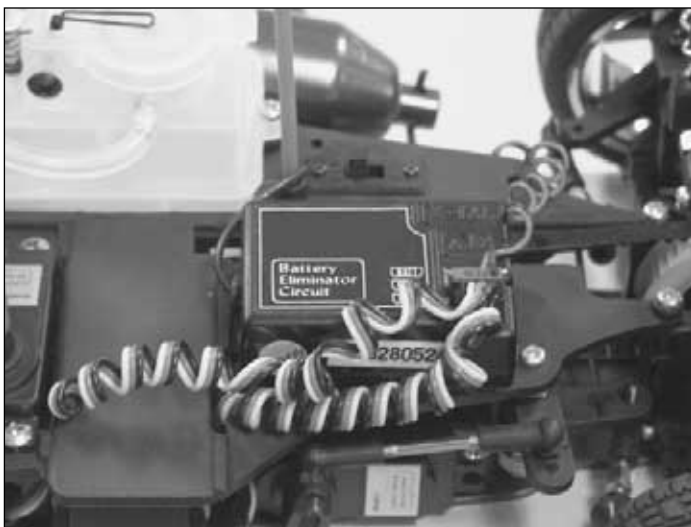

10. Plug the switch wire into the battery (batt) slot on the receiver. Plug the steering servo and throttle servo wires into the receiver. See your radio instructions to determine which channel is steering and which is throttle.

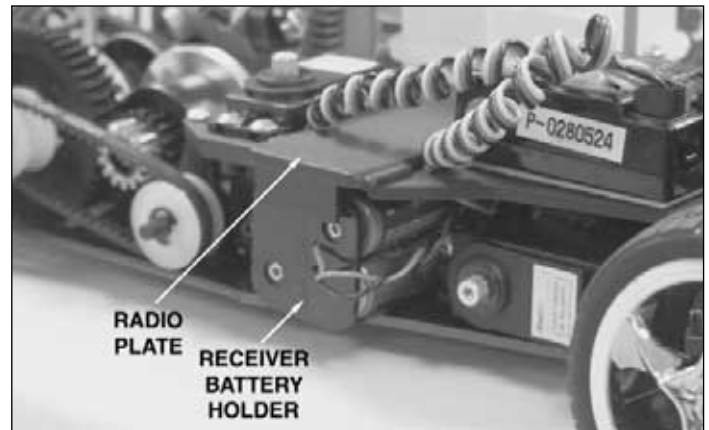
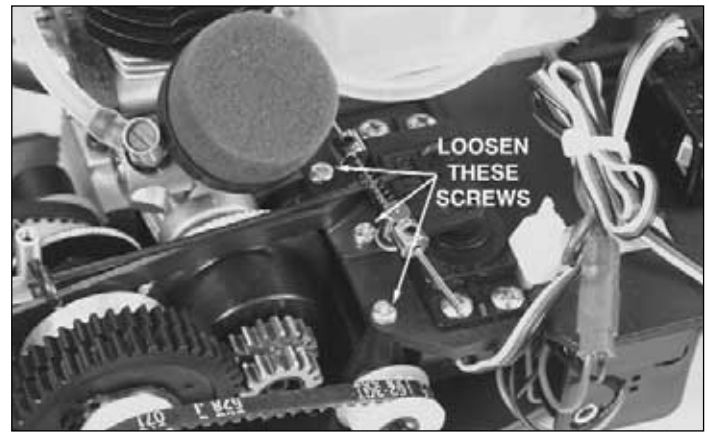

11. Install the receiver battery into the receiver battery holder as shown. It may be necessary to loosen the radio plate slightly to fit the receiver battery in. Make sure to re-tighten the radio plate screws once the receiver battery is in.

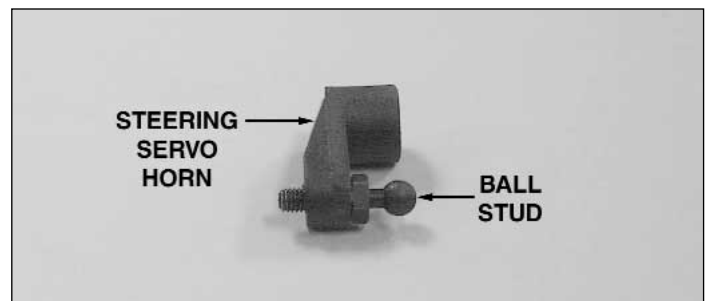

12. Thread the ball stud into the correct servo horn (included) for your steering servo as shown.

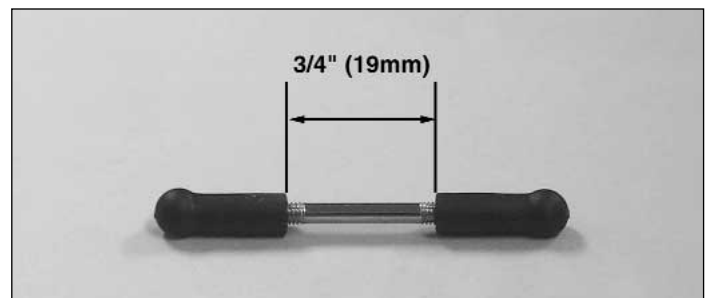

13. Thread the two ball ends onto the steel rod. There should be 19mm or 3/4" between the two ball ends.



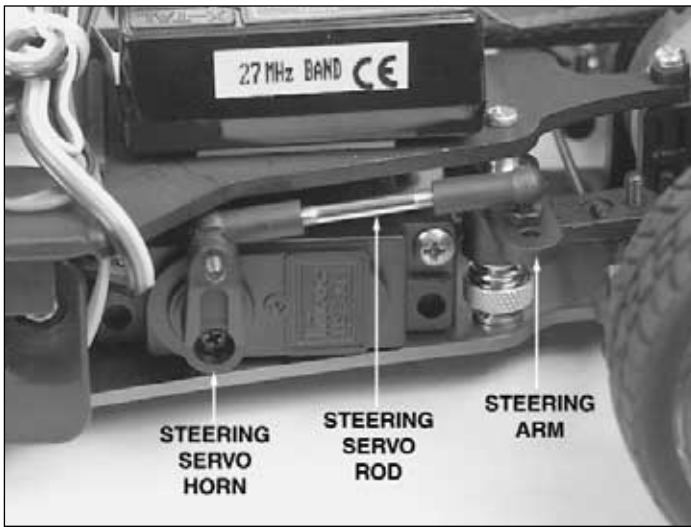

□ 14. Snap one end of the rod onto the steering servo horn. Snap the other end onto the steering arm. Turn the transmitter on and center the steering trims. Install the steering servo horn onto the steering servo as shown. Then turn the transmitter and receiver off.

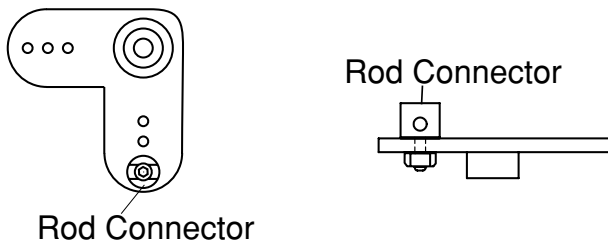

□ 15. Install the rod connector into the hole farthest away from the center on the short servo horn (included). **Note: This hole is slightly enlarged.** Place the small metal washer and 2mm nut onto the bottom of the rod connector. Make sure not to over-tighten the nut, the rod connector must swivel freely. Apply a small amount of thread lock onto the nut to prevent it from falling off during running.

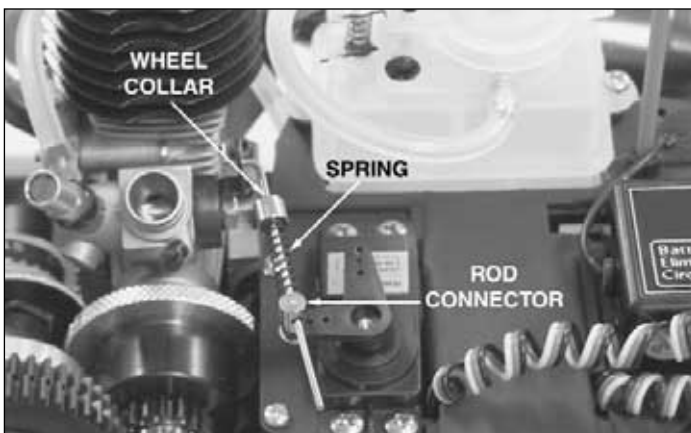

□ 16. Locate the small rod with a z-bend at one end. Install the z-bend end of the rod into the lower hole of the throttle arm on the carburetor. Turn the transmitter

on again and center the throttle trim on it. Install a set screw into one of the wheel collars. **NOTE:** Only thread the set screw in slightly so that the wheel collar will slide over the throttle linkage rod. Place the metal wheel collar and the throttle linkage spring onto the throttle rod (Do not tighten the wheel collar yet). Install the throttle servo horn onto the throttle servo as shown.

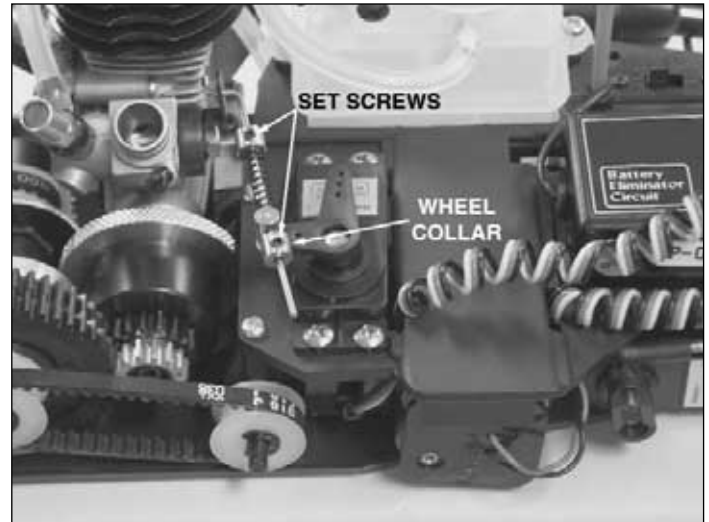

□ 17. Make sure the carburetor is at the idle setting (refer to the throttle stop screw, page 11), then install the second wheel collar onto the end of the throttle linkage rod. The wheel collar should slide up against the throttle linkage rod connector as shown.

□ 18. Slide the first wheel collar against the throttle linkage spring, slightly compressing the spring. Tighten the set screw in the wheel collar. **You should apply a small amount of thread lock to the set screws in the wheel collars to prevent them from loosening during running.**

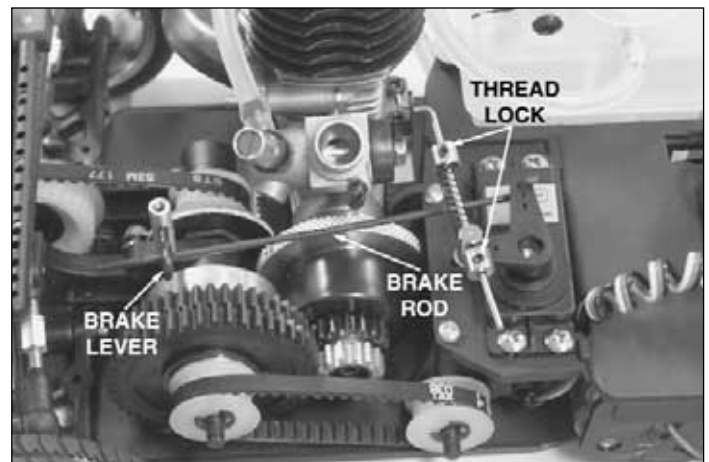

□ 19. Lift the throttle linkage servo horn off of the servo. Install the remaining z-bend wire from the bottom into the hole farthest from the center of the servo horn. **Note:** This hole is slightly enlarged. Slide the threaded end of the brake linkage rod through the brake lever.

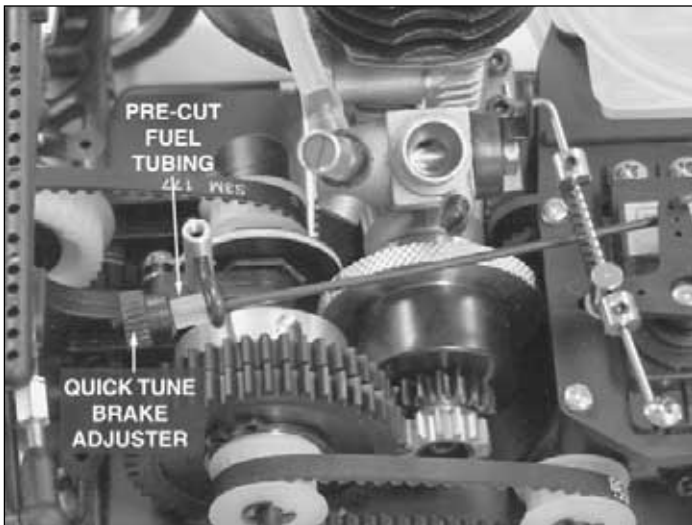

❑ 20. Slide the pre-cut 5mm (1/4") piece of fuel tubing onto the threaded end of the brake linkage rod. The fuel tubing should slide all the way up against the brake lever. Then thread the quick tune brake adjuster onto the brake linkage rod. Note: The transmitter should still be on for this step. Thread the quick tune brake adjuster on until it almost touches the pre-cut piece of fuel tubing. Note: At this position the car should roll freely. Move the transmitter trigger to apply the brakes and try to gently move the vehicle. If the car rolls freely the quick tune brake adjuster should be threaded on farther. If the car does not move then the linkage is set up correctly. Install the servo horn screw into the throttle servo.

## AIR FILTER INSTALLATION

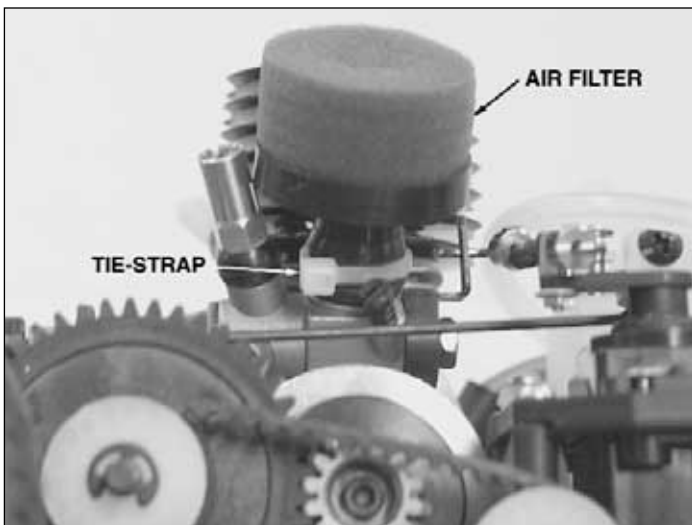

❑ 21. Install the air filter onto the carburetor. Using the included tie-strap, secure the air filter to the carburetor. Cut off any excess portion of the tie-strap to avoid interference.

## BODY MOUNTING

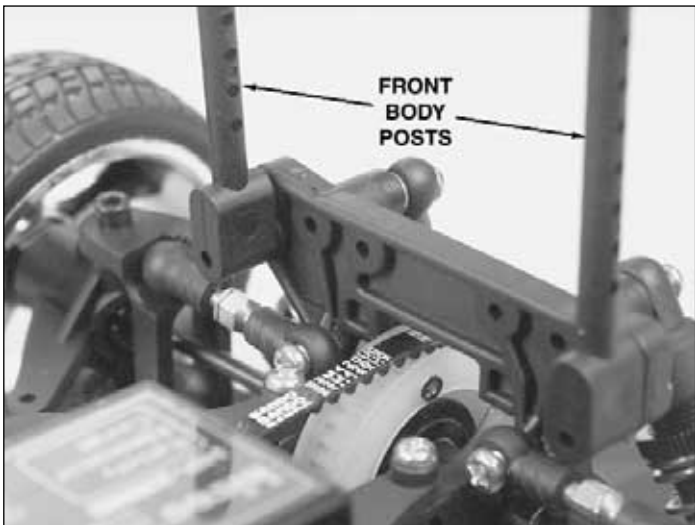
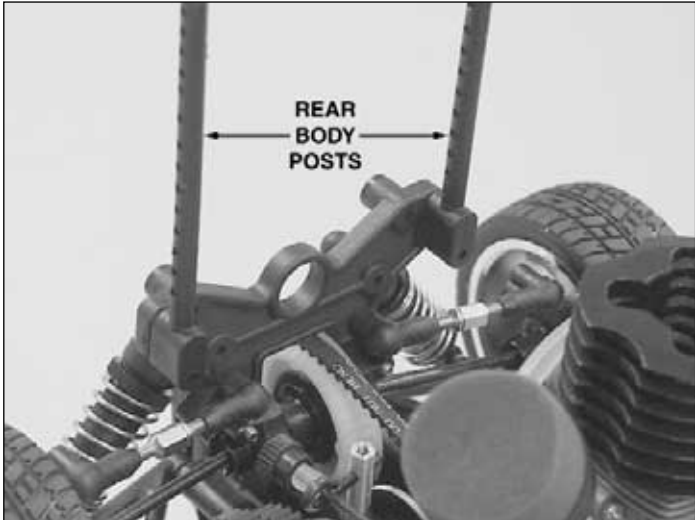

❑ 22. Raise the body posts to the upright position. Notice there is a molded pin that fits into a hole in the shock tower. This is to keep the body posts from swiveling during running. Tighten the screws in the body posts, making sure that the posts pull tight against the shock towers. You will have to remove the screws in the tops of the front shocks to get to the front body mount screws.

❑ 23. Remove the protective plastic from the outside of the body and apply the decals if desired.



BODY CLIP

❑ 24. Remove the body clips from the parts bag. On the front body posts place a body clip in the bottom hole of each post. On the rear body posts place a body clip in the third hole from the bottom in each post. Place the body onto the body mounts. On each body post place a body clip to secure the body onto the chassis. The excess body post can be trimmed off if desired.

## CARBURETOR SETTINGS

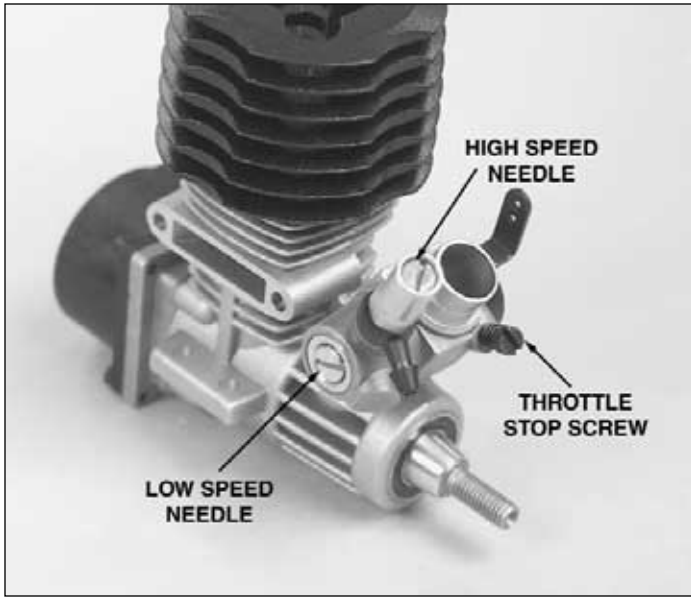

### The High-Speed Needle

The “high-speed” needle is sticking up from the side of the carb. It is located in the brass housing, just above the fuel inlet. It controls the fuel-to-air mixture of the carb. The needle is pre-set for break-in from the factory at 2-1/2 turns out from the fully closed position of the carb. Once the engine is broken-in, the high-speed needle would typically run from 2 to 2-1/2 turns out from closed, depending on the weather, humidity and altitude above sea level. To richen turn the needle counterclockwise, to lean turn the needle clockwise.

### The Low-Speed Needle

The “low-speed” needle is the screw in the carb body, opposite the throttle arm. It controls the fuel to air mixture at low throttle settings. There is a simple way of adjusting the low-speed needle correctly called the “pinch test.” With the engine at idle, pinch the fuel line and listen to how the engine speeds up or slows down. If the engine increases its speed for about 2 or 3 seconds and then loses RPM, the needle is set correctly. If the engine loses RPM quickly, it is set too lean and the low-speed needle needs to be opened (**counterclockwise**) to richen the mixture. Pinch again to check the mixture. If the engine takes longer than 4 seconds to slow down, lean (**clockwise**) the low-speed needle and then pinch again to check the mixture.

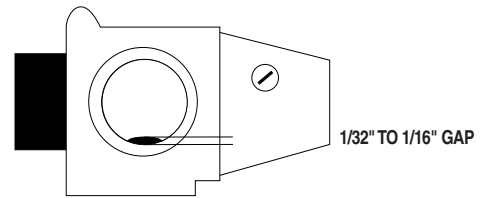

### The Throttle Stop Screw

On the front of the carburetor, there is a black screw. This is called the throttle stop screw. This increases or decreases the idle RPM without changing the fuel-to-air-mixture. You should see an opening of approximately 1.5mm (between 1/32” and 1/16”) between the carb body and the carb barrel when the throttle is pushed closed.

## RUNNING THE ENGINE

Before running the engine, read everything in this manual concerning engines and watch the engine video that came with this kit.

### There are several simple steps to starting the engine:

1. Install a glow plug if one is not in your engine. This threads into the top of the cylinder head.
2. Fill the tank almost to the top. Leave a little air at the top of the tank.
3. Prime the engine by turning the flywheel on the engine. Watch the fuel go through the line and when it gets to the carburetor, turn the flywheel one more full revolution.
4. Open the high speed needle valve exactly 2-1/2 turns out (**counterclockwise**) from fully closed. Be careful not to overtighten the high speed needle. When you feel some resistance, stop turning the needle. **The high-speed needle is sticking up from the carburetor inside the brass housing.** All of the carburetor settings are adjusted with a flat bladed screwdriver. If you have previously run the touring car, keep the same needle valve setting that you used on your last run.
5. Start the engine by pulling the recoil - Use short, quick pulls. **DO NOT** pull the recoil starter’s string to the end. You only need 10 to 12 inches of pull to start the engine.

If the engine does not start after several pulls, sometimes it is helpful to start the engine at around half throttle. Have a friend pull back on the throttle some while you start the engine. This *may* be an indicator that the low speed needle setting needs to be adjusted. When the engine starts, immediately return the throttle to idle. If this is not done the engine can

over-rev and cause engine damage. **If the engine is difficult to turn over with the recoil starter, especially if it is brand new, loosen the glow plug a half turn before starting the engine. This allows some compression to escape, but the engine will still start. Make sure you tighten the glow plug after the engine starts.** If the recoil starter is still difficult to pull, the engine is flooded – there is too much fuel inside the engine. Remove the glow plug and air cleaner, then turn the engine upside down and pull the recoil 5 or 6 times. This will clear the engine of fuel, and you will notice the recoil pulls easier. Replace the glow plug and repeat the starting procedure.

### Fuels

Use fuels that are specially formulated for car and truck engines. DuraTrax Red Alert fuel is specially formulated for R/C car engines like the Velocity .15.

### How To Stop Your Engine

You may have been wondering how to stop the engine. All you have to do is pinch the fuel line that runs to the carburetor and from the bottom of the fuel tank. Pinching this will restrict the fuel flow and the engine will quit within a few seconds. You can also touch the flywheel with the tip of your shoe through the hole in the bottom of the chassis.

## BREAKING-IN THE ENGINE

To insure long life and good performance from your Velocity .15 engine, you **MUST** break-in the engine. The break-in period is critical for long life of the internal parts of the engine. This should be done over the first 5 or 6 tanks of fuel. Be sure to watch the engine tuning video that came with this kit.

### Some Things To Remember During Break-In:

1. Run with the body off. This will keep the engine cooler.
2. Keep the air cleaner on at ALL times.
3. Run on a smooth, hard surface. An empty parking lot is perfect.
4. Use the same fuel that you will use for normal running.
5. Resist the urge to accelerate and decelerate the touring car quickly.
6. Break-in puts stress on the glow plug and you can burn it out during break-in. Make sure you have an extra plug or two on hand.
7. Do NOT overheat the engine. You can check the head temperature by using one of the temperature gauges that are available.

### The First Tank

Your first tank of fuel should be running the touring car at a very rich high-speed needle valve setting. This allows the fuel to carry as much oil as possible into the engine to lubricate the internal parts during the break-in.

1. Open the needle valve 2-1/2 turns from fully closed (counterclockwise). This is factory set already, but check it to make sure. When closing the high-speed needle, close the needle until you feel some resistance. **DO NOT** overtighten or you will damage the engine.
2. Start the engine.
3. Once the engine is started, open the high-speed needle valve around 1/8 turn at a time, finding the setting where the engine just barely runs. This may take a few times adjusting the needle, running the touring car away from you and back, then adjusting the needle. The touring car will perform sluggishly and stall from time to time - that is normal.
4. Run the touring car back and forth at medium speeds, slowly accelerating and decelerating the touring car, until the tank is almost out of fuel. Do not allow the tank to run out of fuel. This leans out the engine and can cause overheating.
5. Stop the engine and allow the engine to cool before the second tank. This normally takes around 10 minutes (See **How To Stop Your Engine**).

### Tanks 2-6

Turn in the needle valve (clockwise) around 1/12 turn from the previous setting. Run the touring car back and forth. You should notice that the touring car will perform better during each run. Stop the touring car periodically to check for overheating. If it is too hot, stop the engine. Wait for it to cool, then open up the needle valve and restart. After the 6th tank, you should be near to the peak performance of the engine.

## ENGINE MAINTENANCE

### Ten Ways To Ensure A Long Life From Your Engine:

1. Keep your engine clean. Dirt will act as insulation on an engine. It will not be able to shed heat as easily. Use a good air filter to keep dirt out of your engine and clean it often.
2. Do not over-lean your engine.
3. Do not run your engine with little or no load. Don't throttle up the engine to full throttle when the wheels are not in contact with the ground.

4. Do not overheat the engine. This goes along with keeping it clean and not over-leaning the engine.
5. Do not use a fuel with a low oil content. Make sure you use a fuel from a reputable manufacturer, such as DuraTrax Red Alert.
6. Avoid using old fuels in the engine. Always run all of the fuel out of the engine. After running for the day, use an after-run oil and work it into the engine by turning the flywheel or pulling the engine recoil slowly.
7. Do not use a fuel with a nitromethane (often called nitro) content over 20%.
8. Do not scratch the piston or cylinder sleeve. Avoid jamming something into the exhaust port when removing or re-installing the clutch or flywheel. Use a special tool called a crankshaft locking tool, which is installed in the glow plug hole.
9. Do not use silicone sealer on the engine joints. Silicone sealer contains acetic acid, which is corrosive if it gets inside your engine.
10. Do not allow any water inside the engine. This sounds easy, but temperature changes can cause condensation inside the engine. This is a good reason to use an after-run oil. Store your engine inside the house, not in a garage or shed where there will be temperature extremes.

***If you are having problems with your engine consult the engine troubleshooting flow chart on page 19. The following are some potential problems.***

### **Glow Plug**

The glow plug is an item that will wear out and need replacement from time to time. It is a good idea to remove the glow plug before your first run, heat it and see how well it glows. You should see a bright orange glow from the filament. If a coil or two will not glow or the plug will not glow at all, replace the plug. If the engine quits when you remove the glow starter, the plug might need to be changed, although this may be because you are running too rich and need to screw in your high-speed needle some. Look at the glow plug when you are running the engine. If you see some bubbles coming from around the plug, replace the glow plug (copper) gasket, or both the plug and gasket. The only real way to test a glow plug is to replace it. Make sure you have a spare plug or two on hand every time that you run the Street Force GP.

### **Fuel**

Fuel can go bad. The main ingredient in model fuel is methanol, which is basically an alcohol. Alcohols can absorb water out of the air, so keep your fuel jug capped at all times. Store your fuel out of the sunlight and in a cool place. Bad fuel is one of the most difficult problems to diagnose in engines. If you have tried everything you can think of to remedy an engine that is not running correctly, try using some fresh fuel.

Fuel line is susceptible to pinhole leaks. You cannot see the hole in the fuel line, but if you see air bubbles in the line going to the carburetor, replace the fuel line. Another symptom of a leak in the fuel line is a surging engine. The properly tuned engine will surge when the air bubbles hit the carb. It is basically leaning out the mixture.

To keep dirt out of the engine, use an inline fuel filter on the fuel line running from the fuel tank to the carburetor. Dirt can get caught in the needle seat and cause an inconsistent running engine. If you suspect that some dirt has lodged itself in the carb, remove the needles and clean the carb with denatured alcohol or fuel. It can help to use compressed air to blow out the fuel passages as well. Dirt can get into your carburetor and engine through the air filter. Ensure that your air cleaner has a good seal to the top of the carb. Periodically wash the air cleaner foam element and re-oil the filter. Any air cleaner that has a torn element or a bad seal should be replaced immediately.

### **Overheating**

One of the worst things you can do to your engine is overheat it. The oils that lubricate the engine are carried in the fuel. If your engine is set too lean, there will not be enough oil in the engine to lubricate the internal parts. This will cause premature wear in the engine and cause damage.

## **PERFORMANCE TUNING**

**Toe-In/Toe-Out:** This refers to the angle of the front tires when viewed from above when the suspension arms are level. If the fronts of the tires angle in, it is called "toe-in" and if the fronts of the tires angle out, it is called "toe-out." This is adjusted by lengthening or shortening the steering rods - the rods that run between the front hub and the servo saver. Normally a small amount of toe-in is used to make the touring car track straight at high speed. Too much toe-in will make the touring car difficult to turn as well as reduce the overall top speed because of tire scrub. Sometimes a small amount of toe-out will be used to help the steering. As a general rule use a small amount of toe-in.

## MAINTENANCE TIPS

### Before Each Run

- Check for loosened screws on the touring car. Engine vibration will loosen some of the screws, particularly in the engine mount area. Use thread lock on screws that thread into metal parts or use a metal nut.
- Inspect the air cleaner for a torn or damaged element. Also look for dirt in the air cleaner element and wash it if necessary.
- Check the suspension and drive train for binding.
- Inspect all of the wires for damage. Also check the connectors to make sure all of them are tight and in the proper place.
- Check the fuel tank and fuel lines for leaks.
- Before starting the engine, turn on the radio and make sure the servos move easily and in the right direction.
- Before running always check the condition of your radio system batteries and replace/recharge if necessary.

### After Each Run

- Drain the fuel tank of any leftover fuel. **DO NOT** return it to your fuel jug.
- Put some after-run oil in the carb and turn the flywheel several times to work the oil into the engine. This will protect the engine from rusting, especially when stored for a long period of time.
- Check again for loosened screws.
- **CLEAN** the touring car. Wipe off any oils that have collected on the chassis, engine end exhaust. Oils will attract dirt on the next run.

**Camber:** Camber is the angle of the tops of the tires when viewed from the front. Negative camber is when the tops of the tires are angled towards the center of the touring car. Positive camber is where the tops of the tires are angled away from the center of the touring car. Positive camber is very rarely used, if ever. A small amount of rear negative camber is helpful to increase traction in the rear. Negative camber at the front will increase stability. Camber adjustments can be made on the Street Force GP by turning the "camber rods," which are the upper links on the suspension. Lengthening the camber rod will add positive camber and shortening the camber rod will add negative camber.

**Shocks:** Changes in shock oils, springs, and pre-load on the springs can dramatically change the way the car handles. A thicker shock oil will make the touring car turn faster but reduces overall traction and handling over bumpy surfaces. Thinner oil will increase traction at the expense of steering response and the car will tend to roll more. In general, shock oils between 60 and 90 weight will be best for your touring car. You should experiment some to see what oils work best for your track and driving style. Shock springs affect the rate that the suspension rebounds from a bump. Pre-load on the springs means that the springs are already compressed some so that the suspension will rebound faster. Sometimes you will want to pre-load one side when the track has turns all or mostly in one direction, for instance an oval track. It will also increase the ride height.

Metric Conversions		1/4" =	6.4 mm	6" =	152.4 mm
1/64" =	.4 mm	3/8" =	9.5 mm	12" =	304.8 mm
1/32" =	.8 mm	1/2" =	12.7 mm	18" =	457.2 mm
1/16" =	1.6 mm	5/8" =	15.9 mm	21" =	533.4 mm
3/32" =	2.4 mm	3/4" =	19.0 mm	24" =	609.6 mm
1/8" =	3.2 mm	1" =	25.4 mm	30" =	762.0 mm
5/32" =	4.0 mm	2" =	50.8 mm	36" =	914.4 mm
3/16" =	4.8 mm	3" =	76.2 mm		

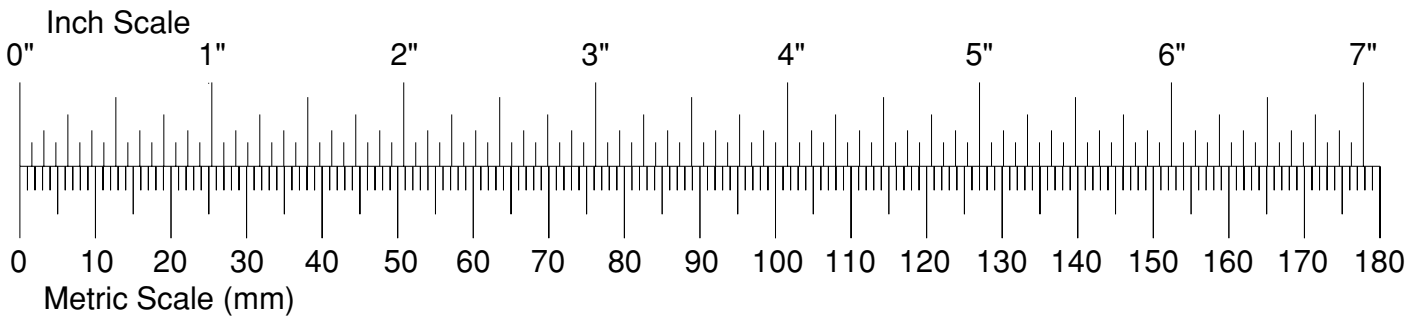

# ENGINE TROUBLESHOOTING

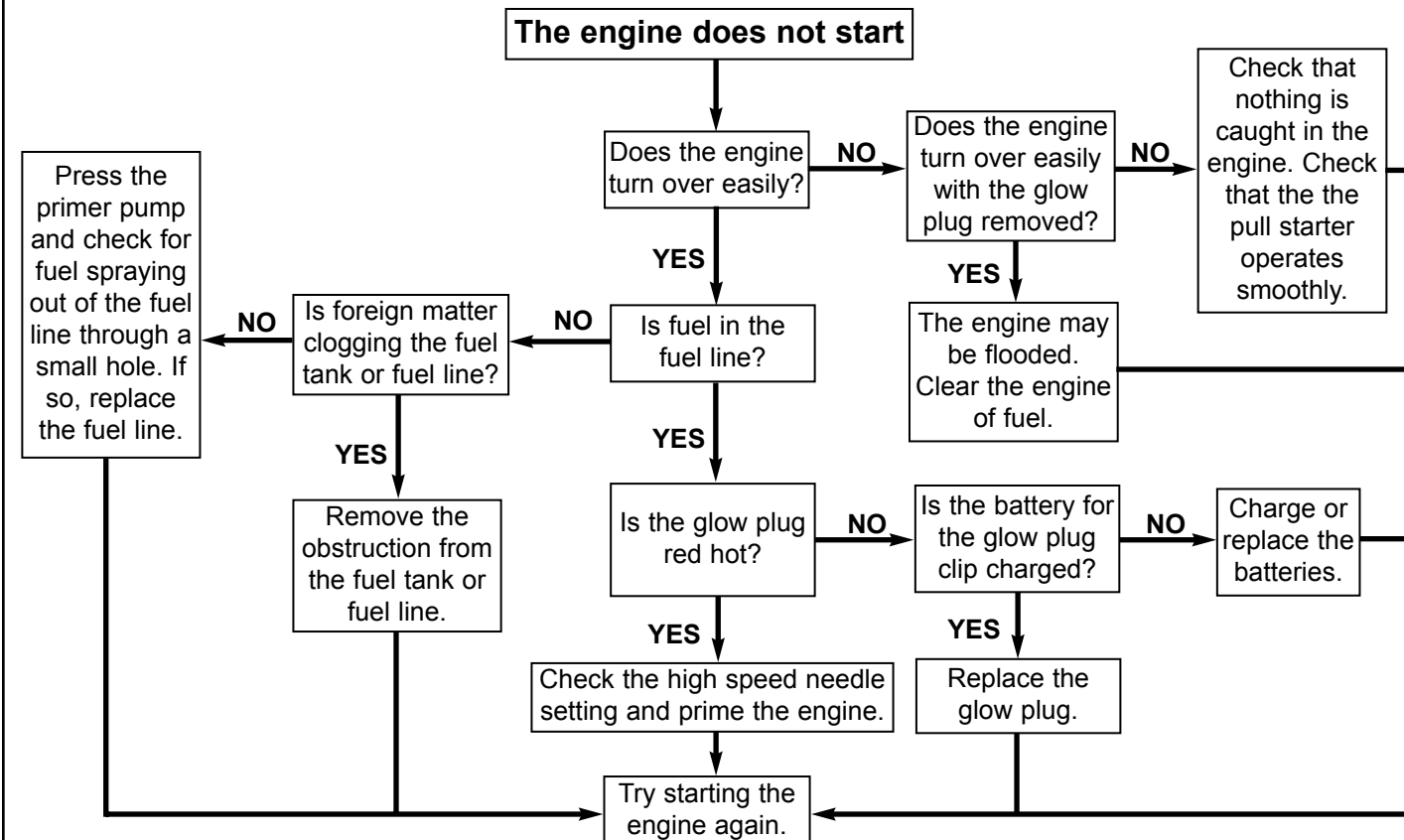
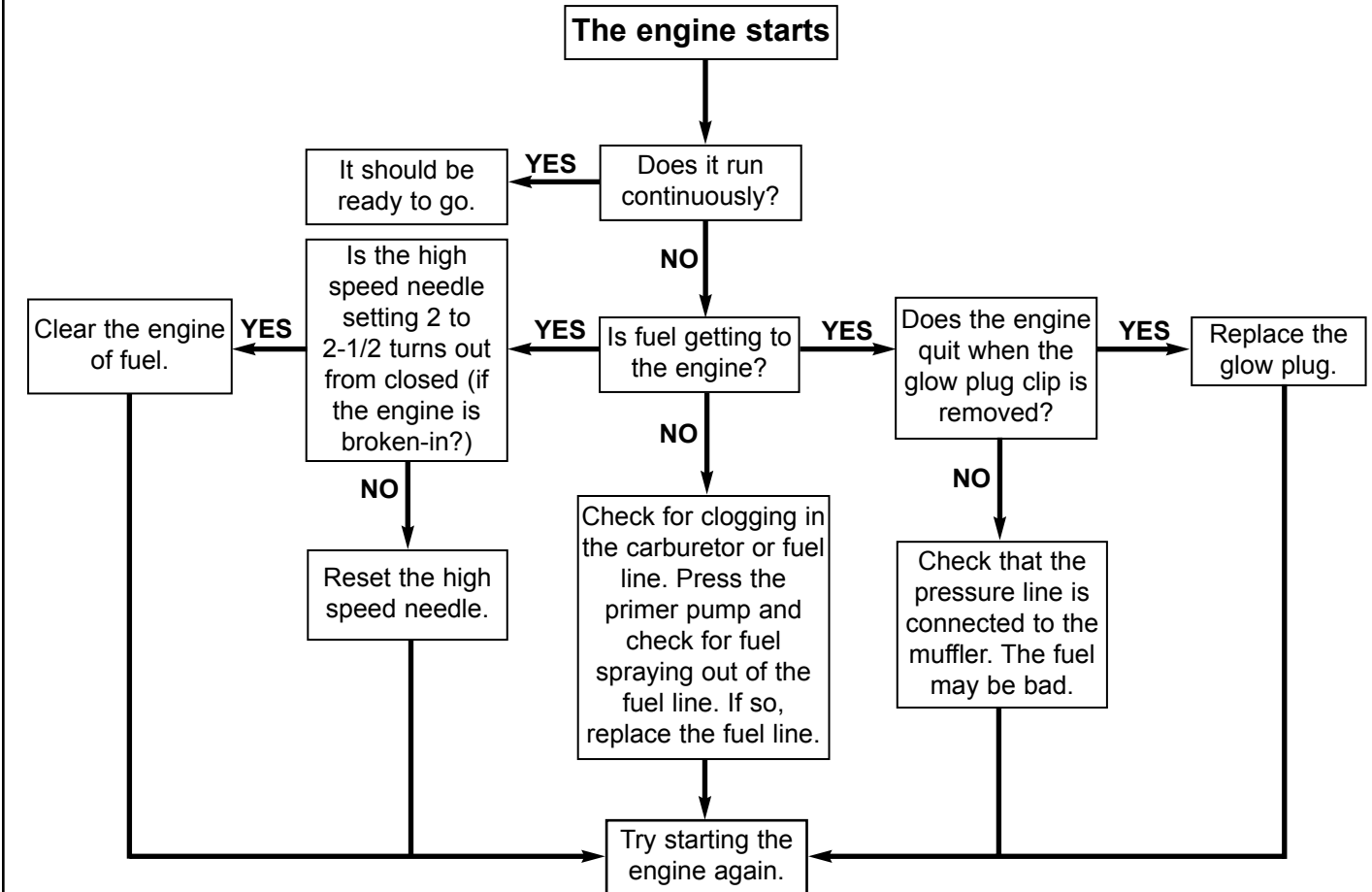

## ACCESSORIES AND OPTIONAL PARTS



### DuraTrax Nitro Starter Set

This set includes everything you need to start racing. 5-way glow plug wrench, 1 qt. of Red Alert fuel, Hobbico® glow starter w/charger, fuel bottle and glow plug. **DTXP0200**



### DuraTrax Crankshaft Locking Tool

Remove your engine's clutch safely with this easy to use, anodized metal tool. Works with all .10 to .21 car and buggy engines. **DTXR1100**



### DuraTrax Kwik-Pit™ 500cc Fuel Bottle

Fast, clean pit stops are as close as the Kwik-Pit Fuel Bottle. The long, angled neck reaches easily into your tank to prevent fuel spills, the clear plastic body keeps the fuel level in plain sight and moving fuel from the bottle to your tank takes just a gentle squeeze. **DTXP0150**



### DuraTrax Deluxe Glow Plug Wrench

This single, heavy-duty, plated steel tool handles FIVE metric hex sizes: 7-, 8-, 10-, 12- and 17mm—and includes a special 10mm socket for pilot shafts! Threaded holes tapped between the wrenches store up to four spare glow plugs. **DTXR1170**



### DuraTrax Red Alert™ 20% Racing Fuel

To make your TORQ™ 21 engine run faster, better and longer, you need the unique formula of DuraTrax Red Alert. Red Alert contains 20% nitro plus a carefully race-tested blend of castor and synthetic oils. **DTXP0600**



### DuraTrax XL Field Bag

Keep your gear loaded and race ready with the XL field bag. Heavy duty black nylon bag with red trim and white logo. **DTXP2000**

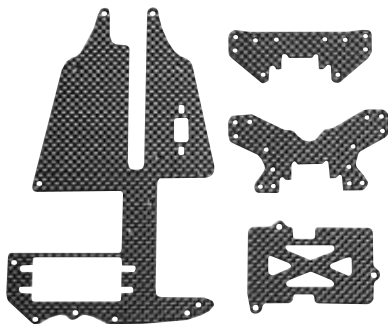

### Graphite Radio Tray and Shock Towers

Add graphite components for lighter weight and ultra high strength.

**DTXC8406 Graphite Radio Tray**  
**DTXC9196 Graphite Front Shock Tower**  
**DTXC9253 Graphite Rear Shock Tower**



### 3.25mm T-6 Aluminum Chassis

30% thicker than the stock chassis, and made from stronger, hard-anodized 7075 T6 aluminum for even greater flex-resistance than the original. **DTXC7026**

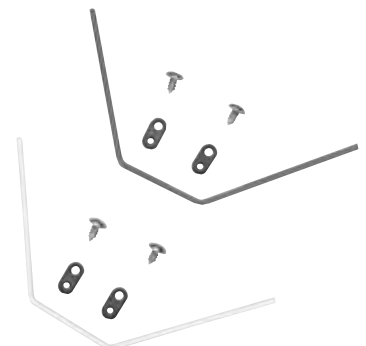

### Stabilizer Bar Kits

Will improve handling by limiting body roll in tight turns.

**DTXC9415 Stabilizer Bar Kit 1.8mm**  
**DTXC9416 Stabilizer Bar Kit 2mm**