

3PDF

Instruction Manual

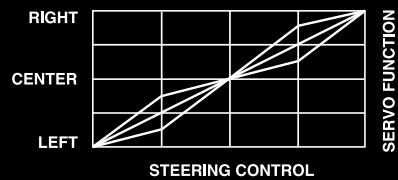

FM SUPER ELECTRIC DIGITAL TRIM

For Car's and Boat's
3 Channel Digital Proportional R/C System

1M23N02102

Thank you for purchasing the Futaba 3PDF.
Prior to operating your 3PDF, please read this manual thoroughly and use
your system in a safe manner.
After reading this manual store it in a safe place.

See the glossary on page (P36) for the definition's of the special terms used in
this manual.

Application, Export and Reconstruction

1. Use this product in surface models only.

The product described in this manual is subject to regulations of the Ministry of
Radio/Telecommunications and is restricted under Japanese law to such pur-
poses.

2. Exportation Precautions

(a) When this product is exported from Japan, its use is to be approved by the
Radio Law of the country of the destination.

(b) Use of this product with other than models may be restricted by Export and
Trade Control Regulations. An application for export approval must be submit-
ted.

3. Modification, adjustment and replacement of parts.

Futaba is not responsible for unauthorized modification, adjustment and re-
placement of parts of this product.

THE FOLLOWING STATEMENT APPLIES TO THE RECEIVER (FOR U.S.A.)

This device complies with part 15 of the FCC rules. Operation is subject to the
following two conditions.

- (1) This device may not cause harmful interference, and
- (2) This device must accept any interference received, including interference
that may cause undesired operation.

-No part of this manual may be reproduced in any form without prior permission.

-The contents of this manual are subject to change without prior notice.

-This manual has been carefully written, please write to Futaba if you feel that any corrections or clarifica-
tions should be made.

-Futaba is not responsible for the use of this product.

-Futaba is a registered trademark of Futaba Corporation.

For your safety as well as that of others.

Explanation of Symbols	2
Operation Precautions	2
Nicad Battery Handling Precautions	4
Other Precautions	4
Storage and Disposal Precautions	5

Prior to Operation

Features	6
Set Contents	7
Nomenclature / Handling	8
Digital Trim Operating Instructions	11
D/R ATL CH3 Lever Operating Instructions	11
Display / Key Operation	12
Warning Displays	13
Precautions when turning the power switches off and on.	13

Assembly

Receiver and Servo Connections	14
Assembly Safety Precautions	15
Preparations Prior to Setting Transmitter	16
E.S.C. MC210CB Adjustment	17

Function Map

Function Mode Group	18
System Mode Group	18
Direct Mode Group	19

Description of Functions

Steering Trim	20
Throttle Trim	21
Servo Reverse	22
Steering ATV	23
Throttle ATV	24
Steering D/R	25
Throttle ATL	26
Steering Exponential	27
Throttle Exponential	28
Model Select	29
Model Name	30
Lever Function Select	31
Channel 3 Function Selection	32
CH3 Position Setting	33

Reference

Ratings	34
Optional parts	34
Troubleshooting	35
Glossary	36
When requesting repair	37

For your safety as well as that of others.

Prior to Operation

Assembly

Function Map



Description of Functions

Reference

Use this product in a safe manner. Please observe the following safety precautions at all times.

Explanation of Symbols

The parts of this manual indicated by the following symbols are extremely important and must be observed.

Symbols	Explanation
 DANGER	Indicates a procedure which could lead to a dangerous situation and may cause death or serious injury if ignored and not performed properly.
 Warning	Indicates procedures which may lead to dangerous situations and could cause death or serious injury as well as superficial injury and physical damage.
 Caution	Indicates procedures that may not cause serious injury, but could lead to physical damage.

Symbols:



; Prohibited



; Mandatory

Operation Precautions

Warning

Prohibited Procedures

 Do not operate two or more models on the same frequency at the same time.

Operating two or more models at same time on the same frequency will cause interference and loss of control of both models.

AM, FM (PPM) and PCM are different methods of modulation. Nonetheless the same frequency can not be used at the same point in time, regardless of the signal format.

 Do not operate in the following places.

- Near other sites where other radio control activity may occur.
- Near people or roads.
- On any pond when rowboats are present.
- Near high tension power lines or communication broadcasting antennas.

Interference could cause loss of control . Improper installation of your Radio Control System in your model could result in serious injury.

 Do not operate outdoors on rainy days , run through puddles of water or when visibility is limited.

Should any type of moisture (water or snow) enter any component of the system, erratic operation and loss of control may occur.

 Do not operate this R/C system when you are tired, not feeling well or under the influence of alcohol or drugs.

Your judgment is impaired and could result in a dangerous situation that may cause serious injury to yourself as well as others.

Mandatory Procedures

- ! Extend the transmitter antenna to its full length.

If the transmitter antenna is not fully extended the operating range of the radio will be reduced.



- ! When changing the frequency, be sure to always use genuine Futaba crystal sets (transmitter and receiver) as specified in this manual. (Changing the frequency crystals in systems on 75MHz is illegal per FCC regulations)

If other brands of crystals are used the system may not operate or the operating range may be reduced. Loss of control will occur.

Use genuine Futaba crystal sets only.

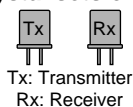

- ! Always perform a operating range check prior to use.

Problems with the radio control system as well as improper installation in a model could cause loss of control.

(Simple range test method)

Have a friend hold the model, or clamp it down or place it where the wheels or prop can not come in contact with any object. Walk away and check to see if the servos follow the movement of the controls on the transmitter. Should you notice any abnormal operation, Do not operate the model. Also check to be sure the model memory matches the model in use.

Item Check

- ! Check the transmitter antenna to be sure it is not loose.

If the transmitter antenna works loose, or is disconnected while the model is running signal transmission will be lost. This will cause you to lose control of the model..

Caution

Prohibited Procedures

- ⊘ Do not touch the engine, motor, speed control or any part of the model that will generate heat while the model is operating or immediately after its use.

These parts may be very hot and can cause serious burns.

Mandatory Procedures

- ! Turning on the power switches. Always check the throttle trigger on the transmitter to be sure it is at the neutral position.

1. Turn on the transmitter power switch.
2. Turn on the receiver or speed control power switch.

Turning off the power switches Always be sure the engine is not running or the motor is stopped.

1. Turn off the receiver or speed control power switch.
2. Then turn off the transmitter power switch.

If the power switches are turned off in the opposite order the model may unexpectedly run out of control and cause a very dangerous situation.

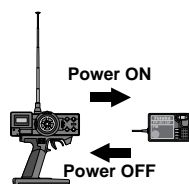

- ! When making adjustments to the model do so with the engine not running or the motor disconnected.

You may unexpectedly lose control and create a dangerous situation.

- ! When operating your model always display a frequency flag on your transmitter antenna.

When you change the frequency, also change the flag to the corresponding channel.

Nicad Battery Handling Precautions

(Only when Nicad batteries are used)

⚠ Warning

Mandatory Procedures

! Always check to be sure your batteries have been charged prior to operating the model.

Should the battery go dead while the model is operating loss of control will occur and create a very dangerous situation.

! When the model is not being used, always remove or disconnect the Nicad battery .

Should the battery be left connected this could create a dangerous situation if someone accidentally turns on the receiver power switch. Loss of control would occur.

! To recharge the transmitter Nicad , use the special charger made for this purpose.

Overcharging could cause the Nicad battery to overheat, leak or explode. This may lead to fire, burns, loss of sight and many other type's of injuries.



Special Charger

⚠ Caution

Prohibited Items

⊘ Do not use commercial AA size Nicad batteries.

Quick charging may cause the battery contacts to overheat and damage the battery holder.

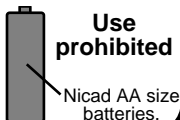

⊘ Do not drop the Nicad battery or expose it to strong shocks or vibrations.

The battery may short circuit and overheat, electrolyte may leak out and cause burns or chemical damage.



⊘ Do not short circuit the Nicad battery terminals.

Causing a short circuit across the battery terminals may cause abnormal heating, fire and burns.

Other Precautions

⚠ Caution

— Prohibited Procedures —

⊘ Do not expose plastic parts to fuel, motor spray, waste oil or exhaust.

The fuel, motor spray, waste oil and exhaust will penetrate and damage the plastic.

— Mandatory Procedures —

! Always use only genuine Futaba transmitters, receivers, servos, FET amps (electronic speed controls), Nicad batteries and other optional accessories.

Futaba will not be responsible for problems caused by the use of other than Futaba genuine parts. Use the parts specified in the instruction manual and catalog.

Storage and Disposal Precautions

Warning

— Prohibited Procedures —

-  Do not leave the radio system or models within the reach of small children.

A small child may accidentally operate the system, this could cause a dangerous situation and injuries. Nicad batteries can be very dangerous when mis-handled and cause chemical damage.

-  Do not throw Nicad batteries into a fire. Do not expose Nicad batteries to extreme heat. Also do not disassemble or modify a Nicad battery pack.

Overheating and breakage will cause the electrolyte to leak from the cells and cause skin burns, loss of sight as well as other injuries.

— Mandatory Procedures —

-  When the system will not be used for any length of time store the system with batteries in a discharged state. Be sure to recharge the batteries prior to the next time the system is used.

If the batteries are repeatedly recharged in a slightly discharged state the memory effect of the nicad battery may considerably reduce the capacity. A reduction in operating time will occur even when the batteries are charged for the recommended time.

<Nicad Battery Electrolyte>

The electrolyte in Nicad batteries is a strong alkali. Should you get even the smallest amount of the electrolyte in your eyes, DO NOT RUB, wash immediately with water, seek medical attention at once. The electrolyte can cause blindness. If electrolyte comes in contact with your skin or clothes, wash with water immediately.

Caution

— Prohibited Procedures —

-  Do not store your R/C system in the following places.
 - Where it is extremely hot or cold.
 - Where the system will be exposed to direct sunlight.
 - Where the humidity is high.
 - Where vibration is prevalent.
 - Where dust is prevalent.
 - Where the system would be exposed to steam and condensation.

Storing your R/C system under adverse conditions could cause deformation and numerous problems with operation.

— Mandatory Procedure —

-  If the system will not be used for a long period of time remove the batteries from the transmitter and model and store in a cool dry place.

If the batteries are left in the transmitter electrolyte may leak and damage the transmitter. This applies to the model also, remove the batteries from it also to prevent damage.

<Nicad Battery Recycling>

A used Nicad battery is valuable resource. Insulate the battery terminals and dispose the battery by taking it to a battery recycling center.

For your safety as well as that of others.

Features

-Multiple Model Memory (3 Models)

A model name can be assigned each memory using six alphabetic, numeric and symbolic characters. (P30)

Digital Trim Memory will recall all trim settings. As you go from model to model memory all trim settings will not have to be reset.

-Large LCD Display

All program information is displayed on a 8 character 2 line display. The large display is easy to read.

-The third channel can be used to match your application in specialty models.

The third channel can be used in five operation modes.(P32)

-Digital Trim

Digital trim will allow positive and quick settings to be made.

-Lever Function Selection (P31)

This function applies to D/R, ATL and 3rd channel levers.. Since they are digital, when you change the model memory these will not require you to readjust the settings . They will be where they were the last time that model memory was used.

-New Lightweight and Balanced Design

-Trigger Brake Stop (Mechanical ATL) (P8)

-Body Rest can be used (Option)

-Servo Reverse Function (P22) / Steering ATV Function (P23) / Steering D/R function (P25) / Throttle ATV Function (P24) / Throttle ATL Function (P26)

Set Contents

After opening the container, check the contents for the following items. The contents will vary with the system purchased.

	Transmitter / Receiver	System with 2 servos	System with 1 MC210CB
Transmitter	T3PDF (x1)		
Receiver	R113F (x1)		
Servo		S3003 (x2)	S3003 (x1)
E.S.C.			MC210CB (x1)
Switch		CSW-GS (x1) or (none)	
Battery Holder		R2-BSS-B (x1) or (none)	
Miscellaneous		Servo mounting hardware and servo horns	Mini Screwdriver

-Should any item be missing or you are uncertain of the contents of the system, please contact the dealer where the system was purchased.

Nomenclature / Handling

Transmitter T3PDF (Front)

Prior to operation

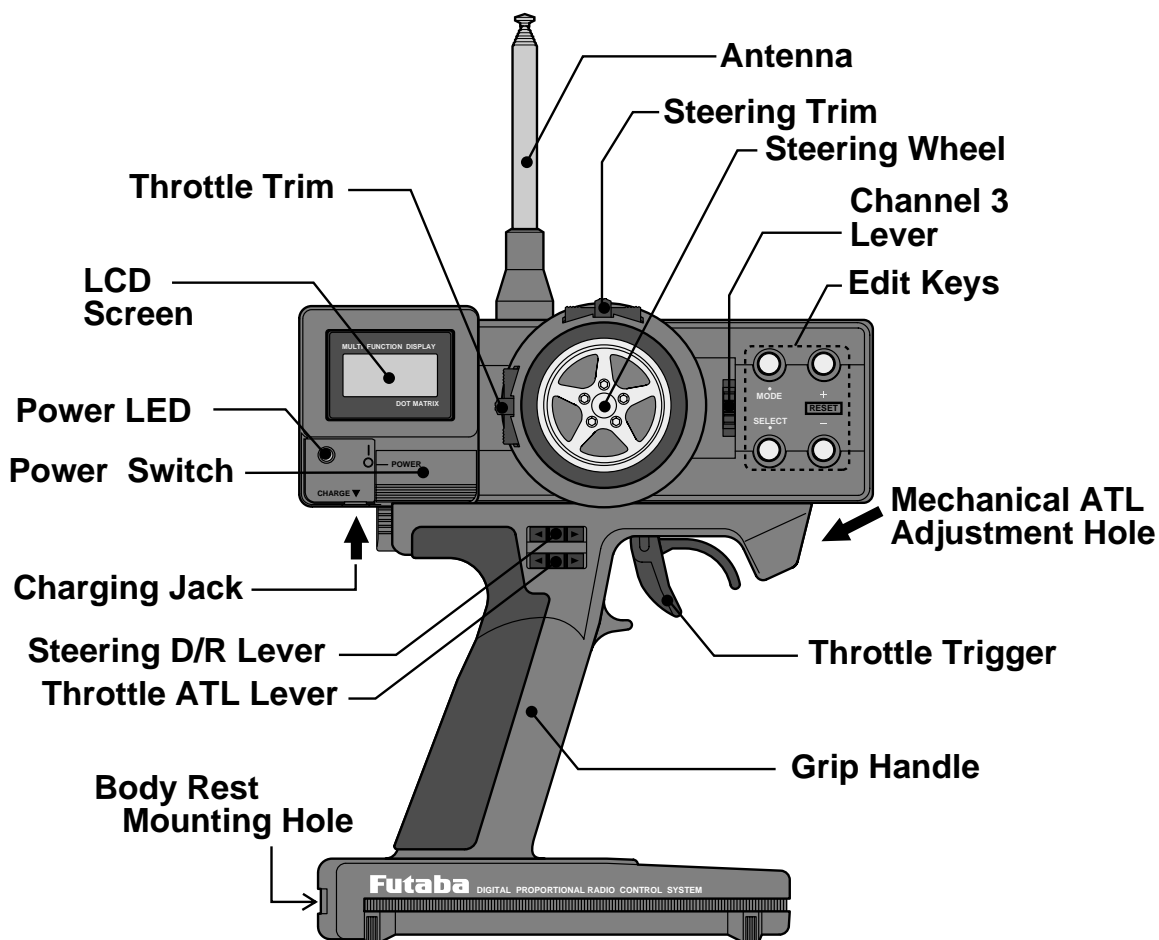

* In the figure above the levers are shown in the neutral position.

Charging Jack

This jack is used to charge Nicad battery when used.

⚠ Caution

⊘ Never charge a dry cell type (Non-Nicad) battery.

Charging a non nicad type battery may damage the transmitter, and could cause the battery electrolyte to leak and cause additional damage.

Mechanical ATL

The throttle trigger travel can be adjusted to limit the brake stroke.

-Adjustment Method

When the screw is turned clockwise the brake stroke will become shorter.

When the screw is turned counter clockwise the stroke becomes longer as shown in the figure above.

Transmitter T3PDF (Rear)

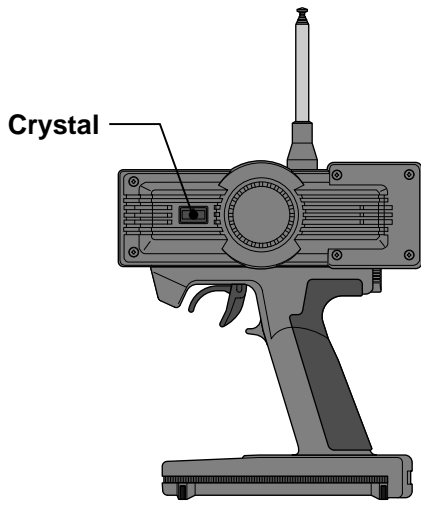

Transmitter T3PDF (Bottom)

Handling the batteries (8 AA size batteries)

Battery Replacement

- 1 Open the battery cover by sliding in the direction of the arrow shown in the figure.
- 2 Remove used batteries.
- 3 Load the new AA size batteries. Pay very close attention to the polarity markings and reinsert accordingly.
- 4 Slide the battery cover back into place.

<Check>

Turn the power switch on and check voltage displayed on the LCD screen. With new batteries the voltage displayed should be around 12 volts. If the displayed voltage is low or does not light all, check the batteries for insufficient contact or incorrect battery polarity.

When the battery alarm sounds change the batteries, or if Nicads are used recharge.

(Alarm voltage: approx. 8.7 Volts)

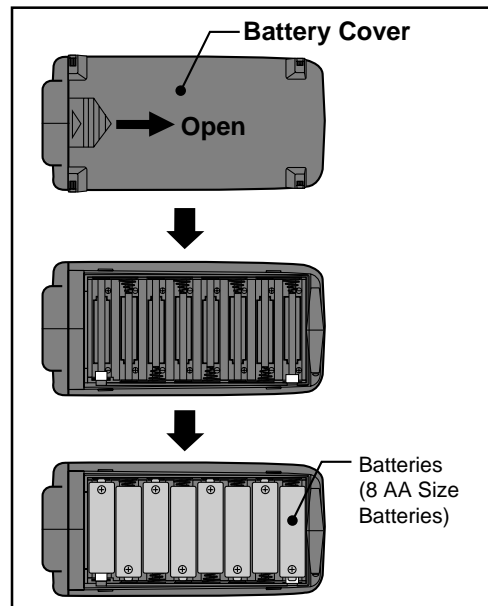

⚠ Caution

❗ Be sure to load the batteries in the correct polarity order.

If the polarity is reversed the transmitter may be damaged.

❗ When the system will not be used for any length of time remove the batteries.

If the batteries do happen to leak, clean the battery contacts thoroughly. Make sure the contacts are free of corrosion.

<Battery Disposal>

Some states require special handling when any type of battery is disposed. Contact the State Agency responsible for recycling hazardous waste for procedures in your area.

<Converting to Nicad Batteries>

Purchase Futaba Part Number NT-8JY to convert your transmitter to Nicad use.

Receiver R113F

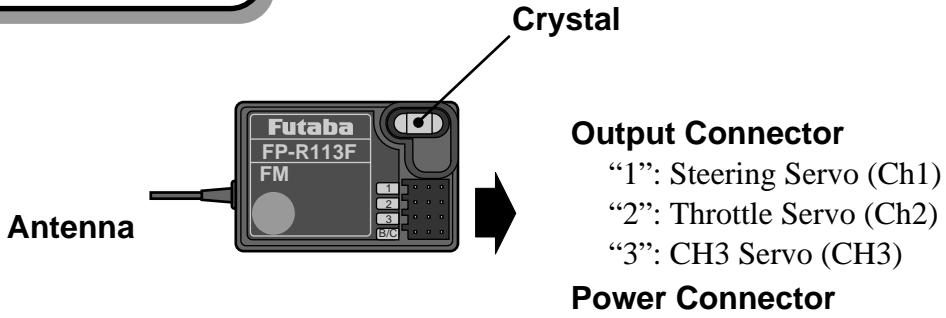

Servo S3003

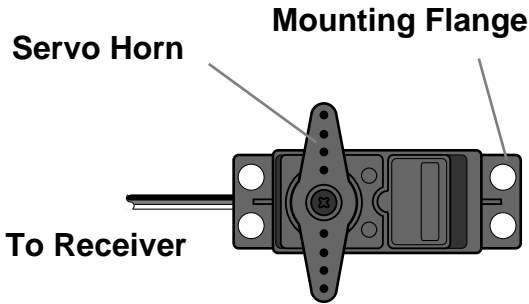

<Accessories>

The following accessories are supplied with the system;

- Spare servo horns: Use to match your application.
- Servo mounting hardware: Rubber bushing, grommet, wood screws.

(For mounting precautions see pages 15.)

Electronic speed control MC210CB

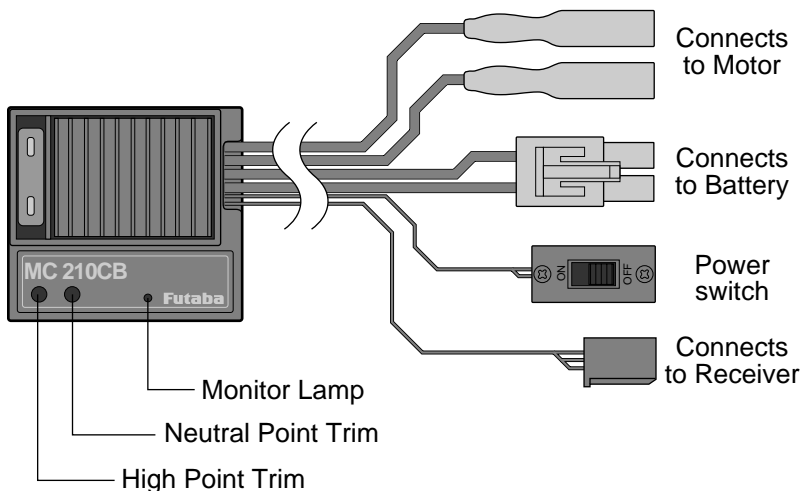

Digital Trim Operating Instructions

To operate the digital trim push the trim lever to the left or right.

- A “Tone” will indicate each step.
- When the trim movement reaches its maximum travel the “tone” will change pitch.
- When a trim lever is moved the current trim position will be displayed on the LCD screen.

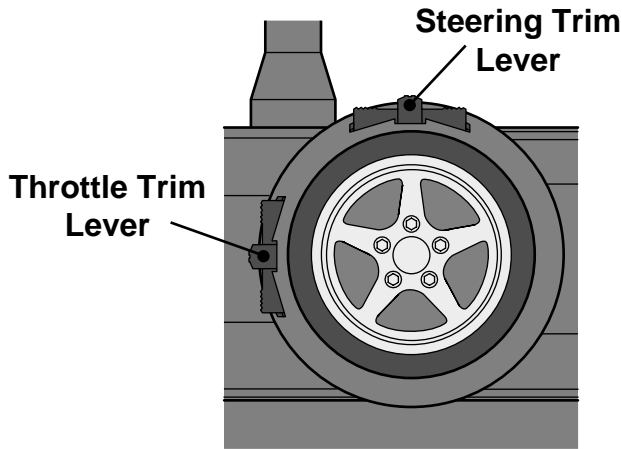

Prior to operation

D/R ATL CH3 Lever Operating Instructions

Operate the levers by pushing them to the left or right (up or down).

- A “Tone” will indicate each step.
- When a lever reaches its maximum travel the pitch of tone will change.
- When a lever is moved its current position will be displayed on the LCD screen.

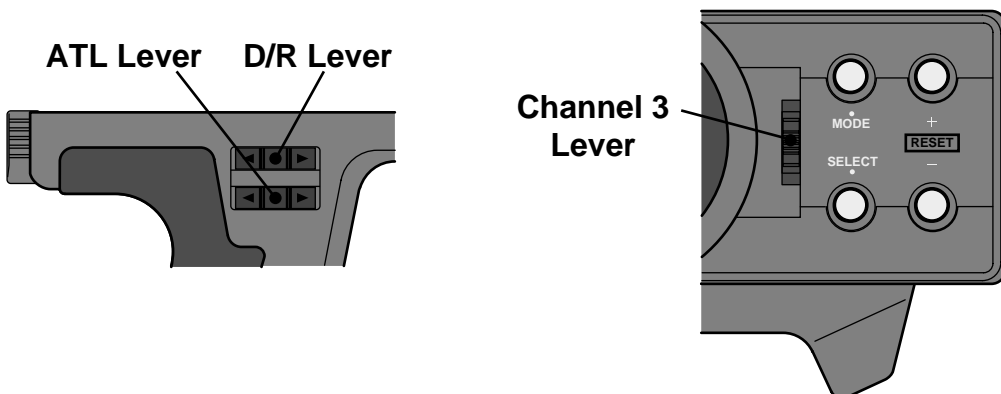

Display / Key Operation

Initial Screen (Normal Screen)

Model Number Display (1~3)

Displays the number currently in use.

Model name display (only when set) (6 characters)



Battery voltage display

Displays the current transmitter battery voltage level.

LCD screen contrast adjustment

- 1 Turn on the transmitter power switch , the screen will show the current settings.
- 2 Adjust the Contrast by pressing the + or - key while pressing the Select key at the same time.
 - The Contrast can be adjusted in 4 steps.
 - + key: darker
 - key: Lighter

Edit Keys

Mode Key

Used to select the function

Select Key

Used to select the channel, etc. at the function screen.

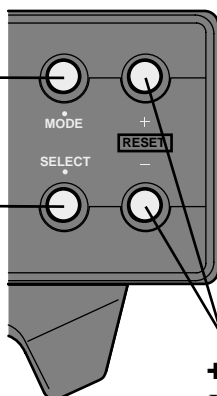

+ Key / - Key

Used to input data at the function screen.

Warning Displays

Low Battery Warning

When the transmitter battery voltage drops to 8.7 volts or less. A audible alarm will sound and the message “Low Batt” will appear on the display screen. Replace or recharge the batteries when you hear this alarm.

LCD Screen:



Audible Alarm:

Continuous Tone will sound.

Warning

 When the low battery alarm is heard, immediately stop operating the model. Retrieve the model and turn off the power switches in the proper order (Receiver then Transmitter).

A discharged battery will no longer operate the transmitter and cause loss of control.

Memory Error

If the data is destroyed for any reason an audible alarm will sound. The message “MEMORY ERROR” will appear on the display screen as a warning.

LCD Screen:



Audible Alarm:

Continuous Tone will sound.

Warning

 When a memory error is generated immediately stop operating the system and request repair by the Futaba service center.

If you continue to operate the system control may be erratic and cause of control is highly likely.

Precautions when turning the power switches off and on.

If the power switches are turned off within 2 seconds after the data has been changed by using the edit keys or trim levers. The information may not be retained by the memory.

Receiver and Servo Connections

Connect and install the receiver and servos in accordance with the "Assembly Safety Precautions" on the next page.

When a E.S.C. is used (MC210CB)

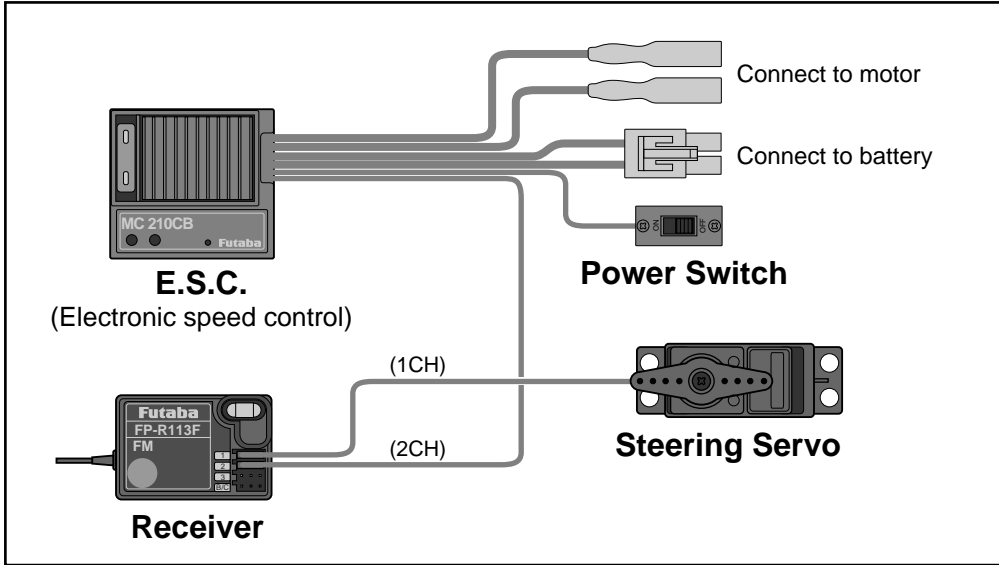

Gas Powered Model

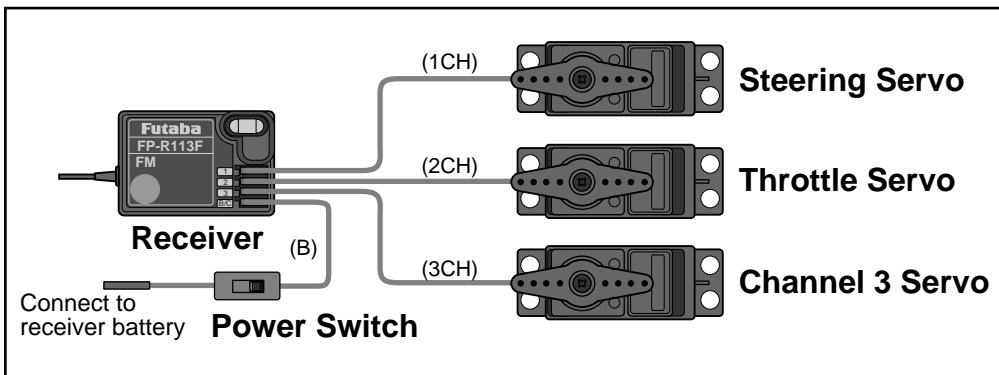

Assembly Safety Precautions

Warning

Connector Connections

-  Be sure the receiver, servo and battery connectors are fully and firmly connected.

If vibration from the model cause a connector to work loose while the model is in operation. You may lose control .

Receiver Vibration Damping and Waterproofing

(Car)



-  Dampen the vibration to the receiver by mounting to the chassis or mounting plate with thick double sided tape in electric powered models. In gas powered models wrap the receiver in foam and mount it where the vibration is the least prevalent.

(Boat)

-  Dampen the vibration to the receiver by wrapping it in foam. Waterproof by placing it in plastic bag or watertight radio box in model.

If the receiver is subjected to strong vibration or shock erratic or loss of control may occur. If any moisture comes in contact the receiver and servos you may expertise the same result as well as damage to the system.

Receiver Antenna

-  Do not cut or bundle the receiver antenna
-  Do not bundle the receiver antenna together with the servo lead wires
-  Keep the receiver antenna at least 1 inch away from the motor and battery and wires that handle heavy current loads..

Cutting, bundling or routing the receiver antenna near any devise that produce noise will reduce the operating range of the system and result in loss of control.

*Also route the receiver antenna away from metal, carbon fiber and other parts that conduct electricity. These parts can transmit high frequency noise.

Electronic speed control

-  Install the heat sinks where they will not come in contact with aluminum, carbon fiber or other parts that conduct electricity.

If the FET Amp (Electronic speed control) heat sinks touch other materials that conduct electricity a short circuit could occur. This could result in loss of control and damage to the system.

Servo Throw

-  Operate each servo over its full stroke and be sure the linkage does not bind or is loose.

The continuous application of unreasonable force to a servo may cause damage and excessive battery drain.

Servo Installation

-  When you install the servos always use the rubber grommets provided in servo hardware bags. Mount the servos so they do not directly come in contact with the mount.

If the servo case comes in direct contact with the mount vibration will be directly transmitted to the servo.

If this condition continues for a long time the servo may be damaged and control will be lost.

Motor Noise Suppression

-  Always install capacitors to suppress noise when electric motors are used.

If capacitors are not properly installed you could experience erratic operation and reduced range as well as loss of control.

Other Noise Suppression Methods

-  Be sure there are no metal parts in your model which under vibration can come in contact with other metal parts.

Metal to metal contacts under vibration will omit a high frequency noise that will effect the receivers performance. You could experience erratic operation and reduced range as well as loss of control.

Preparations Prior to Setting Transmitter

Prior to making any setting on the transmitter check the following items.

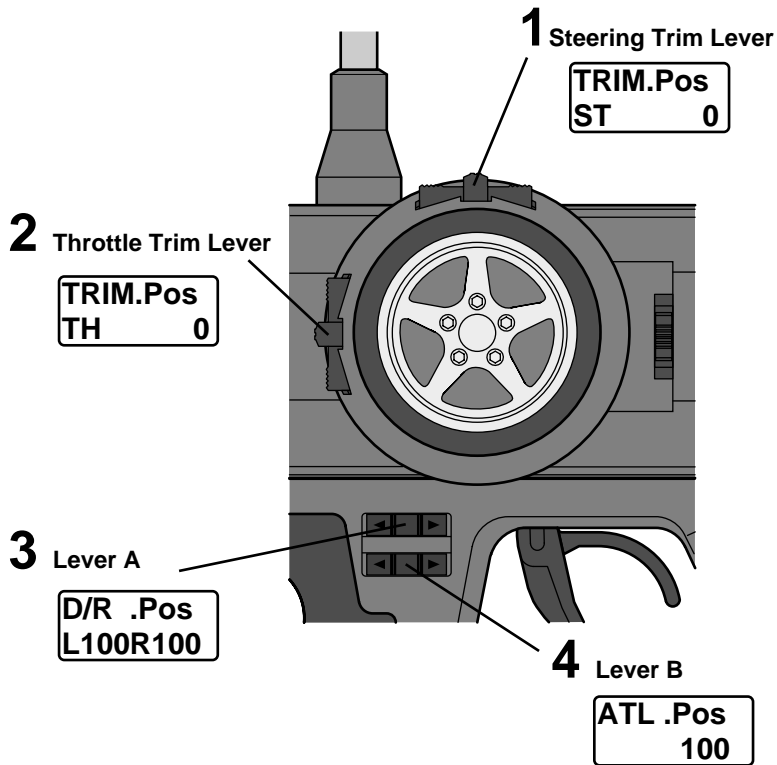

Preparations Prior to Setting Transmitter

- 1** To set the steering trim to neutral, push the channel 1 trim lever to the left or right. The display will read TRIM.Pos. Hold the lever to the left or right until you set 0 on the display. This will be the neutral position.
- 2** To set the throttle trim to neutral, push the channel 2 trim lever up or down. The display will read TRIM.Pos. Hold the lever up or down until you see 0 on the display. This will be the neutral position..
- 3** To set Grip Dial A to maximum, push the upper lever to the left or right. The display will read GDA. Hold the lever to the right or left. The maximum setting will be L100 R100.
- 4** To set Grip Dial B to maximum, push the lower lever to the left or right. The display will read GDB.Pos ATL. Hold the lever to the left or right. The maximum setting will be 100.

E.S.C. MC210CB Adjustment

*Use the accessory mini screwdriver to make adjustments.

Preparation

- 1 Set the transmitter servo reversing switch to the normal position.
- 2 Turn the high point trim fully clockwise.

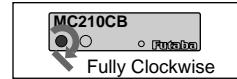

Neutral Adjustment

- 1 Have the throttle trigger at neutral.
- 2 Set the neutral trim to the point where the monitor lamp goes off.
 - The point where the monitor lamp changes from a rapidly flashing light to off is the neutral point.

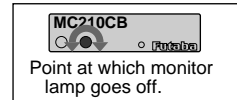

High Point Adjustment

- 1 Set the throttle trigger to just a little before full throttle.
- 2 Set the high point trim to the point where the monitor lamp is a steady light.
 - The point where the monitor lamp changes from a rapidly flashing to a steady light is full throttle.

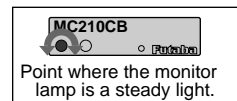

Monitor Lamp

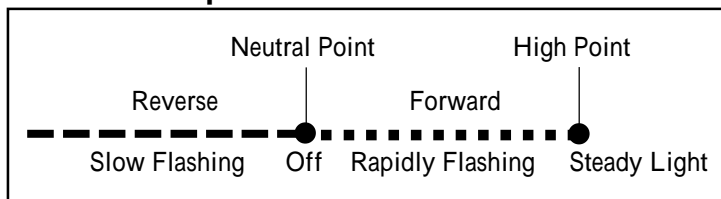

When the Mode key is pressed from the initial screen where the voltage is displayed, this will call the FUNCTION MODE.

When the MODE key and the SELECT key are pressed simultaneously at the initial screen., this will call the SYSTEM MODE.

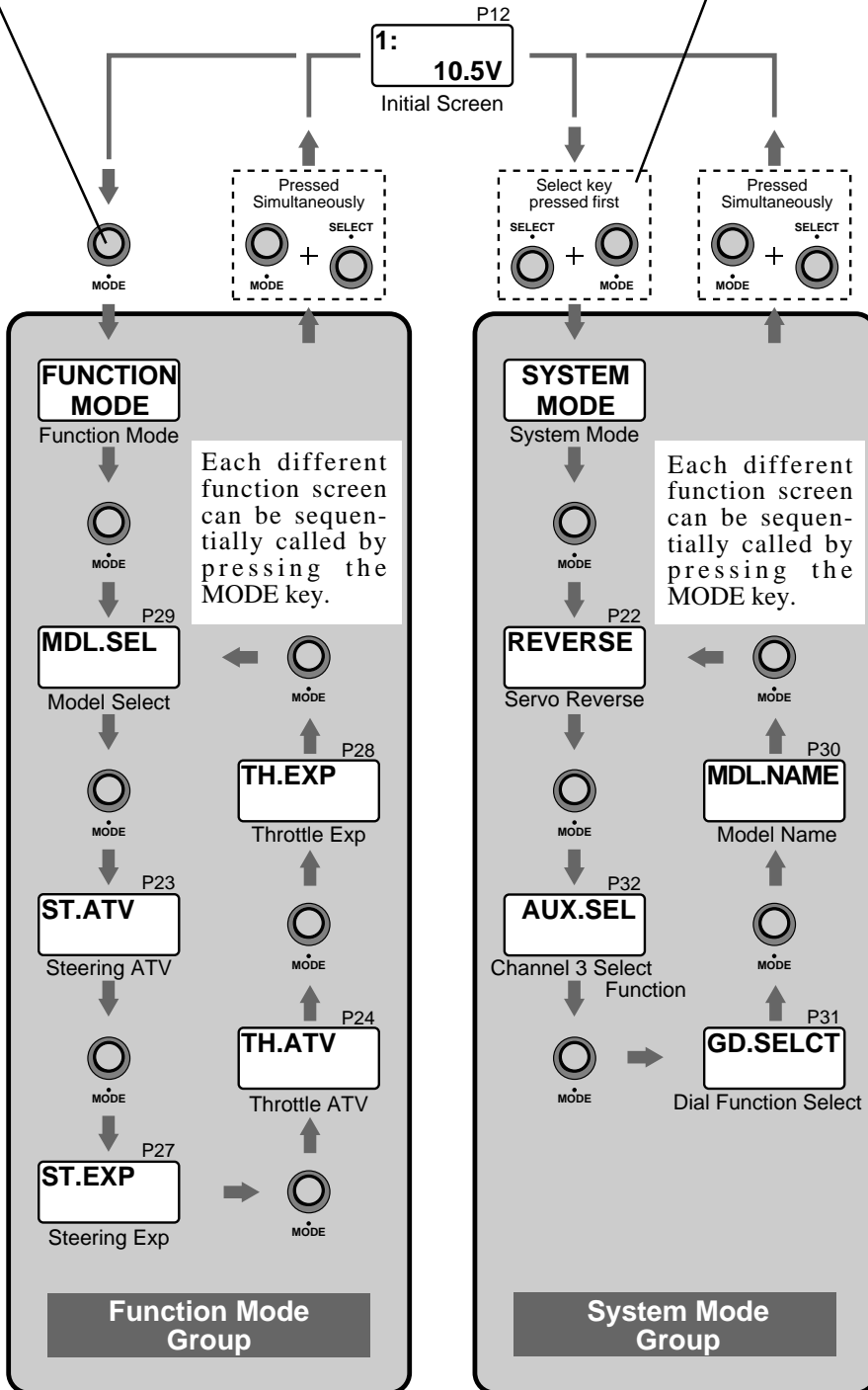

When a lever is operated from an arbitrary screen, that screen is displayed for about 5 seconds.

* However, when the system mode setup screen is displayed, the direct mode screen is not displayed even if a lever is operated.

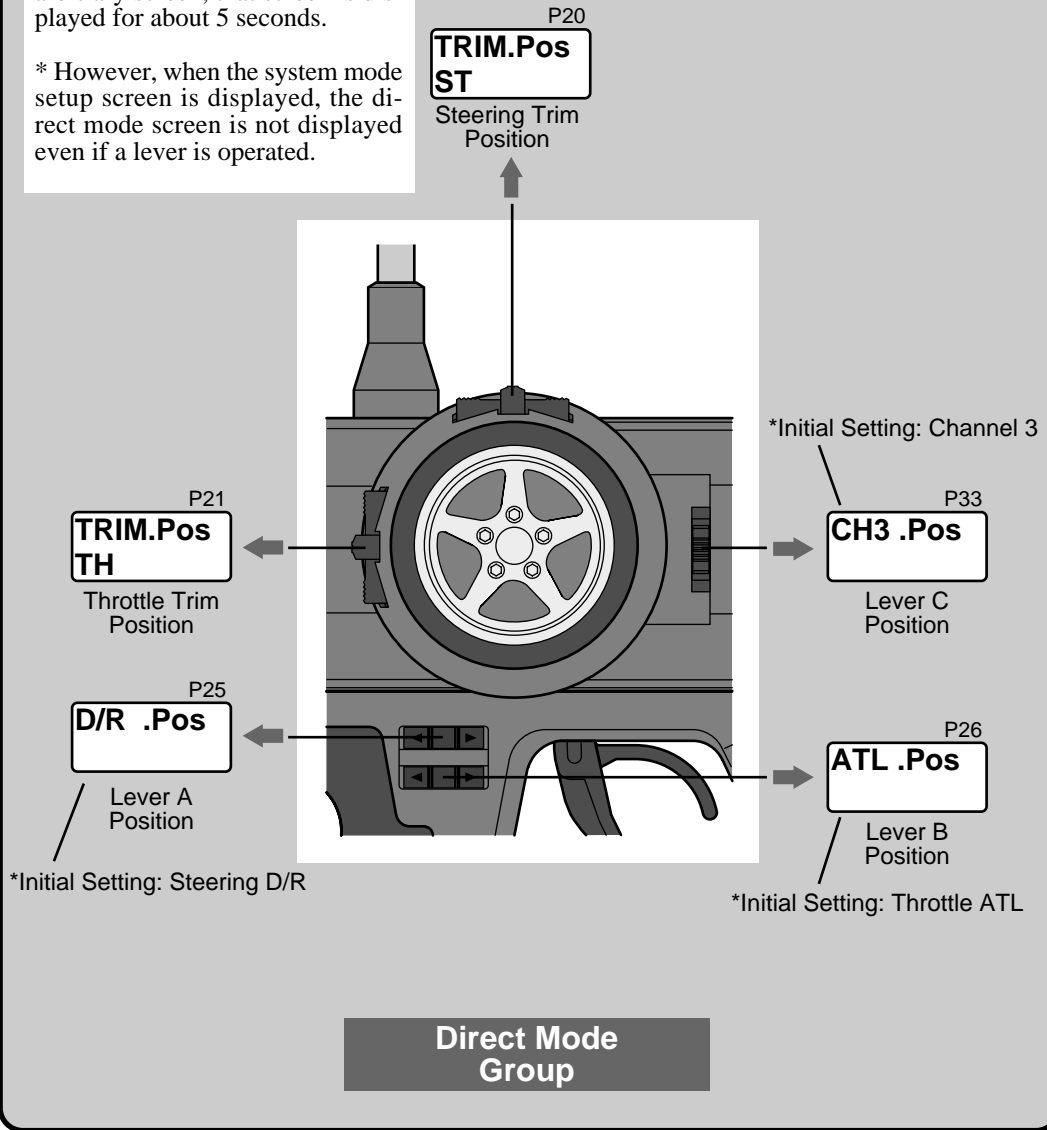

Steering Trim

The steering neutral position can be adjusted by moving the steering trim lever to left or right.

Use this function to make your model run in a straight line.

- At the initial screen where the Model number and Voltage are displayed the Steering Trim setting can be viewed by pressing the Trim lever to the left or right. If the Steering trim is not operated for 5 seconds the display will return to the initial screen.

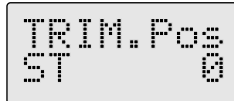

-When the SYSTEM MODE GROUP is displayed the steering trim position will be displayed.

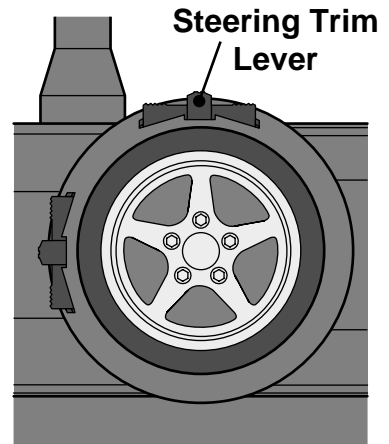

Racers Tip

Adjust the servo horn and linkage so they are parallel. If you are using a servo saver be sure the Steering trim is as close to neutral as possible. Check the transmitter steering trim and be as close to 0 as you can. Also check the instruction manual of the model this system is to be installed in for the correct servo position.

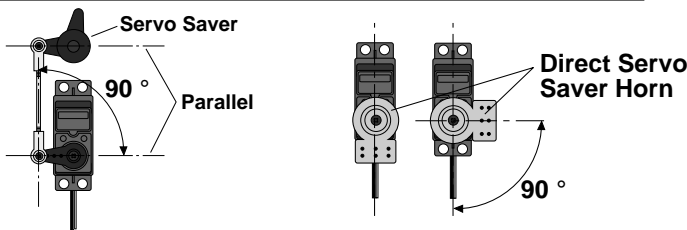

Trim Operation and Maximum Travel

Trim adjustments will change the servo movement range. When you make large trim adjustments recheck your maximum servo travel. (Steering ATV Right side and Left side)

When Trim Adjustments are Large

When the trim adjustments have caused the neutral to shift considerably to the left or right you may need to readjust the linkage.

Throttle Trim

The Throttle neutral position can be adjusted by moving the throttle trim lever up or down.

- 1 At the initial screen where the Model number and voltage are displayed the Throttle Trim setting can be viewed by pressing the trim lever up or down. If the Throttle trim is not operated for 5 seconds the display will return to the initial screen.

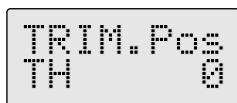

-When a System Mode Group screen is displayed the throttle trim position will not be displayed.

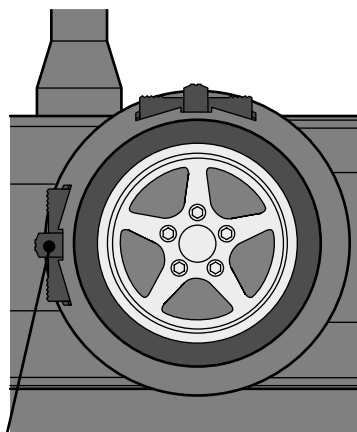

Throttle Trim Lever

Racers Tip

When using a FET Amp (Electronic speed control) set the screen to 0 and make the neutral adjustments at the FET Amp. For gas powered models adjust the throttle linkage as described in the engine instruction manual. When 0 is displayed the carburetor should be fully closed

Carburetor Fully Closed

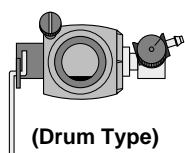

(Drum Type)

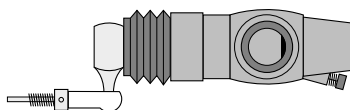

(Slide Type)

Trim Operation and Maximum Travel

Trim adjustments can change the servos overall travel. If large adjustments are made you may need to readjust the brake side movement. Check the Throttle ATV B side and the Throttle ATL. The forward may not be effected but should be checked.

When Trim Adjustments are Large

When the trim adjustment is large enough to cause the neutral to shift considerably to the forward or brake side you may need to readjust the linkage.

Servo Reverse

This function will reverse the rotation direction of the Steering, Throttle and Channel 3 servos.

If the trim position is not set to 0. The servo will shift the same amount off neutral on the opposite side when the servo is reversed.

- 1 Access the SYSTEM MODE by pressing the SELECT and MODE Keys simultaneously



- 2 Access the Servo Reversing Function screen by pressing the MODE KEY Once.



- 3 Select the channel you wish to change by pressing the SELECT KEY.

ST: Steering
TH: Throttle
CH3: Channel 3



(Direction Setting)

- 4 Change the rotation direction with the + or - key.

NOR: Forward Direction
REVE: Reverse Direction

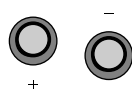

Channel 3 Operation

When CH3 (operation function selection) is set to 1P-4P, the lever direction versus position movement can be changed.

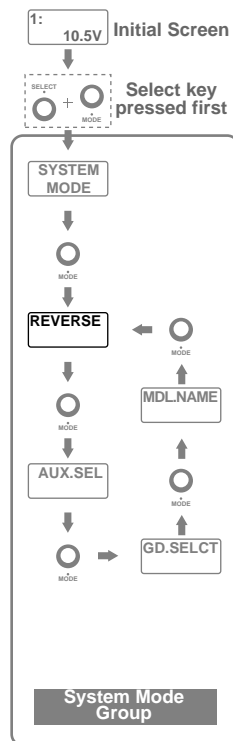

Steering ATV

Use this function to limit the servo movement to the left or right. The servo travel to each side can be independently adjusted. This feature will compensate for any difference in right or left turning angles or radius due to the characteristics of your model.

Warning

 Be sure that the steering linkage does not bind or come in contact with any suspension parts or arms.

If unreasonable force is applied to the servo. The servo may be damaged could cause loss of control.

(Steering ATV Selection)

- 1 Access the FUNCTION MODE by pressing the MODE key from the initial screen.

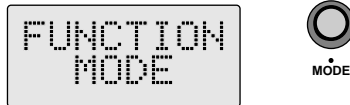

- 2 Access the Steering ATV Function by pressing the MODE KEY two times.



(Steering right side adjustments)

- 3 With the steering wheel turned fully to the right adjust the right side travel by pressing the + or - key.



(Steering Left Side Adjustment)

- 4 With the steering wheel turned fully to the left adjust the left side travel with the + and - keys.



When you want to adjust both directions simultaneously.

When the + key or - key are operated when the steering wheel is at the neutral position the right side and left side directions change simultaneously.

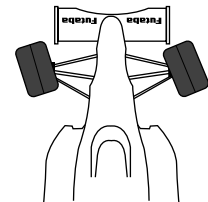
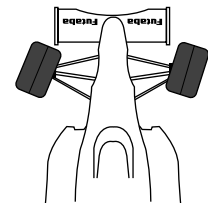
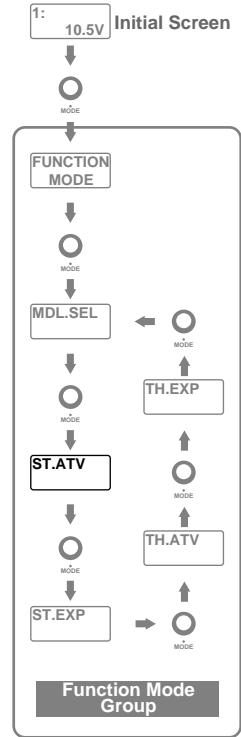

Setting Range: 0~120

(Pressing the + key and - key simultaneously returns the initial setting 100)

Throttle ATV

This function is used to adjust the forward and brake side servo travel. Each direction can be adjusted independent of each other. Use this feature to set the throttle servo travel.

Warning

Be sure that your throttle linkage does not apply excessive force to the servo.

If your linkage installation causes an unreasonable amount of force to be applied to the servo. The servo may be damaged and result in loss of control.

(Throttle ATV Selection)

- 1 Access this function by pressing the MODE KEY from the initial screen.

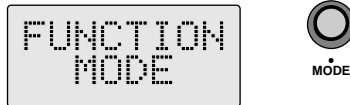

- 2 Access the THROTTLE ATV screen by pressing the MODE KEY four times.

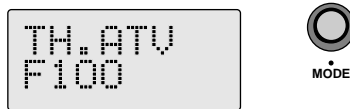

(Throttle Forward Side Adjustment)

- 3 Pull the throttle trigger back and adjust the forward side travel by pressing the + or - key. When a FET Amp (Electronic speed control) is used set to 100.

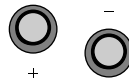

(Throttle Brake Side Adjustment)

- 4 First set the ATL lever to the maximum travel position (100).
- 5 Push the throttle trigger fully forward adjust the servo travel by pressing the + and - keys.

When an FET Amp (Electronic speed control) is used set to 100.

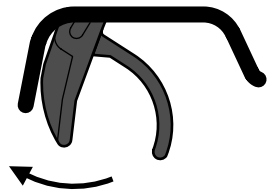
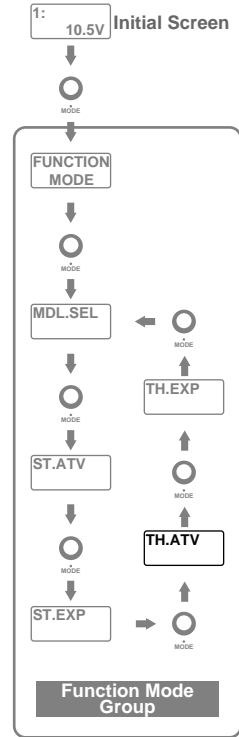
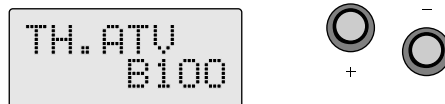

Setting Range: 0~120
(Pressing the + and - keys simultaneously returns setting to initial value 100)

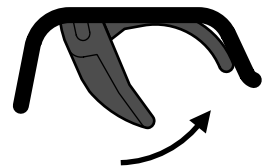

Setting Range: 0~120
(Pressing the + and - keys simultaneously returns the initial value 100)

Steering D/R

(Description when D/R lever is assigned to GDA)

This function is used to limit the steering servo travel. This feature will limit the servo travel equally in both directions. If the car tends to understeer (push) when cornering add servo travel. If the car tends to oversteer (loose) take servo travel out.

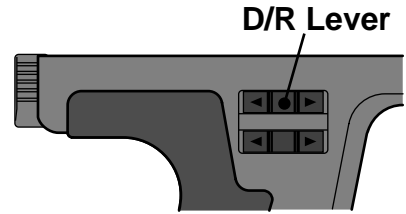

- 1** At the initial screen or a Function Mode Group screen . The D/R position will be displayed by pressing the D/R lever to the left or right. If the lever is not operated for 5 seconds the display will return to the initial screen.



When a SYSTEM MODE GROUP screen is displayed the D/R position will not be displayed.

- 2** Adjust the steering servo travel by pressing the D/R lever to the left or right.

Setting Range: 0~120
(The maximum travel can also be limited by the ATV function)

Throttle ATL

(Description when ATL is assigned to GDB)

This function is used to adjust the brakes. If you are getting too much brake in the car set the ATL number to a lower setting. When you need more brakes set the number to a higher setting.

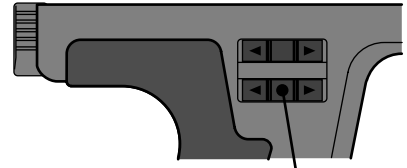

ATL Lever

- 1 At the initial screen or Function Mode Group screen. The ATL will be displayed by pressing the ATL lever to the left or right. If the ATL lever is not operated for 5 seconds the screen will return to the initial screen.



If a SYSTEM MODE screen is displayed the ATL position will not be displayed.

- 2 Adjust the brake side servo travel by moving the ATL lever to left or right.

Setting range: 0~ 120

(The maximum setting is the travel set at the throttle brake side)

Steering Exponential

Use this function to change the sensitivity of the steering servo around neutral. The - side will make the servo less sensitive around neutral. The + side will make the servo more sensitive around the neutral.

Racer Tip

When the handling characteristics of a model are unknown begin at 0%. At 0% the servo movement is linear.

- 1 Access this function by pressing the MODE KEY from the initial screen.



(Steering EXP Selection)

- 2 Access the Steering EXP screen by pressing the MODE KEY three times.



(EXP Adjustment)

- 3 When you want the servo reaction to be more sensitive adjust with the + key. When you want the servo reaction to be less sensitive adjust with the - key.

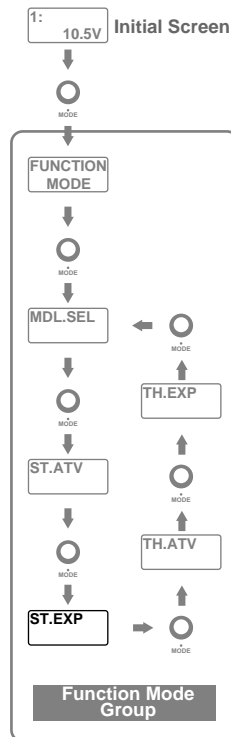
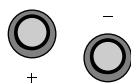

Setting Range: -100~0~+100
(Pressing the + and - keys simultaneously will return the setting to the initial value 0.)

Throttle Exponential

This function will allow you to change the sensitivity of the throttle servo. The + side will make the servo reaction move sensitive while - side will make it less sensitive.

Racers Tip

When track conditions are good experiment with the + side. When track conditions are not ideal experiment with the - side.

- 1 Access the function by pressing the MODE KEY from the initial screen.

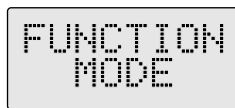

(Throttle EXP Selection)

- 2 Access the Throttle EXP screen by pressing the MODE KEY five times.



- 3 Pull the throttle trigger fully back. When you want the servo reaction to be more sensitive adjust with the + key. When you want the servo to less sensitive adjust with the - key.

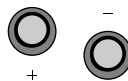

(Brake Side Adjustment)

- 4 Push the throttle trigger fully forward. When you want the servo to react quickly adjust with the + key. When you want the servo to react mildly adjust with the - side.

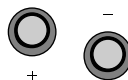

When E.S.C. (With reverse) is used.

The EXP function will not be dynamically be felt in reverse.

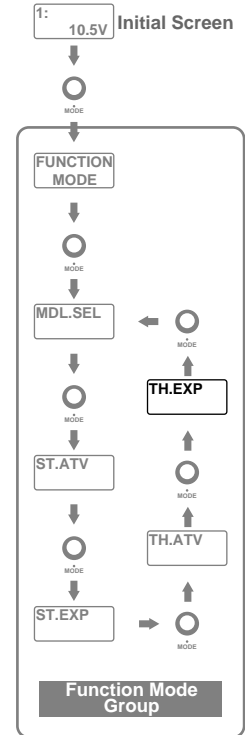

Setting Range: -100~0+100
(Pressing the + and - keys simultaneously returns setting to initial value 0)

Setting Range: -100 ~ +100
(Pressing the + and - keys simultaneously returns the setting to the initial value 0)

Model Select

The 3PDF can store the data for 3 different models.

The MODEL SELECT function is used to access each model memory. Use this function when you change from one model to another.

- 1 Access this function by pressing the MODE key from the initial screen.



(Model Select Function>

- 2 Access the model select screen by pressing the Mode key two times.

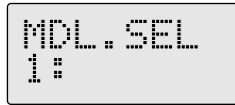

(Model Number Selection)

- 3 Call the desired model number with the + or - key.

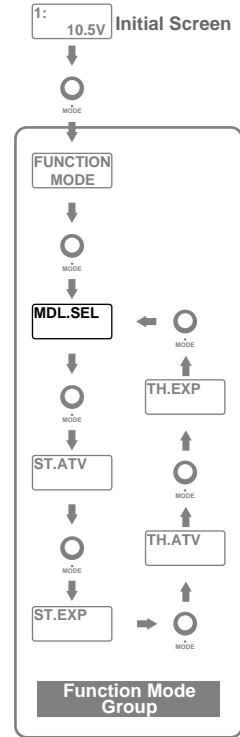
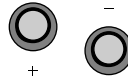

Model Name

Up to 6 characters can be used to assign each model memory a name. Alphabetic, numeric and symbols can be used. This will make your model memos easy to tell apart.

- 1 Access the SYSTEM MODE by pressing the MODE KEY and SELECT KEY simultaneously from the initial screen.



(Model Name Selection)

- 2 Access the model name screen by pressing the MODE key four times.

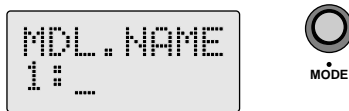

(Selection of characters to changed or used)

- 3 Select the character you want by pressing the SELECT key.



(Setting New Character)

- 4 Set the new character with the + and - keys

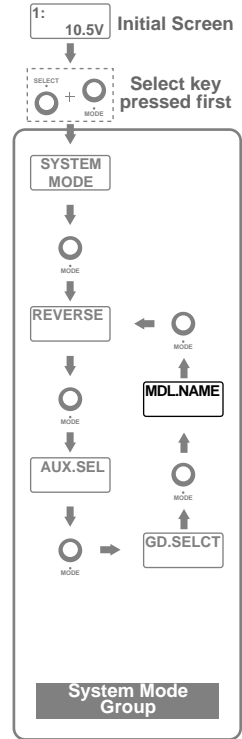
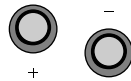

* Pressing the + and - keys simultaneously will erase all the characters assigned to that model memory name.

Usable Characters

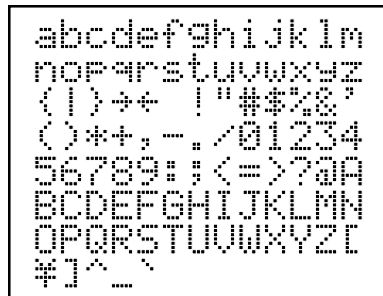

Lever Function Select

This function will allow you to assign different functions to the levers. The steering D/R Throttle ATL and Channel 3 can be assigned to these levers.

- 1 Access the System mode by pressing the Mode key and Select key simultaneously from the initial screen.



(Lever function select selection)

- 2 Access the lever function select screen by pressing the Mode key three times.



(Selection of Lever to be assigned)

- 3 Select the desired lever by pressing the Select key.

GDA: Lever A
GDB: Lever B
GDC: Lever C



(Function Selection)

- 4 Select the desired function with the + or - key.

D/R: Steering D/R
ATL: Throttle ATL
CH3: Channel 3

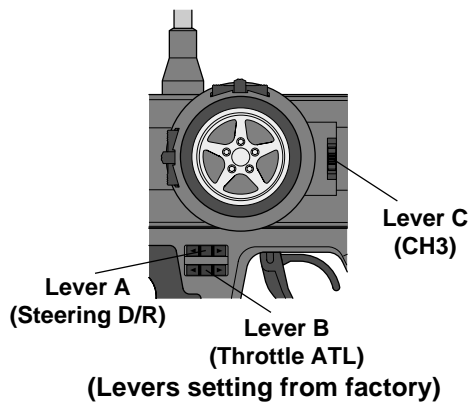
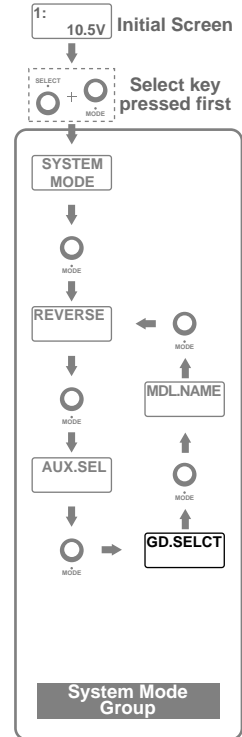
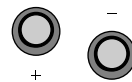

Channel 3 Function Selection

The channel 3 operation can be selected from the following functions.

- 1P: The third channel will operate like a self return switch. The servo will move from servo position (P1) when the lever is not operated to servo position (P2) while the lever is operated. This function is convenient when a on board engine is used.
- 2P: Channel 3 operates like a 2-position Lever operation moves the servo to two positions: servo position (P1) and servo position (P2). The servo stops at each function.
- 3P: Channel 3 operates like a 3-position switch. Lever operation moves the servo to three positions: servo position (p1) servo position (P2) and servo position (P3). The servo will stop at each position.
- 4P: lever operation moves the servo to four positions: servo position (P1) servo position (P2) servo position (P3) and servo position (P4). The servo stops at each position.
- Lin: lever operation moves the servo from the R (right side) to L (left side) in steps This is convenient when FET Amp MC510CB with current control is used.

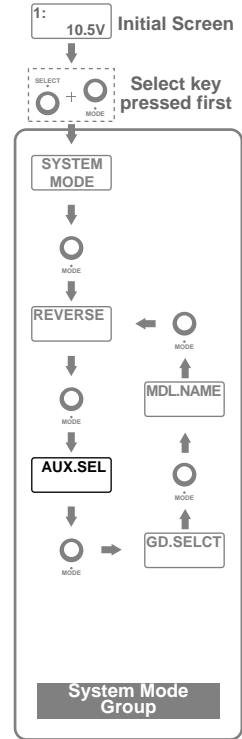

- 1 Access the System Mode by pressing the Mode and Select key simultaneously.



(Setup Screen Selection)

- 2 Access the channel 3 function by pressing the Mode key two times.

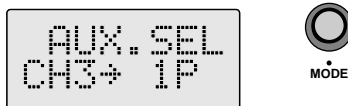

(Function Selection)

- 3 Select the desired function with + or - key.

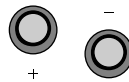

Travel and Servo Position Setting

Set the LIN type maximum travel and the 1P~4P type servo position at the CH 4 position display screen

Position Movement Direction

When 1P~4P type is selected the direction of the movement by lever operation can be changed with the servo reversing function

CH3 Position Setting

(Description is with the CH3 lever position in the initial setting)

* Before using this function to select the servo position to used with each function. Select the CH3 operation function selection function. (P32).

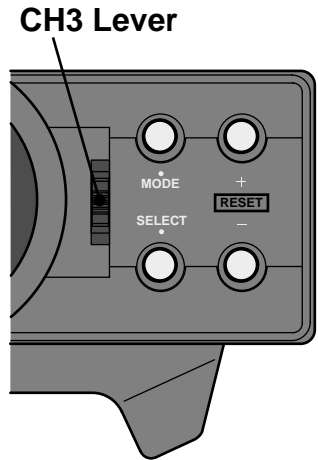

(When LIN Type is Set)

The maximum travel can be set

When used with MC510CB

-Screen Display + 100~140A

-Screen Display -100~10A

First set to +100 with the CH3 lever and drive the car. If the car is difficult to drive decrease the displayed value by moving the lever to the - side.

(When 1P~4P Type is set)

the servo operation position for each position can be set by calling the setup screen for each position by operating the CH3 lever.

- 1 When the initial screen or a function mode setup screen is displayed. You can view the CH 3 position by moving the CH 3 lever up or down. If the lever is not operated for 5 seconds the display will return to the initial screen.

```
CH3 .Pos
LIN +100
```

When a System Mode Group screen is displayed the CH 3 position will not be displayed.

(LIN Type Setting)

- 2 When adjusting the lever up side throw hold the lever in the top position. If the tone changes adjust the throw with the + or - key.

When setting the lever down side throw hold the lever in the down position. If the tone changes adjust the throw with the + or - key.

Setting Range: -100~+100

(Pressing the + and - keys simultaneously will return the value to the initial value 0)

(1P ~ 4P Type Setting)

To view each position operate the CH 3 lever and set the servo operation position by pressing the + or - key.

```
CH3 .Pos
P1 -100
```

```
CH3 .Pos
P2 +100
```

```
CH3 .Pos
P3 0
```

```
CH3 .Pos
P4 0
```

Ratings

* Specifications and ratings are subject to change without prior notice.

Transmitter: T3PDF

(Wheel Type 3 Channel)
 Transmitting Frequency:
 27, 29, 40, 41, or 75mhz band.
 Modulation: FM (Frequency Modulation)
 Power Requirement:
 12 Volts (8 AA size batteries) or 9.6 Volt Nicad.
 (Optional Nicad Battery) NT-8JY
 Current Drain: 230ma Maximum

Frequencies allocated for surface in USA by F.C.C.
 27mhz Channels 1-6
 75mhz Channels 61-90

Servo S3003

(Standard Servo)
 Power Requirement: 4.8 Volts or 6 Volts (Shared with receiver)
 Current Drain: ma (Stopped)
 Output Torque: 42.0 oz/in
 Operating Speed: 0.22sec./60
 Size: 0.77" x 1.59" x 1.41"
 Weight: 1.5oz.

Receiver R113F

(CH 3 FM Receiver)
 Receiving frequency:
 27, 29, 40, 41, or 75mhz band.
 Intermediate Frequency: 455khz
 Power Requirement:
 4.8 Volts or 6 Volts (Shared with servo)
 Current Drain: 16mA
 Size: 1.13" x 1.69" x 0.63"
 Weight: 0.72 Oz.

FET Amp MC210CB

(FET Amp with Reverse)
 Voltage Drop: Approx. 0.52V/20A (Between amp input and output)
 Maximum Current: 20A (Fuse capacity)
 Power Requirement: 7.2 ~ 8.4 Volts
 Regulator Output: 6V/3A (Maximum)
 Size: 1.79" x 1.63" x 1.02"
 (Excluding heat sinks and protruding parts)
 Weight: 2.55oz

Optional Parts

The following parts are sold separately as optional parts. Refer to the Futaba catalog for more information.

Futaba Crystal Sets:

FM 27MHz Band crystal
 FM 75MHz Band crystal
 (FM single conversion sets only)

There are two types of FM crystals. Dual and Single Conversion.
 (Use single conversion with this system.)

Frequency Flag:

Please specify the frequency used

Transmitter Nicad Battery:

NT-8JY Nicad battery Pack

Body Rest:

Body Rest for 3PDF

Colored Steering Wheels:

available in Red Blue and Green

Colored Grips:

available in Red Blue and Green

A smaller size grip

Troubleshooting

If your system fails to operate or you experience a short range problem or erratic control. Check the table below for reasons you may be having these problems. After you followed the suggestions listed and the problem is not corrected return the system to our service department for inspection and repair.

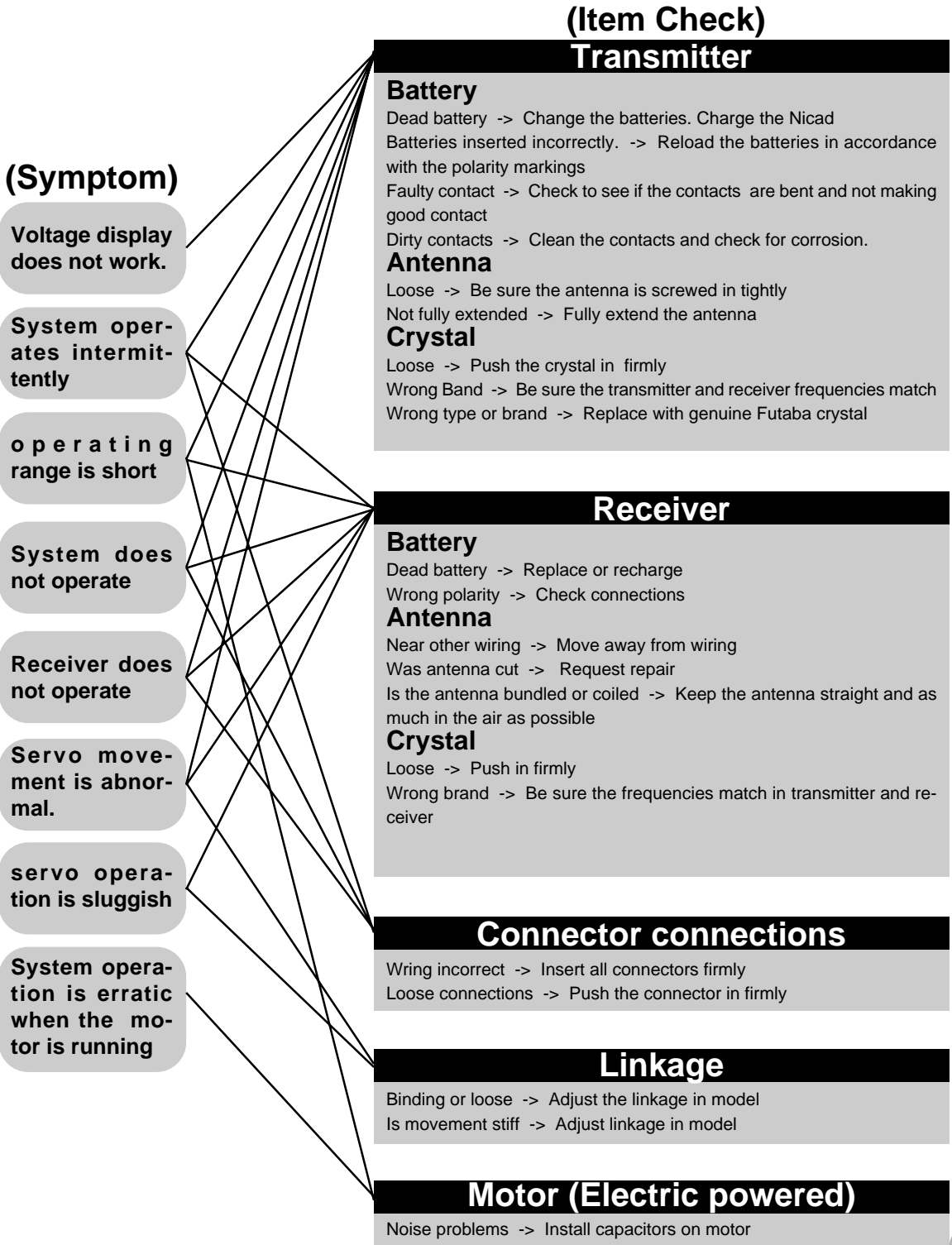

Glossary

The following defines the symbols and terms used in this instruction manual

Band

Frequency that receiver and transmitter operate on.

Channel

Represents the number of functions the transmitter will control.

Kit

A set of parts manufactured for building a model.

Modulation method

Two modulation methods are used with R/C systems: AM (Amplitude Modulation) and FM (Frequency Modulation). Another method that encodes and transmits the modulated signals is called "PCM".

Neutral

The center position. It is the point where the steering wheel and throttle return to when they are not being operated

Proportional

Because today's R/C systems control servos in proportion to the transmitter operation they are called proportional.

Servo Horn

The part that is installed on the output shaft on the servo to convert to rotating motion of the servo to transmit the linear to a control rod., Servo horns come in various shapes.

Servo Mount

Advise used to secure the servo in the model. (Most often supplied in the model kit)

Steering (ST)

System to make the model turn left or right using the front wheels.

Steering Wheel

A devise for controlling the steering from the transmitter. It is shaped like a wheel.

Throttle

Devise that controls the air mixture at the engine intake. When opened a large air mixture is sucked in and the engine speed increases. When closed the engine speed decreases.

Throttle Trigger

Devise provided on the transmitter to control the throttle. It is shaped like the trigger on a gun.

Trim

Devise that fine adjusts the neutral point of each servo.

