



MC401CR INSTRUCTION MANUAL

Thank you for purchasing an MC401CR. The MC401CR is a high-frequency drive FET speed control developed for model electric cars. It is compact and light weight competition speed control, and uses a simple digital setting system.

FEATURES

- **SMD MOSFETs with smallest internal resistance for minimal losses and maximum power**
- **Forward, reverse, and brake operations are all linear**
- **Reverse operation cancellation function**
- **PWM frequency is Performed by load adaptive**
- **Heat protector**
- **Low-voltage protection function**
- **Fuse 30A** (Buttery reverse ptection / Overload ptection)
- **Power left on alarm function**
- **Serial communication function**

Power supply

Nicd, NiMH battery 4~6 cells
(4.8~7.2V)

[MC401CR Technical Data] (Specifications are subject to change without prior notice.)

- Operating system: Forward and brake (resolution:255)
- Power requirement: Nicd, NiMH battery 4~6 cells (4.8~7.2V)
- PWM frequency:
Forward:100Hz~10kHz / Initial value:2.5kHz~3.0kHz
Brake:2.0kHz
- BEC voltage: 6.0V (excluding at less than 6V)
- Setting: One-touch input by pushbutton switch.

1M23N20402

Before using your MC401CR, please read this manual thoroughly and use the MC401CR properly and safely. After reading this manual, store it in a safe place.

- No part of this manual may be reproduced in any form without prior permission.
- The contents of this manual are subject to change without prior notice.
- This manual has been carefully written. Please write to Futaba if you feel that any corrections or clarifications should be made.

Accessories

- Capacitors (for motor)
- Tie strap
- Double sided tape
- Miniature screwdriver (Use to press the pushbutton switch.)

Applicable motors (Number of turns is criteria.)

Use the MC401CR with a motor with 10 turns or more.

*If a motor with a number of turns smaller than the above is used, the heat protector and overcurrent protection circuit may operate. The number of turns of the motor is a criteria only. Depending on the running conditions, the protection circuit may operate even if the condition above is satisfied.

*The internal circuit of MC401CR is OK up to 10-turn motors. On the other hand, the connectors for battery and motor are general type that is often found at the dealers. Therefore, to use high output power motor or apply heavy load may result in overheating of the connector section and melting the connection. If this happen the connection will stick together. Please pay special attention to avoid this matter.

- Current capacity (FET rating):
Forward :360A (Momentary load: 1440A)
Reverse :120A
- Fuse: 30A (Buttery reverse ptection / Overload ptection)
- Case size: 25.7x26.2x12.9mm (excluding protruding parts)
- Silicon cord gauge size: AWG14 equivalent
- Weight: 11.2g (excluding connector, cords and switch)

Serial communication function (Options)

The following settings and operations are possible with a Windows PC by using the optional interface unit (CIU-2).

- Data logging function data read and erase (Data logging memorizes the running current and power supply voltage for approximately 8 minutes at 1 second intervals.)
- Variable frequency range setting: 100Hz ~ 10kHz (Sets the load response system variable frequency range.) Dead band: $\pm 2\mu s$ ~ $\pm 55\mu s$ (The neutral point range can be set.)
- Low battery protection voltage setting: 2.5V ~ 6.0V (Sets the voltage which cuts output to motor when the power supply voltage is drops.)
- Current limiter: 50A ~ 300A, cancel (The current limit for suppressing wasted power can also be set and turned OFF.)
- Brake MAX duty: 0% ~ 100% (Sets the brake strength of the MAX brake point from neutral.)
- Neutral brake: 0% ~ 100% (Brake setting at the throttle neutral point)
- Reverse: cancel / robot (Forward \leftrightarrow neutral \leftrightarrow reverse)

*Windows is registered trademark of Microsoft Corporation.

MOUNTING PRECAUTIONS

⚠ WARNING

- 1 Install the receiver and receiver antenna away from the amp, motor cord, power cord, Nicd battery, and other parts that carry a high current.
- 1 Metal and carbon chassis and other conductive parts transfer switching noise. When mounting the receiver to such a chassis, use thick double-sided tape to mount the receiver as far away from the chassis as possible.
- 1 Always install a motor noise suppresser capacitor. Also, do not forget to service the brushes, and other parts.
If noise causes the receiver to operate erroneously, control may be lost and an extremely dangerous situation may occur
- 1 Insert the connectors firmly.
If vibrations while running cause the connectors to work loose, control may be lost and an extremely dangerous situation may occur.

⚠ CAUTION

- ⊘ Do not wrap your MC401CR in foil.
It is important to provide a free flow of cooling air over it.
- 1 Do not remove the case of MC401CR.
The MC401CR may not be repairable.
- 1 Never reverse the battery polarity.
Reverse connection will immediately destroy the amp.
- ⊘ Mount the MC401CR so that conductive parts do not directly touch the solder parts of the input/output cord.
A short circuit may occur.

MOUNTING PRECAUTIONS

⚠ WARNING

- ⊘ Do not run the vehicle in the rain or through puddles or on muddy or snowy roads.
If moisture enters the amp, erroneous operation may cause loss of control and an extremely dangerous situation may occur. It may also cause amp trouble. Should moisture enter and cause erroneous operation, send the MC401CR out for repair and inspection.
- 1 Always turn the power switches on and off in the following order:
ON: Transmitter -> receiver (amp switch)
OFF: Receiver (amp switch) -> transmitter
If the power switches are operated in the opposite order, the vehicle may run unexpectedly and an extremely dangerous situation may occur.
- 1 When going to and returning from the circuit, and when storing the model, always remove the Nicd battery.
If the switch is turned on erroneously, control may be lost or a fire may start.
- 1 Always perform a check of operation before running.
- 1 When making adjustments, remove the motor, or place the vehicle on a stand, so that it cannot run.
When not set up correctly, the vehicle may run unexpectedly and an extremely dangerous situation may occur.

⚠ CAUTION

- ⊘ If a peddle or other foreign object gets caught in the gears or the vehicle hits an obstruction, do not try to forcefully run vehicle.
Forcefully running the vehicle will cause trouble.
- ⊘ Do not touch the motor or MC401CR immediately after running.
Touching the motor or amp immediately after running may result in serious burns.
- ⊘ If the motor is connected to the speed control, you must not run the motor by connecting a separate battery.
This will wreck the unit.
- 1 Turn the power switches on in the state where the vehicle is floated.
When turning on, depending on the receiver used, a motor may rotate for a moment. Be careful not to injure a finger etc. by rotation of the wheels.

Special Markings

Pay special attention to the safety at the parts of this manual that are indicated by the following marks.

- Symbol: ⊘ : Prohibited
! : Mandatory

Mark

⚠ DANGER

⚠ WARNING

⚠ CAUTION

Meaning

⚠ DANGER	Procedures which may lead to a dangerous condition and cause death or serious injury to the user if not carried out properly.
⚠ WARNING	Procedures which may lead to a dangerous condition or cause death or serious injury to the user if not carried out properly, or procedures where the probability of superficial injury or physical damage is high.
⚠ CAUTION	Procedures where the possibility of serious injury to the user is small, but there is a danger of injury, or physical damage, if not carried out properly.

INSTALLATION TIPS

- Mount the speed control in the model using the double-sided foam tape supplied.
- Provide plenty of cooling openings in the bodywork; this increases the performance and extends the life of all lectronic components.
- Install the speed control in a location where it is protected from crash damage.
- The speed control should be installed in such a way that you have easy access to all connectors and the set-up button.

Important:

- Ensure that there is an adequate distance (approx. 3 cm) between the speed control and power cables and the receiver or receiver antenna. Avoid direct contact between all power system components and the receiver or antenna, as this can cause interference. If you encounter interference problems, re-position the components in the model.
- The antenna should be run vertically up and away from the receiver. Avoid contact with any parts made of carbon fibre or metal. See also the instructions supplied with your radio control system.

CONNECTION

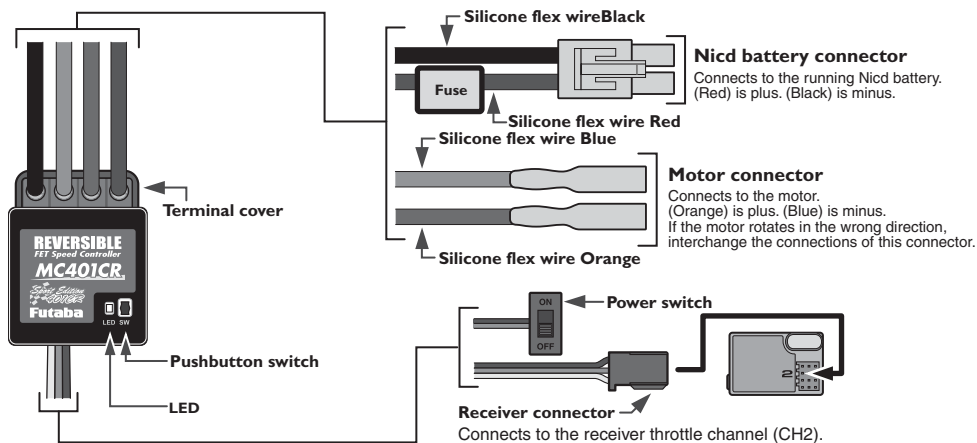

Solder the suppressor capacitors and the Schottky diode to the motor.

Motors with no suppressor capacitors, or inadequate suppression, may cause the MC401CR to malfunction. Always solder the capacitors supplied to your motor.

* Caution: never use Schottky diodes in conjunction with a forward/reverse speed control such as the MC401CR.

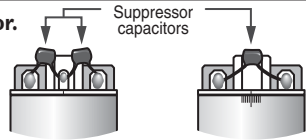

SET UP

In set-up mode MC401CR stores every step when you press the Set-up button. All the settings are stored in the unit even when the speed control is subsequently disconnected from the battery. Set up the following basic functions on your transmitter (if present):

- High ATV, EPA (throttle travel) - maximum Low ATV, EPA, ATL (brake travel) - maximum
- EXP, EXPO (exponential) - start with 0
- SUB trim (neutral trim) - center TH trim - center
- Throttle reverse (servo reverse) - any setting; must not be changed after completion of set-up procedure.
- Asymmetrical stick travel is possible (2/3 throttle - 1/3 brake)

If your transmitter does not feature these set-up functions, it is already in "basic set-up" mode.

Remove the motor pinion, or ensure in some other way that the wheels of the model are free to rotate.

1 Turn on the power in following order.

- Switch the transmitter on.
- Set the transmitter throttle stick to neutral, and then switch the speed control on.

* Depending on the neutral position of the throttle stick, the red and green LED will blink simultaneously (orange) and a beeping sound will be repeated. (Alarm: Waiting for neutral data)

2 Hold the SET button pressed in for at least 3 seconds using the small screwdriver supplied.

- The SET LED flashes green, to indicate that the unit is in set-up mode.

	Transmitter throttle operation	SET button operation	MC401CR LED
3	Neutral point setting Neutral state	SW Press SET button once.	LED LED goes out and the motor beeps.
4	High point setting Full high state	SW Press SET button once.	flashes green two times LED and the motor beeps. LED goes out
5	Brake MAX point setting Full brake state	SW Press SET button once.	flashes green three times LED and the motor beeps. LED goes out

- This completes the set-up procedure.

* Since the data is read at the end of setting of all points, the points cannot be set independently.

* If the amp power was turned off during setting, the setting points cannot be memorized. (The previous settings are retained.)

* The confirmation beep sounds only when the motor was connected.

* If you make a mistake during the set-up procedure, an setting is not completed.: switch MC401CR off and start again from the first step.

* Check the operation by the following "LED DISPLAY." When throttle operation and the CHECKER LED DISPLAY are not correct, set up again from the first step.

LED DISPLAY

• The MC401CR operating state can be checked with the LED as shown below.

• After operating the throttle trigger (stick) of a transmitter to the brake (reverse) side, if it is again operated to the brake side once it returns to a neutral position, MC401CR will carry out reverse operation.

Operation	Brake MAX point	Brake or Reverse	Neutral point	Foward	High point
LED	On (green)	Brake On (red) *Becomes brighter nearer the MAX point. Reverse On (orange) *Becomes brighter nearer the MAX point.	Off *at Neutral Brake: On (green or red)	On (green) *Becomes brighter nearer the high point.	On (red)

Cause	LED
(Amp power left on alarm) When the transmitter power was turned off first.	flashes red and the motor beeps. *Not used with PCM receivers. *When the transmitter is OFF, this function is not performed in environments such that the servo operates erroneously
(Alarm when waiting for the data of a neutral point) *When the switch of speed control is turned ON ahead of a transmitter. *When the neutral position of a transmitter differs from the last setup.	flashes orange and the motor beeps.
(Data error alarm) Displayed when an abnormal signal was input.	flashes red and the motor beeps.
(Protection circuit operation) When a protection circuit operates.	flashes orange

* The confirmation beep sounds only when the motor was connected.

Protection Circuits

Heat protection: After FET overheating is detected, the output to the motor is gradually lowered and when 115 degrees is reached, a protection circuit operation alarm is activated and output to the motor is cut. The protection circuit is automatically reset by a drop in the FET temperature.

Low battery protection: When the power supply voltage drops, the output current to the motor is limited and supply voltage to the receiver is ensured. When the power supply voltage drops to the set voltage (initial setting 3.0V), a protection circuit operation alarm is activated and output to the motor is cut. The protection circuit is automatically reset by recovery of the power supply voltage.

Reverse Cancelling function (Brake operation only)

While pressing the pushbutton switch, set the power switch to ON. flashes orange and the motor beeps. (5 times)

*When desired, you can enable the cancelled reverse function by repeating the operation shown above. (The reverse function is switched alternately.)

The reverse mode by LED can check.

Set the power switch to ON. flashes LED.

MODE	The mode to reverse	The mode to cancel reverse	The mode to robot
LED	flashes orange once	flashes red twice	flashes green 3 times