

HUDY

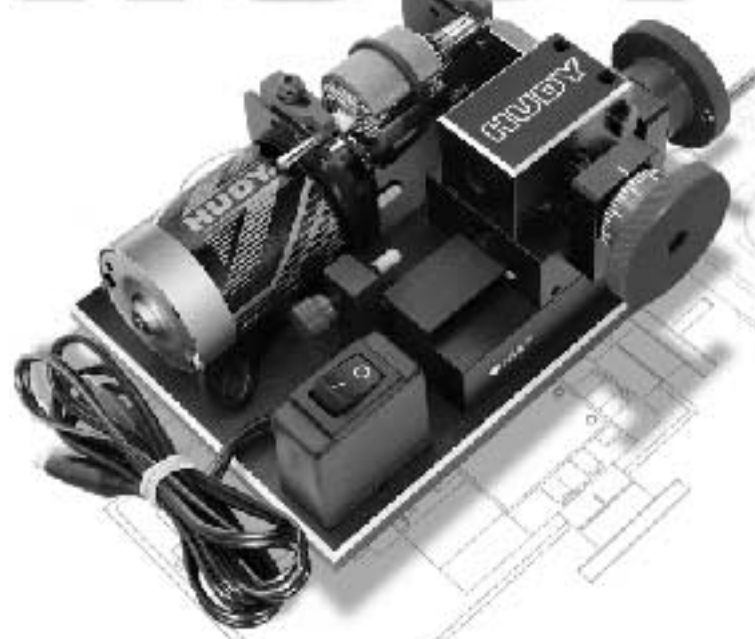

HUDY ADVANCED COMM LATHE FOR MODIFIED MOTORS

#10 1000-B - BALL-BEARING GUIDES
#10 1000-V - ULTRA-HARDENED STEEL "V" GUIDES

FOR SLOT CAR MOTORS

#10 1100-B - BALL-BEARING GUIDES
#10 1100-V - ULTRA-HARDENED STEEL "V" GUIDES

A new generation of commutator lathes is about to invade the lathe market. Here we come! **HUDY** has used their experience of many years of comm lathe designing to produce this masterpiece. □ This product will help you cut your commutators with perfect cylindricity, and keep the slave motor in good shape for a long time. Last but not least, this lathe is fully adjustable as far as reversability is concerned. All parts are precisely produced on **CNC machines** from quality duraluminum. Guides for armatures are either ball-bearings or ultra-hardened steel "V" guides, both of which provide the best possible alignment. Teflon strips in the dovetail guide help the supports move easily. The pressure on those strips can be adjusted by a pair allen screws, located on the front of the bottom block, to provide smooth operation. A similar adjustment for the operating wheel clearance is available on the left side of the tool holding block. Both these adjustments enable this product to be slop-free, and achieve ultimate smoothness. A fine pitch thread is used on the feed screw; one graduation on the feed knob corresponds to a 0.01 mm movement of the tool bit, all this without backlash.

- please read the following instructions carefully before using
- when working with the lathe, please use protective glasses
- do not touch the rotating parts of the lathe

For best performance it is recommended to purchase:
#10 1084 Diamond Cutting Tool
#10 1900 Hudy Axial Support (ball-bearing or hardened "V" guides)

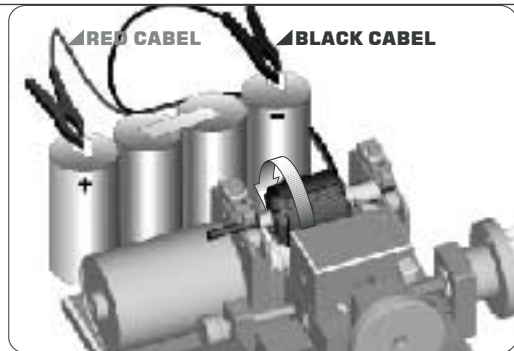

(1.) Connect the lathe to a 4.8 V source (4x1.2 batteries). When connecting the motor to the power supply, please watch for the right polarity. The slave motor must be turning clockwise when seen from the endbell. If you are using a DC power supply, make sure it can output at least 5A.

(3.) It is necessary to adjust the cutting bit:

(3.1) By using provided shims, adjust the cutting tool, so that the edge lays just above the center of the commutator to be cut - make sure that the tool will not crash with commutator or stands !!!

(3.2) Always keep a 0.15 - 0.20 mm distance between the cutting tool and the ball-bearings or hardened steel "V" guides. The height of the cutting tool is adjusted through provided different shims that should be inserted under the cutting tool.

There are provided following shims:
0.2 mm - 2x
0.3 mm - 1x
0.5 mm - 1x

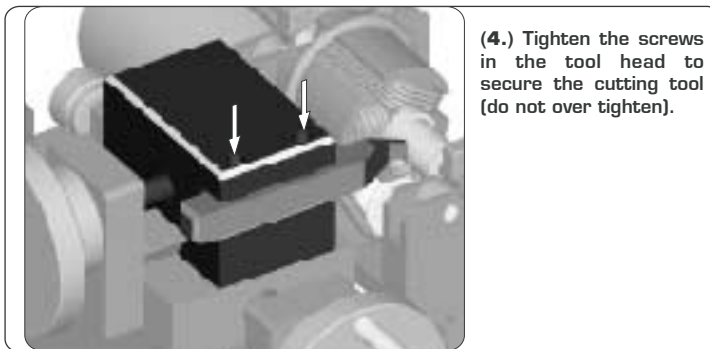
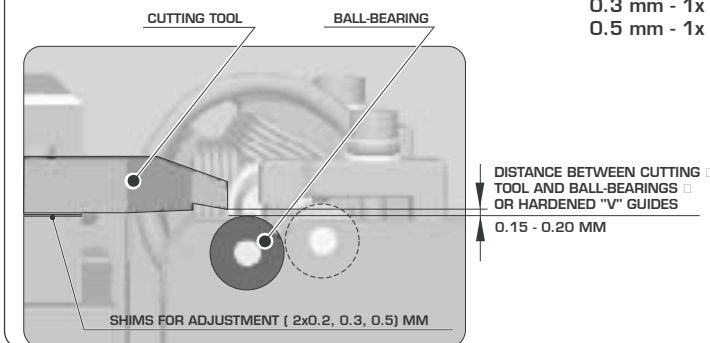

(4.) Tighten the screws in the tool head to secure the cutting tool (do not over tighten).

(5.) With the ultra-hardened steel "V" guides, we recommend you lubricate the contact area with graphite powder, to reduce friction, and extend the lifetime of the "V" guides. However, after a certain time, the guides will begin to groove where the armature sits. This seating should not be considered as wear, but rather as a normal break-in of the guides.

(6.) Back stop adjustment:

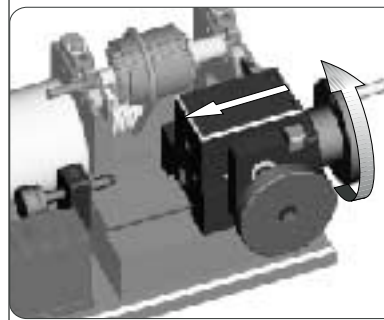

(6.1.) Turn the right operating wheel to the right. □ This will cause the tool block to move progressively to the left. □ Turn the operating wheel until the tool reaches the end of cut position.

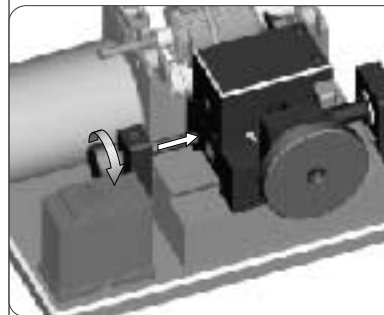

(6.2.) Now turn the small back stop adjustable screw until it will touch the support. □ This adjustment will help you not hit the edge of the commutator as well as the wire tabs with the bit during the cut.

(Important - the cutting tool must be sitting away enough from the commutator to avoid any damage!)

(7.) Cutting procedure:

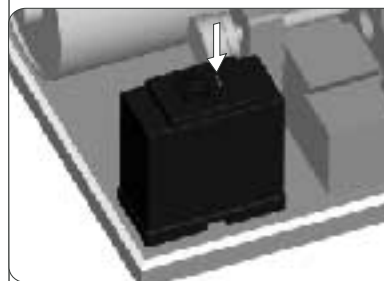

(7.1.) Turn the switch on. The slave motor starts turning the commutator and the cutting can start.

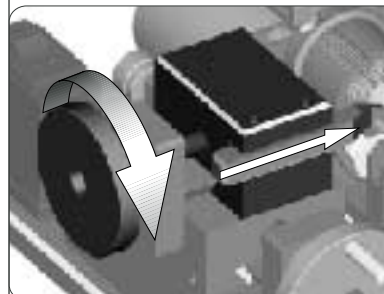

(7.2.) Turn the tool slowly □ to engagement.

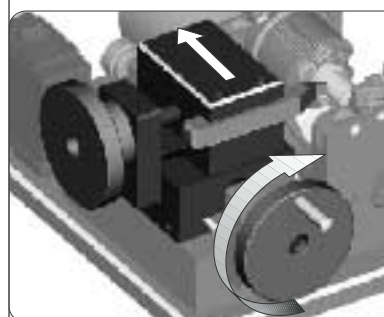

(7.3.) Use the operating wheel to move the bit across the comm.

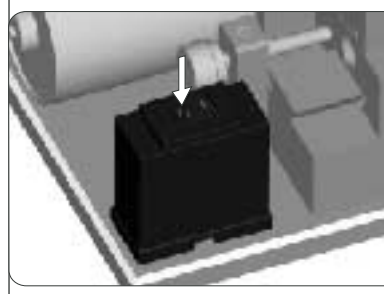

(7.4.) The slave motor will be turned off by moving the switch to the null position.

When you are done, remember to pull the bit far enough from the comm, to prevent any damage while removing it from the stands.

TROUBLESHOOTING

(1.) If the lathe does not work at all after turning it on:
- check the power source and connection.
- check for possibly damaged switch.

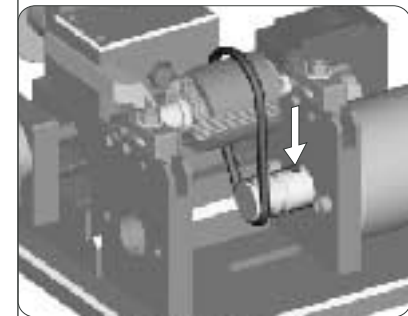

(2.) After switching the lathe on, the middle holding the pulley is not turning, but the main motor is turning:
- check the excessive backlash of the pulley.

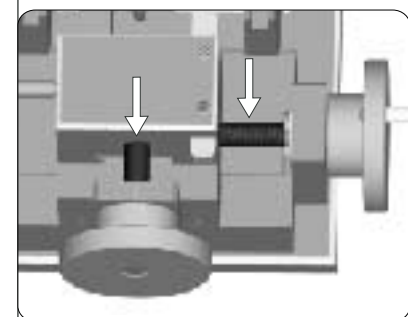

(3.) Verify that the MOTION SCREWS are running free. If they are binding, disassemble and clean them.

MAINTENANCE

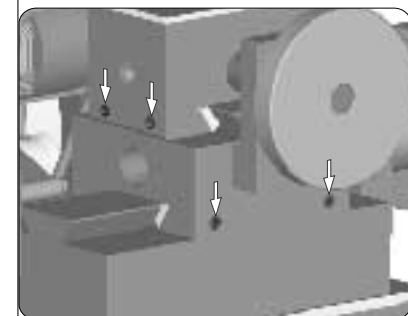

(1.) It is possible to easily and exactly adjust the clearance of supports through screws in the front of the bottom support and in the left of the tool block (the clearance is already adjusted by Hudy team out of the box, but can be further adjusted if need is).

(2.) All surfaces must remain clean, particularly feeding screws, threads, and contact areas between blocks. It is recommended you regularly clean and lubricate them.

(3.) The guides (ball-bearings or ultra-hardened steel "V" guides) must remain clean.

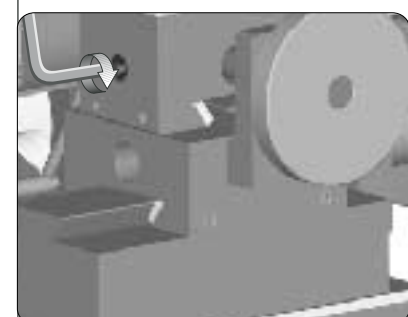

(4.) It is possible to easily and exactly adjust the tolerance of the operating wheel of the cutting tool through screw with plastic insert-pad in the left side of the tool head (the clearance is already adjusted by Hudy team out of the box, but can be further adjusted if need is).

We hope you will be satisfied with the performance and quality of this equipment. If you have any questions or advice about how to even improve this machine please do not hesitate to contact us.

Thank you for choosing Hudy products!

www.hudy.net