



#3022 MIP 360° Stinger Kit for Nitro Rustler #330

Follow instructions carefully to install the MIP 360° Stinger™ onto your Traxxas Nitro Rustler. The kit is designed to work on the TRX, Image, OS, Dynamite, and Yokomo gas engines, with or without pull starters. Please read instructions completely before starting your installation.

- Step 1:** Remove Stinger™ brace by breaking the tabs from the center of the MIP shock tower.
- Step 2:** Remove the stock exhaust system and replace standard rear shock tower with the MIP shock tower.
- Step 3:** Use two 1" alloy screws and supplied gasket to secure 360 header onto your .12 engine.
- Step 4:** Use soapy water to lubricate the black header hose while stretching it over the end of the Stinger™.
- Step 5:** Before mounting the Stinger™ onto the 360 Header, cut a 2" piece of supplied fuel tubing and slit it to use as a cushion between the Stinger™ and shock tower bore (Fig. 1). Now slide Stinger™ through MIP tower and onto 360 Header all the way forward until header hose just starts to cover the beginning curve of the 360 Header. The 360 Header can be tweaked slightly to center the Stinger™ in the MIP tower bore. Use the two supplied black high temp. tie wraps to secure Stinger™ onto 360 Header (Fig. 3).

Fig. 1

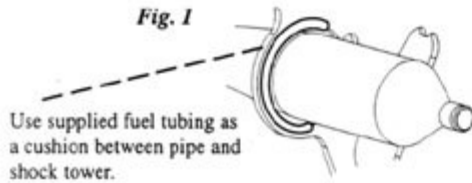
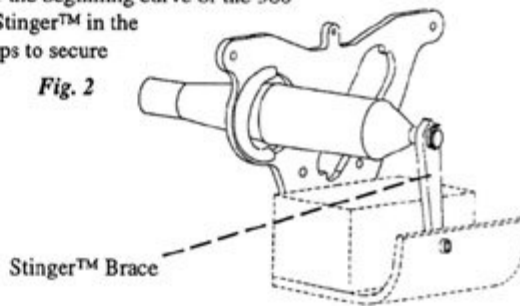

Fig. 2



- Step 6:** Drill a 1/8 inch hole in rear bumper, location specified in (Fig. 4).
- Step 7:** Slide the brace on Stinger™ tip and secure with clip. Use 1/2" alloy screw and lock nut to secure Stinger™ brace to rear bumper (Fig. 2).
- Step 8:** Use MIP fuel tubing for the pressure line. Connect fuel tubing to pressure fitting on the gas tank, and push the other end of the fuel tubing into the hole in the Stinger™ about 1/2 inch (Fig. 3).

Fig. 3

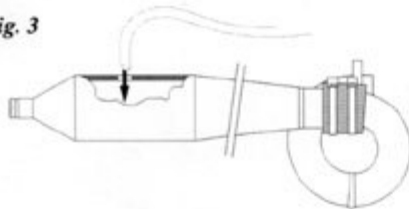
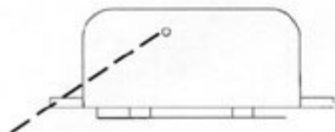

Fig. 4



Hole location for rear Stinger™ brace.

Traxxas:

Part #	Description	Price
3022	360 Stinger Kit for Nitro Rustler	55.00
3016	Nitro Rustler shock tower	12.50
3004	Stinger™ Pipe (purple)	16.95
3005	360 Header (purple)	24.95
3007	Header Hose & Ties	3.95
3029	Fuel Tubing 2ft.	2.75

Send a SASE for an MIP Catalog.

[RETURN TO LIST OF INSTRUCTION SHEETS](#)