

MAXX Performance CVDs

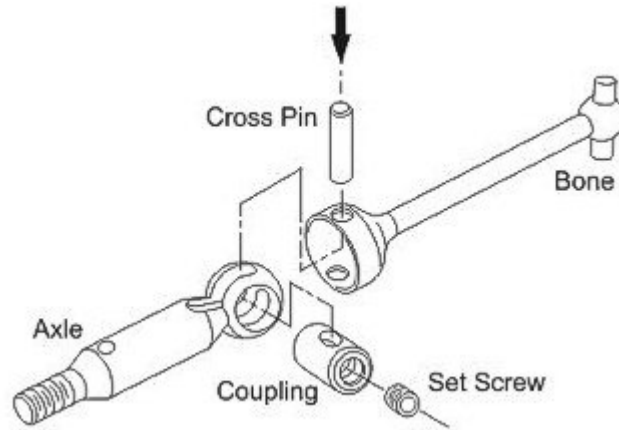

Assembly

Please Follow Instructions Completely:

1. Spread a thin layer of MIP CVD™ lube on couplings, and insert into the axle.
2. Slide completed axles into the bone with the cross holes aligned.
3. Insert the cross pin and make sure it is evenly spaced on both sides of the bone.
4. Angle and turn CVD™ so the set screw can be installed with the supplied allen wrench. Always use the included MIP Thread Lock on the set screws and allow them to dry for 24 hours.

Installation

Front and rear CVD™s:

1. Remove the stock plastic slider drive axles and yokes from your MAXX truck.
2. Install the MIP steel drive cups onto the transmission output shafts using M5 x 5 set screws and MIP Thread Lock. The drive cups and hubs are a precision fit so they may be snug on the output shafts. If needed you should carefully tap them on.
3. Slide completely assembled CVD™ through the bearing hubs and inset axle cross pins, hubs, and wheels same as stock.

BE CAREFUL NOT TO OVER TIGHTEN THE WHEEL NUTS AND BIND THE AXLES.