

ASSOCIATED RC300 INSTRUCTIONS

Your ASSOCIATED RC300 1/8 scale gas powered radio controlled race car, is the best car available anywhere, and will give you race winning performance and a very precise handling car which is fun to drive. Part of your enjoyment with the car will be in assembling the kit. Please take your time, follow the instructions and do the very best job you can in assembling the car. The job you do assembling the car will greatly influence the reliability of the car and how easy it will be to drive. **IMPORTANT** - the parts and hardware are all packaged for easy, orderly assembly. **DO NOT** mix parts from one bag with another. Keep parts in their proper bags until you need them.

We'll start by assembling the rear end of the car. Refer to photo #3 & 5. Take the R.H. rear axle bearing block #2627, lay it down flat on something solid and lightly tap the two 3/32" pins #2616 into the block. Be careful and make sure they go in straight. If you're running a rear mounted muffler, take the L.H. bearing block #2628 and file the forward corner as shown in photo #3.

Install the 2 rear axle ball bearings into the 2 rear axle bearing blocks. These go in from the outside of the block. You should be able to push these in with your fingers. You can coat the outer diameter of the bearings with Loctite #271 or contact cement, before pushing in the bearings, which will keep the outer diameter of the bearings from turning in the bearing blocks and eventually becoming loose in the hole.

Install the 2 bearing blocks with the 4 10/32 hex head bolts to the rear chassis pod plate. Refer to photo #3. Slip the rear axle into the R.H. bearing, and over to, but **NOT** into the L.H. bearing. **GENTLY** move the L.H. end of the axle forward and then towards the rear of the car noting the position of the end of the axle in relation to the center hole in the L.H. bearing. If the end of the axle moves as far forward as to the rear of the bearing hole, then the R.H. bearing block is centered. But if, for instance, the end of the axle moves farther towards the front than the rear, then the 2 bolts holding the R.H. bearing block will have to be loosened, the block moved and held in place with your hand and the 2 bolts retightened. Then recheck the centering. When the R.H. block is centered, repeat the procedure for the L.H. block. When both blocks are centered correctly, the axle will slip thru both bearings so easily that if you turn the rear pod sideways, the axle should fall out of the bearings by its own weight. This will give you a very free running axle with no drag.

Install the L.H. and R.H. engine mounts #2502 on the engine. The RC300 kit is normally supplied with engine mounts and flywheel for the K&B 3.5 (.21 cu. in.) engine. Refer to photo #8. After the engine mounts are installed we recommend sanding the bottom of the mounts so they are perfectly flat. Photo #9. This allows installation of the engine in a distortion free mounting, which increases horsepower and reliability. Use 240 or 360 grit sandpaper like Wet or Dry type. Hold the engine near the engine mounts and in a circular fashion, sand the bottom, as shown, until they are flat. The sandpaper must be laid flat against a very flat surface, such as a piece of glass, a table top, etc. Clean off all sandings being careful not to get any in engine.

Install the clutch assembly. The clutch assembly instructions will be on a separate sheet in the back of this booklet. Photo #8. The clutch bell is installed with 2 flanged and 1 unflanged ball bearings. The clutch bell should slip easily over the clutch shoes. If not, the clutch shoe rolled ends may have to be closed a little more with a pliers.

Refer to photo #5. Take the aluminum brake roter/gear hub #2622 and tap in the 2 1/8" pins. They should stick out approx. 1/8" on both sides of the hub as shown.

Take the 2 aluminum rear wheel hubs #2624 and install them on the 2 rear wheels. Do not completely tighten the 4 mounting screws yet. Refer to photo #4. Slip the L.H. wheel and hub on the axle end that has one flat ground on it. Slip the wheel on far enough so the axle end is even with inside wheel hub. Tighten the large 1/4 - 20 set screw and then the 4 wheel mounting screws. Be sure **NOT** to **OVERTIGHTEN** the 4 screws. They only have to

be lightly tightened.

Refer to photo #3. Slip the 2 wing tubes #2201 in the bearing blocks and lock in place with the 2 1-/32 set screws.

Refer to photo # 6 & 7. Slip the disc brake cam #2612 into the rear chassis pod plate. Slip the upper aluminum disc brake bracket #2614 over the wing tube and brake cam and install the 10/32 hex head bolt. Slip the axle with the L.H. wheel on it through both rear axle bearings. Now slip the gear hub on. You'll notice the gear hub will not clear the disc brake cam. The exact point is shown in photo #7 with the pencil. Be sure the brake arm #2613 is in the brake cam so the brake cam is in the correct position. Mark the cam where it must be relieved. The cam will have to be relieved so the brake arm can rotate forward as far as the wing tube. Remove the cam and grind the clearance with a bench grinder or Dremel.

Remove the gear hub from the axle and install the plastic gear #2619 on the hub with the 2 flush head screws as shown in photo #10.

Refer to photo #5 & 13. Install the 2 disc brake shoes on the pins and reinstall the disc brake cam, the aluminum bracket and the cam arm. Then slip the disc brake rotor in, from the front, between the 2 brake shoes.

Slip the gear and hub back on the axle, as shown in photo #13. The disc brake rotor must line up with the 2 pins in the gear hub. DO NOT try to force the rotor onto the hub. If you cannot get it aligned properly, remove the hub and rotor and slightly enlarge the holes in the rotor until it slides on the pins easily. Re-assemble the rotor, gear and hub.

Note: Some kits will come with the fiber disc brake rotor #2610 as shown in Photo #5 Other kits will have a ground steel disc brake rotor. If your kit has the steel disc rotor you will have to glue the asbestos lining supplied, to the disc brake shoes #2611 - photo #5. The asbestos will be glued to the sides of the shoes that contact the rotor. Rough up the shoes with sandpaper and use a good quality contact cement such as 3M #8001 available in hardware stores.

SPECIAL NOTE: If you run in areas with solid retaining walls where you're likely to bend the wing tubes, it would be a good idea to add an 8/32 flathead screw in the #2614 aluminum bracket see photo #7. Add this screw a little ways to the rear of the R.H. wing tube thru the #2614 bracket and into the R.H. #2627 bearing block. In the event you bend the R.H. wing tube you could change the brake adjustment without this added screw.

Set the engine on the power pod and install the 4 10/32 hex head bolts from the bottom of the pod plate - but only FINGER tight, so the engine can slide forward and backward in the slotted holes. Check the clearance, as shown in photo #10, between the clutch bell gear and the plastic spur gear. There needs to be a very small clearance between the teeth of the 2 gears. **THIS IS IMPORTANT.** You should have about a paper's thickness clearance between the two gears. When you have the correct gear fit, tighten down the 4 motor mount screws.

Refer to photos #11, 12 & 14. These are possible interference areas. Photo #11 shows possible interference between the #2614 aluminum disc brake bracket and the gear. If the gear is touching the bracket, the bracket must be filed for clearance. Photo #14 shows a point where the #2610 disc brake rotor might rub on the #2614 aluminum bracket. If so the aluminum bracket must be filed at this point. In photo #12 check the clearance between the disc brake rotor #2610 and the engine flywheel #853. This clearance must be checked with the BRAKE ON. It doesn't matter if the brake rotor touches the flywheel if the brake is off. While the car is running the centrifugal force will keep the rotor away from the flywheel. If the rotor touches the flywheel when the brakes are on, install one thin axle

washer on the axle between the gear hub #2622 and the R.H. ball bearing.

When you have all the clearances correct in photo's #11, 12 & 14, put the brake arm #2613 in a released brake position. If the forward inside corner of the disc brake cam #2612, starts to engage the brakes again, as you're in the extreme brake release position, then remove the disc brake cam #2612 and refer to photo #6 and file the appropriate position, then remove the disc brake cam #2612 and refer to photo #6 and file the appropriate inside, FORWARD corner flat. Reinstall brake assembly. Install R.H. wheel. Install wing tube collars on wing tubes.

Refer to photos #16 & 18. Take the L.H & R.H. plastic suspension arms #2650 and sand the bottoms flat as shown in photo #16 on sandpaper. You can set them on the chassis plate and check them for flatness. Make sure the sandpaper is on something flat.

Refer to photo #17. The #2652 steering blocks are heat treated to a hard condition. Sometimes this will cause a scale on the steering blocks. This can cause interference in the 4/40 threaded holes, so be VERY CAREFUL in this next step. Take the 2 steering blocks and screw the four 4/40 allen screws into the steering blocks, but WITHOUT the two #2653 steering arms. Check to see if the screws will go into the blocks far enough to tighten the steering arms. If any of them do not appear to go in far enough, DO NOT - repeat - DO NOT try to force the screws in, you'll end up breaking the screws off. Also DO NOT try to force a tap in because you'll also break it off. Just put the screws in until they bottom out. One or two might be too long. If so, simply cut or grind the screws shorter. When you have them the correct length, install the #2653 arms on the #2652 steering blocks as shown in photo #17. This photo shows the R.H. block.

Refer to photo #17 & 18. Take the #2651 kingpins and slide them into the 1/4" holes in the steering blocks to check for fit. If they do not slide in easily, clean the scale out of the 1/4" holes in the steering block. You can do this easily by wrapping some sandpaper around a 10/32 bolt or a wing tube and sliding it in and out of the block. 600 or 400 grit paper would be good for this. When the kingpins fit the blocks freely, clean all parts. CAUTION - Do not grip the kingpins with a pliers as they are extremely hard and you will break them.

Refer to photo #18. Use a snap ring pliers, available in hardware stores and put one of the #858 clips on each of the king pins. Next, you can use oil, but a light white grease is better. This is also available in hardware stores, in small tubes. Put a light coat of grease inside both 1/4" holes in the steering blocks #2652, and a light coat of grease on the kingpins #2651. As shown in photo #18, install the kingpins in the suspension arms and the steering blocks. Support the bottom of the suspension arms with a socket or something similar. If you have the parts aligned properly, they will go together quite easily. Possibly just by pressing with your finger, or with a VERY LIGHT tap of a small hammer. Do not pound hard on the kingpin. It means you don't have the parts aligned properly. When the kingpins are installed wipe off the excess grease and install the other two #858 clips on the bottom.

Install the #2650 suspension arms on the #2649 chassis plate as shown in photo #20. Use the 2 shorter 10/32 flat head screws in the rear holes.

Assemble and install the #2525 servo saver and #2530 tie rods as shown on the instruction sheets in the back of this booklet.

Install the front bumper #2659, using the shortest flat head screws and locknut. Install the #2658 body mounts on the #2657 body mount support, then install the body mount support on the suspension arms with locknuts.

Photo #21. Install the front chassis plate to the rear pod plate, as shown, using the aluminum radio tray mounts, flat head screws and nuts. Install the front radio tray aluminum mount. Refer to photo #19 & 26. Install the front tires. ALWAYS oil the front stub axles

before installing the wheels. This is important.

Assemble the radio tray as shown in the instructions in the back of this booklet, including the fuel tank.

Assemble the radio tray to the chassis and hook up all linkages as shown, and according to the linkage instruction sheets.

MOUNTING TIRES: The front and rear wheels are made of nylon. When you've worn the tires down and they need replacing, simply soak the tires and wheels in lacquer thinner, overnight. The next day you will be able to peel the rubber off the wheels with your fingers. We strongly recommend that you rough up the outside of the wheels with a file or something similar. The glue will stick better on a rough surface. Also, if you're using the molded front tires the smooth inside of the tire must also be roughed up for the glue to stick to it. We recommend using the 3M brand #8001 Super Weatherstrip Adhesive, which comes in a tube and is available in hardware stores. Apply a coat of glue to the wheel and another coat of glue to the inside of the tire. Let the glue dry for 2 hours. Do not let it dry overnight. After 2 hours, either brush a coat of lacquer thinner on the wheel and tire and slip them together, or dip the wheel and tire into lacquer thinner, pull them out and slip them together. Leave the tires dry overnight and then they can be trued on a drill press, with sandpaper glued to a flat piece of wood, or on a lathe or grinder. Make sure each pair of tires is the same size.

ENGINE TUNING TIPS

In every beginner's mind there is the question of which is the best engine, fuel, plugs etc. We'll try to answer as many questions as possible that confronts every beginner. In the United States, the K&B 21 is the most popular engine. In its stock form it gives sufficient power for racers. Throughout the world other engines are also used, such as Supertigre, OPS 21, Webra and Enya. Our rules limit us to a .21 cu. in. or 3.5 cc size engine. We recommend the K&B 21 because as a beginner it will give you all the horsepower you can handle for awhile. There are other advantages to using the K&B 21 if you live in the U.S.A. The engines and parts are readily available everywhere. Also there are many items made just to fit this engine. Besides the McCoy hop up parts, Associated makes special carb air filters, which are a must for long engine life as well as a head heat sink which is also a must. McCoy makes high compression heads.

Whatever you do, never run your car without a heat sink or air filter. Without a clean heat sink, the engine will run too hot and lose compression. You'll probably run on quite a few different tracks, and no matter how clean they look, they're all too dusty. An engine run on a track with no air filter will have a life of approximately 1/2 hour, and we're sure you want yours to last much longer than that. Another tip is to take the air filter element and soak it with WD 40 or some light oil. This helps to catch the very fine dust which acts like an abrasive and will cause your engine to lose compression.

Your engine will run with a stock carb, but it will run twice as good with a Perry carb. It'll idle better, accelerate faster, give you a higher top end, and if that isn't good enough, it'll also give you more mileage. It should be on your "must" list. Perry makes two models that are widely used in R/C cars. The most popular for beginners is the Perry for the Veco 19. To install, simply loosen the two screws holding in the stock carb, twist and remove the old carb. The Perry will fit right in the same size hole. The second popular Perry carb used is the model for the K&B 40. This has a larger throat, allowing more air to enter the engine, giving more horsepower, making it popular with the expert class racers. Having a larger throat, it's necessary to bore out the crankcase to install this carb, so I wouldn't worry about it if you're a beginner. The best type air filters are the paper element type. They keep all the dirt out.

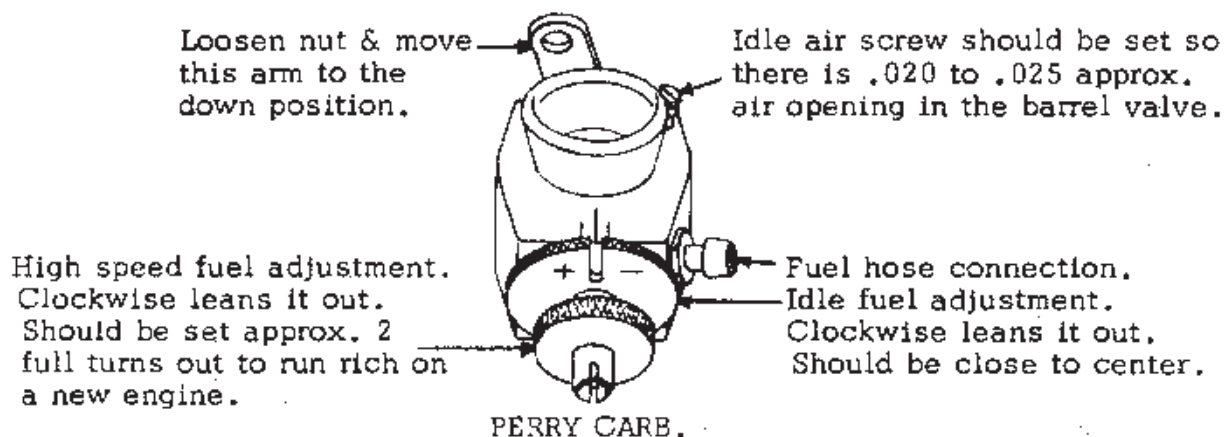

We recommend you either use G.E. or Dow Corning Silicone Rubber as a seal when installing the new carb. It will help to give a smoother idle. A lot of racers like to epoxy in the Perry carb because it's made of plastic and you can't tighten down hard on the mounting set screws because you'll choke off the throat of the carb. Most any type of epoxy will do, but if you can find Epoxy-Patch No. 1C White, in an industrial supply store. It's better suited to this job. With regular epoxy you'll have to be careful because it could run down into the crankshaft. But the Epoxy-Patch is thick and will stay where you place it. Although the Associated air filter is primarily made for the Veco carb, with a small amount

of filing of a notch to clear the air adjustment screw, it will fit, so be sure to use it.

Take a trip to your hobby store and pick up a couple of spare Glo plugs. Either the K & B or Fox R/C Long Reach is best. You'll need a 1 1/2 volt battery, wire and clips to ignite the Glo plugs, and a large fuel filter. You should also get a starter motor as used on airplanes, but with an adaptor to start R/C cars. Your hobby shop should have several to choose from. You'll also want some fuel to break in your engine. You should use K & B 100 fuel or an equivalent type fuel that has no more than 10% nitro and at least 20% castor oil. Do not use any fuel that contains synthetic oils. Synthetic oils work great in planes and boats but they make the engines run too hot in cars. You'll burn your new engine out. Don't worry about higher nitro fuels or hopped up engines until you're an experienced driver. These will only get you in trouble if you're a beginner.

We have run stock Veco 19 engines (stock except for a Perry carb) in practice and weekly racing for over a year and then retired it, but it was still running strong. And hopped up, chrome liners in a Veco 19 will last at least 6 months, without pulling the engine apart. This is to give you an idea of what you can and should expect from your engine if you pay attention to the do's and don'ts we're telling you.

One of the most critical times in an engine's life is during the break-in period. Too many guys can't resist the temptation to take their new engine out to the track, lean it out to hear it sing, and then wonder why, after an hour's running, they've lost all compression. The pistons are ground and the cylinders hone to as fine a finish as practical. But lapping or polishing would put the cost out of sight. There are many ways to break an engine in, such as bench running with a propellor, which is the standard method used for airplanes. This works great, but you can do as good a job in your car. The important thing to remember is to run it as blubbering rich as you can for at least 15 minutes the first time you run it. You'll be learning how to drive the car, so you'll be running slow so leave it running on the rich side as you learn to drive the car. As your driving gets better you can gradually start to lean it out.

You'll find that the more you run your engine, the faster it will begin to idle as it starts to break in, so you'll have to re-adjust the idle settings a few times. If it's idling too slow it can be either too rich or not getting enough air. On the Perry carb if it's too rich, turn the idle disc just a very few thousandths to the right (clockwise) until the idle cleans out. If it's not fast enough, turn the air screw on top of the carb in about 1/4 of a turn. You'll have to work back and forth between the fuel idle disc and the air screw until you get your desired idle speed, because both of these settings affect each other and they must work together. But be careful, you don't want your idle too fast or you'll burn out the clutch lining. It just has to be fast enough to keep idling smoothly.

When you feel your driving's up to it, you can start to lean out the main fuel adjusting screw. Turning it clockwise leans it out. Your car should have been sluggish and blubbering in a 4-cycle going down the straightaway. Turn the screw in about 10 degrees, make a lap around the track and see if it's still blubbering. Repeat this procedure until the blubbering stops. It should now be running nice and clean and just a little on the rich side. Leave it like that and go out and beat your competition.

CHASSIS TUNING TIPS

You've driven the car enough now to break the engine in and you probably feel like you want to start getting around the track faster. The biggest mistake made by most R/C car racers is that they believe they need the maximum amount of steering from the car to be able to get around the track. Actually, the opposite is true. The idea is to set up your car to have the least amount of steering you need to get around the track smoothly. This is very important. Your car should be set so the Steering Servo Saver linkage is in the furthest outside hole. When you feel your driving has improved enough, move the linkage, one hole at a time, towards the inside. Drive the car and see if it's helping you to get around the track faster, or it's making you spin out more. Increase or decrease the amount of steering until you find the correct combination for you.

Check the "tweak" in the chassis. This must be done with two rear tires of the same diameter and two front tires of the same diameter. Use a very flat surface, such as a plate of glass. Take a piece of 3/8" tubing and roll it under the right hand front wheel. Refer to the drawing on the next page. Note how far the left hand wheel comes off the glass. Then do the same procedure to the other wheel. Generally, one wheel will raise higher off the glass than the other. If this is the case, the chassis is "tweaked" to one side or the other. By holding the front and rear wheels, you should be able to "tweak" the chassis back to square.

We've found that 3 1/4" dia rear tires give the maximum traction per rubber weight. As the diameter goes down, the car becomes harder to drive. For the important races, you should use 3 1/4" rear tires and then, as they wear down too much, use them for practice. You also want the front tires the same size, left and right, between 2 3/4" and 3". Most racers will switch their tires from left hand to the right hand side, to keep wear even.

Drive the car around the track. Each track has its own conditions, so we can't give you the perfect setup for your track, but we can help you to find it. Generally, the most common complaint is the car spins out too easily (oversteer). Check to see if it spins out easily going left as well as right. If it does, cut down on the steering travel as explained earlier. Keep cutting down on the steering until the car is impossible to spin out, but now it just won't turn quite sharp enough to make the corners fast enough (understeer). Add just enough steering back to get around the track fast, but no more.

Another cause of spin-outs is the chassis is tweaked too much to one side or the other. Let's say turning to the right, the car spins out easily and yet turning to the left, the car is almost impossible to spin out. It's also very "squirrely" coming out of the corners. If it spins out turning to the right, add a couple washers between the chassis plate and the cross arm, on the right-hand side. Refer to the drawings on the next page. Run the car again and see if it's okay, or if you might want to add another washer or maybe take one out. Your car can also be purposely "tweaked" to one side or the other to aid in handling, such as in an oval race. It's possible to tweak the chassis so that you can make the sweepers fully punched. Remember, the more time you spend setting up your car, the better driver you'll be and the more races you'll win.

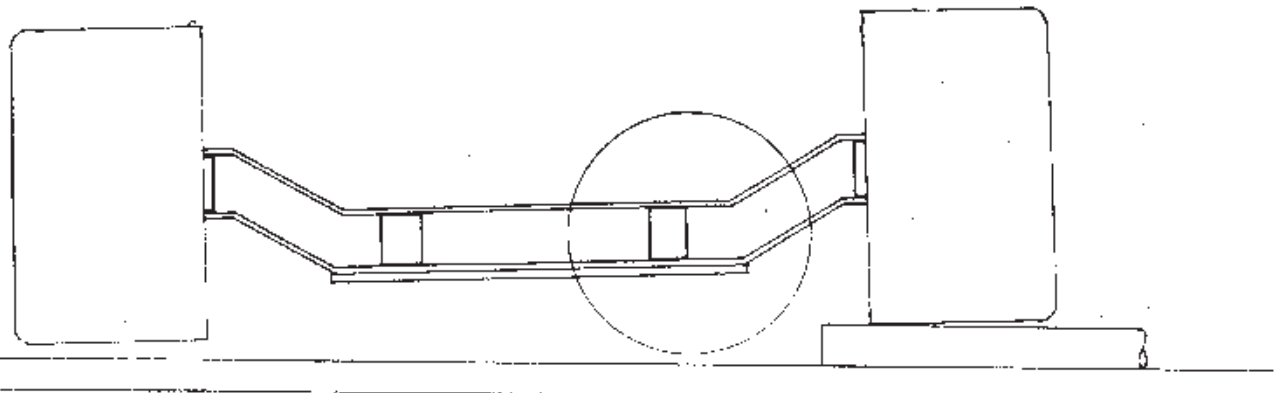

LINKAGE

Refer to photo page, and Radio Tray Mounting and Bellcrank Assembly drawing. The photos show the throttle linkage at idle position and the drawings show the linkage at full throttle position.

Set the servo arm and bellcrank arm so they're parallel. Measure the distance between the 2 arms and bend a "U" in one of the "Kwik links" to fit this measurement. Install the Kwik link.

The throttle arm on the Perry carb shown should be on the bottom and set so it moves an equal amount to the left and right of the carb shaft. Attach return spring.

Turn your radio on so the throttle servo moves to idle position. Turn the radio off. NOTE: Some servos will move in the opposite direction as others. If your idle position is the opposite of the idle position shown, simply remove the output arm and rotate it 180° degrees. Your throttle linkage will simply then hook up on the R.H. side, instead of the L.H., and your brake will hook up on the L.H.

Take the short piece of 1/16" piano wire, put a 90° bend in it for the carb arm and measure and bend the other end so it lines up with the outer hole of the bellcrank. Install wire with red keepers.

Measure, bend and install brake 1/16". There will be a slight drag when the wheels are turned forward and almost no drag when the wheels are turned backward. Make sure you have that 1/16" clearance between the brake band and releasing collar. Final brake adjustment must be done at the track. The ideal adjustment, which is set by increasing or decreasing the spring tension with the rear collar, is to have the brakes slow the car rapidly, without locking up the brakes and spinning the car out. This adjustment may change in the beginning until the 2 brake linings "seat" to each other. Then the brakes will remain uniform.

Turn on the radio again. While holding the throttle control wide open, turn off the receiver switch so the throttle stays wide open, then turn off the transmitter. Spin the rear wheels forward. They should spin freely with absolutely no brake drag. If the brake drags it will cut down on your speed and burn out the clutch. Adjust the 1/8" wire where it goes in the bearing block, or change the bend on the brass strip so there is absolutely no brake drag at full throttle.

Next hook up the steering "Kwik link" linkage. But first, drill out the holes in the Steering Servo Saver with a #48 drill. The holes were made for 1/16" wire and the Kwik link is slightly larger. You may have to reverse the arm on the servo if the front wheels turn on the wrong direction. Start with the linkage in the outer hole in the servo arm and the outer hole in the servo saver arm.

Turn on the radio. Check to see if the front wheels are "centered" to the chassis. If not, adjust the linkage.

With the radio still on, check to see if the carb closes (actually it should "close" with about a .020 air gap for idling). Actuate the throttle fully open with your transmitter, and see if the throttle fully opens. Adjust your linkage so the carb fully closes and fully opens with your transmitter.

RADIO MOUNTING TRAY TEMPLATE

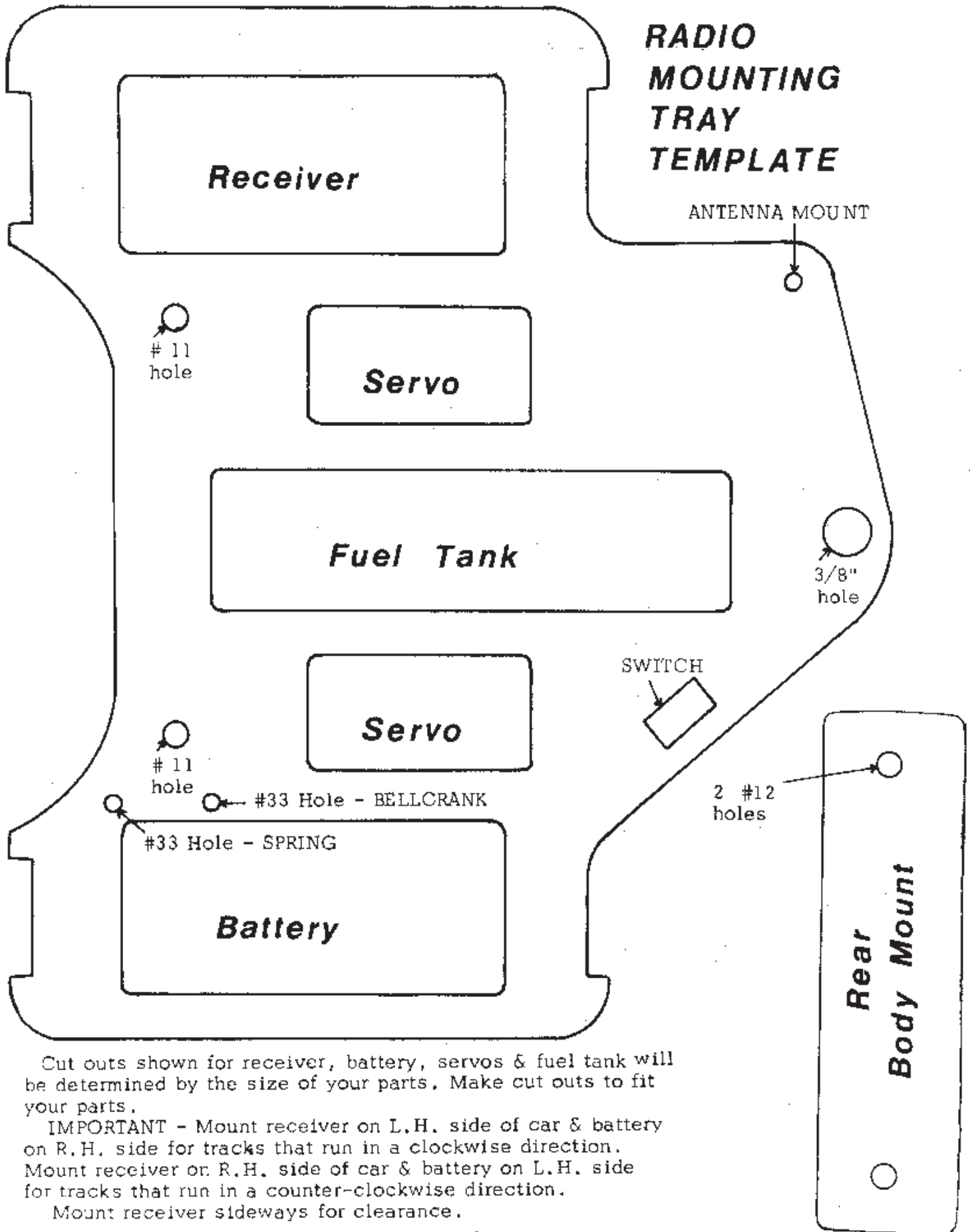

Cut outs shown for receiver, battery, servos & fuel tank will be determined by the size of your parts. Make cut outs to fit your parts.

IMPORTANT - Mount receiver on L.H. side of car & battery on R.H. side for tracks that run in a clockwise direction. Mount receiver on R.H. side of car & battery on L.H. side for tracks that run in a counter-clockwise direction.

Mount receiver sideways for clearance.

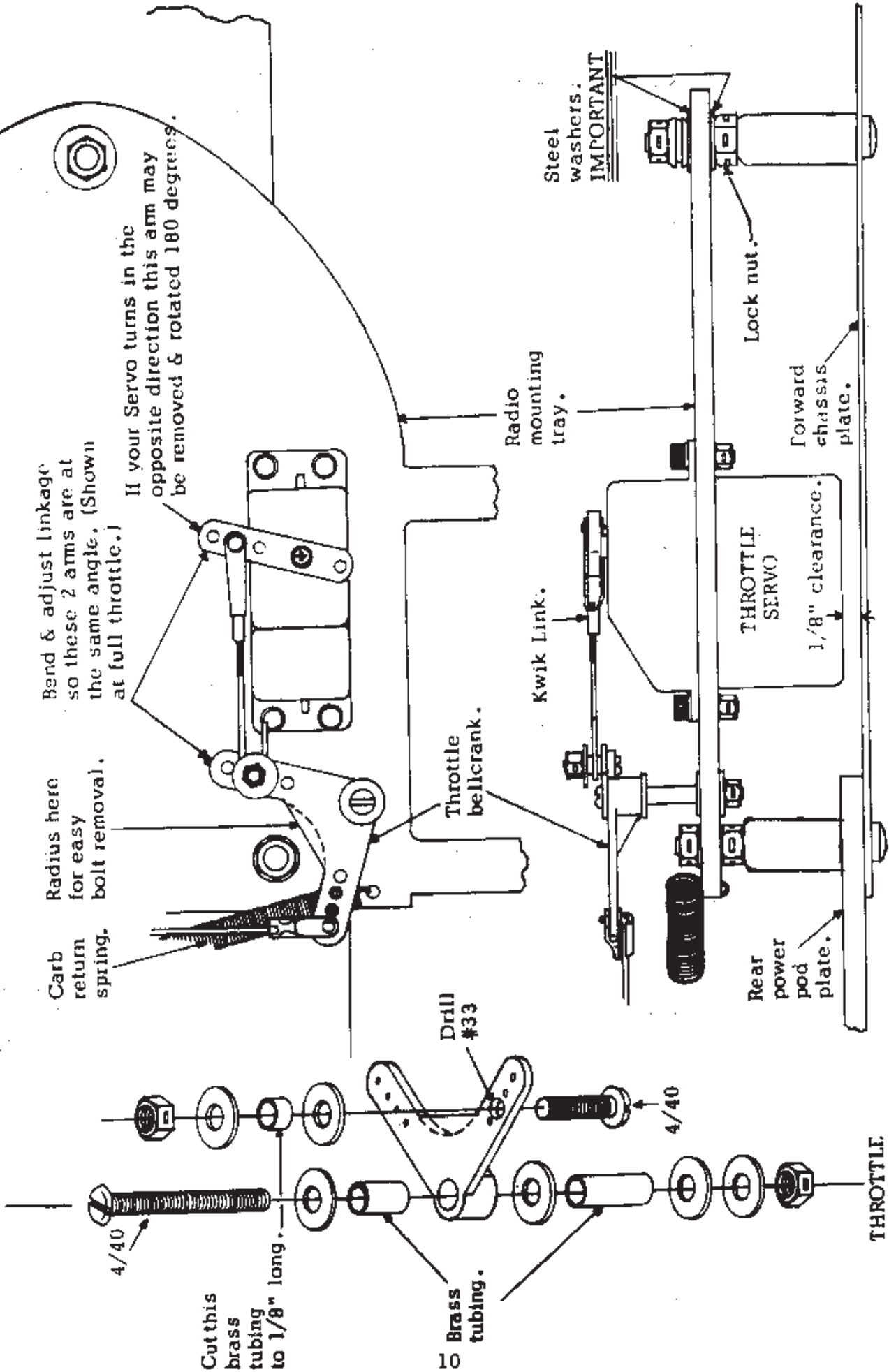

Bend & adjust linkage so these 2 arms are at the same angle. (Shown at full throttle.)

If your Servo turns in the opposite direction this arm may be removed & rotated 180 degrees.

Radius here for easy bolt removal.

Carb return spring.

Throttle bellcrank.

Radio mounting tray.

Kwik Link.

THROTTLE SERVO

1/8" clearance.

Rear power pod plate.

Forward chassis plate.

Lock nut.

Steel washers. IMPORTANT

4/40

Cut this brass tubing to 1/8" long.

10 Brass tubing.

Drill #33

4/40

THROTTLE BELL-CRANK ASSEMBLY

RADIO TRAY MOUNTING & BELL-CRANK ASSEMBLY DRAWING

RC 300

FUEL TANK INSTRUCTIONS

Assembling the fuel tank is relatively easy with the correct tools and instructions. The best soldering iron is an Ungar #777 with a #4033 tip, and the best solder is Stay Brite Silver Solder. These are available from hobby stores or hardware stores.

A word of caution - Stay Brite Silver Solder uses an acid flux. Treat it as an acid. It is very corrosive and will rust out parts. Water will neutralize the acid. Do not use on electrical connections. Also - do not use rosin flux type solders to assemble this tank.

The tank is made from the Johnson fuel tank kit #SP1. The "Flip Top" fuel filler cap is part #SP61. A 1/2" brass tube can also be used for the fuel filler using the Don's rubber fuel tank filler cap #SP3.

First, drill two 1/8" holes in the wider of the tank halves for the fuel pickup line and the muffler pressure line, as shown. Then drill and enlarge the hole to fit the flip top cap. Slip the cap in the hole, and then mark the cap to the same upside down "V" shape of the tank roof and cut the cap bottom to this "V" shape.

Refer to Fig "B". Make a box out of .015 brass. The box is 1" long X 1/2" high X 3/4" wide. The top and both sides are one piece, with one other piece used for the front. The back side is OPEN. Solder the front end to the top and sides. Then drill a 1/8" hole in the front end of the box as shown in Figure "D".

Thoroughly clean out the tank halves with acetone, MEK, lacquer thinner, or whatever you have. Form the fuel pickup line as shown. If you're using a large bore carb, form the vent-muffler line as shown. If you're using a smaller carb, such as the Perry 19 muffler pressure is NOT required. Refer to figure "A", #2 and bend this line straight up. Refer to Figure "C", #5 - the vent line should be 1/2" up from the tank bottom, and should be on the R.H. tank wall as shown in Figure "D", #8.

Solder all parts together in the rear tank half. Flush the rear tank under running water for 5 minutes. Solder the 2 tank halves together. Make the mounting brackets out of brass and solder them to the tank as shown in Figure "A" and "C". Flush the tank inside and out again under running water.

Hold the tank under water in a pan of water. Seal the muffler tube end with your finger and blow through a piece of fuel tubing attached to the fuel line. This will show any tank leaks. Wherever bubbles show up, you'll have to resolder. Shake all the water out of the inside of the tank. Half fill the tank with fuel and slosh it around, then empty it out. This will lubricate the inside of the tank and keep it from rusting.

VERY IMPORTANT - A good high quality inline fuel filter must be used between the fuel tank and carb and this filter must be cleaned regularly. Some racers use a Du Bro clunk type porous bronze filter #161 that is placed inside the box in the fuel tank, at point #6, Figure "C". Either method is O.K.

FUEL TANK

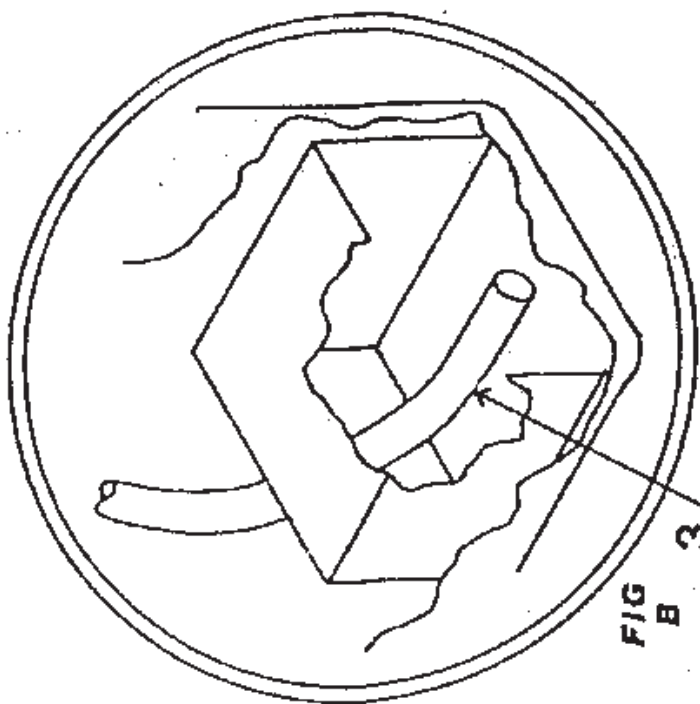
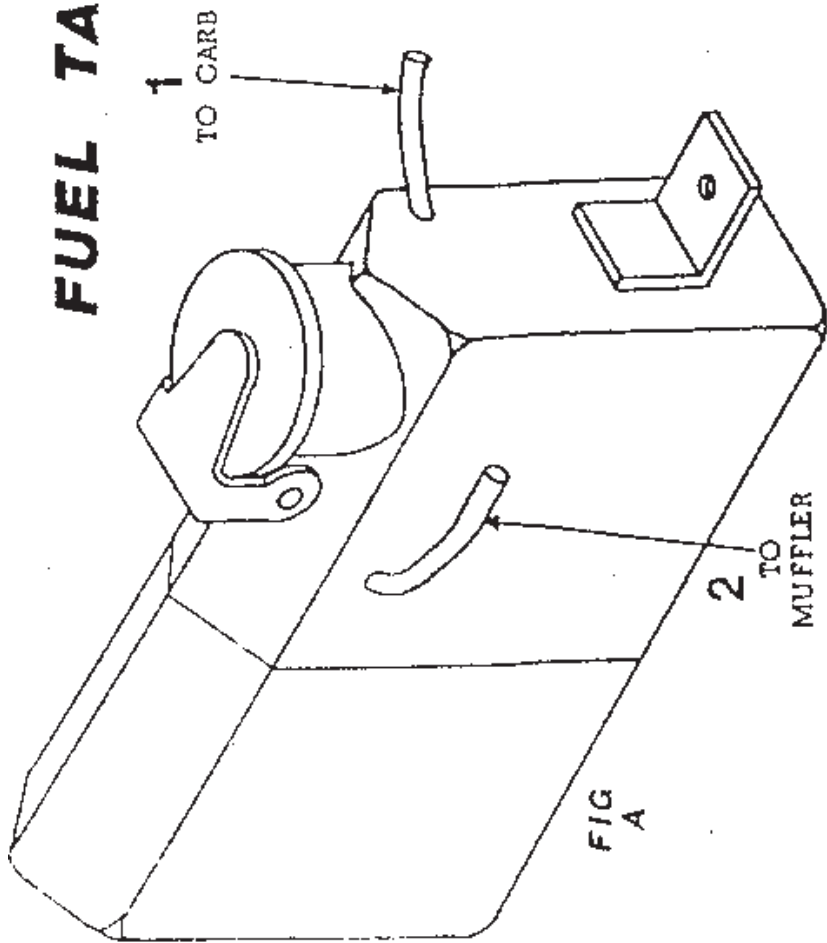

FUEL PICKUP

FIG B

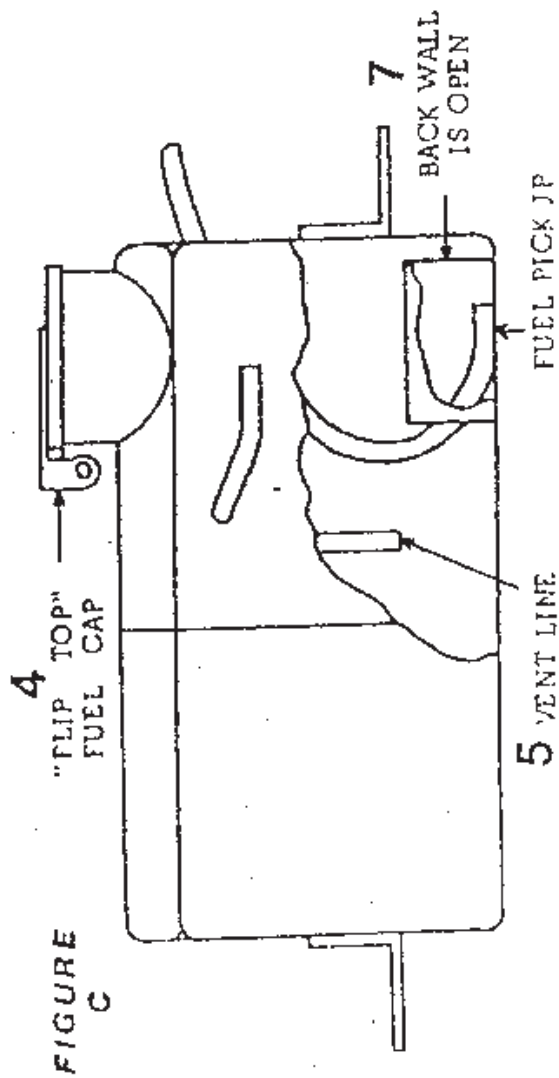

FIGURE C

"FLIP TOP" FUEL CAP

5 VENT LINE

7 BACK WALL IS OPEN

FUEL PICK JP

4

5

7

8

FIG D

8

VENT LINE

8

VENT LINE

8

RC 300 RC 200 SERVO SAVER 2525

TIE ROD ASSEMBLY 2530

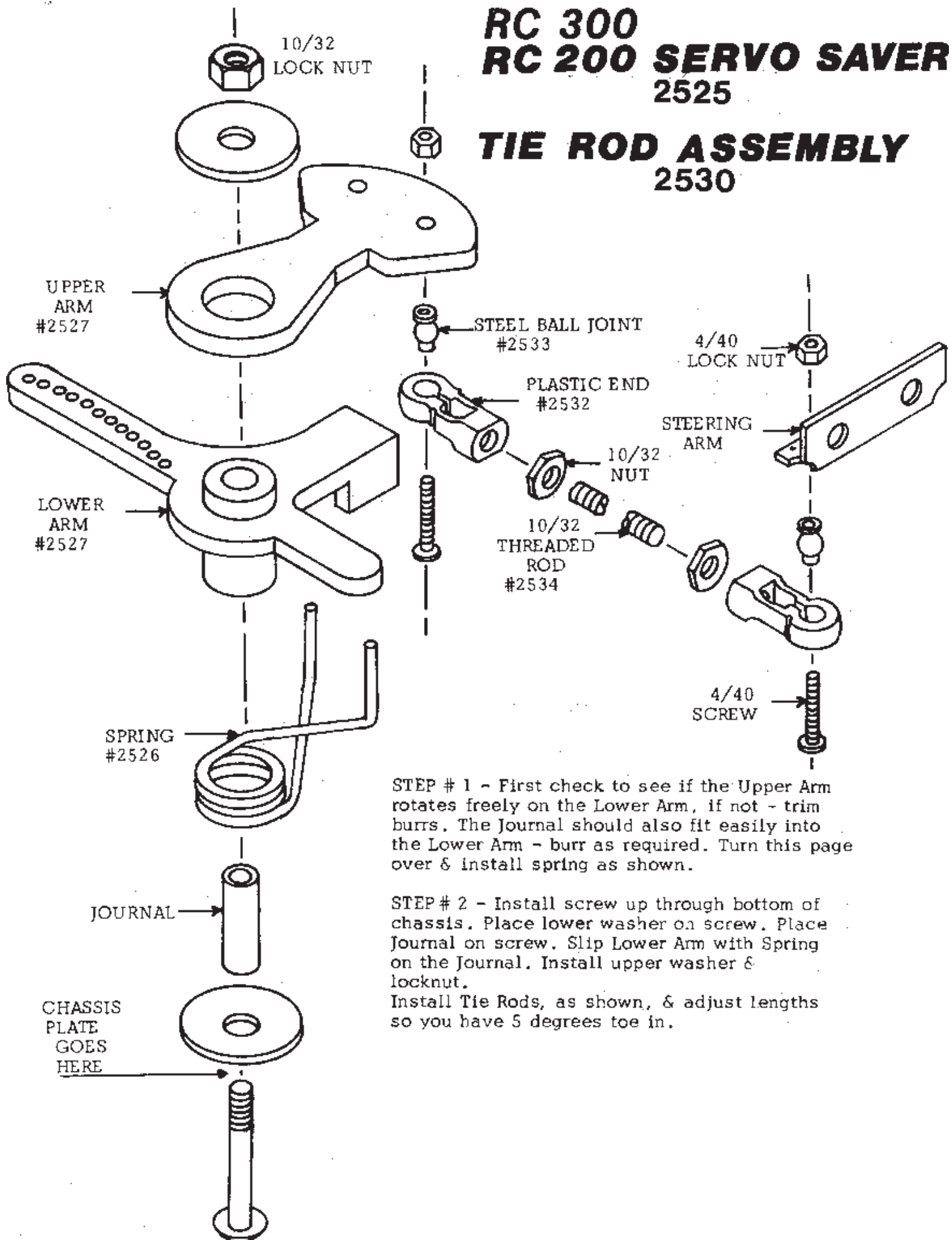

STEP # 1 - First check to see if the Upper Arm rotates freely on the Lower Arm, if not - trim burrs. The Journal should also fit easily into the Lower Arm - burr as required. Turn this page over & install spring as shown.

STEP # 2 - Install screw up through bottom of chassis. Place lower washer on screw. Place Journal on screw. Slip Lower Arm with Spring on the Journal. Install upper washer & locknut.

Install Tie Rods, as shown, & adjust lengths so you have 5 degrees toe in.

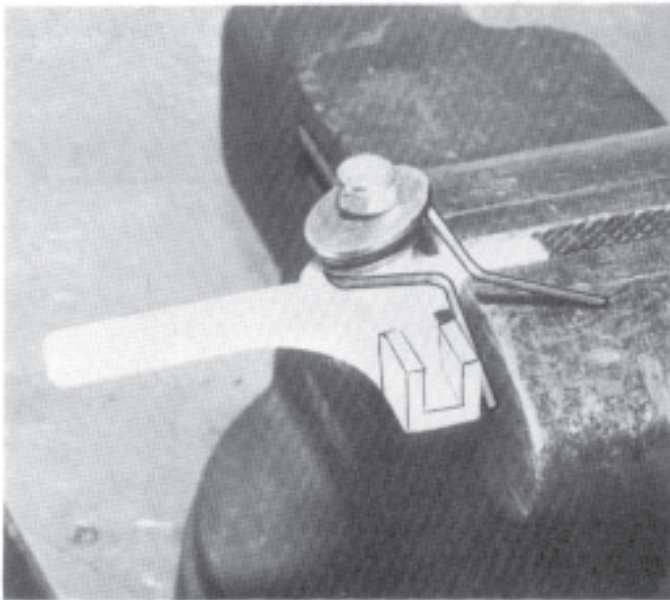

#1 The easiest way to install the spring on the Lower Arm is as shown. First - install the Servo Saver mounting screw in the TOP of the Arm, then turn the arm upside - down. Next - slip the spring on, to the right. Next - DO NOT put the Journal on, but put one Washer on & put the Nut on. ONLY tighten the Nut about 3 turns - NO more. IT MUST BE LOOSE.

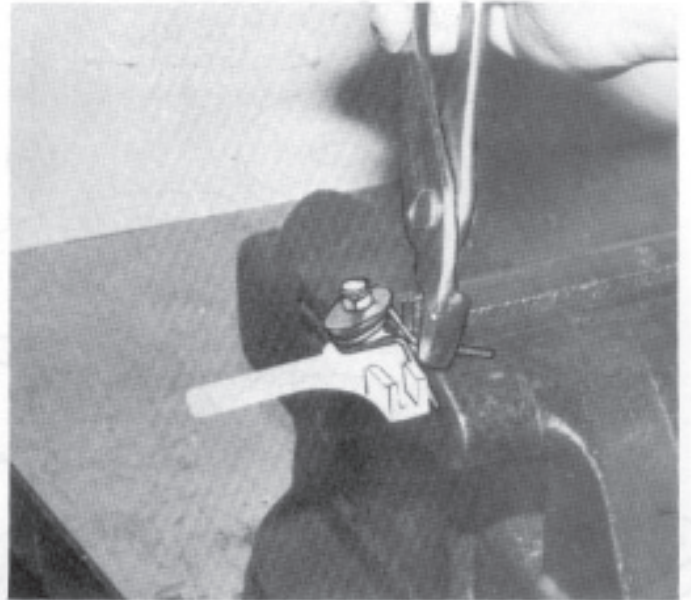

#2 The BEST way to install the Spring, is to hold the short part of the Lower Arm in a vise, as shown in photos #1 & #2. Using a pliers, take hold of the spring leg - to your right - lift it up & cross it over the Saver center to your left side.

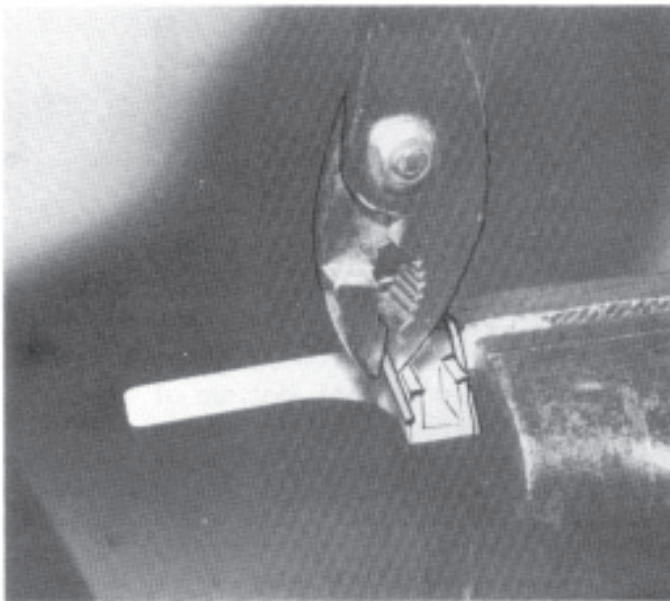

#3 Keep your fingers away from the spring, until you have completed moving the spring to your left side.

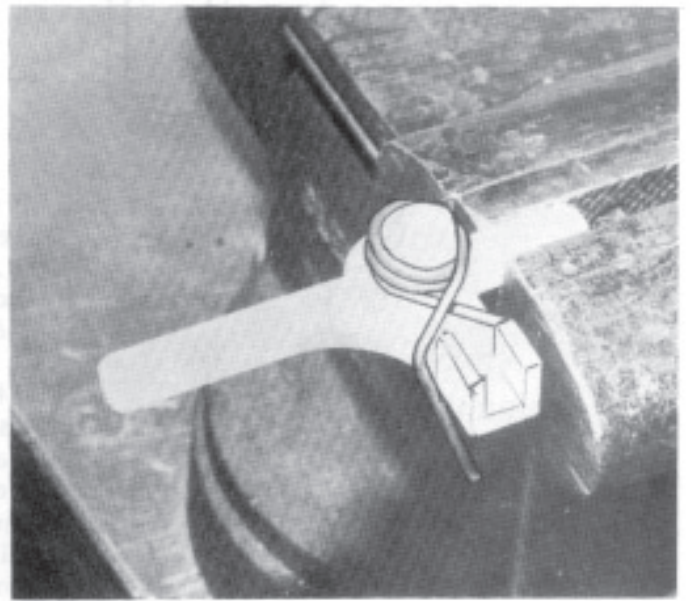

#4 When you have the spring crossed over, push the coil down. The spring will now stay in place. Remove the nut, washer & screw. Assemble the Servo Saver per STEP #2 on the other side.