

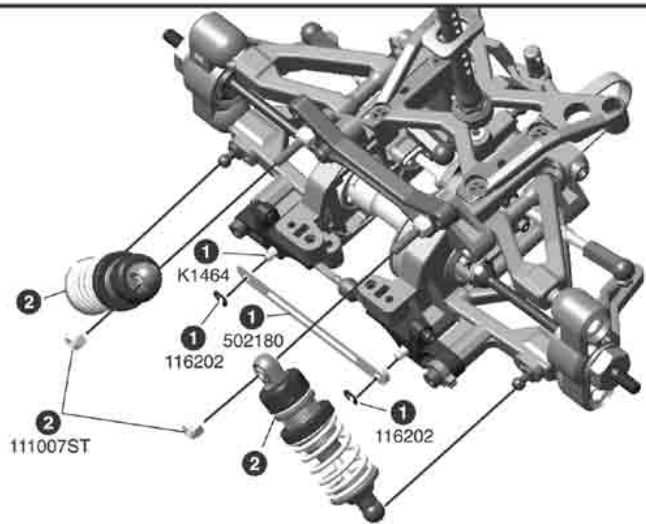





















STEP 7

Front Shock Assembly

- Slide #502180 front lower arm stiffener brace onto the end of the #K1464 front lower arm hinge pins & install 2pcs #116202 E-clip 2.5 on the hinge pins.
- Push the Shock cap over the cap screw & add #111007ST locknut. Snap the shock ball cup into place where shown.



BAG G

						
1:1	1:1	1:1	1:1	1:1	1:1	1:1
502183, qty 2 2x12mm Cross RH TP screw	116310RCR, qty 2 3x10mm Cross RH TP screw	111007F, qty 3 3mm flat locknut	126308CR, qty 3 3x8mm Cross FH Screw	116310CR, qty 4 3x10mm Cross FH TP screw	502186, qty 2 Bumper Foam Post Washer	111120, qty 2 R6 R-clip
						
502187, qty 1 3mm Chassis	502184, qty 1 Front Lower Bumper	502185, qty 1 Front Upper Bumper	502188, qty 1 Bumper Foam	502183, qty 2 Front Body Post	502186, qty 2 Bumper Foam Post	502186, qty 4 Bumper Foam Post Pad
						
G4	G1	G1	G6	G3	G1	G3

STEP 1

Front Upper Bumper Assembly

- Attach 2pcs #502183 body posts to the #502185 front upper bumper with 2pcs #116310RCR 3x10mm cross RH TP screws.
- Slide #502183 pivoting body mounts over the body posts so the holes line up with the second hole from the bottom. Then, fasten with #502183 2x12mm cross RH TP screws.

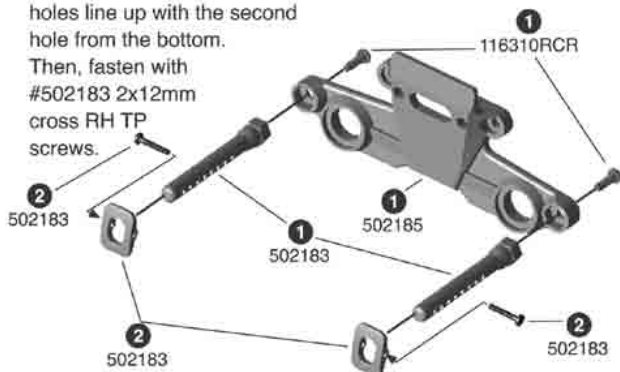

STEP 2

Front Lower Bumper Assembly

- Align 3pcs #111007F 3mm flat nuts with hexagonal slots on the #502184 front lower bumper. Attach the front lower bumper to the #502187 chassis with 3pcs #126308CR 3x8mm cross RH screws.
- foam bumper post pads into the front lower bumper, making sure the shoulder is facing down. Slide #502186 foam bumper posts through the pads.

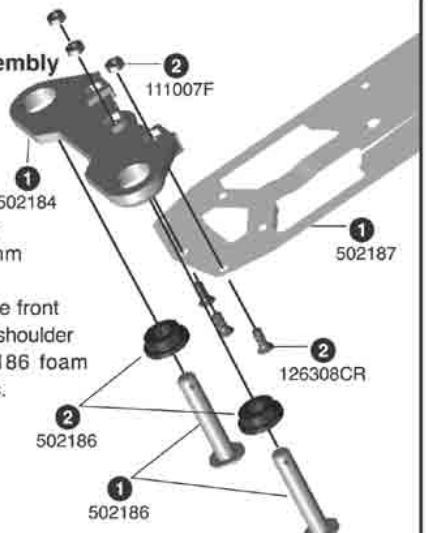

STEP 3

- 1 Attach the front suspension system assembly to the #502187 chassis with 4pcs #116310CR 3x10mm cross FH TP screws.
- 2 Place the #502188 foam bumper on the lower bumper assembly.

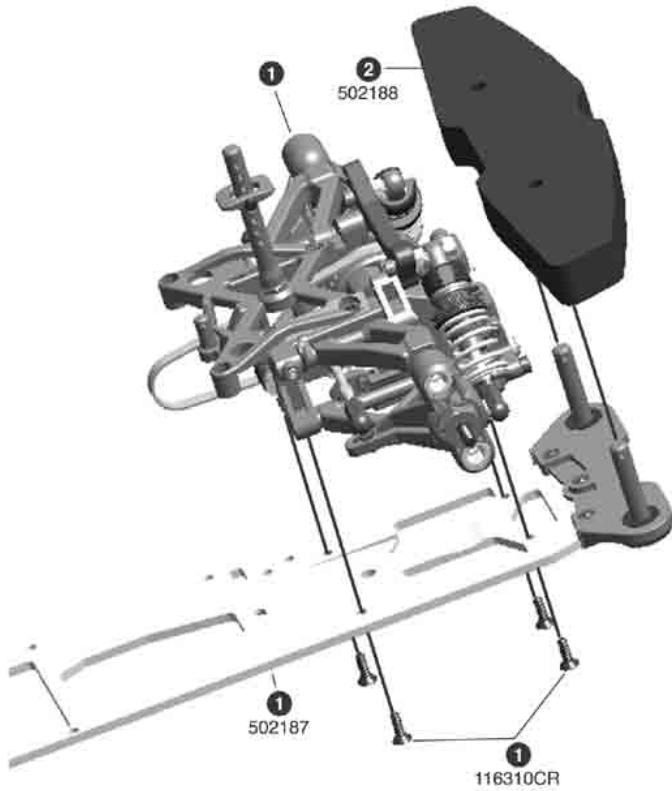

STEP 4

Front Upper Bumper Assembly

- 1 Attach the front upper bumper assembly to the foam bumper assembly with 2pcs #116310RCR 3x10mm cross RH TP screws.
- 2 Slide #502186 pads & washers through foam bumper posts & slide in #111120 R6 R-clips.

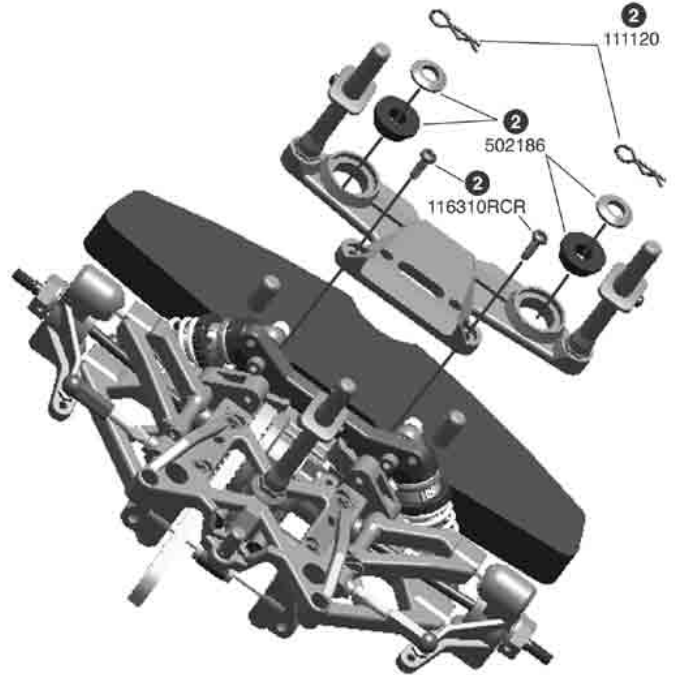

BAG H

1:1



116202, qty 4
E2.5 E-clip

H5

1:1



502191, qty 2
2x10mm Cross
RH TP Screw

H2

1:1



502191, qty 2
2x12mm Cross
RH TP Screw

H6

1:1



116312RCR, qty 2
3x12mm Cross RH
TP Screw

H8

1:1



502192, qty 2
Alum. 4x18mm
Adjustable Rod

H3

1:1



K1465, qty 2
Hardened Hinge Pin
(Rear Upper)

H9

1:1



502193, qty 1
Ball Cup
(for 4mm rod)

H4



502190, qty 1
Rear Shock Tower

H1



502193, qty 1
Rear Upper
Rod End

H9



502191, qty 2
Pivoting Body
Mount

H3



502191, qty 2
Extension
Body Post

H1



502191, qty 2
Rear Body Post

H1

STEP 1

Rear Body Post Assembly

- Place the #502191 rear body posts to the front side of the #502190 rear shock tower. Attach the posts with #116312RCR 3x12mm cross RH TP screws.
- Slide the #502191 pivoting body mounts over the body posts so the holes line up with the fourth hole from the bottom, then attach #502191 2x12mm cross RH TP screws to hold the body mount in place. You may need to readjust this depends on your body style.
- If the rear body post is not tall enough, please use #502191 extension body posts to extend the height. Slide the #502191 extension body post over the rear body post so its holes line up with the second hole from the top, then attach a #502191 2x10mm cross RH TP screw to hold the extension mount in place.
- Slide the #502191 pivoting body mounts over the extension body posts so the holes line up with the second hole from the top, then attach #502191 2x12mm cross RH TP screws to hold the body mount in place. You may need to readjust this depends on your body style.

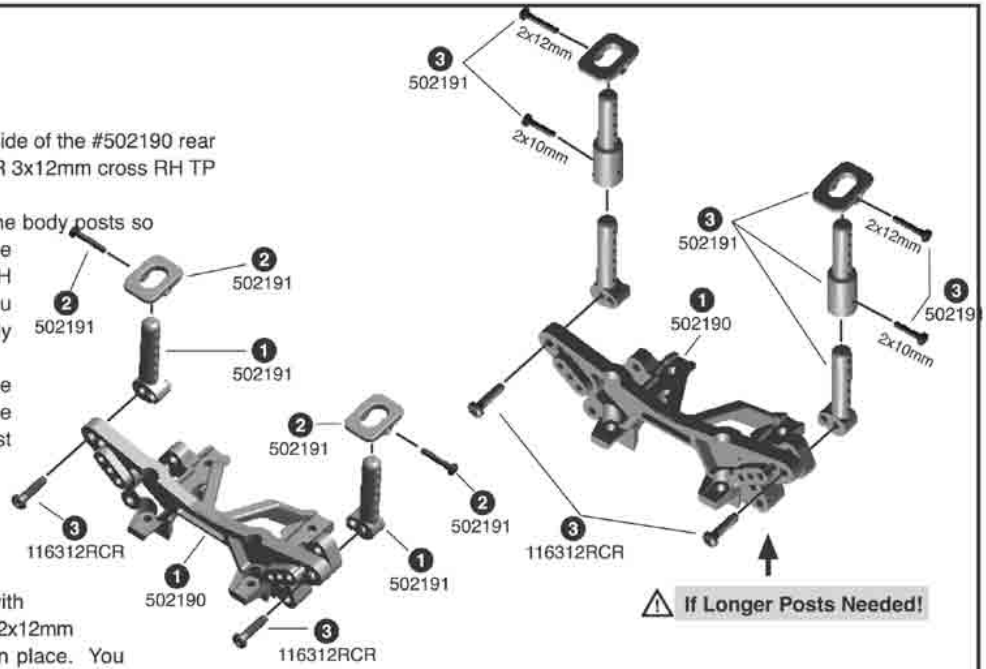

STEP 2

Rear Upper Link Assembly

- Twist the #502193 ball cup & rod end onto the #502192 alum. 4x18mm adjustable rod until you get the dimension shown. Assemble both rear upper arms.
- Line up the rear upper link assembly with the lower hole on the shock tower. Push #K1465 rear upper hinge pins into the tower & arm. Install #116202 E-clip 2.5 on both side of the hinge pins.

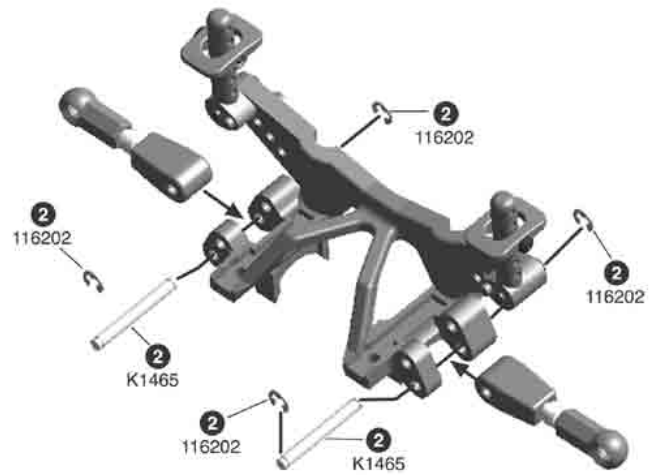
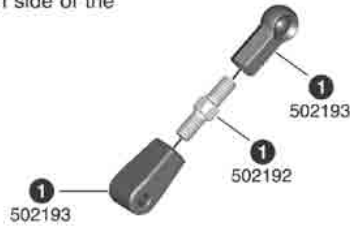
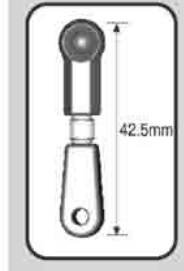

BAG I

	1:1 	1:1 	1:1 	1:1 	1:1 	1:1 	1:1 	1:1
502202, qty 1 19T Brake Pulley Mount 18	502202, qty 1 4x4mm Set Screw 18	502197, qty 1 Brake Cam Cylinder 12	116201, qty 2 2x11mm Pin 08	116310CR, qty 2 3x10mm Cross FH TP Screw 07	126314BU, qty 2 3x14mm Button Head Screw 14	126408S, qty 1 4x8mm Set Screw 02	150612, qty 1 6x12x4mm Bearing 06	116203, qty 1 E5 E-clip 19
502202, qty 1 19T Brake Pulley Gear 18	502203, qty 1 2 Speed Housing Dust Cover 11	502198, qty 2 Brake Pad 03	502198, qty 2 Brake Plate 03	502197, qty 1 Brake Cam 02	502201, qty 1 Brake Disc 17	502199, qty 1 Right Alum. Side Plate 15	502200, qty 1 2 Speed Shaft 05	502196, qty 1 Right Rear Bulkhead 07

STEP 1

Right Rear Bulkhead Assembly

- Lightly scuff the side of # 502198 brake pad you will be gluing the pad to. The elongated hole on the pad and plate must face down. Apply some contact cement to one side of the pad and one side on the plate. Attach them together.
- Slide #502197 brake cam into #502196 right rear bulkhead.
- Fit #502197 brake cam cylinder into the right rear bulkhead.
- Attach two brake plate assemblies to with two screws. You want to thread the screw in until there is a 2mm space between the 2 pads.

Use CA Or Contact Cement

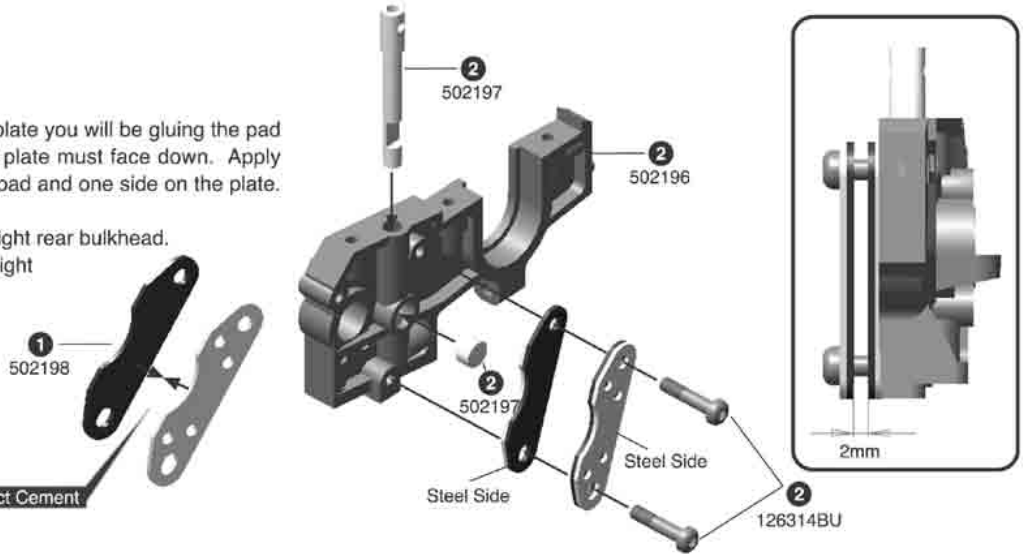

STEP 2

Right Alum. Side Plat Assembly

- Install a #126408S 4x8mm set screw into the #502196 right rear bulkhead. **PLEASE REFER TO FINAL ADJUSTMENTS - UP STOP SETTING.**
- Attach the #502199 right alum. side plate to the right rear bulkhead with two #116310CR 3x10mm cross FH TP screws.

