

# Contents

<b>Topic</b>		<b>Page</b>
Before using the M11		1-2
NiCd Batteries		3
Transmitter Features and Controls		4-5
Key Pad Menu Buttons		6
Function Pages	F1, F2, F3	7
Battery / Operation Timer	BATT	8
Dual Rate Steering	D-RATE	9
End Point Adjustment	EPA	10-11-12-13
Exponential	EXP	14-15
Adjustable Rate Control	ARC	16-17
Speed	SPEED	18-19
Anti-Lock Braking	ALB	20
Traction Control	TR-CTL	21-22
Model	MODEL	23-24
Sub Trim	SUB-T	25
Timer	TIMER	26-27-28-29-30
Timer / Servo Reversing	REV	30
Start Position	S-POS	31
Throttle Hold	TH-HLD	32
Brake Mix	BR-MIX	33-34
C-Mix	C-MIX	35-36-37
Servo	SERVO	38
Set-up	SET-UP	39-40
Audio Signal Sound	SIGNL	41-42
Switch / Trim Assignment	E-ASGN	43-44-45
User Name	USER	46
Direct Servo Controller	DSC	47
Receiver Connections and Installation		48
Troubleshooting		49

# Before Using the M11

## Driving Position Adjustments

Every effort has been made to provide optimum transmitter weight and balance on your M11. The wheel and trigger are placed on the same axis, permitting you to focus on steering and throttle control. The driving position and steering/throttle tension are adjustable to maximize driving precision.

### Steering Wheel Tension

The steering spring tension can be adjusted using a 1.5 mm hex wrench as shown in the photo. Steering spring tension will increase as you tighten the hex bolt. Note: The spring tension is factory set at the lowest (softest) position.



### Driving Position

1. Remove the 4mm hex socket head cap screws on each side of the transmitter using a 3mm hex wrench.
2. Detach the grip downward from the upper transmitter unit. Be careful to avoid damaging the lead wires that are connected on both units.
3. There are four (4) Phillips screws holding each side of the grip bracket. Remove the screws and reset the bracket screw hole at the lower screw hole. This sets the bracket to the higher height position. Note: The grip bracket is factory set to the lower height position.
4. After resetting the driving position, retighten the grip bracket screws. Attach the upper part of the transmitter unit into position with two (2) 4mm hex socket head cap screws and a 3mm hex wrench.

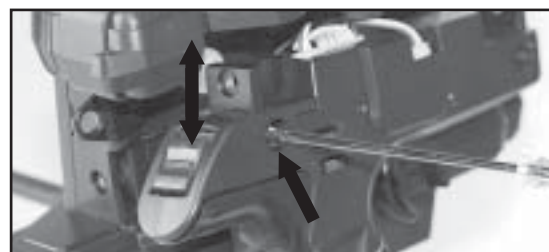

### Throttle Trigger Tension

1. Remove the 4mm hex socket head cap screws on each side of the transmitter using a 3mm hex wrench.
2. Detach the grip downward from the upper transmitter unit. Be careful to avoid damaging the lead wires that are connected on both units.
3. Adjust the throttle trigger spring tension using a 1.5 mm hex driver. Location of the 1.5mm hex bolt is shown in the photo. Throttle trigger spring tension increases as you tighten the hex bolt. Note: The spring tension is factory set to the lowest (softest) position.
4. After resetting the throttle trigger spring tension, align the upper transmitter unit into place. Tighten using the 3mm hex wrench and two (2) 4mm hex socket head cap screws per side.

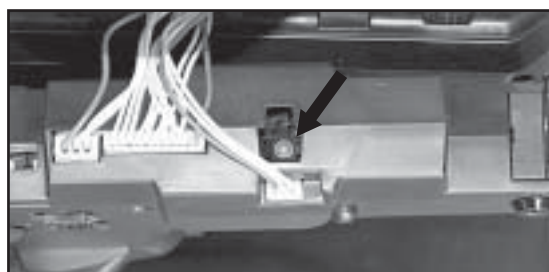

# Before Using the M11 (Cont)

## Trim Position

Trim position may be adjusted (5 positions) by rotating the trimmer unit.

1. Remove the 4mm hex socket head cap screws on each side of the transmitter by using a 3mm hex wrench.
2. Detach the grip downward from the upper transmitter unit. Be careful to avoid damaging the lead wires that are connected on both units.
3. Remove the three hex socket head cap screws (M2.6) from the backside of the trimmer unit (i.e. behind the steering wheel as shown on the photo.)
4. Rotate the trimmer unit to the desired position. Trim position may be selected from five (5) positions. Set the trimmer unit at optimum trim position. After selecting the position, retighten the hex socket head cap screws (M2.6).
5. After resetting the trimmer position, attach the upper transmitter unit back into place. Tighten using a 3mm hex wrench and two (2) 4mm hex socket head cap screws per side.

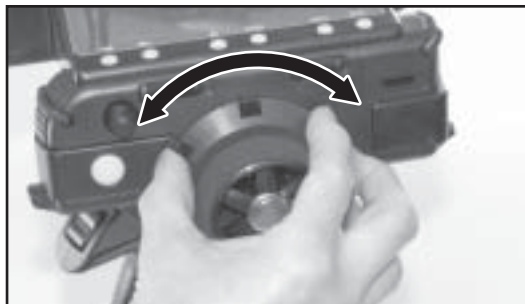

## Switching Right Driving position to Left Driving Position (Dominant hand)

In order to change to a left handed driving position, rotate the grip as follows:

1. Remove the 4mm hex socket head cap screws on each side of the transmitter using a 3mm hex wrench.
2. Detach the grip downward from the upper transmitter unit. Be careful to avoid damaging the lead wires that are connected on both units.
3. Set the Left/Right selector switch to L. located above TRM 4 and TRM 5.
4. Rotate the grip by 180 degrees.
5. After rotating the grip, align the upper transmitter unit into place. Tighten using a 3mm hex wrench and two (2) 4mm hex socket head cap screws per side.



# NiCd Batteries

## Safety Precautions When Charging A NiCd Battery.

(Optional part)

### CAUTION!

- \* Please read the charging procedures listed below to ensure safe and correct use of your NiCd battery.
- \* The battery is not charged when purchased. It is necessary to charge the battery before operation.
- \* Before charging NiCd batteries, double check power switches are in the off position on the transmitter and/or receiver.

## Charging the Transmitter/Receiver NiCd Batteries.

1. Connect the supplied charger to AC power outlet.
2. Charging the transmitter NiCd battery: Connect the round charger jack to the transmitter-charging outlet.
3. Charging the receiver NiCd battery: Connect the square plug from the charger to the connector on the switch harness, or NiCd battery, depending on your setup.

- \* Make sure that the charging indicator LED light is on.

Charging a battery for the specified period may not result in a full charge if you have a new battery or have not used the battery for an extended period of time. In this case, you can activate the battery for use by running it through two or three charge cycles.

**NOTE:** The receiver plug can not be used to charge the transmitter NiCd battery pack when the battery pack is out side the transmitter.

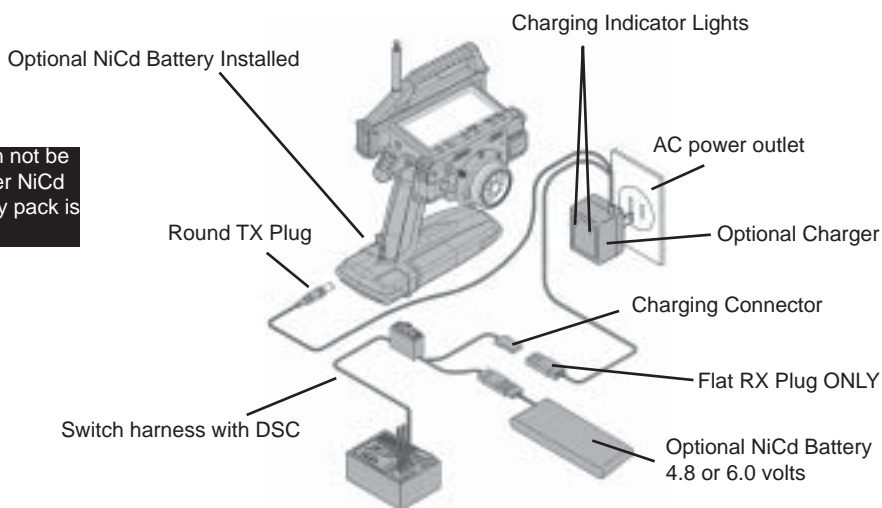

**WARNING:** To prevent serious personal injury and/or damage to property, you must observe the following precautions when handling NiCd batteries.

Incorrect use can result in electrolyte spills, overheating, and bursting.

- \* Use only SANWA optional charger for charging your NiCd batteries and never charge for more than the specified amount of time.
- \* Overcharging damages a battery and can result in overheating, bursting, and electrolyte spillage. This may cause personal injury and/or to property (i.e. burns, fire, or damage to the eyes.)
- \* When connecting the charger connector to the receiver NiCd battery or switch harness, be careful to avoid reversing the polarity or shorting the connector.
- \* Do not dispose of the battery in any fire or allow it to overheat.
- \* Do not short-circuit the positive terminal or the negative terminals with wire or any other object.
- \* Do not remove the outer tube. This is for protection and prevents scratches or other damage.
- \* Do not throw the battery or abuse it in any manner.

# Transmitter Features and Controls

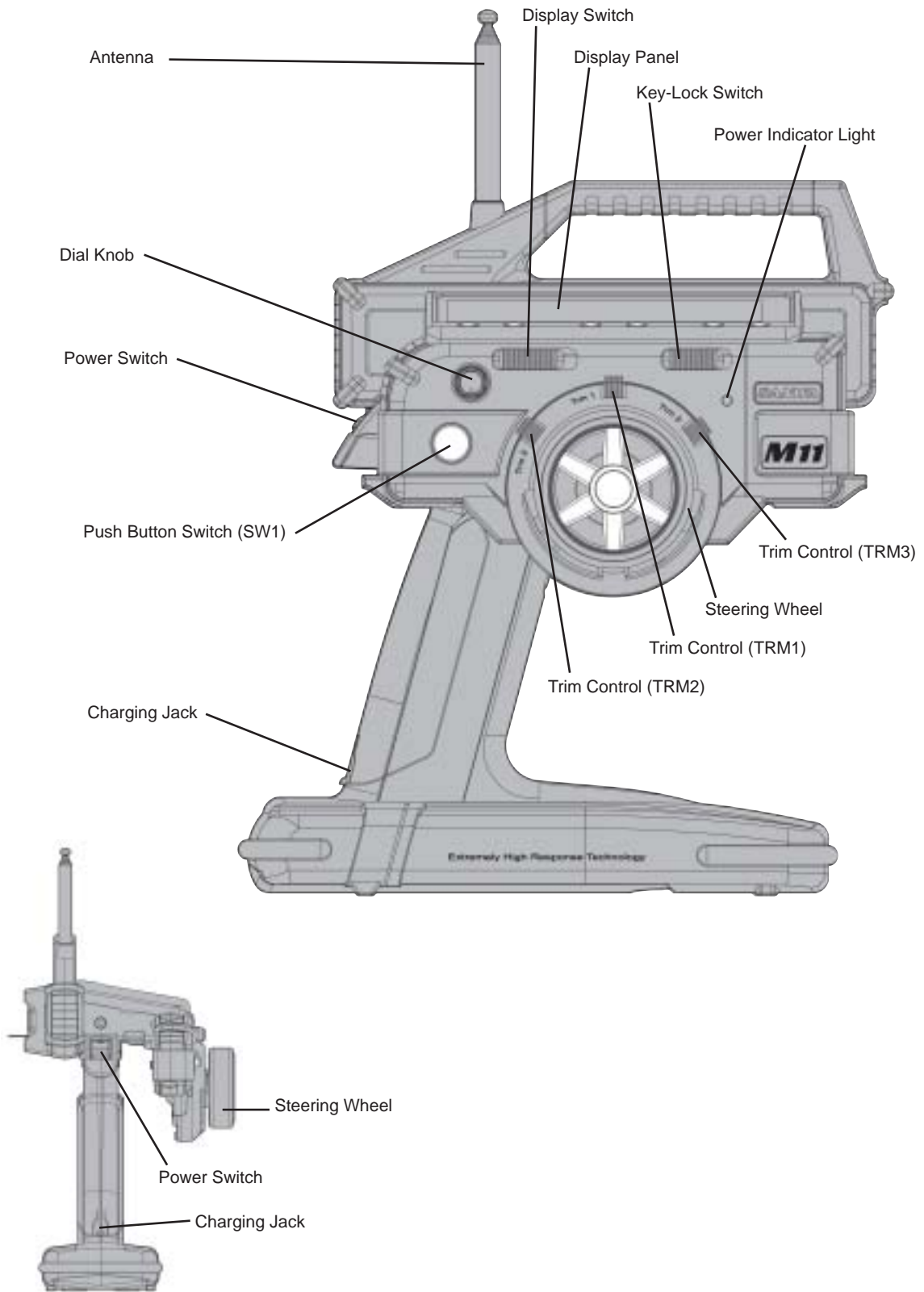

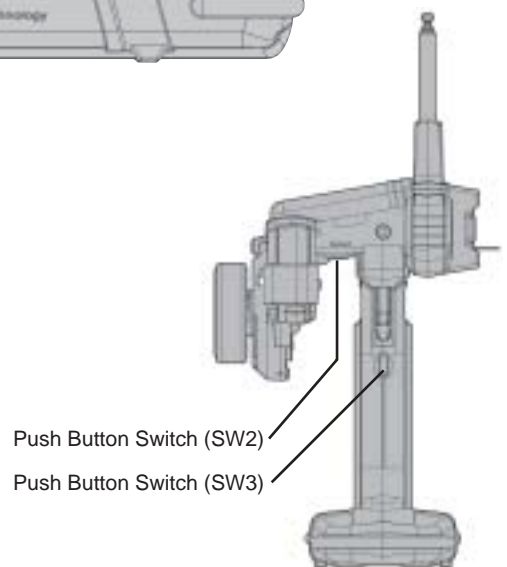
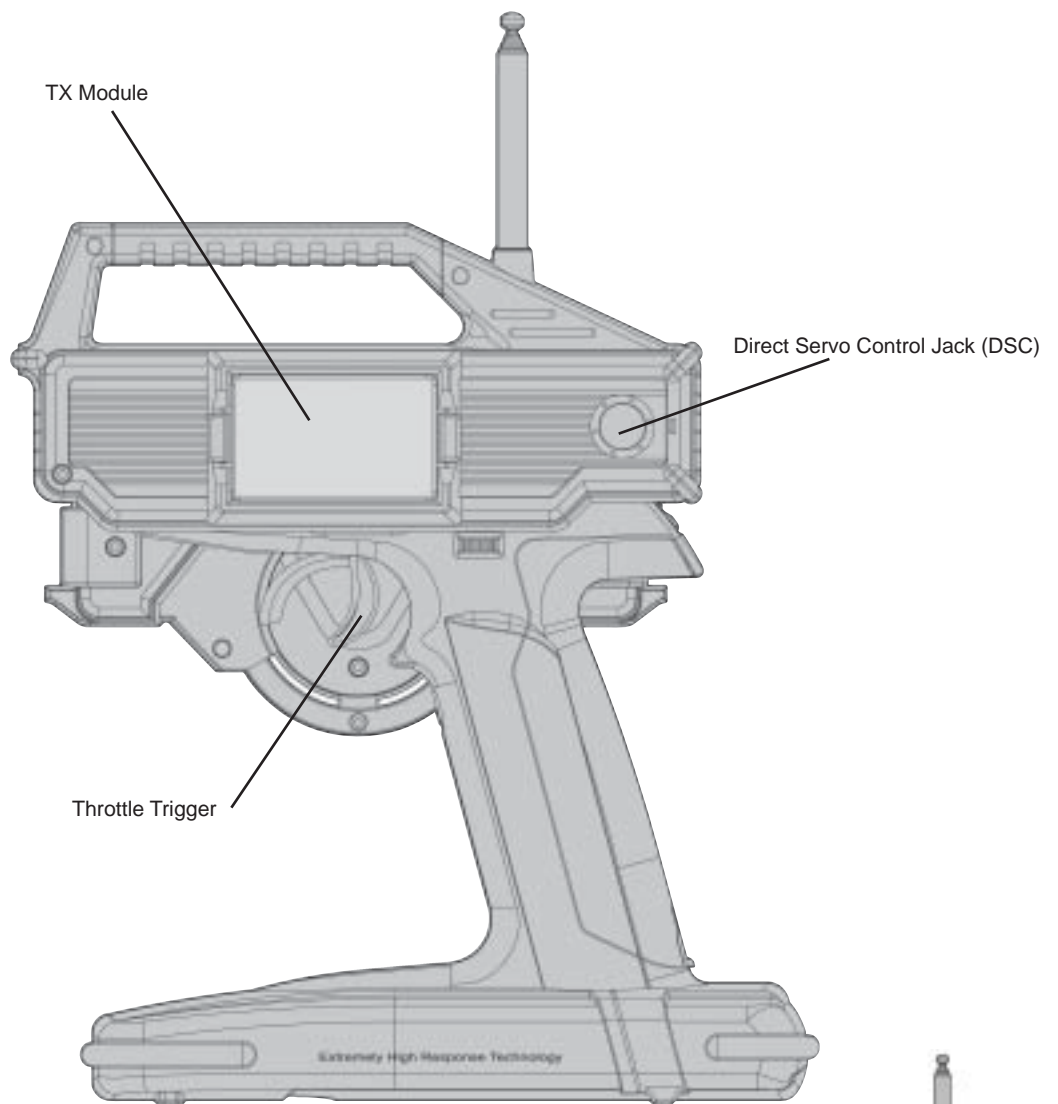









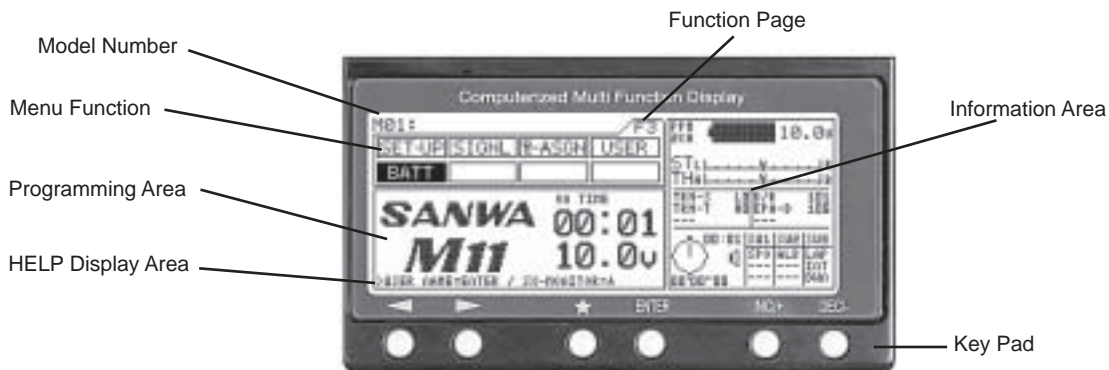

# Key Pad Menu Buttons

## Using the Key Pad Menu Buttons

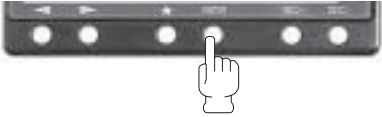
The M11 has 6 keys for menu operations. You will find the use of the 6 keys summarized below.



Key	Name	Function
	Function select Key (Left)	Moves the Menu Function cursor left to the previous (backwards) menu function.
	Function select Key (Right)	Moves the Menu Function cursor right to the next (forward) menu function.
	Function Page select Key sequence	Pressing down on both keys will scroll through function pages in order. F1, F2 and F3. The menu function cursor will highlight the first function on that page.
	★ Scroll Key	Will move the menu key backwards in the programming area. Also used in the HELP display area.
	Enter Key	Will move the menu key forward in the programming area. Also used in the HELP display area.
	INC+ Key (Increase)	Increases number values in programming area. Scrolls up selection list.
	DEC- Key (Decrease)	Decreases number values in programming area. Scrolls down selection list.
	INC+ and DEC- (Reset)	Resets selection to factory default setting.

# Function Pages

## Menu Function Pages / Information Area

The functions of the M11 span three pages, F1 to F3, and can be selected directly using just the < function > keys. The first function on successive pages can be easily displayed in the sequence F1 > F2 > F3 > F1 . . . by pressing the < function > keys at the same time.

Function Menu Page 1

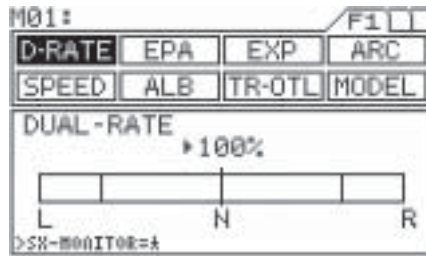

Function Menu Page 2



Function Menu Page 3

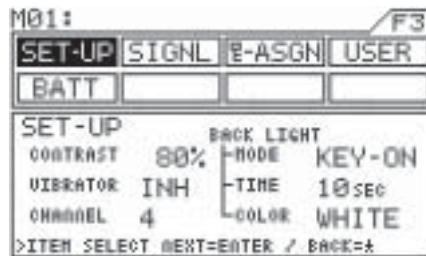

A constant display area is provided on the right side of the screen. This makes it possible to determine, at a glance, the current setting status of various functions from any menu screen. Further, you can display the servo monitor screen by pressing the ★key.

Optional information screen can be changed using the ★key. Note: can only be changed when the help screen shows SX-MONITOR



The transmitter battery voltage can be seen in two separate windows and measures 0.1 of a volt.

- 1. BATT Menu
- 2. Information Menu



Battery voltage indicator

M11 Screen

A screenshot of the M11 screen. The top menu shows SET-UP, SIGNAL, E-ASGN, and USER. The BATT option is selected. The main display shows "SANWA" and "M11". The battery voltage is displayed as "10.0v".

NOTE: This area of the information screen is not programmable and will stay on all the time.

In the BATT menu, you can press the ENTER key to switch between the user and M11 screens.

Will start blinking if battery reaches 9.1 volts or below.

User Name Screen

A screenshot of the User Name Screen. The top menu shows SET-UP, SIGNAL, E-ASGN, and USER. The BATT option is selected. The main display shows "SANWA" and "Joe Driver". The battery voltage is displayed as "10.0v".

When the transmitter battery runs down to 9.1 volts, the transmitter will start beeping and vibrating if the vibration feature is on and will continue every 30 seconds. When this happens, promptly stop operation and charge or replace the transmitter batteries.

## Operating Timer

The operating timer is an up timer that records the time the transmitter has been on in hours and minutes. This timer can be reset to 00:00 by pressing both the (INC/+) (DEC/-) keys at the same time. Resetting the Operating timer after you have charged or replaced the transmitter battery will give you the amount of time the current battery has been in use.

A screenshot of the M11 screen. The top menu shows SET-UP, SIGNAL, E-ASGN, and USER. The BATT option is selected. The main display shows "SANWA" and "M11". The battery voltage is displayed as "10.0v".

Operation Timer in BATT screen

Operation Timer on all the time.



Dual Rate is used to change the amount of servo movement compared to the amount of movement with the steering wheel. Increasing the amount of dual rate will make the steering more sensitive or feel faster and decreasing the dual rate will make the steering more insensitive or feel slower.

When setting up a new car or truck, follow the directions below to properly setup your steering dual rate.

1. Set the digital steering trim to "0" by using (Trm 1). You can see when the trim reaches center by viewing one or both screens.

Steering trim factory default location: (Trm 1)

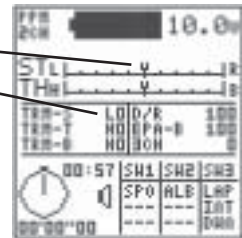
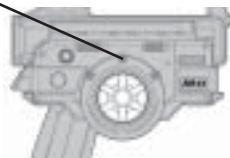

2. Press the function select key to move the cursor to (D-RATE). As you move the steering wheel from side to side, you can set the bar graph move to the dual rate limit lines. Default setting is 100%.

Adjust the dual rate by pressing the INC+ or DEC- keys to increase or decrease dual rate amount. At this time, set the dual rate to 125%. This will increase the servo movement by 25% in both left and right directions.

NOTE: Pressing both the INC and DEC keys together will set the dual rate to the default setting of 100%.

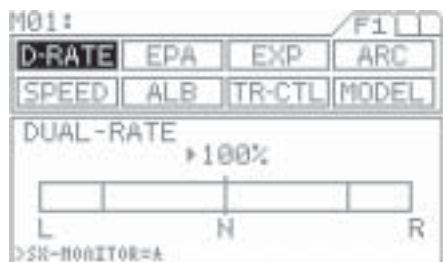

3. Attach the steering linkage to the servo arm as the car manufacturer recommends. Be sure to have all steering linkage, trim and the servo arm as close to center as possible. Doing so will cut out a lot of steering problems later.

Now move the steering wheel left and right to full. If your steering binds at both ends, this means you have too much movement coming from the servo. Use the dual rate to reduce or increase the amount of steering to reach the steering stops.

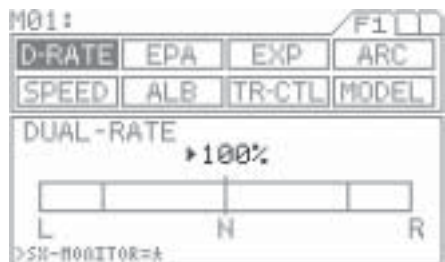

4. After the dual rate has been set, adjust the independent left and right end points using the EPA feature.

Trm 4 (top)

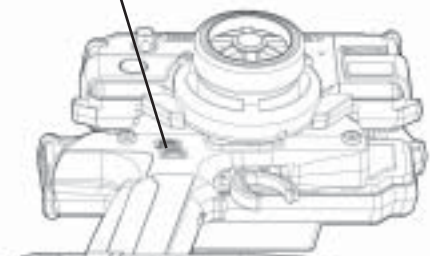



End point adjustment is used to adjust the proper amount of servo movement on the model's steering angle to steer left and right and/or adjust the carburetor throttle arm stroke, the high point of an ESC and brake stroke. While the M11 is set for 4 channels, this EPA function is also adjustable for the 3rd BRAKE or AUX Channel and the 4th channel brake.

**[ST]** Steering End Point Adjustment

A model's turning radius can differ from left to right because of variations in linkage, suspension balance, tire diameter or weight distribution of the vehicle. In such cases, the left and right servo steering angle is adjustable.

1. Before making the end point adjustment, you must set the servo to the neutral position. To find the center position, adjust the servo horn to approximately the center position, and then make fine adjustments using the sub-trim.
2. Next, press the function select key and move the cursor to [ST] in EPA.
3. To set the steering end point on the right side, turn the steering wheel fully clockwise and depress the Inc.+ or Dec.- key. To set the left steering end point, do the same with the steering wheel turned fully counterclockwise.

Setting range 0% to 150%  
Default setting 100%

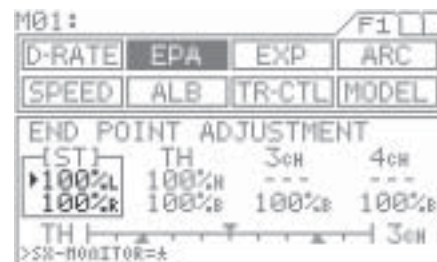
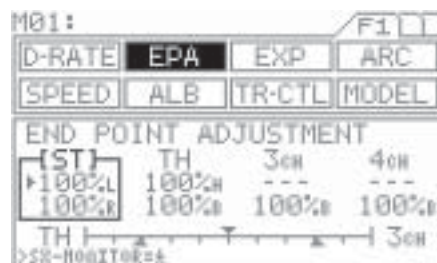

**IMPORTANT**

Note: Setting the steering dual rate and steering end points excessively high may cause a dead point on the servo, resulting in improper operation.

# End Point Adjustment (Cont)

## [TH] Throttle End Point Adjustment

Throttle end point adjustment is used to adjust the carburetor stroke, high point of an ESC, or the brake stroke.

1. Press the function select key and move the cursor to [TH] in EPA.
2. To adjust the high end of throttle movement on a gas powered car, pull the throttle trigger all the way to the high side and adjust by pressing the Inc.+ or Dec.- key.  
 To adjust the brake side, push the throttle trigger all the way to the brake side and adjust by pressing the Inc.+ or Dec.- key.  
 With an ESC, the high side and brake side are both ordinarily set to 100% and then the high point and brake point are set on the ESC.  
 (Setting procedures may vary depending on the type of ESC.)

Setting range 0% to 140%  
 Brake side 0% to 160%  
 Standard setting 100%

3. Test run your vehicle to set the brake adjustment by using TRM5 switch on the grip. You can vary the setting at EPA-B by adjusting with TRM5. While the M11 is set for 4 channels, setting value may vary at the same time.

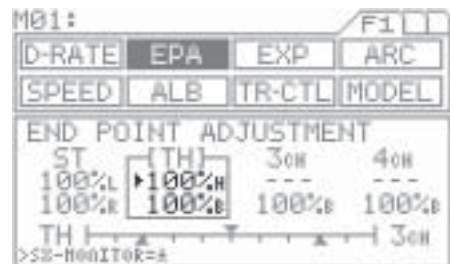
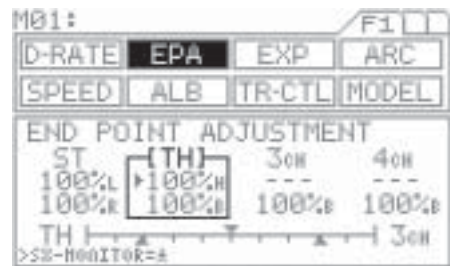

Trm 5 (bottom)

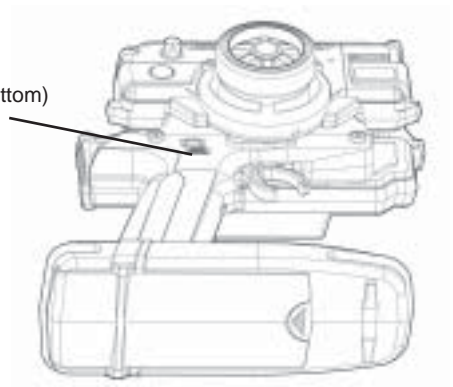

**NOTE**  
 With gas-powered model linkage, if the linkage stroke is set too wide, the servo may lock up. This results in fatal damage and may cause the vehicle to runaway.

**TIP**  
 Brake adjustment TRM5 switch can be assignable with other trim switches.

## [3ch] AUX End Point Adjustment ( with 3ch - BRAKE INH )

NOTE: In order to set any functions for AUX 3 and AUX 4, you must first set the channel setting from 2 to 4 channel. To change from 2 to 4 channel, go to the F3 page on the transmitter, move the function menu cursor to SET-Up and change the channel number in the programming area on the transmitter screen.

The AUX channel can be used for functions such as needle control or for other uses. The end point adjustment allows fine adjustments of the maximum servo travel. Further, the high end point and low end point can be set independently, which provides great flexibility of adjustment.

1. Be sure that channel 4 is selected in the set-up menu and that 3CH-BRAKE is set to INH in the BR-MIX menu. It is essential to set the M11 as "4channel" in order to use these functions.
2. Press the function select key and move the cursor to [3ch] in EPA.
3. To select the low side AUX setting, turn the dial counterclockwise and depress the Inc.+ or Dec.- key. To select the high side setting, do the same after turning the dial clockwise.

Setting range 0% to 150%  
Standard setting 100%

### TIP

The standard setting of the AUX channel is on the DIAL. \* This dial can be assignable with other trim switches such as TRM 1 to TRM5.

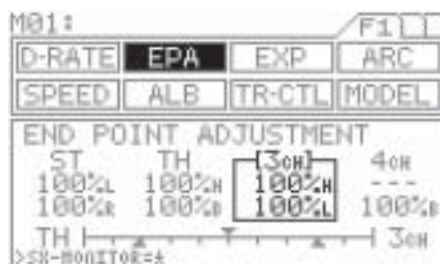

## [3ch] 3CH-BRAKE End Point Adjustment ( with 3ch - BRAKE ACT )

When using 3rd channel as the additional BRAKE channel, the end point adjustment can be separately set from the other BRAKE channel.

1. Make sure that channel 4 is selected in the set-up menu and that 3CH-BRAKE is set to ACT in the BR-MIX menu. It is essential to set this function in order to activate this set up menu.
2. Press the function select key and move the cursor to [3ch] in EPA.
3. Push the throttle trigger all the way to the brake side and then adjust by pressing the Inc.+ or Dec.- key.

Setting range 0% to 160%  
Standard setting 100%

4. If it is necessary to change the EPA brake adjustment during the operation of the vehicle, use trimmer TRM5 on the grip.

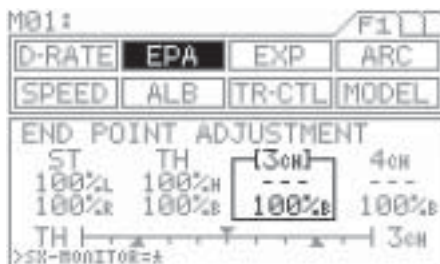

### IMPORTANT

\* Since this channel is exclusively for braking purposes, setting EPA covers only the BRAKE side.

# End Point Adjustment (Cont)

## [4ch] 4CH - BRAKE End Point Adjustment

The 4th channel is exclusively for braking purposes. When using the 4th channel as the additional BRAKE channel, end point adjustment can be separately set from the other BRAKE channel (3ch).

1. Be sure that channel 4 is selected in the set-up menu. It is essential to set this function in order to activate this set up menu.

2. Press the function select key and move the cursor to [4ch] in EPA.

Push the throttle trigger all the way to the brake side and then adjust by pressing the Inc.+ or Dec.- key.

Setting range 0% to 160%  
Standard setting 100%

3. If it is necessary to change the EPA brake adjustment, during the operation of the vehicle, use trimmer TRM5 on the grip.

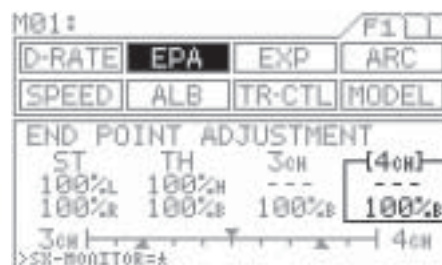

### IMPORTANT

Since this channel is exclusively for braking purposes, setting EPA covers only the BRAKE side.

### TIP

#### Balance bar graph

The bar graph appearing at the bottom of the screen is useful when setting the brake on more than two channels.

The graph indicates the center position of two EPA values. Use it as a guide for finding a good brake balance. The lower triangles in the graph indicate the respective EPA values.

When 3CH-BRAKE is set to ACT, the ENTER key switches the balance display between TH-3CH and 3CH-4CH. When 3CH-BRAKE is set to INH, the bar graph shows only the TH-4CH balance.

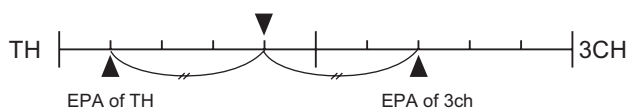



This function varies the amount of servo action with respect to manipulation of the steering wheel or throttle trigger based from the neutral position. Increasing the numeric value makes action quicker, while reducing it makes action slower.

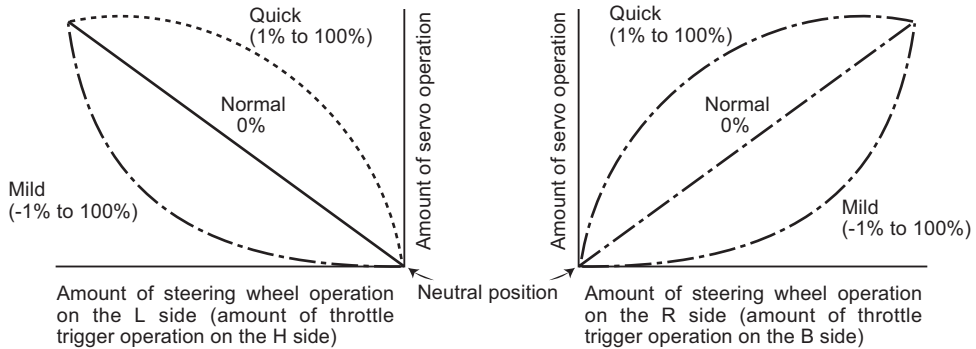

**[ST]** Steering Exponential

Three settings, Mild, Linear and Quick, allow you to set the most effective steering response for your model vehicle. Generally, if your model vehicle over-steers, reduce the numeric value. If it under-steers, increase the numeric value.

1. Press the function select key and move the cursor to [ST] in EXP.
2. Set the EXP quantity by pressing the Inc.+ or Dec.- key.

Setting range -100% to 100%  
Standard setting 0

TWEAK setting

3. Use the TWEAK setting when you want to fine-tune the left-right steering balance.  
First, move the cursor to below TWEAK with the ENTER key.  
To adjust the left side steering, turn the steering wheel to the left and set the cursor direction to <. To adjust the right side steering, turn the steering wheel to the right and set the cursor direction to >.  
Set the TWEAK quantity by pressing the Inc.+ or Dec.- key.

Setting range -20 to 20  
Standard setting 0

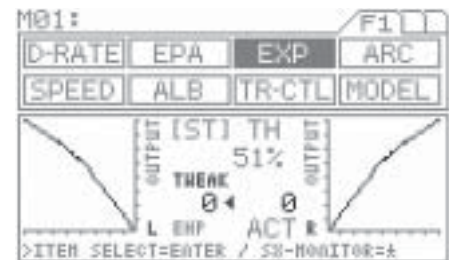
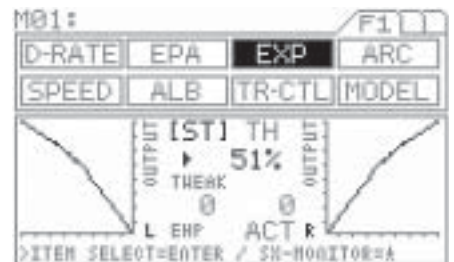

# Exponential (Cont)

## 4. INH/ACT setting for EXP

In order to activate the EXP function, select ACT; to deactivate, select INH. Using the ENTER key, move the cursor to the right side of EXP. Select INH or ACT by pressing the Inc.+ or Dec.- key.

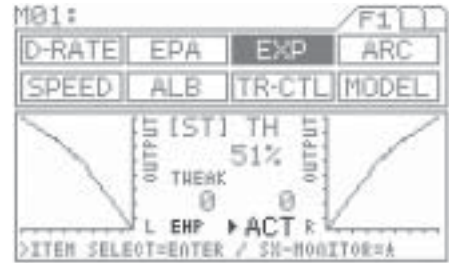

## [TH]

## Throttle Exponential

Throttle exponential can be adjusted from Mild, Linear and Quick. Generally, reduce the numeric value on a slippery track or with models that have powerful response. Increase the numeric value on a high-grip track or with power units that have lower torque. The high side and brake side can be set independently.

1. Press the function select key and move the cursor to [TH] in EXP.
2. Make sure that the cursor appears to the right of H, and then set the EXP amount for the high side of TH by pressing the Inc.+ or Dec.- key.

Setting range -100% to 100%  
Standard setting 0

3. Move the cursor to the right of B using the ENTER key, and then set the EXP amount for the brake side of TH by pressing the Inc.+ or Dec.- key.

Setting range -100% to 100%  
Standard setting 0

INH/ACT setting for EXP

4. Select ACT to activate the EXP function. Select INH to deactivate.

Using the ENTER key, move the cursor to the right side of EXP. Select INH or ACT by pressing the Inc.+ or Dec.- key.

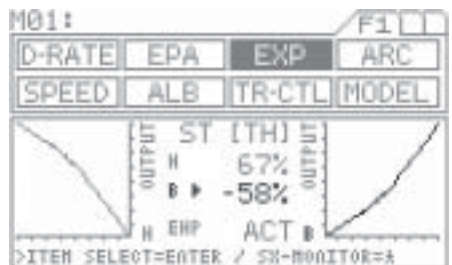
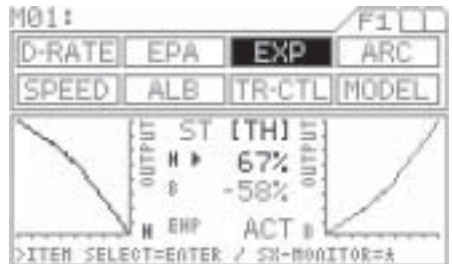

## IMPORTANT

About the INH/ACT setting for EXP

The INH/ACT setting of EXP in the menu can also be switched to any desired key switch by using the key assigning function. By using this function, switching the EXP "ON" or "OFF" can be selected during operation.

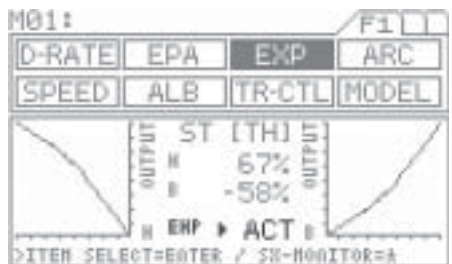

This function varies the amount of servo action with respect to manipulation of the steering wheel or throttle trigger. Increasing the rate setting makes action quicker, while reducing it makes action milder.

The changeability of the variable point on the ARC enables adjusting delicate steering and throttle during the operation.

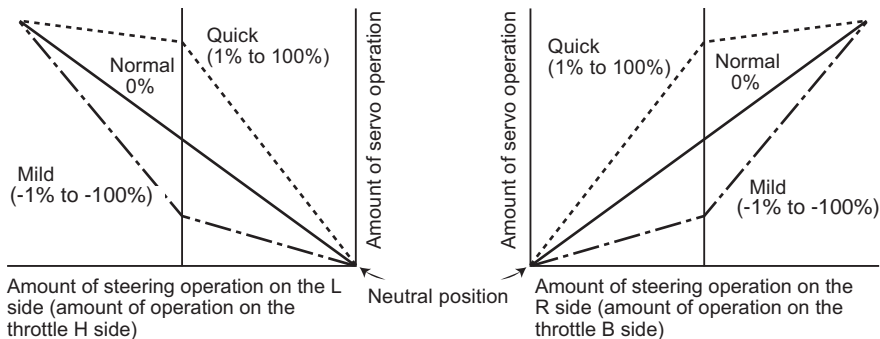

## [ST] Steering Adjustable Rate Control

Steering response can be variably adjusted from mild through linear to quick. In general, if the model vehicle tends to over-steer, reduce the numeric value, and if the vehicle tends to under-steer, increase the numeric value.

### RATE SETTING

1. Press the function select key and move the cursor to [ST] in ARC.
2. Be sure that the cursor points to the RATE, and then set the RATE for ARC by pressing the Inc.+ or Dec.- key.

Setting range -100% to 100% (Default setting 0)

### POINT setting

3. Move the cursor to POINT with the ENTER key, and then set the POINT value by pressing the Inc.+ or Dec.- key.

Setting range 5 to 95 (Default setting 50)

### INH/ACT setting for ARC

4. In order to activate the ARC function, select ACT, and to deactivate, select INH.

Using the ENTER key, move the cursor to the left side of ARC. Select INH or ACT by pressing the Inc.+ or Dec.- key.

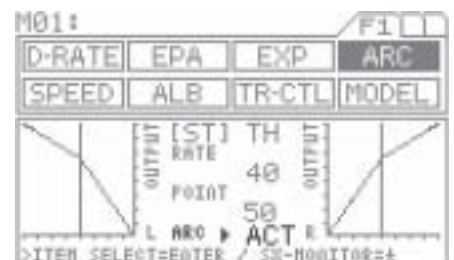
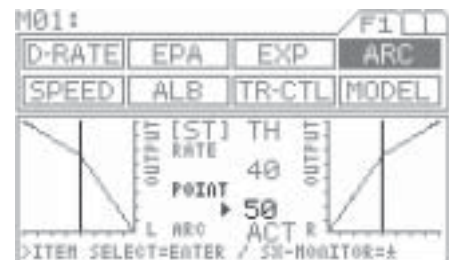
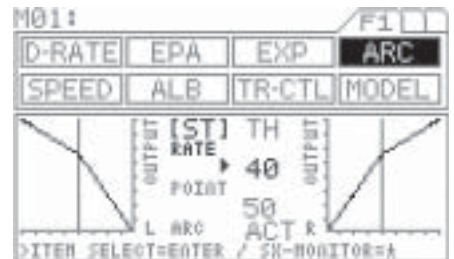

# Adjustable Rate Control (Cont)

[TH]

## Throttle Adjustable Rate Control

Throttle characteristic can be variably adjusted from mild through linear to quick. In general, reduce the numeric value on a slippery track or with models that have powerful response, and increase it on a high-grip track or with power units that have lower torque. The high side and brake side can be set independently.

1. Press the function select key and move the cursor to [TH] in ARC.

### RATE SETTING

2. Be sure that the cursor appears below RATE.  
To adjust the high side throttle setting, pull the throttle trigger all the way to change the cursor direction to the throttle rate.

To adjust the brake side throttle setting, push the throttle trigger all the way to the brake side, and watch the cursor direction change to the brake side.

Set the RATE by pressing the Inc.+ or Dec.- key.

Setting range -100 to 100 (Default setting 0)

### POINT SETTING

3. Move the cursor to below POINT with the ENTER key.  
To adjust the high side throttle setting, pull the throttle trigger all the way to the high side, this will change the cursor to the throttle side.

To adjust the brake side throttle setting, push the throttle trigger all the way to the brake side, and the cursor will change to the brake side.

Set the POINT value by pressing the Inc.+ or Dec.- key.

Setting range 5 to 95 (Default setting 50)

### INH/ACT setting for ARC

4. To activate the ARC function, select ACT, and to deactivate, select INH.

Using the ENTER key, move the cursor to the right side of ARC.  
Select INH or ACT by pressing the Inc.+ or Dec.- key.

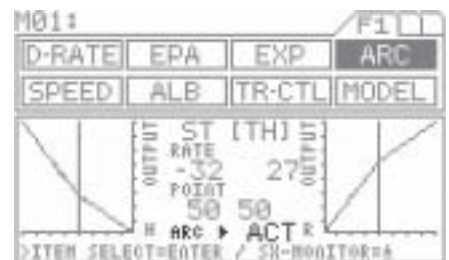
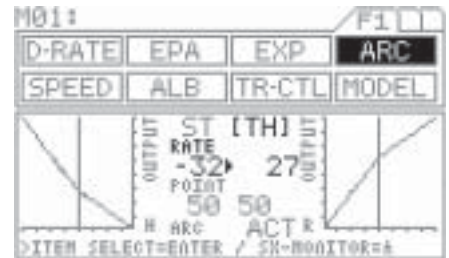

### IMPORTANT

About the INH/ACT setting for ARC

The INH/ACT setting for ARC in the menu can be switched to any desired key switch by using the key assign function. By using this function, Activation, of the ARC "ON" or "OFF" can be selected during operation.

This function slows down the steering servo speed during steering. Speed can be set separately for steering movement from neutral to a certain point and return directions.



Note: Actual steering operation is slower than the actual speed of the servo.

## [ST] Steering Servo Speed

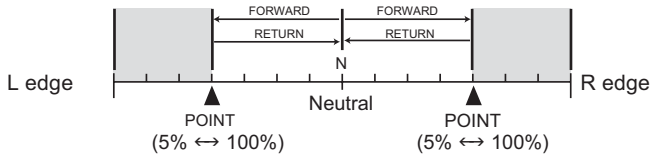

The SPEED setting does not effect steering when the wheel position is located with in the shaded areas outside the point positions.

- Using the function select keys, move the cursor to [ST] in SPEED.

### FORWARD SETTING

- Make sure that the cursor appears to the right of FORWARD, and then set the FORWARD value by pressing the Inc.+ or Dec.- key.

Setting range 0 to 100 (Default setting 0)

### RETURN SETTING

- Move the cursor to RETURN with the ENTER key, and then set the RETURN value by pressing the Inc.+ or Dec.- key.

Setting range 0 to 100 (Default setting 0)

### POINT SETTING

- Move the cursor to the right of POINT with the ENTER key, and then set the POINT value by pressing the Inc.+ or Dec.- key.

Setting range 5% to 100% (Default setting 100%)

### INH/ACT SPEED

- To activate the SPEED function, select ACT, and to deactivate, select INH.

Using the ENTER key, move the cursor to the right of SPEED. Select INH or ACT by pressing the Inc.+ or Dec.- key.

### NOTE

When driving a model vehicle, proper steering is vital, and excessive steering is to be avoided at all times. The steering speed setting helps to limit excessive steering, which will enable you to achieve smoother cornering.

It is advisable to use both Steering Speed & Exponential functions together to achieve the best combination of steering operation.





# Speed (Cont)

## [TH] Throttle Servo Speed

This function slows down the throttle servo during throttle operation. This setting effects only the FORWARD side of the brake.

The SPEED setting does not effect throttle operation when the throttle trigger positioning is located within the shaded areas outside the POINT. (Only effective from neutral to the point it is set at.)

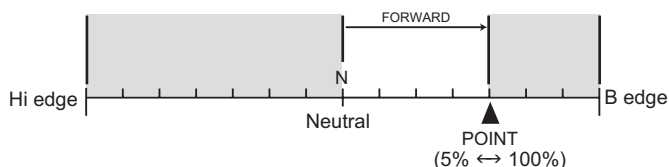

- Using the function select keys, move the cursor to [BR] in SPEED.

### FORWARD SETTING

- Make sure the cursor appears to the right of FORWARD, and then set the FORWARD value by pressing the Inc.+ or Dec.- key.

Setting range 0 to 100 (Default setting 0)

### POINT SETTING

- Move the cursor to the right of POINT with the ENTER key, and then set the POINT value by pressing the Inc.+ or Dec.- key.

Setting range 5% to 100% (Default setting 100%)

### INH/ACT SPEED

- To activate the SPEED function, select ACT, and to deactivate, select INH.

Using the ENTER key, move the cursor to the right of SPEED. Select INH or ACT by pressing the Inc.+ or Dec.- key.



**NOTE**  
It is advisable to use both Throttle Speed & Exponential functions together which enable you to achieve the best combination of steering operation for the model vehicle.

**IMPORTANT**  
About the INH/ACT setting for SPEED  
The INH/ACT setting for SPEED in the menu can also be changed to any desired switch by using the key assign function. By using this function, switching the SPEED "ON" or "OFF" can be selected during operation.



Anti-lock braking makes it possible to achieve stable braking even on a slippery track. With stable braking, the model vehicle may be able to trace an exact line as desired for corners.

This function also enables you to set different Braking characteristics depending on the model vehicle for on road racing or off road racing .

- Using the function select keys, move the cursor to ALB.



### POINT SETTING

- Be sure that the cursor appears to the right of POINT, and then set the POINT value by pressing the Inc.+ or Dec.- key.

POINT: The position where ALB activates.

Setting range 0% to 100% (Default setting 90%)

### STROKE SETTING

- Move the cursor to the right of STROKE with the ENTER key, and then set the STROKE value by pressing the Inc.+ or Dec.- key.

STROKE: The width of repeated operation.

Setting range 0 to 100 (Default setting 50)

### LAG SETTING

- Using the ENTER key, move the cursor to the right of LAG. Set the POINT value by pressing the Inc.+ or Dec.- key.

LAG: The time lag before ALB activates.

Setting range 0.0 to 2.0 (Default setting 0.5)

### SPEED SETTING

- Move the cursor to the right of SPEED with the ENTER key, and then set the SPEED value by pressing the Inc.+ or Dec.- key.

SPEED: The speed of repeated operation.

Setting range -1 to -30 (Default setting -2)

### NOTE

Set the hardest braking you can obtain from your model vehicle carefully setting the anti-lock braking at the point right before the tires get fully locked but not slip and lose traction on the track.

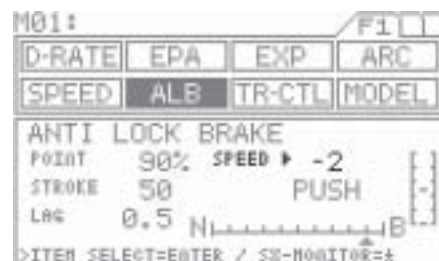
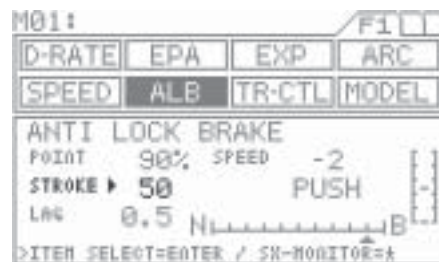

Traction control helps assure faster, smoother starts even when the trigger is applied abruptly by not having wheel spins.

Even with the model vehicle in forward motion, it contributes to the stability during acceleration, providing smoother running.



Ideal smoothness can be further refined by adjusting for intermittent locking in addition to normal servo speed delay adjustment. By making point settings and switch assignments (with the key assign function), traction control can be applied whenever necessary.

\* This function operates only when the throttle is moved from Neutral to the Hi direction.

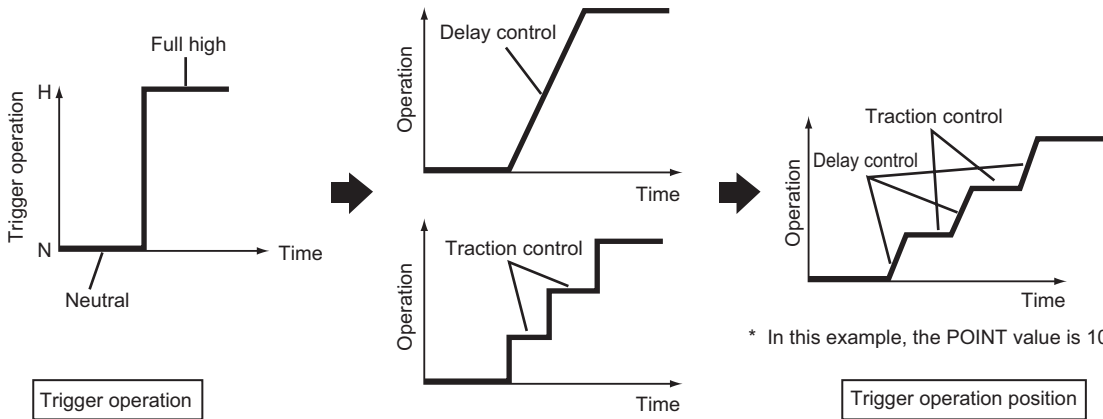

\* In this example, the POINT value is 100%.

- Using the function select keys, move the cursor to TR-CTL.

### TRACTION SETTING

- Be sure the cursor appears to the right of TRACTION, and then set the TRACTION value by pressing the Inc.+ or Dec.- key.

Setting range 1% to 100% (Default setting 1%) (off)  
Full throttle position

POINT position Bar graph (allows verification of output)

### DELAY SETTING

- Move the cursor to the right of DELAY with the ENTER key, and then set the DELAY value by pressing the Inc.+ or Dec.- key.

Setting range 0% to 100% (Default setting 0%)

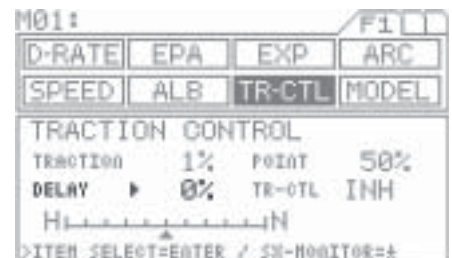
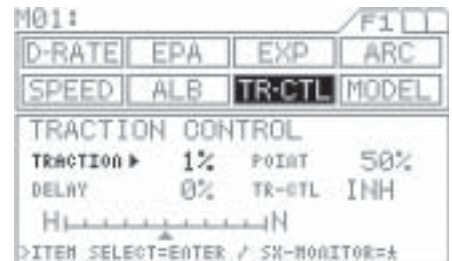

# Traction Control (Cont)

## POINT SETTING

4. Move the cursor to the right of POINT with the ENTER key, and then set the POINT value by pressing the Inc.+ or Dec.- key.

Setting range 5% to 100% (Default setting 50%)

Traction control applies only in the range from neutral to the set point.

## NOTE

The point referred to here is the operational output point, not the trigger operation point.

## INH/ACT setting for TR-CTL

5. To activate the traction control function, select ACT, and to deactivate, select INH.

Using the ENTER key, move the cursor to the right of TR-CTL.

Select INH or ACT by pressing the Inc.+ or Dec.- key.

## IMPORTANT

The INH/ACT setting of traction control in the menu can also be switched to any desired key by using the key assign function. By using this function, switching the TR-CTL "ON" or "OFF" can be selected during operation.

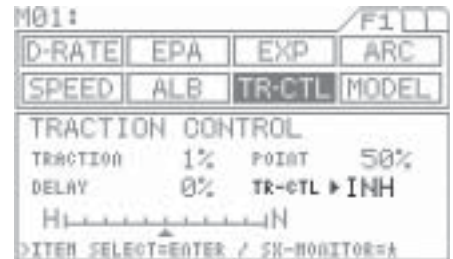
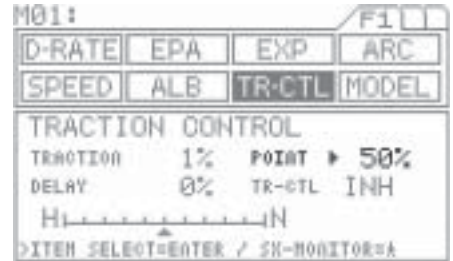

This menu enables you to make settings related to model select (SELECT), model name (NAME), and model copy/model clear (COPY/CLEAR) functions.

Data for up to 30 models, M01 to M30, can be stored in the M11's high capacity, built-in EEPROM memory.

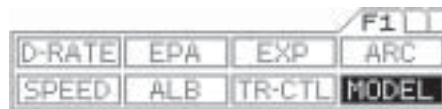

**[SELECT]** Model Select

Data can be easily stored for any model M01 to M30.

Since the previous model memories are stored automatically, there is no risk for accidental erasing.

- Using the function select keys, move the cursor to [NAME] in MODEL.
- Select the model to be recalled by pressing the Inc.+ or Dec.- key.



Setting range M01 to M30

**NOTE**

The model changes immediately upon selection.

Pages can be flipped through in sequence such as M01->M07->M13->M19->M25->M1...by simultaneously pressing the Inc.+ and Dec.- keys.

**! CAUTION**

Do not attempt to change the model when your model vehicle's receiver is turned on under actual operational conditions. The model vehicle may runaway or the servos may be damaged.

**[NAME]** Model Name

Model names can be registered consisting of up to 12 letters, numerals, or symbols.

- Using the function select keys, move the cursor to [NAME] in MODEL.
- Using the ★ key or the ENTER key, move the cursor (" ") to the point when you want to enter text.
- Select a character by pressing the Inc.+ or Dec.- key.
- Repeat steps 2) and 3) for each subsequent character.

Setting range A – Z, a – z, 0 – 9, symbols, space

**NOTE**

A group of characters can be flipped through in sequence A->a->0->!->space-> by simultaneously pressing the Inc.+ and Dec.- keys.

When entering a character in a position occupied by a space, a group can be selected from the preceding character by first pressing the Dec./- key. This is useful when entering several characters from the same group.



# Model (Cont)

## [COPY/CLEAR]

## Model Copy / Model Clear

This function enables you to copy data from the currently selected model to another, or to copy another model's data into the model currently selected. Data can be cleared (initialize) on the current model that is selected.

### COPY MODEL DATA

- Using the function select keys, move the cursor to [COPY/CLEAR] in MODEL.
- To copy data from the current selected (Master) model to another model (Slave), use the INC/+ or DEC/- keys to change the model numbers up or down to the model number you would like to copy the current model (Master) to.
- After you have selected the model number you wish to copy the current model (Master) to, press the ENTER key. The screen will now change and ask you:

YES=<INC> and NO=<DEC>

Press the INC/+ key to copy the current (Master) model to the new model (Slave) you have selected. Press the DEC/- key to return to the previous screen.

- To copy data from another model to the one you are currently using, use the ★ key to change the current model (Master) to (Slave). In turn the model you would like to copy from will now show (Master). The (Master) will always overwrite the (Slave).
- Select the model (Master) you want to copy from using the Inc.+ or Dec.- keys and then press the ENTER key.

A confirmation screen appears, allowing you to confirm that choice is correct. To proceed with copying, press Inc.+ , or to cancel press Dec.- key. During copying, the message EXECUTING! appears until copying is completed.

### CLEARING MODEL DATA

- Using the function select keys, move the cursor to [COPY/CLEAR] in MODEL.
- Using the ★ key, change the current model (Master) to (Slave).
- Press both INC/+ or DEC/- keys simultaneously to select the (- -:CLEAR) model.
- Now press the ENTER key to select. The screen will change and ask, YES=<INC> or NO=<DEC>. Select yes to clear the current model or no to return to the previous screen. This operation clears all data for models M01 to M30.

### NOTE:

CLEAR can be selected by simultaneously pressing Inc/+ and Dec/-.

While clearing is in progress, the message EXECUTING! appears until operation is completed.





This feature corrects trim neutral for steering and throttle, making it possible to use the main trim from the center position. When adjusting linkages, this sub-trim allows you to fix accurate center position. This can also be used for brake sub-trim when using 4 channels. In this case, channels 3 and 4 can be set independently.

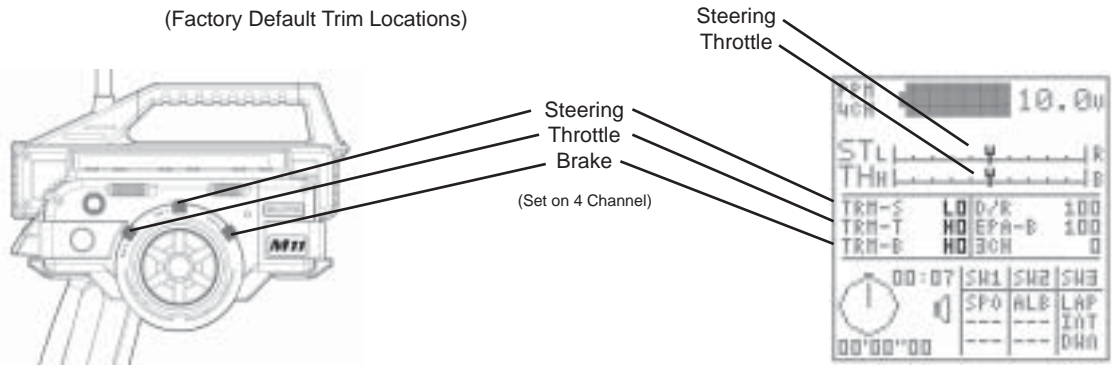

1. Before adjusting linkage, be sure to set the main trimmers to the center position (0).
2. Attach the servo arm (servo saver arm) to the servo unit in the position that is closest to neutral.
3. Using the function select keys, move the cursor to [ST] in SUB-T.
4. Adjust the sub-trim to center the servo arm.  
Setting range 100L to 100R (Default setting 0)
5. Adjust the other sub-trim settings in the same manner.

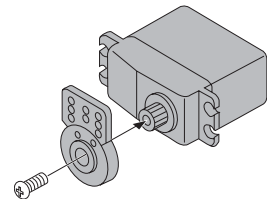

**! CAUTION**

Be sure that the servo is centered as close as possible before making this adjustment. If the sub-trim and main trim settings are both offset to one side, an operational dead spot (a spot where the servo does not operate) may result.



Three types of timers are provided for measuring lap, interval, and down (or up) times, and these three timers can be used simultaneously. A high degree of freedom and convenience is provided by the ability to use the key assign switch to perform simultaneous or independent operation. Separate tones can be assigned to each of the timers, making it easy to distinguish between them during simultaneous operation.



The audible signal provided by the tone is complemented by a vibrator, which can be set to operate either in concert with the tone, or simultaneously. The operational status of the timers can also be checked from other menus (in the constant display area).

**[LAP]** Lap Timer

This feature allows you to measure and record times for up to 99 laps.

It features a pre-alarm (PRE-ALM) that lets you set a pre-goal alarm time. Provides real-time display of the best lap (BEST), average lap (AVE), and total (TOTAL) lap times.



1. Using the function select keys, move the cursor to [TH] in TIMER.

2. Turning the lap timer (ON/OFF)  
Be sure that the cursor appears below LAP, and then press Inc.+ or Dec.- to set the timer ON or OFF.

Setting the goal time (GOAL)

3. Press the ENTER key to move the cursor to GOAL, and then set the goal time by pressing the Inc.+ or Dec.- key.



Setting range 00'10 to 60'00 In 00'10 increments (Default setting 60'00)

Setting the pre-alarm (PRE-ALM)

4. Press the ENTER key to move the cursor to PRE-ALM, and then set the pre-alarm by pressing the Inc.+ or Dec.- key.

The pre-alarm is an alarm that sounds a few seconds before the goal time.

Setting range OFF, 1s to 20s (Default setting 5s)

5. With the standard configuration, the lap timer switch is set to SW3. Pressing SW3 starts timer.



Lap time is measured each time you press SW3. Once you press the switch, it is deactivated for 3 seconds.

**IMPORTANT**

About the timer switch

The timer switch can be assigned to another switch using the key assign function. Set the switch to the position that is most suitable.

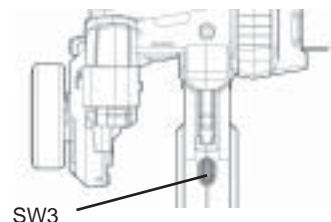

# Timer (Cont)

## ENDING MEASUREMENT

- End measurement can be set in two different ways.  
By pressing the switch after the goal time is reached.  
By pressing and holding the switch for 3 seconds.

## VERIFYING MEASUREMENT RESULTS

- Measurement results can be checked using the ★ key in the TIMER [LAP] menu while the timer is stopped. The display shows times for 9 laps at a time, Pages can be flipped by using the Inc.+ or Dec.- key.

Pressing Inc.+ and Dec.- simultaneously returns display to the first 9 laps.

## CONSTANT DISPLAY AREA

- The timer status appears in the constant display area, and can also be checked from other menus. The timers appear in the timer display area in the order FUNC1>FUNC2>FUNC3, as set with the key assign switch. In the example at right, LAP appears as assigned to FUNC1.

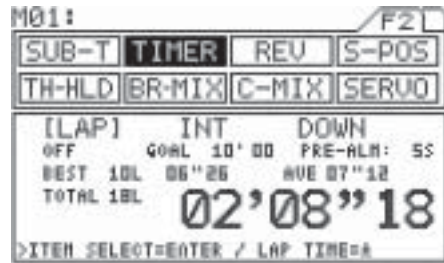

## ! CAUTION

When measurement is started, the previous LAP measurement is cleared. There is no function that is provided for clearing the lap time.

When measurement ends, the timer's ON/OFF status changes to OFF. To re-start the timer, turn it ON as described in step 2).

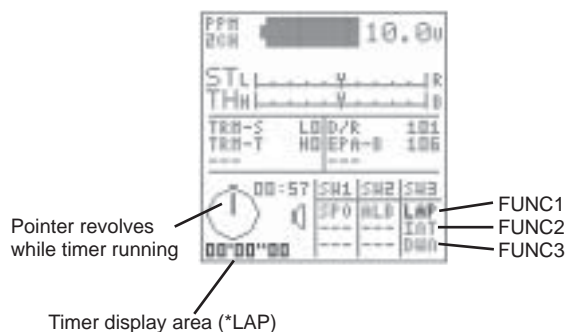

# Timer (Cont)

[INT]

Interval Timer

The interval timer notifies you when a set interval elapses while you are driving, giving you an idea how close you are to your target time. Interval timers are provided separately for minutes and seconds, and both can be used simultaneously. Timer tone can also be set separately for each two timers.

- Using the function select keys, move the cursor to [INT] in TIMER.

Turning the interval timer ON/OFF

- Make sure that the cursor appears below LAP, and then press Inc.+ or Dec.- to set the timer ON or OFF.

Setting the interval minute timer (MIN)

- Press the ENTER key to move the cursor to the right of MIN, and then set the timer by pressing the Inc.+ or Dec.- key.

The interval minute timer will not function when it is set as 00'.

Setting range 00' to 99' 01' increments (1-minute increments)

(Default setting 00')

Setting the interval second timer (SEC)

- Press the ENTER key to move the cursor to the right of SEC, and then set the timer by pressing the Inc.+ or Dec.- key.

Setting range 00" to 59" 01" increments (1-second increments)

(Default setting 00')

1/10-Seconds Setting

- Press the ENTER key to move the cursor to the left of 00", and then set the timer by pressing the Inc.+ or Dec.- key.

Setting range 00 to 90 Increments of 10 (1/10-second increments)

(Default setting 00)

The interval second timer will not function when it is set as 00"00.

- With the standard configuration, the lap timer switch is set to SW3. Pressing the SW3 switch starts measurement.

Each time you press SW3, the interval timer is reset and measurement re-starts from 0 minutes, 0 seconds.

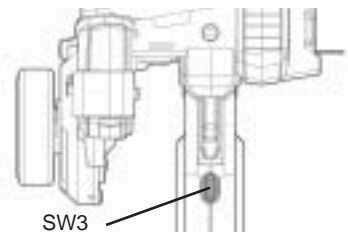

# Timer (Cont)

## ENDING MEASUREMENT

- End of measurement can be deactivated in two different ways.  
From the menu, by simultaneously pressing the Inc.+ and Dec.- key.  
By pressing and holding the switch for 3 seconds.



## IMPORTANT

When measurement ends, the timer's ON/OFF status changes to OFF. To re-start the timer, turn it ON as described in step 2).

## About the timer switch

The timer switch can be assigned to another switch using the key assign function. Set the switch to the position that is most suitable.

## [DOWN]

## Down Timer

This timer can notify you of the model vehicle's battery or fuel consumption (running time).

The timer accepts settings of up to 99' 59" 90 in 1/10-second increments.

Once the down timer has run out, the up timer starts. This allows you to check the time elapsed since the timer ran out.  
(This timer has an alarm that sounds every minute.)

- Using the function select keys, move the cursor to [DOWN] in TIMER.

Turning the down timer ON/OFF

- Be sure that the cursor appears below LAP, and then press Inc.+ or Dec.- to set the timer ON.

Setting the down timer (minute)

- Press the ENTER key to move the cursor to (minute), and then set the timer by pressing the Inc.+ or Dec.- key.

Setting range 00' to 99' 01" increments (1-second increments)

(Default setting 00")

Setting the down timer (second)

- Press the ENTER key to move the cursor to (second), and then set the timer by pressing the Inc.+ or Dec.- key.

Setting range 00" to 59" 01" increments (1-second increments)

(Default setting 00")

Setting the down timer (1/10-second)

- Press the ENTER key to move the cursor to (1/10-second), and then set the timer by pressing the Inc.+ or Dec.- key.

Setting range 00 to 90 Increments of 10 (1/10-second increments)

(Default setting 00")

The timer will not function when it is set at 00" 00.

## IMPORTANT

When measurement ends, the timer's ON/OFF status changes to OFF. To re-start the timer, turn it ON as described in step 2).

## About the timer switch

The timer switch can be assigned to another switch using the key assign function. Set the switch to the position that is most suitable for you.



With the standard configuration, the down timer switch is set to SW3. Pressing SW3 starts measurement.

Each time you press SW3, the interval timer is restored to its preset value, and the countdown re-starts from that setting.

## 6. ENDING MEASUREMENT

End of measurement can be deactivated in two different ways.  
 From the menu, by simultaneously pressing the Inc.+ and Dec.- key.  
 By pressing and holding the switch for 3 seconds.

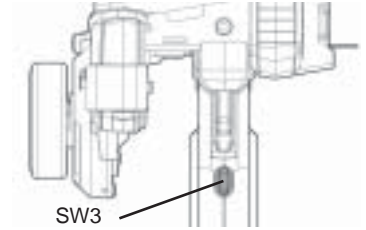

### IMPORTANT

\*When measurement ends, the timer's ON/OFF status changes to OFF. To re-start the timer, turn it ON as described in step 2).

\*About the timer switch

The timer switch can be assigned to another switch using the key assign function. Set the switch to the position that is most suitable for you.



## [REV] Servo Reversing



This function is to switch the direction of servo operation, and is used in situations when controls such as the steering wheel or throttle operate in the opposite direction .

Servo reversing can be individually adjusted for each of the 4 channels.

- Using the function select keys, move the cursor to [ST] in REV.
- Set the direction of servo operation by pressing the Inc.+ or Dec.- key.

Setting range NOR/REV  
 Standard setting NOR

- Make settings for the other channels in the same manner.





With engine-powered models, by opening the throttle a little, it makes it easier to start the engine. When using a channel other than 2CH for braking, a certain degree of braking can be applied independently of the trigger operation, making it possible to obtain safer engine starts. (This works when the S-POS switch is ON. Trigger operation starts at the point determined by the S-POS setting.

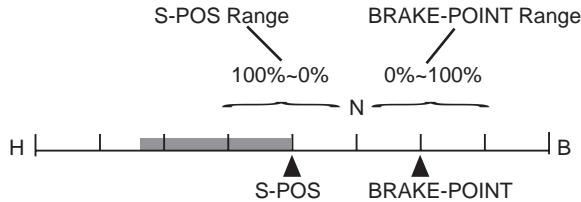

TIP When the S-POS switch is OFF, the S-POS position is at N (neutral).

- Using the function select keys, move the cursor to S-POS.

S-POS level setting

- Be sure that the cursor appears to the right of S-POS, and then set the S-POS value by pressing the Inc.+ or Dec.- key.

Turning the alarm ON/OFF

- Press the ENTER key to move the cursor to the ALARM, and then set the alarm by pressing the Inc.+ or Dec.- key. Ordinarily, leave the alarm ON.

BRAKE-LOCK setting

- Press the ENTER key to move the cursor to BRAKE-LOCK, and then choose the setting by pressing the Inc.+ or Dec.- key.

The BRAKE-LOCK setting is effective when channel 4 is selected, and the S-POS switch is ON or ACT selected, the brake channel is fixed at the LOCK-POINT value regardless of trigger operation.

LOCK-POINT setting

- Press the ENTER key to move the cursor key to LOCK-POINT, and then choose the setting by pressing the Inc.+ or Dec.- key.

Setting range 0% to 100%  
(Default setting 0%)

### IMPORTANT

About the S-POS switch

The S-POS switch can be assigned to another switch using the key assign function. Set the switch to the position that is most suitable for you.

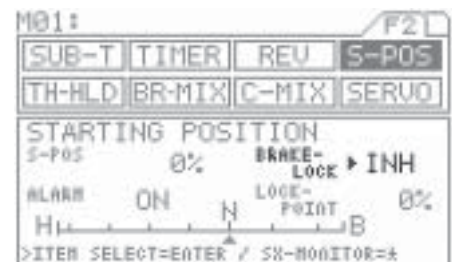
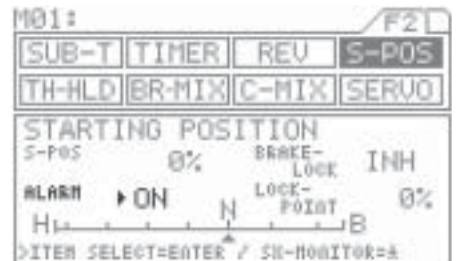



Throttle Hold allows you to stop the engine by pressing a button switch. This feature is generally used with R/C model boats and is also known as "ENGINE CUT".

The Throttle Hold function is used with engine-powered models to set the throttle slightly open and hold the engine at a steady idling rate. This prevents the engine from stopping during refueling.

The Throttle Hold is also used as an emergency brake for your model. By pressing the button switch, the trigger is disabled and remains disabled as long as the switch is depressed.

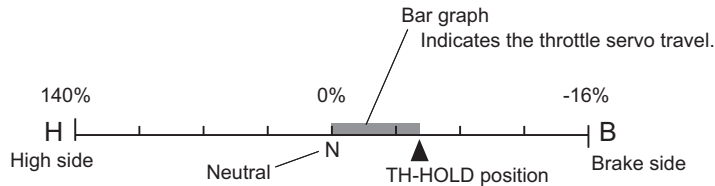

1. Assign TH-HLD to your preferred switch location by using the key assign function.

The throttle Hold function works only when the TH-HLD switch is depressed.

2. Using the function select keys, move the cursor to TH-HOLD.
3. Make sure that the cursor appears to the left of the percentage value and then set the TH-HOLD percentage by pressing the Inc.+ or Dec.- key.

Setting range -160% to 140% (Default setting 0%)

When TH-HLD is ON, the servo is locked to the preset position, regardless of the current trigger position.

4. Move the cursor to the right of TH-HOLD with the ENTER key and then select INH or ACT by pressing the Inc.+ or Dec.- key.

(INH) Normal throttle operation and throttle hold is active when a switch is depressed and held. Release switch to have normal throttle.

(ACT) Throttle hold is on until a switch is depressed and held for normal throttle operation. Release switch and throttle hold is on full time.

Setting HOLD-3CH (4 channel on)

5. Move the cursor to the right of HOLD-3CH with the ENTER key and then select the setting by pressing the Inc.+ or Dec.- key.

This setting is effective only when 3CH-BRAKE is active.

Setting HOLD-4CH

6. Move the cursor to the right of HOLD-4CH with the ENTER key and then select the setting by pressing the Inc.+ or Dec.- key.

This setting is effective only when 4CH is selected.



Brake Mixing function makes it possible to adjust servo mixing on models that require two servos for braking (ex. 1/5-scale engine-powered models). REV, EPA, SUB-T, and delay can be set independently for each channel. This provides flexibility for adjustment of different model types.

Brake trim is provided separately from throttle trim.

If you do not intend to use the brake on the 2nd channel (2CH), the brake side can be disabled.

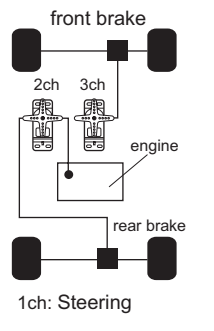
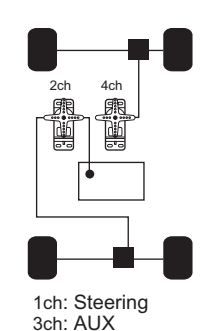
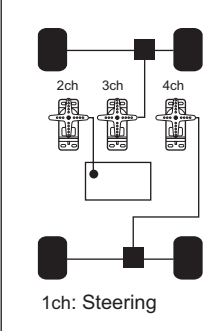
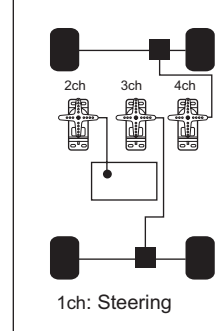

(TH-BRAKE CUT function)

* Settings for various model types				
Receiver type	3channel	4channel	4channel	4channel
3CH-BRAKE	ACT	INH	ACT	ACT
TH-BRAKE CUT	INH	INH	ACT	ACT

- Using the function select keys, move the cursor to BR-MIX.

Setting DELAY

- <2CH>

Be sure that cursor appears to the right of DELAY-2CH and then set the DELAY value by pressing the Inc.+ or Dec.- key.

<3CH>

Move the cursor to the right of DELAY-3CH with the ENTER key and then set the DELAY value by pressing the Inc.+ or Dec.- key.

<4CH>

Move the cursor to the right of DELAY-4CH with the ENTER key and then set the DELAY value by pressing the Inc.+ or Dec.- key.

Setting INH/ACT for 3CH-BRAKE

- Move the cursor to the right of 3CH-BRAKE with the ENTER key and then select INH or ACT by pressing the Inc.+ or Dec.- key.

This setting determines whether channel 3 is used as a brake or an AUX channel. It is a brake channel when ACT is selected.

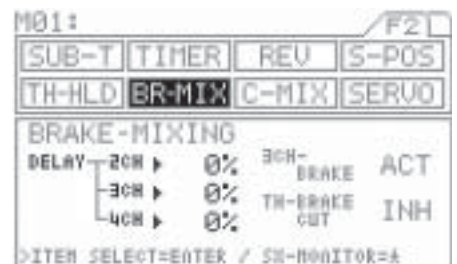

# Brake Mix (Cont)

Setting INH/ACT for TH-BRAKE CUT.

4. Move the cursor to the right of TH-BRAKE CUT with the ENTER key and then select INH or ACT by pressing the Inc.+ or Dec.- key.

If you do not intend to use the brake side of the throttle channel (2CH), servo operation can be disabled on the brake side by selecting ACT. This reduces the time lag of servo operation compared to using the throttle channel (2CH) for braking.



## IMPORTANT

Do not use the TH-BRK CUT function when 2CH is selected.

Be sure to set the menu as 4channel! If 2CH is selected, the function will have partial use.

Select 4CH (through the SET-UP menu) and be sure to set the 3CH-BRAKE first and then adjust the linkage.

Before adjusting REV, EPA, and SUB-T.

Compensation Mixing allows you to mix channels and to apply mixing to the channels themselves. On the master channel, you can select from direct data and data that includes calculations and trim.



There are two groups of C-MIX settings and you may use the two simultaneously. Using the offset function, you can move the origin for master mixing. You can easily turn the C-MIX function ON or OFF while driving (with the key assign switch). Graphic indication makes it easy to understand setting of mix.

Example) MASTER: ST1, L:10%, R:10%, SLAVE:TH, OFFSET:0

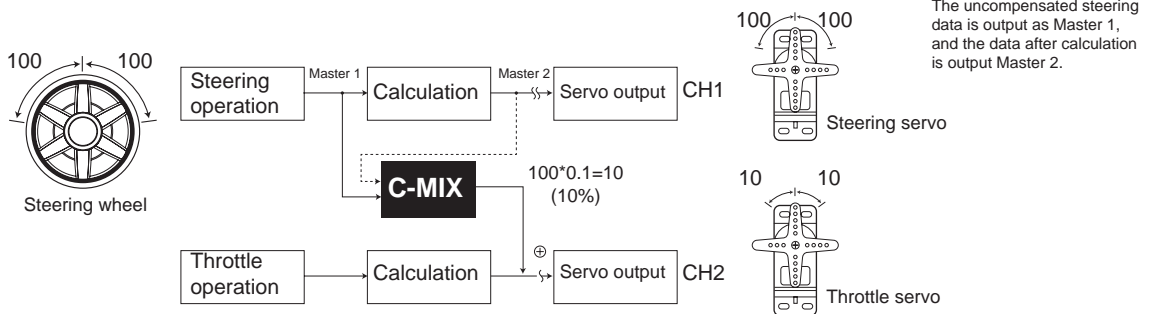

**NOTE**

With normal steering, control flow starts with steering wheel manipulation, proceeding through calculation, to servo output (CH1). With the C-MIX function, when the steering is moved by a certain amount (for example, 100 as shown in the figure above), 10% of that amount is applied to the CH2 servo, so that the CH2 servo moves by 10 as the steering servo moves by 100. The channel on which steering operation takes place is referred to as the "MASTER", and the channel that operates at 10% of the master level is referred to as the "SLAVE".

1. Using the function select keys, move the cursor to C-MIX1.
2. Make sure the cursor appears to the right of MASTER, and then set the master channel by pressing the Inc.+ or Dec.- key.

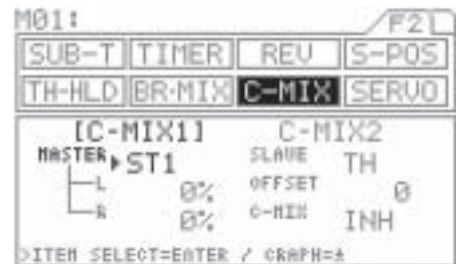

Setting	Name	Master output data
* ST1	Steering Master 1	Steering operation only
* ST2	Steering Master 2	Steering plus calculated amount of operation for SPEED, EXP, ARC, D/R, EPA, and trim (including sub-trim)
* TH1	Throttle Master 1	Throttle operation only
* TH2	Throttle Master 2	Throttle plus calculated amount of operation for SPEED, TR-CNT, BR-MIX, EXP, ARC, S-POS, EPA, and trim (including sub-trim)
* AUX1	AUX Master 1	AUX operation only
* AUX2	AUX Master 2	AUX plus calculated amount of operation for EPA

# C-Mix (Cont)

## 3. Setting the mixing level

### <Left side, High side>

Move the cursor to the right of L (or H) with the ENTER key, and then set the mixing level by pressing the Inc.+ or Dec.- key.

### <Right side, Brake side, Low side>

Move the cursor to the right of R (or B or L) with the ENTER key, and then set the mixing level by pressing the Inc.+ or Dec.- key.

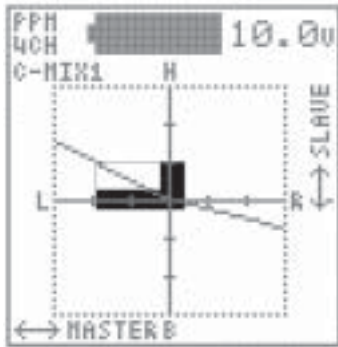
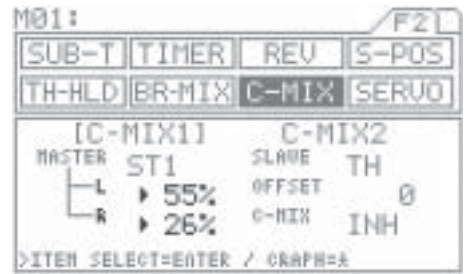

Slave is vertical axis

Graph display for L side setting (55%)

Mixing level bar graph for slave (Mixing level varies as indicated according to slope of graph.)

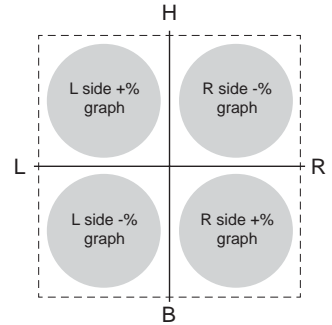

Bar graph of master operation

Graph display for R side setting (26%)

Master is horizontal axis

The ★ key displays the graph in the constant display area.

## 4. Setting the SLAVE channel

Move the cursor to the right of SLAVE with the ENTER key, and then select the SLAVE channel by pressing the Inc.+ or Dec.- key.

- \* Setting range ST, TH, AUX, BR
- \* The AUX channel always becomes the slave of the third channel, regardless of the INH/ACT setting of 3CH-BRAKE.

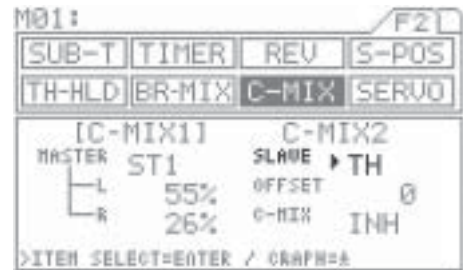

## 5. Setting the amount of OFFSET

Move the cursor to the right of OFFSET with the ENTER key, and then set the amount of offset by pressing the Inc.+ or Dec.- key.

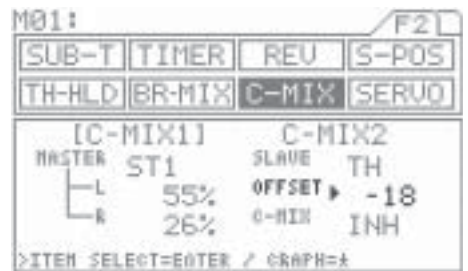

### Using the Offset Function

#### (1) Correcting Master 2 trim deviation using OFFSET

Master ST3, SLAVE TH

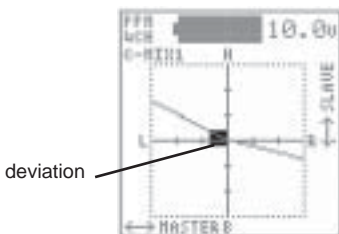

\* When trim deviation appears in graph as shown above with steering at neutral position.

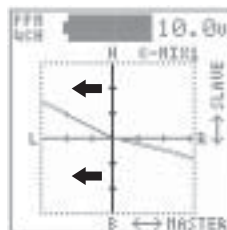

\* Adjust offset value in negative direction, moving vertical axis to left and erasing bar graph.

Bar graph shows extent of steering operation



\* By adjusting to the point where deviation disappears, the steering neutral position can become the origin for mixing.

# C-Mix (Cont)

- (2) Adjusting the master mixing origin so that no mixing occurs when the dial (AUX) is turned full to the left, but maximum mixing occurs when it is turned full to the right.

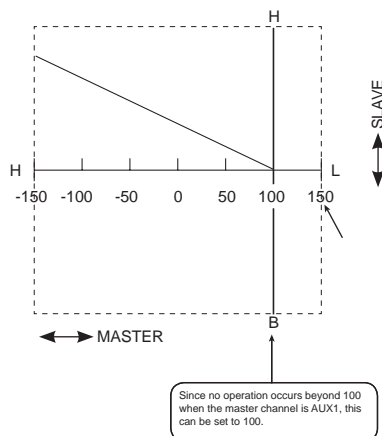
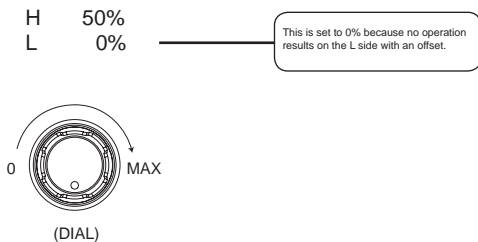

## 6. Setting INH/ACT for C-MIX

Move the cursor to the right of C-MIX with the ENTER key, and then select INH or ACT by pressing the Inc.+ or Dec.- key.



## IMPORTANT

The INH/ACT setting of C-MIX

The INH/ACT setting of C-MIX can be changed using the key assign switch as well as through the menus. Using this function, adjustment is possible from any menu; C-MIX "ON" or "OFF" can be easily adjusted with the selected switch even during operation.

## NOTE

When the slave and master are both on the same channel, mixing takes place within the channel itself. This causes the steering angle to increase for positive values and to decrease for negative values. You can locate the best steering response, for your driving, by switching mixing ON and OFF.



Servo Monitor function displays output levels of the various channels, in bar graph form, allowing you to monitor model operation in a virtual manner. Using this feature, while making function setting changes, makes it easier to understand adjustments.

The graph can be displayed in the constant display area, allowing it to be viewed while making settings of other features.

(Some menus cannot be displayed.)



1. Using the function select keys, move the cursor to SERVO.
2. Opening the constant display area  
 You can open the constant display area from any menu by pressing the ★ key. Pressing the ★ key a second time returns the display to normal.

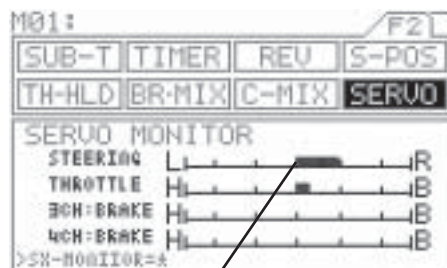

Bar graph display

Constant display area

(Example) BATT menu

Menus you can open

- |           |            |
|-----------|------------|
| F1        | F2         |
| (1)D-RATE | (1)SUB-T   |
| (2)EPA    | * (2)TIMER |
| (3)EXP    | (3)REV     |
| (4)ARC    | (4)S-POS   |
| (5)SPEED  | (5)HOLD    |
| (6)ALB    | (6)BR-MIX  |
| (7)TR-CLL | (7)SERVO   |

\* The graph cannot be displayed from the [LAP] menu.

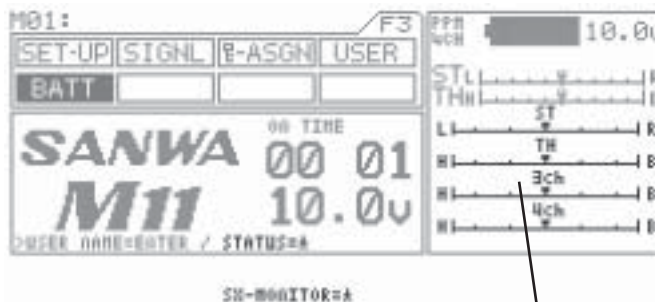

Servo monitor display

NOTE

(REV) operation is not reflected in the servo monitor. Indication of the graph only shows the direction of the input control such as wheel and trigger movement.

Set-Up section explains how to adjust the LCD contrast (darkness and lightness), turn the vibrator ON/OFF, and select between 2CH/4CH, backlight ON/OFF/Auto OFF, backlight color set as blue or white.



1. Using the function select keys, move the cursor to SET-UP.

2. CONTRAST setting

Move the cursor to the right of CONTRAST with the ENTER key or ★ key, and then adjust LCD contrast (darkness) by pressing the Inc.+ or Dec.- key.

- \* Setting range 0% to 100%
- \* Standard setting 80%

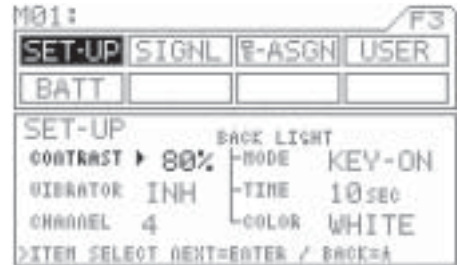

3. Setting INH/ACT for VIBRATOR

Move the cursor to the right of VIBRATOR with the ENTER key or ★ key, and then select INH or ACT for the vibrator by pressing the Inc.+ or Dec.- key.

- \* When ACT is selected, the vibrator buzzes at the same time as the timer alarm or the battery alarm sounds. It also buzzes when the Main power is turned on.

4. Making the CHANNEL setting

Move the cursor to the right of CHANNEL with the ENTER key or ★ key, and make the channel selection by pressing the Inc.+ or Dec.- key.

- \* 2CH
  - ch1 Steering (ST)
  - ch2 Throttle (TH)
- \* 4CH
  - ch1 Steering (ST)
  - ch2 Throttle (TH)
  - ch3 AUX or brakes (BR)
  - ch4 Brakes (BR)



5. Making the BACK LIGHT setting

<MODE>

Move the cursor to the right of MODE with the ENTER key or ★ key, and then select the mode by pressing the Inc.+ or Dec.- key.

- \* KEY-ON-ON The backlight goes OFF when the time set for TIME elapses without any menu key operation.
- \* ALWAYS The backlight remains constantly ON.
- \* OFF The backlight remains constantly OFF.

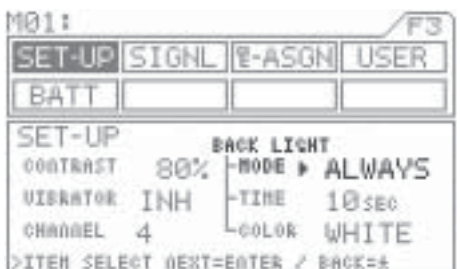
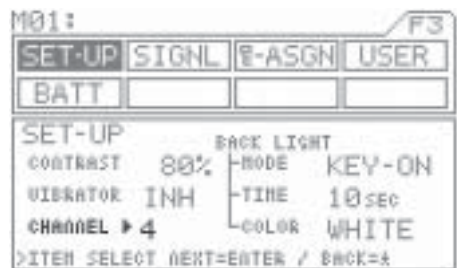

# Set-up (Cont)

## <TIME>

Move the cursor to the right of TIME with the ENTER key or ★ key, and then set the time by pressing the Inc.+ or Dec.- key.

- \* This will not appear unless MODE is set to KEY-ON.
- \* Setting range           1SEC to 30SEC
- \* Standard setting       10SEC

## <COLOR>

Move the cursor to the right of COLOR with the ENTER key or ★ key, and then select the backlight color by pressing the Inc.+ or Dec.- key.

- \* WHITE                   White backlight
- \* BLUE                    Blue backlight



Signal Function allows you to set the key operation tone and alarm tones independently and in different tonal scale

Tonal scale, of each key operation or alarm, can be set differently for separate parts. This means tonal scale can be set separately for the first half and last half tones.

Tones can be selected from among 10 tones, providing a total of 100 pattern combinations for the first half and last half of signals.



- Using the function select keys, move the cursor to SIGNL.

- Command signal (COMMAND) tone setting  
Move the cursor to the right of COMMAND with the ENTER key or ★ key, and then set the tone for the first half of the signal by pressing the Inc.+ or Dec.- key.

Next, move the cursor one position to the right with the ENTER key, and then set the tone for the last half of the signal by pressing the Inc.+ or Dec.- key.

- \* Setting range S01 to S10 and MUTE (silent)
- \* Standard setting First half: S10, Last half: S10
- \* The command signal sounds when menu keys are pressed.



- Making pre-alarm (PRE-ALM) tone settings  
Move the cursor to the right of PRE-ALM with the ENTER key or ★ key, and then set the tone for the first half of the signal by pressing the Inc.+ or Dec.- key

Next, move the cursor one position to the right with the ENTER key, and then set the tone for the last half of the signal by pressing the Inc.+ or Dec.- key.

- \* Setting range S01 to S10 and MUTE (silent)
- \* Original setting First half: S10, Last half: S10
- \* The pre-alarm signal is used with the lap timer.



- Making down alarm (DOWN) tone settings  
Move the cursor to the right of DOWN with the ENTER key or ★ key, and then set the tone for the first half of the signal by pressing the Inc.+ or Dec.- key.

Next, move the cursor one position to the right with the ENTER key, and then set the tone for the last half of the signal by pressing the Inc.+ or Dec.- key.

- \* Setting range S01 to S10 and MUTE (silent)
- \* Standard setting First half: S05, Last half: S05
- \* The down alarm signal is used with the down timer.

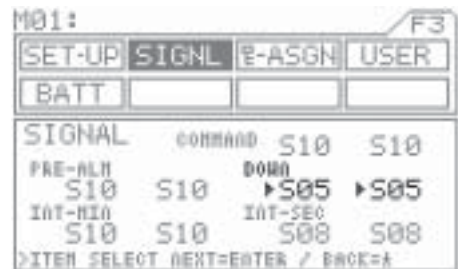

# Audio Signal Sound (Cont)

5. Making interval minute alarm (INT) tone settings  
Move the cursor to the right of INT-MIN with the ENTER key or ★ key, and then set the tone for the first half of the signal by pressing the Inc.+ or Dec.- key.

Next, move the cursor one position to the right with the ENTER key, and then set the tone for the last half of the signal by pressing the Inc.+ or Dec.- key.

- \* Setting range S01 to S10 and MUTE (silent)
- \* Standard setting First half: S10, Last half: S10
- \* The interval minute alarm is used with the minutes portion of the interval timer.





6. Making interval seconds alarm (INT) tone settings  
Move the cursor to the right of INT-SEC with the ENTER key or ★ key, and then set the tone for the first half of the signal by pressing the Inc.+ or Dec.- key.

Next, move the cursor one position to the right with the ENTER key, and then set the tone for the last half of the signal by pressing the Inc.+ or Dec.- key.

- \* Setting range S01 to S10 and MUTE (silent)
- \* Standard setting First half: S08, Last half: S08
- \* The interval seconds alarm is used with the second portion of the interval timer.



## IMPORTANT

- If two signals overlap, they sound as a single tone. The longer tone may not sound.
- If you do not want a signal tone, select MUTE for both the first and last halves of the tone. If you mute only half the tone, the other half will sound.
- The buzzer icon  displayed in the constant display area changes to  if both halves of the command setting are muted.

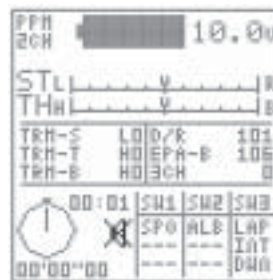

Functions and trim settings (adjustments to function settings) can be assigned to SW1-SW3, trimmers TRM1-TRM5, and the dial control on the transmitter.



Locations of switches and trimmers

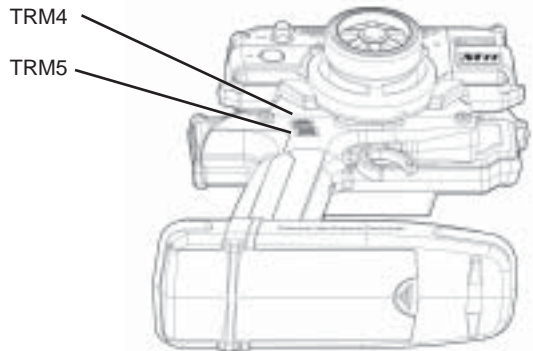
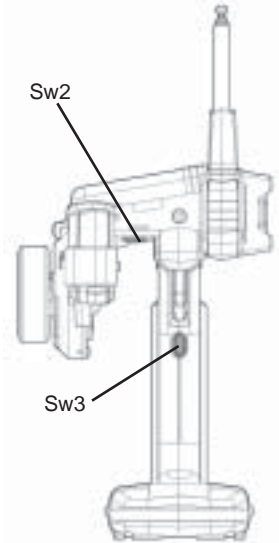
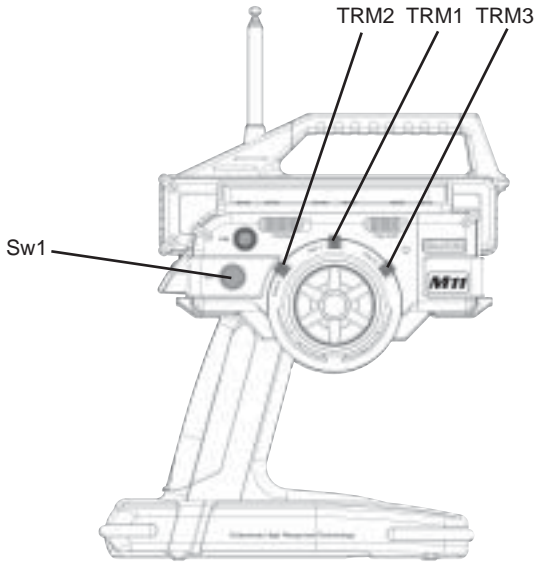

NOTE: Functions originally assigned factory default.

- |                               |                        |
|-------------------------------|------------------------|
| TRM1: Steering trim           | SW1: Starting position |
| TRM2: Throttle trim           | SW2: Anti-lock braking |
| TRM4: Dual rate               | SW3: Timer             |
| TRM5: End point adjust, brake |                        |

**[SW]** Key Assign Switch

ON/OFF control of various functions can be assigned to SW1-SW3, making it easy to use those functions during operation.

Up to three functions (FUNC1-FUNC3) can be assigned to a single switch, allowing all of those functions to be controlled at once.



Up to three functions can be assigned to a single switch.

Here, LAP-T, INT-T, and DWP-T can all be turned ON/OFF together.

When the function is turned ON, character will be displayed.

Function status is also displayed in the constant display area.



# Switch / Trim Assignment (Cont)

- Using the function select keys, move the cursor to [SW] in  $\bar{\text{E}}$ -ASGN.
- Using the  $\star$  key or the ENTER keys, move the cursor to the switch to be assigned, and then assign functions to the switch by pressing the Inc.+ or Dec.- key.



\* Assignable functions

Function	Menu screen	Constant display area	Factory default
Exponential steering	EXP-ST	EXS	
Exponential throttle	EXP-TH	EXT	
Adjustable rate control, steering	ARC-ST	ARS	
Adjustable rate control, throttle	ARC-TH	ART	
Speed steering	SPD-ST	SPS	
Speed braking	SPD-BR	SPB	
Anti-lock braking	ALB	ALB	[SW2]
Traction control	TR-CTL	TRC	
Lap timer	LAP-T	LAP	[SW3]
Interval timer	INT-T	INT	[SW3]
Down timer	DWN-T	DWN	[SW3]
Starting position	S-POS	SPO	[SW1]
Starting position, brake lock	BR-LCK	BRL	
Throttle hold	TH-HLD	HLD	
Compensation mixing 1	C-MIX1	CX1	
Compensation mixing 2	C-MIX2	CX2	

## [TRIM]

## Trim Assignment

Setting this function can be varied by using trimmers TRM1 to TRM5 and the dial.

The size of the STEP can be set, and each setting width can be changed, by pressing a key.

Functions can be assigned to any of 6 positions, allowing you to choose the controls that are best suited to your situation.

The values of function settings, made using key assign trim, can be displayed in the constant display area and confirmed from any menu.

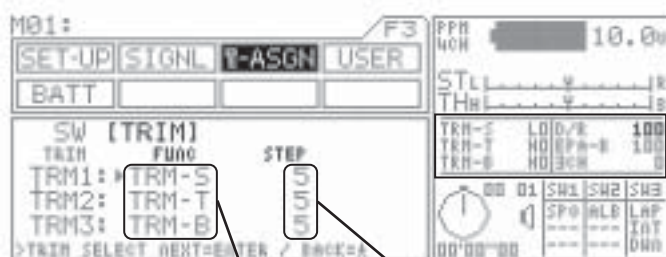

Settings appear

Status of settings is also displayed in the constant display area.

Function setting

Number of steps (size of change)

# Switch / Trim Assignment (Cont)

1. Using the function select keys, move the cursor to [TRIM] in **F**-ASGN.

2. Function selection

Using the **★** key or the ENTER keys, move the cursor to the trimmer function to be selected, and then select a function by pressing the Inc.+ or Dec.- key.

3. Setting the number of steps

Using the **★** key or the ENTER keys, move the cursor to the STEP for the trimmer you want to adjust, and then set the number of steps by pressing the Inc.+ or Dec.- key.

\* The number of steps determines the amount of trim that is applied for one click of the trimmer switch.

\* Selectable functions and step ranges



Function	Menu screen	Constant display area	Factory default
Dual rate	D/R	1 - 10	[SW4]
End point adjustment, brake	EPA-B	1 - 10	[SW5]
Exponential steering	EX-S	1 - 10	
Exponential throttle, high	EX-H	1 - 10	
Exponential throttle, brake	EX-B	1 - 10	
Adjustable rate control, steering rate	AR-S-R	1 - 10	
Adjustable rate control, steering point	AR-S-P	1 - 10	
Adjustable rate control, throttle high rate	AR-H-R	1 - 10	
Adjustable rate control, throttle brake rate	AR-B-R	1 - 10	
Adjustable rate control, throttle high point	AR-H-P	1 - 10	
Adjustable rate control, throttle brake point	AR-B-P	1 - 10	
Speed steering forward	SP-S-F	1 - 10	
Speed steering return	SP-S-R	1 - 10	
Speed steering point	SP-S-P	1 - 10	
Speed brake forward	SP-B-F	1 - 10	
Speed brake point	SP-B-P	1 - 10	
Anti-lock braking point	ALB-PT	1 - 10	
Anti-lock braking stroke	ALB-ST	1 - 10	
Anti-lock braking lag	ALB-LG	1 - 10	
Anti-lock braking speed	ALB-SP	1 - 10	
Traction control, traction	TRC	1 - 10	
Traction control, delay	TRC-DY	1 - 10	
Traction control, point	TRC-PT	1 - 10	
Starting position	SPOS	1 - 10	
Throttle hold	HLD	1 - 10	
Brake mixing delay, 2CH	BM-2CH	1 - 10	
Brake mixing delay, 3CH	BM-3CH	1 - 10	
Brake mixing delay, 4CH	BM-4CH	1 - 10	
Compensation mixing 1, offset	CX1-OF	1 - 10	
Compensation mixing 1, high	CX1-Hi	1 - 10	
Compensation mixing 1, low	CX1-Lo	1 - 10	
Compensation mixing 2, offset	CX2-OF	1 - 10	
Compensation mixing 2, high	CX2-Hi	1 - 10	
Compensation mixing 2, low	CX2-Lo	1 - 10	
Steering trim	TRM-S	1 - 10	[TRM1]
Throttle trim	TRM-T	1 - 10	[TRM2]
Brake trim	TRM-B	1 - 10	
3CH (AUX)	3CH	1 - 10,20,50,100,200	

The name of the M11's owner can be registered.

Owners name can consist of up to 12 letters, numerals, or symbols.



1. Using the function select keys, move the cursor to USER.
2. Using the ★ key or the ENTER key, move the cursor (" ") to the point when you want to enter text.
3. Select a character by pressing the Inc.+ or Dec.- key.
  - \* Setting range A-Z, a-z, 0-9, symbols, space
4. Repeat steps 2) and 3) for each subsequent character.



## NOTE

A group of characters can be scrolled in the sequence A->a->0->!->space-> by simultaneously pressing the Inc.+ and Dec.- keys.

When entering a character in a position occupied by a space, the preceding character can be selected by first pressing the Dec./+ key. This is useful when repeating same characters. \* Under the BATT menu, indication of the display can be switched between display of the M11 logo and the user name by using the ENTER key.

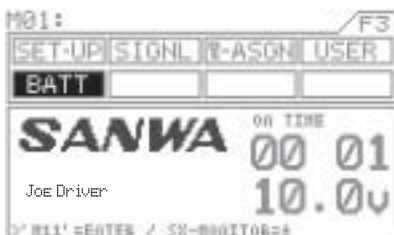

In order to check the model vehicle's linkage during a race or a situation when the radio transmission is prohibited, setting changes can be done using the DSC cable.

### Using the DSC cable with DSC switch harness equipped on Gas powered type models

1. Connect the supplied DSC cable to the DSC jack at the opposite side of the wheel of the M11.

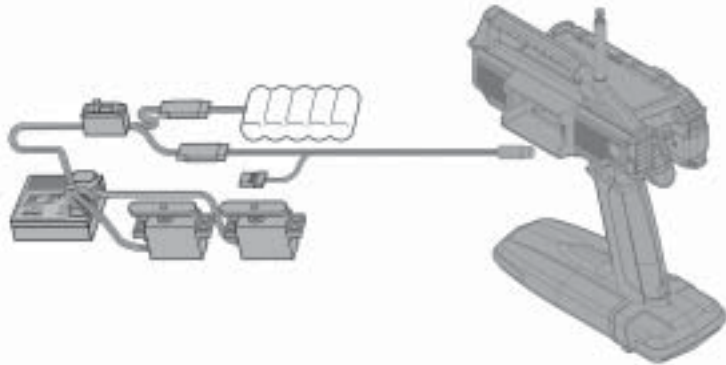

(\* To prevent any possible risk from other radio transmissions, remove the receiver crystal.)

2. Connect the DSC cable (female connector) to the charging connector (male) on the DSC switch harness.
3. Turn on the Display switch of the M11 than turn on the power of the DSC switch harness.

### Using the DSC Switch Harness with an FET Speed Controller

1. Connect the supplied DSC cable to the DSC jack at the opposite side of the wheel of the M11.

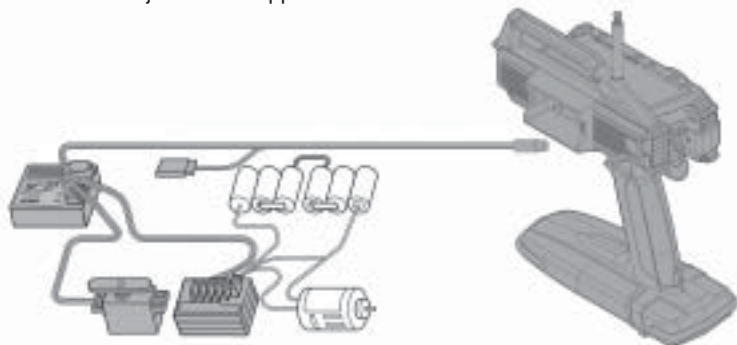

(\* To prevent any possible risk from other radio transmissions, remove the receiver crystal.)

2. Connect the DSC Cable's male connector to the Battery/DSC channel on the receiver.
3. Turn on the Display switch of the M11 than turn on the Power of the ESC 's switch harness.
4. Ready for DSC operation.

#### CAUTION

Never turn on the transmitter power switch while using the DSC harness. RF activation of radio transmission may cause trouble for others.

When using the DSC cable, connect the power battery to the E/P car and/or connect the receiver battery to receiver for G/P models.

When using the DSC cable, be certain that the transmitter battery is installed.  
After using the DSC cable, be sure to disconnect the DSC cable at both ends.

# Receiver Connection and Installation

## Connecting the Receiver

The RX-311 or RX-211 are the receiver made for use with Z-type connectors.

### Connector locations on receiver

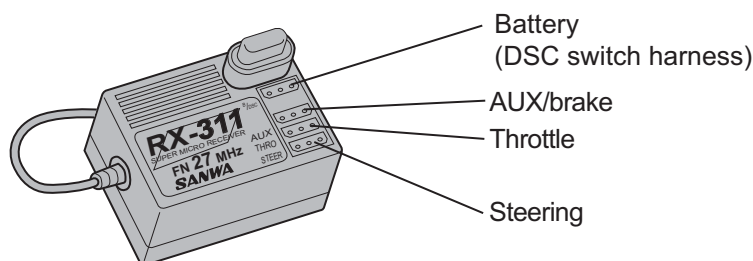

#### CAUTION

- Use only genuine SANWA FM Crystals.  
Use of crystals other than those specified may result in frequency errors and possible runaway operation.
- There is a danger of runaway operation, if connectors shake loose while driving. Make sure that receiver, servo, and switch connectors are securely fitted.
- A danger of runaway operation exists with shorter antennas, due to reduced receptivity. Do not cut any length of antenna wire.
- The receiver susceptible to vibration, shock and moisture. Take appropriate measures to protect against vibration and water. Failure to take appropriate measures could result in runaway operation or to damage to the receiver.
- Keep the receiver antenna away from motors, battery, and ESC and make sure that antenna stick out from the model vehicle vertically.
- When installing the receiver, don't let it come in contact with any carbon chassis or metal chassis. Keep them away from receivers.
- The frequency of receiver crystals will drift with cumulative vibration and shock. Therefore, periodic replacement is necessary.
- Contact between metal parts mounted on a model can result in electrical noise, adversely affecting receiver performance and possibly resulting in runaway operation or damaged to your model vehicle.
- With electrically-powered models, be sure to fit the motor with a noise suppression capacitor. Without a noise suppression capacitor, excessive noise generation can cause runaway operation. And/or result of damage to the model vehicle.
- Use rubber anti-vibration absorbers with servos. Direct transmission of engine vibration to servos can cause servo trouble and possibly result in runaway operation with damaging your model vehicle.
- Use only genuine SANWA transmitters, receivers, servos, ESC, transmitter/receiver batteries, and crystals.
- \* The manufacturer disclaims all responsibility for damages resulting from use of components other than genuine SANWA components.
- \* The M11 can be switched between 2ch and 4ch operation.  
Note that 4ch operation is not possible when using the RX-311 or RX-211 receivers were being used.

# Troubleshooting

Symptom		Cause	Remedy
Does not Transmit		Batteries low or not fully charged.	Replace or charge batteries
Power sometimes goes off		Intermittent connector contact.	Contact Airtronics for service.
Alarm does not stop	Alarm gives off a series of beeps.	Battery voltage low.	Replace or charge transmitter batteries.
	Alarm gives off continuous double beep.	S-POS switch is in the ON position.	Turn S-POS switch to the OFF position.
	Alarm gives off a periodic double beep.	The interval timer is ON.	Check the INT timer.
No key sound when keys are pressed.		Command signals are disabled.	Check command signal settings.
No change in display when keys are pressed.		Key lock switch is ON	Turn key lock switch OFF.
Servo movement is slow	A negative value is set in the servo speed.		Check servo speed settings
	Low battery		Replace or charge transmitter batteries.
	Linkage stiff		Adjust linkage to work freely.
Left and right steering angles are different even if settings are the same.		Trim or Sub Trim not centered	Align trim and Sub Trim.
Servo will not move to the end of its range.		D-RATE and EPA settings are too large.	Reset linkage on the servo for more travel from servo and reset settings.
Servo does not move when using trim.		Trim is outside of operational range.	Reset trim to 0 and center the servo horn and linkage on servo.
Lap timer and interval timer do not function		Timers are set in the OFF position	Turn timers ON.