

# M18

Instruction Manual



**SANWA**

## Table of Contents

### Page

1. Table of Contents
2. Features
3. Connectors
4. Battery Charging, Handle Position,  
Steering Wheel Tension Adjustment
5. Replacing Crystals
6. Transmitter Features and Controls
7. Transmitter Features and Controls
8. Display Panel
9. Display Panel Operation
10. Battery, Timer, Battery Alarm
11. Dual Rate
12. Steering End Point Adjustments
13. Throttle End Point Adjustments
14. Digital Trim
15. Steering Exponential
16. Throttle Exponential
17. Steering Servo Speed
18. Throttle Servo Speed
19. Model Name
20. Model Copy, Model Clear
21. Sub Trim
22. Trim Rate, Trim Reset
23. Response Switch
24. Lap Timer
25. Lap Timer cont.
26. Interval Timer
27. Servo Reverse, Starting Position
28. Command Signal, LCD Contrast, Key Lock
29. Direct Servo Controller
30. Position of Receiver Connectors

## M8 System Features

- **Narrow Band FM Receiver and Transmitter:** For the best possible radio link between the transmitter and your model.
- **New SANWA "Z" Servo Connectors:** Allows connecting to components of most other brands without plug changes.
- **Transmitter RF Frequency Modules:** Allows quick and positive channel and / or band changes, even between heats.
- **Three Channel Operation:** For additional scale functions.
- **Advanced Case Ergonomics:** For comfortable operation, well balanced with perfect wheel and grip alignment.
- **Adjustable Grip Length:** Adjustable for any hand width.
- **Interchangeable Grip Position:** For left or right handed users.
- **Steering Wheel Tension:** Adjustable to exact point desired.
- **Rechargeable Battery:** Drop-in NiCd battery available.
- **Transmitter Battery Monitor:** Displays battery voltage digitally in 0.1 volt increments from 8.0 to 13.1 volts
- **Transmitter Battery Alarm:** Provides audio beeps when battery drops to 9.1 volts, steady tone when it drops to 8.9 volts.
- **Large Display Panel:** High visibility, large characters.
- **Dual Rates:** Available on both steering and throttle channels.
- **Exponential:** Available on both steering and throttle channels.
- **End Point Adjustments:** Available on both steering and throttle channels.
- **Digital Trim:** One degree trim changes possible while running. Includes Sub Trim, Trim Rate, and Trim Reset functions.
- **Servo Speed:** Steering and throttle servo speed variable.
- **Ten Model Memory:** Stores all operational data for 10 different models. Includes Model Copy and Model Clear functions.
- **Response Switch:** Adjust servo response time while under way.
- **Digital Timer:** Multipurpose programmable timer can be set for total ON time, lap time, or as interval timer.
- **Servo Reverse:** Sets direction of steering and throttle servo.
- **Starting Position:** Exclusive feature for glow engine powered models, sets the throttle at high idle for easier starting.
- **Command Signal:** Selects one of ten different tones to be heard during any trim and function key operations.
- **LCD Contrast:** Sets the brightness of the screen at the best level for different ambient lighting conditions.
- **Key Lock:** Turns off programming keys to prevent accidental change or loss of stored data by inadvertent operation.
- **Direct Servo Controller:** Allows setting of model linkages and all transmitter data without actual transmission taking place.
- **Fully Compatible:** With all SANWA accessories and most of those available from all major R/C equipment manufacturers.

## Connectors

### CAUTION!

- Your M8 system uses **SANWA New "Z" Connectors**. The receiver is blue in color and should be used only with "Z" connector equipped servos, speed control, switch harness or batteries.
- The receiver and all "Z" configured components use a different pin polarity than previous servos, speed controllers, switch harnesses and batteries and should not be used together.

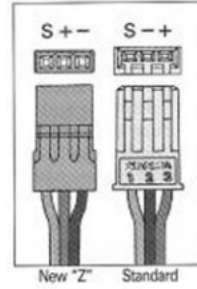

To use your "Z" connector receiver with previous servos, etc. Conversion cable(S→Z) must be used or new "Z" connectors installed by our service department.

To use previous receivers with "Z" connector servos, etc. Conversion cable(Z→S) must be used.

#### SANWA Receiver to SANWA "Z" Servo

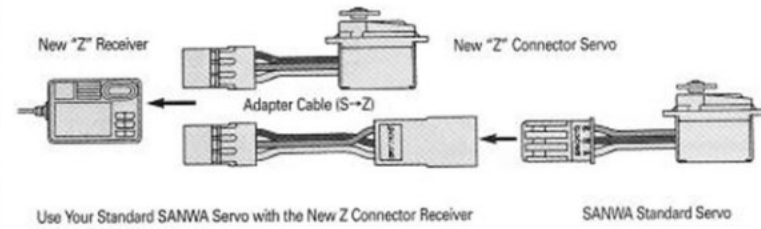
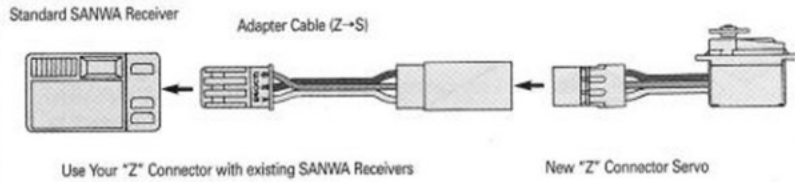

### NI-CD BATTERY CHARGING

- Before connecting the charger, both transmitter and receiver power switches must be in the "OFF" position.
- When using Ni-Cd batteries for the first time or they have not been used for long periods, they may not accept a full charge. If so, they should be discharged and re-charged two or three times.

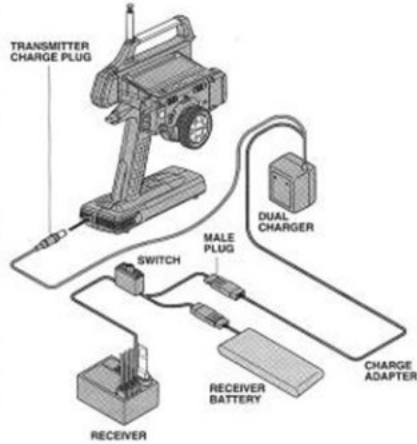

Whenever a quick charger is used, the charge rate should not exceed one ampere.

### HANDLE POSITION:

You will find the M8 to be especially well balanced, with the wheel and trigger aligned to maximize driving precision.

### Adjusting the handle position:

- (1) Remove the RF module.
- (2) Loosen the four screws indicated on the back side of the transmitter, pull down on the handle.
- (3) With the handle positioned as desired, retighten the screws.

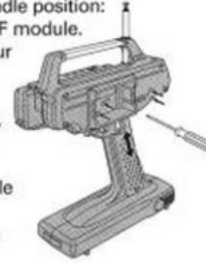

### Switching left to right hand handle position:

If you are left handed, the handle may be rotated as follows:

- (1) Remove the RF module
- (2) Remove the four screws indicated on the back side of the transmitter.
- (3) Pull down and remove the handle from the top section. It only needs to clear the top, use care not to pull the connecting wires loose.
- (4) Rotate the handle 180 degrees and replace it back in the top section.
- (5) Install and tighten the four screws.

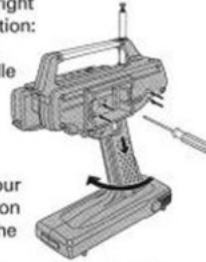

### STEERING WHEEL TENSION ADJUSTMENT:

The steering wheel tension is factory set to the softest position. It can be adjusted using a 1.5mm hex wrench as indicated; turn the screw in to increase tension.

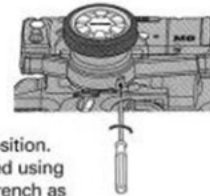

## REPLACING CRYSTALS

### Transmitter:

- (1) Remove the crystal cap, remove the installed crystal and replace it with the new one.
- (2) To change the band, it is necessary to change the transmitter RF module.
- (3) When changing the module, assure that it is firmly installed, improper or loose installation will cause malfunctions.
- (4) Be sure to use the crystal cover to protect the crystal.
- (5) Your transmitter uses SANWA M-8 RF Module (TM-131CW). They are not interchangeable with other modules.

### Receiver:

- (1) Remove the installed crystal and replace it with the new one.
- (2) Receiver frequency changes are possible only within the respective band. To change bands you must replace the receiver.
- (3) Be sure to install the silicone ring to protect the crystal from vibration and damage.

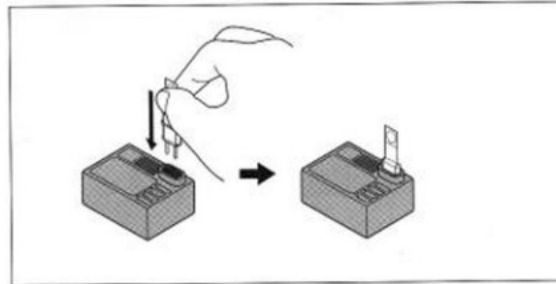

## Transmitter Features And Controls

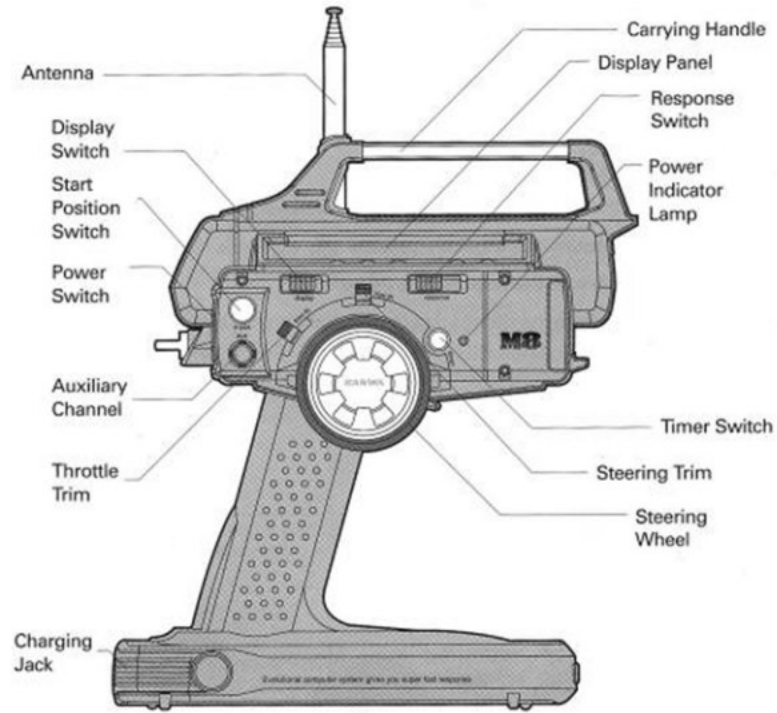

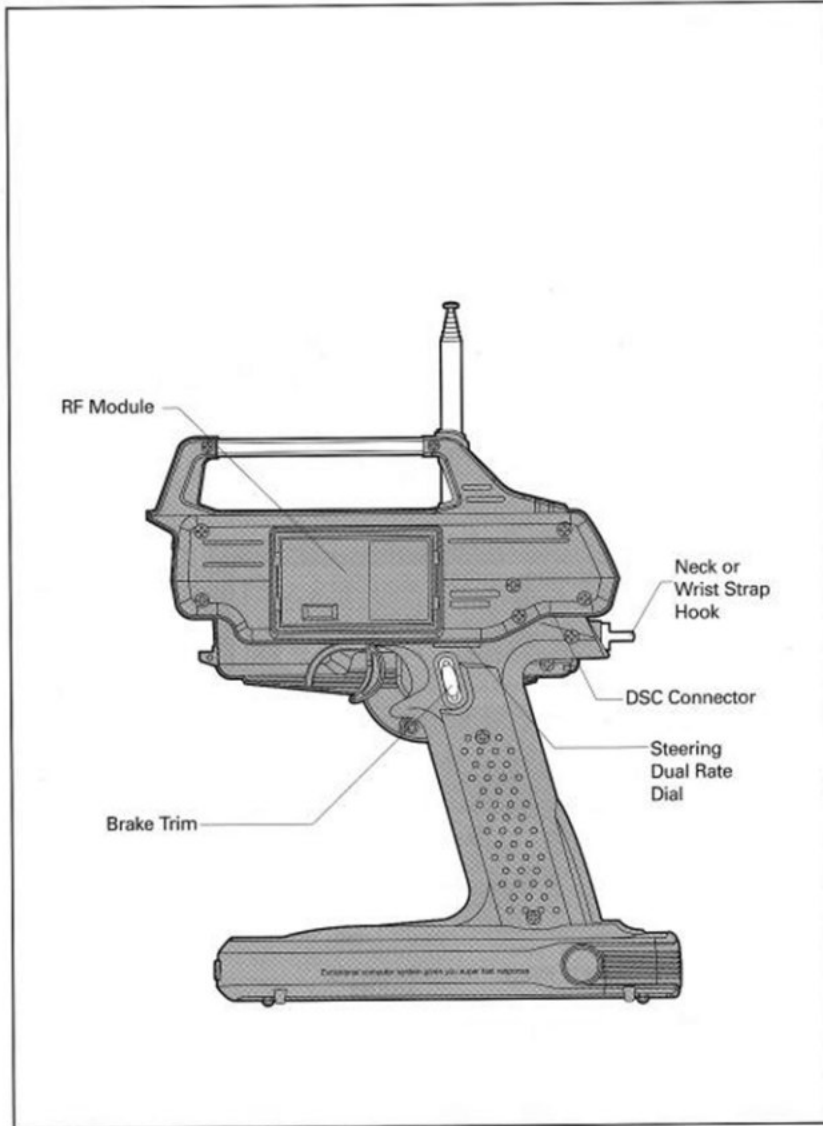



### DISPLAY PANEL

Your M8 transmitter's large multiple display shows it's many possible functions at a glance. It enables the various functions to be set into its extensive memory, stored, and copied, and provides instant confirmation of all data entered.

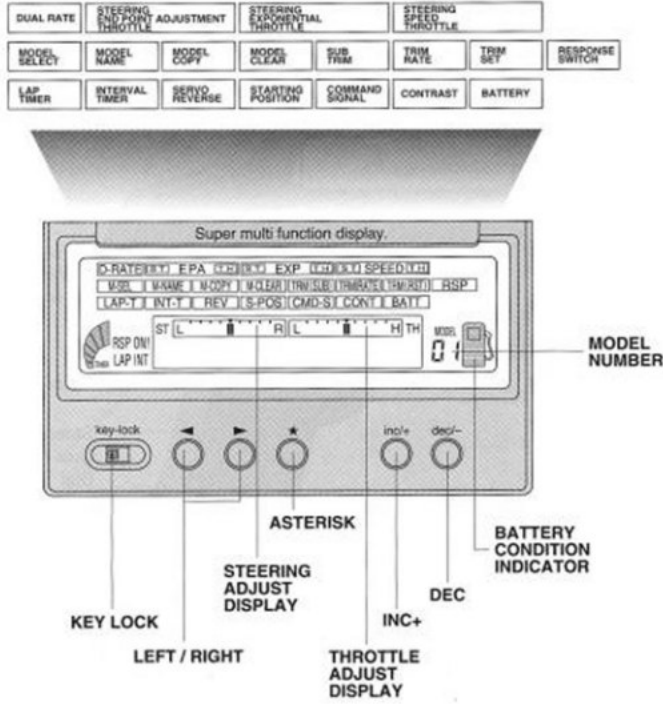

## BASIC OPERATION OF THE DISPLAY PANEL

(1) Using the Function Select Keys < >, move the cursor left or right, up or down, to the desired function name. Pressing the < > Keys at the same time moves the cursor up and down.

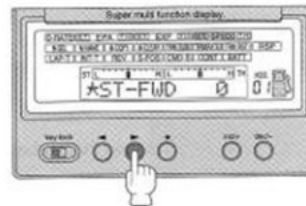

(2) When the display shows an asterisk (\*), you can scroll the menu for further functions.

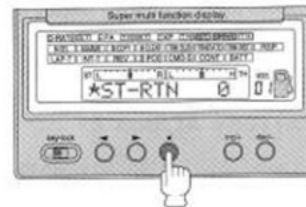

(3) The indicated value can be adjusted with the Inc.+ or Dec.- Keys. Depress both the Inc.+ and Dec.- Keys to reset to the original value.

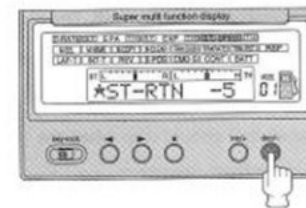

### BATT (BATTERY)

The Battery Voltage is indicated in 0.1V steps from 8.0V to 13.1V.

### TIMER OPERATION

Under BATT, depressing the Inc.+ and Dec.- Keys simultaneously will reset the timer to indicate the transmitter operating time so that its battery life can be estimated.

Note: The transmitter operating time includes also the time the display is operational.

### BATTERY ALARM

An audio alarm will sound when the transmitter's battery voltage drops to 9.1V. The alarm can be stopped by depressing any of the keys. The alarm will re-start when the voltage drops an additional 0.2V. Operation of the transmitter should stop when the second alarm is heard and the battery must be replaced or recharged. Continued operation will result in an out of control model.

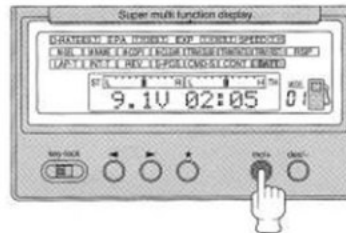
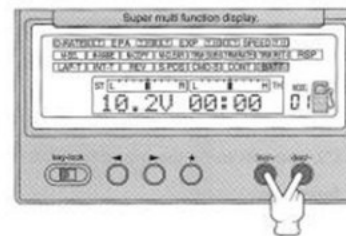
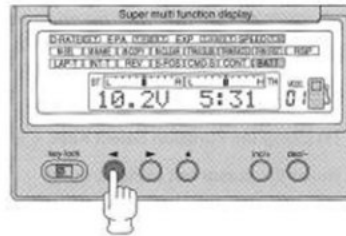

**D-RATE (STEERING DUAL RATE)**

This function is recommended to correct an under- or over-steering condition. It can be adjusted with the Steering Dual Rate Dial on top of the handle while driving your model.

- (1) First adjust the steering to neutral
- (2) Set the Steering Dual Rate Dial to its center.

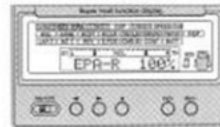

Dual Rate Dial



- (3) Depress the Function Select Key and move the cursor to D- RATE.

- (4) Turn the Steering Wheel clockwise or counter-clockwise and depress the Inc.+ or Dec.- Key until the steering linkage hits its stops, then decrease the indicated reading by 25%.  
Caution: Do not hold the steering in its stopped condition for long as the servo will draw excessive current and possibly be damaged.

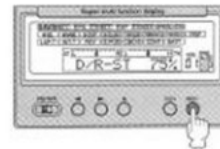
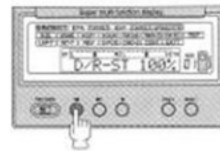

- (5) Adjust the Steering Dual Rate with the Steering Dual Rate Dial. Turning the dial to the right will increase the steering angle; turning the dial to the left will decrease it. Caution: If Steering Dual Rate is not desired, the dial should be kept at its full right position. Setting the Steering Dual Rate at 150% and the Steering EPA at 150% may increase the dead band (lack of sensitivity at center) of the steering servo.



### ST-EPA (STEERING END POINT ADJUSTMENT)

This function is used to correct a model's turning radius if it differs from left to right.

(1) First adjust the Steering Trim, then the EPA.

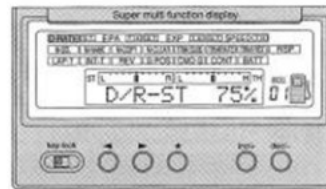

(2) Depress the Function Select Key and move the cursor to ST-EPA.

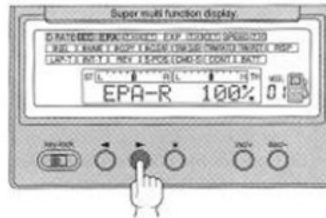

(3) Turn the Steering Wheel clockwise and set the right steering angle with the Inc.+ or Dec.- Key as desired. Then turn the Steering Wheel counter-clockwise and set the left steering angle with the Inc.+ or Dec.- Key.

Note: The recommended standard setting is 100%.

Caution: When setting the Steering EPA, adjust the Steering Trim first.

Set the Steering Trim as follows:

- (1) Reset the trim
- (2) Set the servo neutral.
- (3) Adjust the servo center with the Sub-Trim.

Remember that setting the Dual Rate at 150% and the Steering EPA also at 150% may result in increased servo dead band.

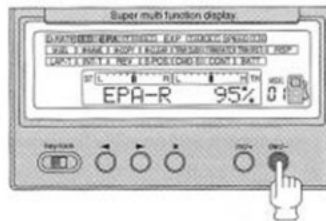

### EPA TH (THROTTLE END POINT ADJUSTMENT)

Throttle EPA will adjust the carburetor throttle arm stroke, the high point of an Electronic Speed Controller (ESC) and the braking.

(1) Depress the Function Select Key and move the cursor to TH-EPA.

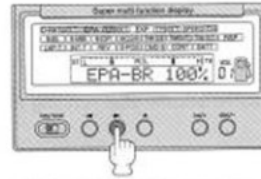

(2) For engine powered cars, to set the high throttle position, pull the Throttle Trigger to its high position and adjust the position of the servo and engine throttle arm with the Inc.+ or Dec.- key.



Note: For electric motor powered cars using an ESC, set the EPA high position to 100% unless a low speed power response is desired in which case a setting of 50 to 70% should be used.

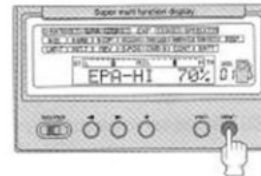

(3) To adjust braking on engine powered cars, push the Throttle Trigger all the way forward and adjust the brake with the Inc.+ or Dec.-Key. To adjust the brake function of the electric motor powered car with an ESC, set the brake to 100% while pushing the throttle trigger to its forward position.



Note: It is possible to set the brake value to 160% maximum. While driving the car, braking action can be adjusted by using the Brake Trim Wheel located on the upper handle. The Brake Trim on the other side of the handle is provided for the left-hand user. Please use the Trim Lock to avoid undesired operation.

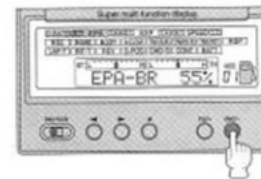

Caution: On an engine powered car or boat, if the throw of the throttle servo is set excessively high, it may cause the servo to stall, draw high current and possibly result in damage to it.



### OPERATION OF THE DIGITAL TRIM

Your SANWA M8 transmitter utilizes a Digital Trim system which eases adjusting the trims while operating your model. Changes as fine as one degree can be made. In addition, it has an Auto-Trim System which memorizes the trim position automatically after running the model.

### STEERING TRIM

The Steering Trim is used to correct any inherent differences in the right and left turns of a model as determined by its mechanical characteristics.

Caution: When adjusting the Steering EPA, first adjust the Steering Trim as follows.

- (1) Reset the trim.
- (2) Set the servo neutral
- (3) Adjust the servo center with the Sub-Trim.

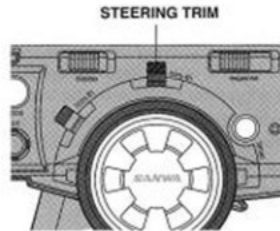

### THROTTLE TRIM

The M8's Center Trim is not affected by the settings of the throttle high or the amount of brake, therefore changing the neutral adjustment will not affect the brake setting.

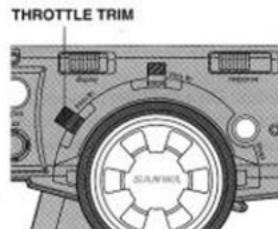

**EXP (EXPONENTIAL)**

This M8 function modifies the servo (or ESC) action in relation to the movement of the steering wheel or the throttle trigger. Adjusting it in the Positive (+) direction will quicken the action from neutral; adjusting it in the Negative (-) direction will lessen it.

Steering Exponential

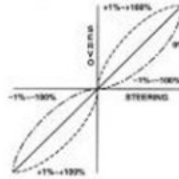

Throttle Exponential

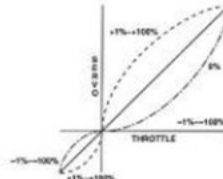

Solid Lines Indicate Linear Operation

**ST EXP (STEERING EXPONENTIAL)**

Three settings, QUICK, LINEAR and MILD will allow you to set the steering response to that most effective for your particular model.

Generally, if your model over-steers, adjust the ST EXP towards the Negative (-) direction. If it under-steers, adjust it towards the Positive (+) DIRECTION.

- (1) Depress the Function Select Key to move the cursor to ST-EXP.

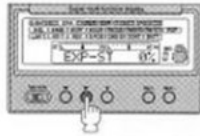

- (2) If the steering response is too fast, depress the DEC.- Key to lessen it.

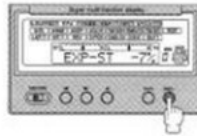

- (3) If the steering response is too mild, depress the INC. + Key to increase it.

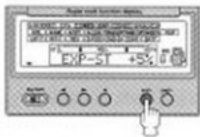

- (4) If you opt not to use the Steering Exponential or can not decide on the proper setting, set it to 0% (Linear).

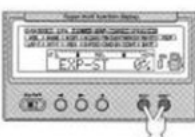



### EXP TH (THROTTLE EXPONENTIAL)

Three settings, QUICK, LINEAR and MILD will allow you to set the throttle response to that most effective for your model. Generally, if an R/C car track is slippery or the model is over responsive to throttle, set the EXP-TH towards the Negative (-) direction. If the track provides high traction or if more torque is desired, set it towards the Positive + direction. The throttle high and brake can be adjusted independently.

(1) Depress the Function Select Key, move the cursor to TH-EXP.

(2) If the power is applied too rapidly, depress the DEC- key and adjust it towards the Negative (-) direction.

(3) If the power response is too mild, depress the INC+ key and adjust it towards the Positive (+) direction.

(4) To re-adjust the brake, depress the Scroll Key to EXP-BR and adjust it with the INC.+ or DEC.- Keys.

(5) If you opt not to use Throttle Exponential or can not decide on the proper setting, set it to 0% (Linear).

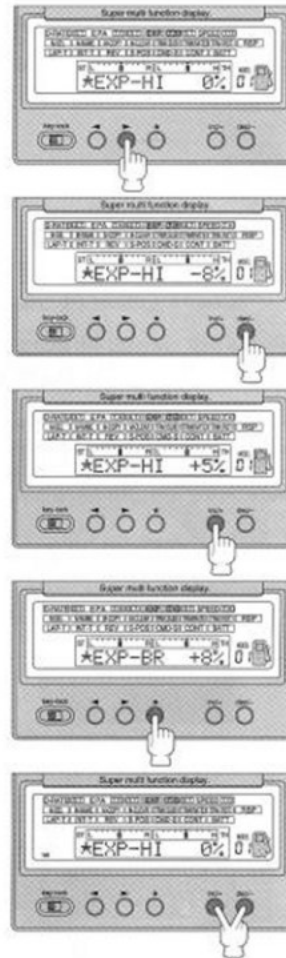

### SPEED (SERVO SPEED)

This function sets the speed at which the servos (or ESC) will respond. This assures you of smoothly controlled turns and precise throttle control.

### ST SPEED (STEERING SERVO SPEED)

This function sets the speed of the servo relative to the steering wheel rotation. It can be set independently for initial servo operation and its return to neutral. However, if the steering servo speed is set lower than the actual speed of the servo, its speed is not affected.

(1) Depress the Function Select Key and move the cursor to ST-SPEED.

(2) To decrease the initial servo speed, depress the scroll key to display ST-FWD and adjust the value with the DEC- Key.

(3) To increase the servo return speed, depress the Scroll Key to display ST-RTN and adjust the value with the DEC- Key.

(4) if you opt not to use the Steering Servo Speed function, or can not decide on the proper setting, set it at 0% (linear).

Note: For R/C car driving, it is important to adjust the servo response for the most effective steering without over steering. The Steering Speed Function, when properly set, will reduce unnecessary steering with smooth cornering.

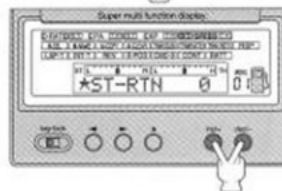
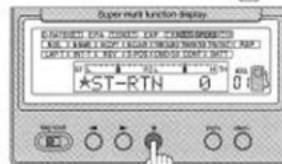
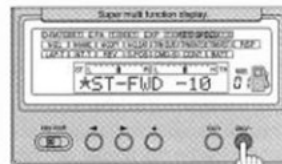
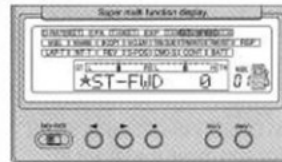

### SPEED TH (THROTTLE SERVO SPEED)

This function sets the throttle servo (or ESC) reaction relative the movement of the throttle trigger. It does not have any effect as the trigger returns to neutral or when the brake is used.

(1) Depress the Function Select Key and move the cursor to TH-SPEED.

(2) To delay the throttle servo speed, depress the DEC.- Key.

(3) If you opt not to use the Throttle Servo Speed or you can not decide on the proper setting, set it at 0% (Linear).

Note: For R/C car driving, it is important to match the throttle reaction to the tire traction. The Throttle Servo Speed will eliminate unnecessary power and provide the proper tire grip for smooth driving.

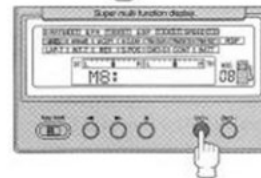
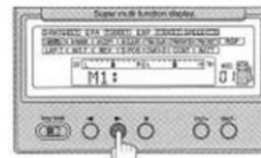
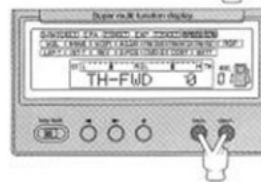
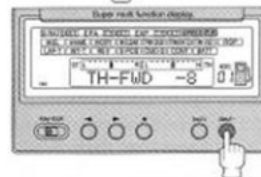
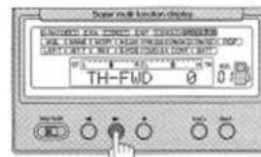

## M-NAME (MODEL NAME)

Each Model Name can include up to eight characters.

(1) Depress the function Select Key and move the cursor to M-NAME.

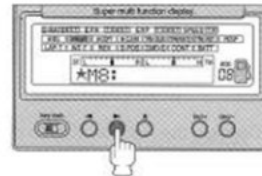

(2) Depress the INC.+ or DEC.- Key to select the characters.

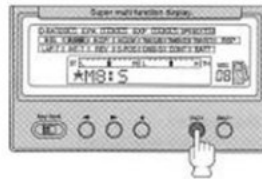

(3) Depress the asterisk (\*) Key to advance to the next character.

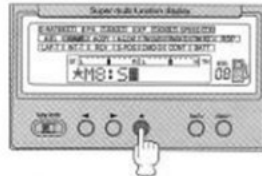

(4) Repeat steps (2) and (3) to complete the model name. Depress the INC.+ and DEC.- Keys simultaneously to display the first character of each group.

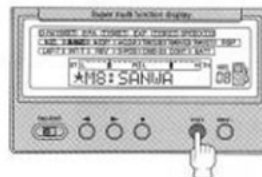

**M-COPY (MODEL COPY)**

It is possible to transfer all data from one model to another.

(1) Depress the Function Select Key and move the cursor to M-COPY.

(2) Depress the Asterisk Key to display the model you wish to copy to.

(3) Depress the INC.+ and DEC.- Keys simultaneously; EXECUTING will appear on the display.

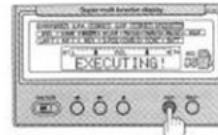
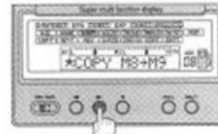
**M-CLEAR (MODEL CLEAR)**

You can clear any model memory that you no longer need.

(1) Depress the Function Select Key and move the cursor to M-CLEAR.

(2) Depress the Asterisk Key to scroll to the model you wish to clear.

(3) Depress the INC.+ and DEC.- Keys simultaneously; EXECUTING will appear on the display.



### TRIM (SUB)

This function will readjust the steering and throttle trim so that the trim levers can remain at their center. When adjusting the linkages, the Trim Center should be set first with the Sub-Trim.

(1) Before adjusting the linkage, set the position of the Trim Lever for the Steering or Throttle Sub-Trim to its center (0%).

(2) Install the servo arm as close as possible to its neutral position.

(3) Depress the Function Select Key and move the cursor to TRM(SUB).

(4) Depress the Asterisk Key to display either SUB-ST or SUB-TH.

(5) Depress either the INC.+ or the DEC.- Key to set the neutral position.

Note: Preset the servo arm to neutral as closely as possible. If the Sub-Trim and the Main Trim are adjusted to their maximum position, some dead band may appear at the Steering Wheel and Throttle Trigger.

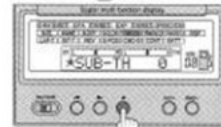
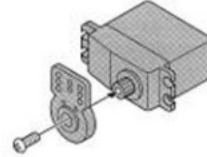
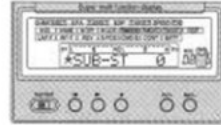

**TRM(RATE) (TRIM RATE)**

This function will adjust the degree of trim available.

(1) Depress the Function Select Key and move the cursor to TRM(RATE).

(2) Depress the DEC.- Key to adjust the Trim Rate.

Note: To reset the Trim Rate to 100%, depress the INC.+ and DEC.- Keys simultaneously.

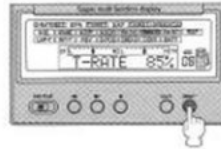
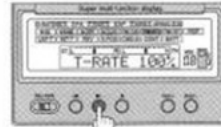
**TRM(RST) (TRIM RESET)**

This functions will set the positions of the Main Trim and Sub Trim into the Trim Memory.

(1) Depress the Function Select Key and move the cursor to TRM(SUB).

(2) Depress the Asterisk Key and select either Steering or Throttle.

(3) Depress the INC.+ or DEC.- Keys to set the data.

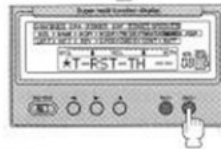
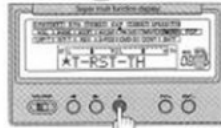
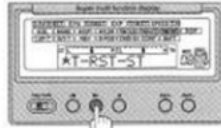

### RSP (RESPONSE SWITCH)

This functions adjusts the Steering or Throttle Response Time. This original and unique feature will result in sharp steering and precise throttle response for optimum model performance.

(1) Depress the Function Select Key and move the cursor to RSP.

(2) Depress the Asterisk Key and select either RSP-ST or RSP-TH.

Response  
Switch



(3) Turn the Response Switch to ON. RSP ON will appear on the display.

(4) To quicken the response, depress the INC.+ Key; it is adjustable from 0 (Linear) to +10 (Very Quick).

(5) For milder response, depress the DEC.- Key; it is adjustable from 0 (Linear) to -10 (Very Mild).

Note: If an adjustment of the Response Time if not desired, set it to 0 by depressing the INC.+ and DEC.- Keys simultaneously.

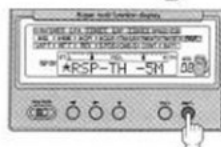
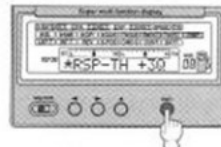
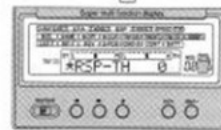
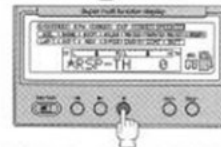
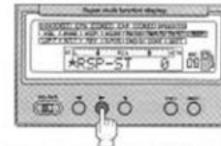



## LAP TIMER

This function will measure, and record each Lap Time up to 99 laps.

(1) Depress the Function Select Key and move the cursor to LAP-T.

(2) Depress the INC.+ or DEC.- Key to turn the Lap Timer ON.

(3) Depressing the Asterisk Key will display the Target Time.

(4) Depress either the INC.= or DEC.- Keys to set the Target Time. It can be set every 10 seconds up to 60 minutes.

(5) To start the time, depress the Timer button located on the right side of the Steering Wheel. The Display will indicate the Lap Timer as being ON or OFF.

(6) Depressing the Timer button again; the Lap Time will be displayed for 3 seconds, then the timer will re-start. The Timer Button is inoperable during the 3 seconds.

(7) An audio alarm will beep 5 seconds before the Target Time is reached. When the Target Time has elapsed, a steady tone will sound.

Note: Depressing the Timer button after the Target Time has elapsed will display the Total Time.

If it is desired to stop the Lap Timer before the Target Time is reached, depress the Time button for 3 seconds, or depress the INC.+ and DEC.- Keys simultaneously.

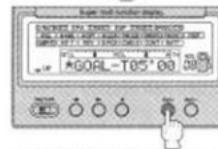
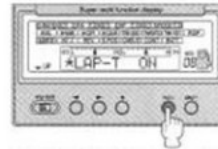
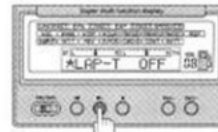

Timer Button

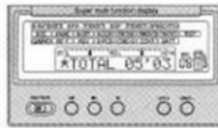

(8) To display the Lap Time after a run, depress the Asterisk Key. Depressing the INC.+ Key will display the first Lap Time relative to the average Lap Time.

(9) To delete the Lap Time from the memory, depress the Scroll Key to show the Total Time and depress the INC.+ and DEC.- Keys simultaneously; LAP-CLR will appear on the display. Depress the INC.+ and DEC.- Keys simultaneously again to delete the Lap Time.

Note: Depressing the DEC.- Key alone when LAP-CLR is displayed will return the display to the Total Time.

\* The Target Time is not deleted. Whenever the Lap Timer is used, it automatically erases all previous lap data.

(10) Upon stopping the Lap Timer, its setting is automatically turned OFF; to use it again, first re-set it to ON.

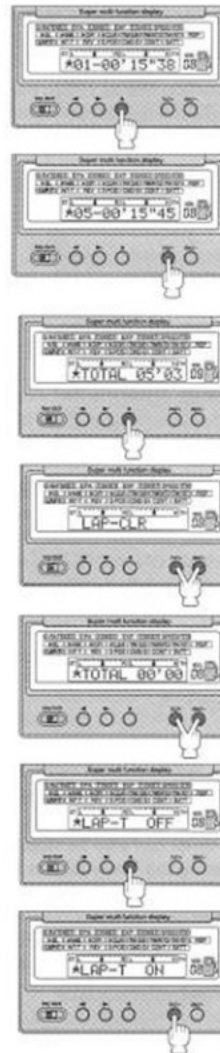

### INT-T (INTERVAL TIME)

This function allows you to measure the Elapsed Time and to see if you are running within your intended Target Time.

- (1) Depress the Function Select Key and move the cursor to INT-T.
- (2) Depress the INC.+ or DEC.- Keys to display INT-T ON.
- (3) Depress the Asterisk Key to display the pre-set time; it can be from 3\*00 to 59\*90.
- (4) Depress either the INC.+ or the DEC.- Key to set the desired Lap Time. It can be set to within 0.1 second.
- (5) The Timer is started by depressing the Timer Button located at the right side of the Steering Wheel; the display will indicate ON or OFF. The alarm will beep when the Target Time entered has elapsed.

\* Depressing the Timer Button after the Timer has started will reset the Timer to start again.

- (6) If it is desired to stop the Elapsed Timer, depress the INC.+ and DEC.- Keys simultaneously. This is effective when the cursor is on INT-T.

\* The Timer can also be stopped by depressing the Timer Button for 3 seconds.

- (7) When the Elapsed Timer is stopped, it is automatically turned OFF. If it is to be used again, it must first be turned ON.

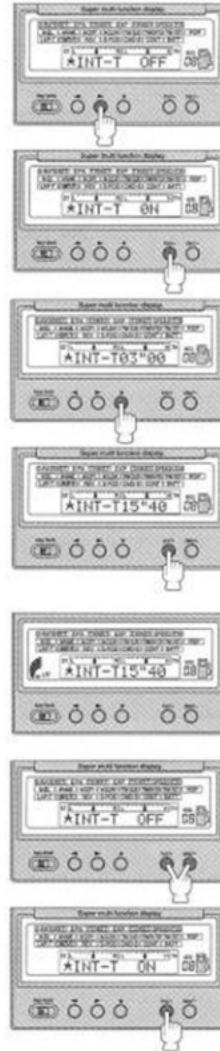

### REV ( SERVO REVERSE)

This functions reverses the direction of the servo movement.

- (1) Depress the Function Select Key and move the cursor to REV.
- (2) Depress the Asterisk Key, select either ST (Steering), TH (Throttle) or AUX (Auxiliary).
- (3) Depress either the INC.+ or the DEC.- Keys to change the direction of the servo.

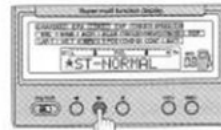

### S-POS (STARTING POSITION)

This functions is exclusively for use in a glow-engine powered R/C car or boat. It does not apply to any electric powered models. It eases starting the engine by setting its idle higher when it is being started.

- (1) Depress the Function Select Key and move the cursor to S-POS.
- (2) Set the Throttle Trim at its neutral center, then depress the Starting Position Switch.
- (3) Depress the INC.+ and set it slightly higher than the normal idling position. If increased by more than 1%, the alarm will sound.

Note: Since it is not used with electric powered models, set the S-POS at 0% when using your M8 with one. The alarm will not sound under this condition even though the S-POS switch is ON.

\* Be sure the Throttle Trim neutral is initially set at its center. If not so, the servo may not move to the intended starting point.

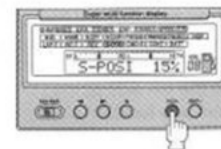
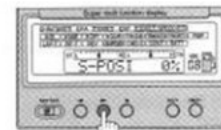

### CMD-S (COMMAND SIGNAL)

This function will change the audio tone heard during the Trim and Function Key operation.  
One of ten different tones can be selected.

(1) Depress the Function Select Key and move the cursor to CMD-S.

(2) Depress the INC.+ or DEC.- Key to select the desired tone. Select OFF to silence it completely.

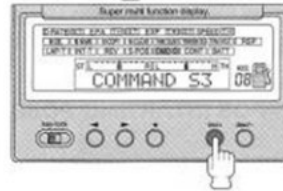
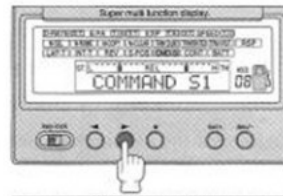

### CONT (LCD CONTRAST)

This function adjusts the brightness of the LCD (Liquid Crystal Display) screen.

(1) Depress the Function Select Key and move the cursor to CONT.

(2) Depress either the INC.+ or the DEC.- Key to adjust the LCD brightness.

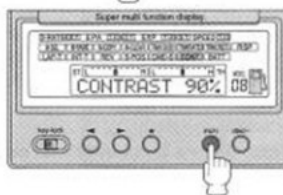
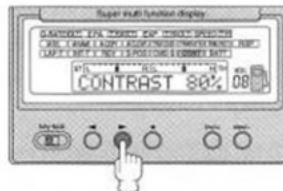

### KEY LOCK

This function protects you from losing any data stored in the M8's memory through accidental manipulation of the keys.

Turning on the Key Lock Switch located on the left side of the LCD screen will prevent any function changes by depressing any of the keys.

Key Lock



### DSC (DIRECT SERVO CONTROLLER)

The M8's Direct Servo Controller serves to allow adjustment of the linkages on your model and all settings on the transmitter without emitting a signal and causing interference to others on the same frequency channel. To use the DSC on glow engine powered models, use the DSC equipped Switch Harness.

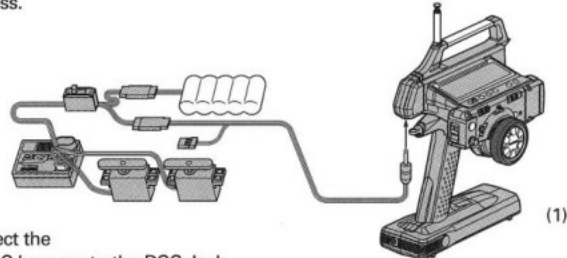

- Connect the DSC harness to the DSC Jack on the side of the transmitter. A DSC indication will appear on the display.
- (2) Connect the other end of the DSC harness to the charging connector on the Switch Harness.
  - (3) To use the DSC Function, turn ON the receiver Switch Harness.

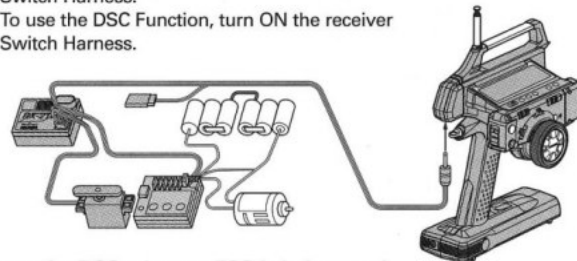

#### To use the DSC when an ESC is being used.

- (1) Connect the DSC harness to the DSC jack on the side of the transmitter. A DSC indication will appear on the display.
- (2) Connect the other end of the DSC harness to the battery connector on the receiver.
- (3) To use the DSC Function, turn ON the ESC power switch.

#### Note:

It is not necessary to turn ON the transmitter when using the DSC. Batteries must be installed in the transmitter for DSC operation. Batteries must be installed in the battery powered model for DSC operation. Be sure to disconnect the DSC cord after using the DSC.

## POSITION OF RECEIVER CONNECTORS

Receiver	Position
1.	Steering
2.	Throttle
3.	Auxiliary
4.	Battery or DSC Harness

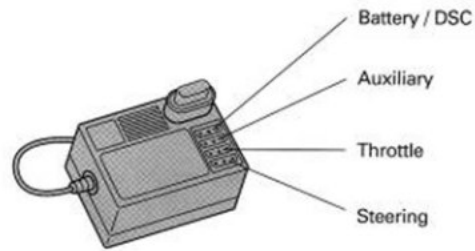

**SANWA CORPORATION**

CHIYODA DAIICHI BLDG.,  
2-4-17 TENJINBASHI  
KITA-KU OSAKA

PHONE :06)358-2331  
FACSIMILE:06)358-2355

670A11873A