

*This equipment has been tested in accordance with the requirements contained in the appropriate Commission regulations. To the best of our knowledge, these tests were performed using measurement procedures consistent with industry or Commission standards and demonstrate that the equipment complies with the appropriate standards. Each unit manufactured, imported or marketed, as defined in the Commission's regulations, will conform to the sample(s) tested within the variations that can be expected due to quality production and testing on a statistical basis.*

*We further certify that the necessary measurements were made by Kansai Electronic Industry Development Center, Ikoma Emission Measurement Station, 10830, Takayama-Cho, Ikoma-City, Nara, 630-01 Japan.*

## TABLE OF CONTENTS

**Page #**

|    |   |
|----|---|
| 2  | Table of Contents                                       |
| 3  | Radio Control System and Specifications                 |
| 4  | Academy of Model Aeronautics / Initial Preparation      |
| 5  | Transmitter Features                                    |
| 6  | Airborne System Connections / NiCd Charging Information |
| 7  | Airborne Components / Warning Alarms                    |
| 8  | Transmitter Battery Removal / Stick Length Adjustment   |
| 9  | Transmitter Stick Tension Adjustment                    |
| 10 | Trainer System  |
| 11 | Microprocessor / Bar Graph Voltage Indicator            |
| 12 | Features Descriptions                                   |
| 13 | Stick and Switch Functions                              |
| 14 | Dual Rates / Exponential                                |
| 15 | End Point Adjustment / Servo Centering                  |
| 16 | Servo Reversing / V-Tail Mixing                         |
| 17 | Delta Wing / Flaperons                                  |
| 18 | Flaperons CONTINUED / Differential                      |
| 19 | Flap to Elevator Mixing / Aileron to Rudder Mixing      |
| 20 | Model Select / Elevator to Flap Mixing                  |
| 21 | Throttle Cut / Count Down Timer                         |
| 22 | Sound Click / Battery Voltage Display                   |
| 23 | Model Settings  |

## **RADIO CONTROL SYSTEM**

*Thank you for selecting the Airtronics VG6000 Radio System. In designing the VG6000 we have made every effort to provide you with a radio that will allow you to extract the maximum performance from your powered aircraft, or sailplane, while at the same time simplifying the task of setting up and adjusting your model. These instructions are written in great detail to help you understand what all of your VG6000 capabilities are. Flyers may find it advantageous to read all sections of the manual to become more acquainted with the operation of the VG6000 system.*

*Again, we appreciate your selection of an Airtronics Radio Control System and wish you many hours of flying enjoyment.*

### **VG6000 Transmitter Specifications:**

|                    |  |
|--------------------|--|
| Transmitter Type:  | 6 Channel, Dual Stick with propriety Microprocessor. |
| Dimensions:        | W: 7.5" X H: 8.0" X D: 2.5"                          |
| Weight:            | 1 lb. 11 oz  |
| Power Output:      | 600 mWatts   |
| Frequencies:       | 72 MHz   |
| Modulation:        | PPM/FM Only  |
| Power Supply:      | 9.6 Volt, 700 mAh NiCd                               |
| Current Drain:     | 180 MA   |
| Temperature Range: | 0 to 160 degrees F                                   |
| Pulse Width:       | 1.5 ms (nominal)                                     |
| Model Memory:      | 4  |

### **VG6000 Receiver Specifications:**

|                        |  |
|------------------------|--|
| Receiver Type:         | 92777Z PPM/FM 7 Channel, Super Narrow Band with Universal "Z" Connectors |
| Receiver Sensitivity:  | 1.5 microvolts   |
| Dimensions:            | L: 2.20", W: 0.06", H: 0.82"   |
| Weight:                | 1.2 ounces   |
| Receiver Power Supply: | Four Cell, 4.8 Volt, 700 mAh NiCd  |

Additional Receivers that will work with the VG6000:

92515Z 5 channel FM Single Conversion receiver. (channels 11 thru 54 only)

Many older FM Airtronics receivers will work with the VG6000, check or call us to find out more.

# VG6000

**ACADEMY OF MODEL AERONAUTICS  
5161 East Memorial Drive  
Muncie, Indiana 47302**

The Academy of Model Aeronautics (AMA) is a national organization representing modelers in the United States. We urge you to examine the benefits of membership, including liability protection in the event of certain injuries. The Academy has adopted simple and sane rules which are especially pertinent for radio controlled flight as the OFFICIAL AMA NATIONAL MODEL AIRCRAFT SAFETY CODE, which we have partially reprinted below:

I will not fly my model aircraft in sanctioned events, airshows or model flying demonstrations until it has been proven to be airworthy by having been previously, successfully flight tested.

I will not fly my model higher than approximately 400 feet within 3 miles of an airport without notifying the airport operator. I will give the right-of-way and avoid flying in the proximity of full-scale aircraft. Where necessary, an observer shall be utilized to supervise flying to avoid having models fly in the proximity of full-scale aircraft.

Where established, I will abide by the safety rules for the flying site I use, and I will not willfully and deliberately fly my models in a careless, reckless and/or dangerous manner.

I will have completed a successful radio equipment ground range check before the first flight of a new or repaired model.

I will not fly my model aircraft in the presence of spectators until I become a qualified flyer, unless assisted by and experienced helper.

I will perform my initial turn after take off away from the pit or spectator areas, unless beyond my control.

I will operate my model using only radio control frequencies currently allowed by the Federal Communications Commission. (See chart below) Only properly licensed amateurs are authorized to operate equipment on amateur band frequencies.

## **72 MHz BAND by Channel and Channel Frequency**

|           |           |           |           |           |
|-----------|-----------|-----------|-----------|-----------|
| 11 72.010 | 21 72.210 | 31 72.410 | 41 72.610 | 51 72.810 |
| 12 72.030 | 22 72.230 | 32 72.430 | 42 72.630 | 52 72.830 |
| 13 72.050 | 23 72.250 | 33 72.450 | 43 72.650 | 53 72.850 |
| 14 72.070 | 24 72.270 | 34 72.470 | 44 72.670 | 54 72.870 |
| 15 72.090 | 25 72.290 | 35 72.490 | 45 72.690 | 55 72.890 |
| 16 72.110 | 26 72.310 | 36 72.510 | 46 72.710 | 56 72.910 |
| 17 72.130 | 27 72.330 | 37 72.530 | 47 72.730 | 57 72.930 |
| 18 72.150 | 28 72.350 | 38 72.550 | 48 72.750 | 58 72.950 |
| 19 72.170 | 29 72.370 | 39 72.570 | 49 72.770 | 59 72.970 |
| 20 72.190 | 30 72.390 | 40 72.590 | 50 72.790 | 60 72.990 |

## **INITIAL PREPARATION**

### **PACKAGING:**

The packaging of your Airtronics VG6000 Radio Control System has been especially designed for the safe transportation and storage of the radio's components. After unpacking your radio, DO NOT DISCARD THE CONTAINERS! You should set the packaging aside for use if you ever need to send your radio in for service, or to store your radio in case you do not plan to use it for an extended period of time.

## **VG6000 TRANSMITTERS FEATURES**

The VG6000 narrow band PPM/FM computer radio control system is designed for the use of power models and sailplanes for pilots who demand a quality product. The VG6000 is packed with all of the capabilities that the beginner as well as the more advanced modelers demand. It has the features available to get the most out of any type of model.

### ***Program Features***

- Elevator and Aileron Dual Rates
- Elevator and Aileron Exponential
- End Point Adjustment all Channels
- Servo Centering all Channels
- Servo Reversing all Channels
- 4 Model Memory
- Timer
- Sound Click On/Off
- Battery Voltage Display
- Throttle Cut
- Training System Compatible

### ***Mixing Capabilities***

- V-Tail
- Delta Wing
- Flapewron
- Aileron Differensial
- Flap to Elevator Mixing
- Aileron to Rudder Mixing
- Elevator to Flap Mixing

### ***Transmitter Features***

- Large LCD Display
- One Menu Format Display
- Digital Trim Display
- Battery Voltage Bar Graph Display
- Digital Trims
- Low Battery Alarm
- Throttle Cut Button
- Trainer Button
- Dual Rate Slide Switches
- 3 Position Flap Switch
- 2 Position Retract Switch
- Smooth Movement Sticks
- Oragomic Curved Case
- Neck Strap Holder

# VG6000

## AIRBORNE SYSTEM CONNECTIONS

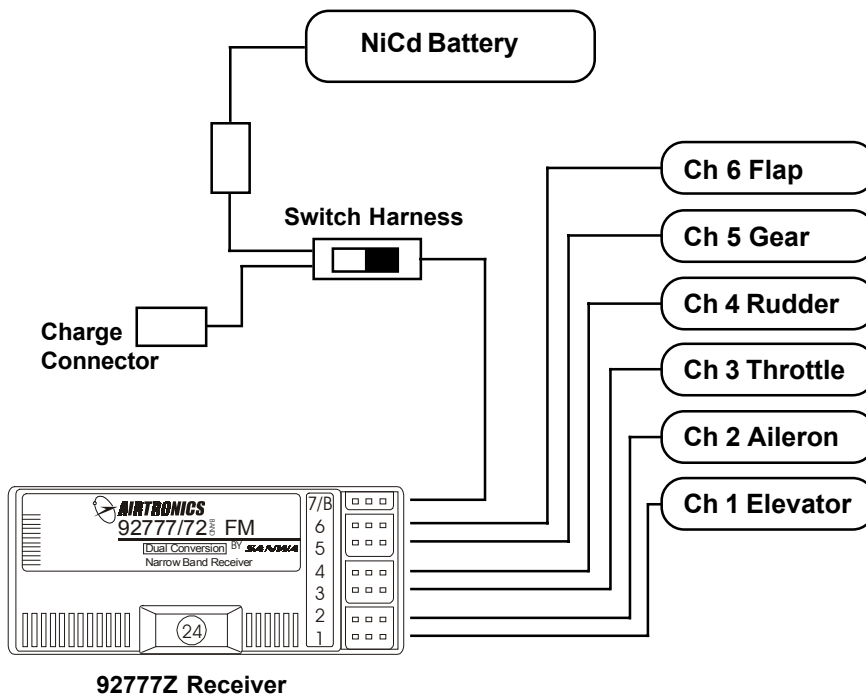

The above diagram shows how to connect the components of your VG6000 system together. At this point your objective is to get the system operating on your workbench. Once connected you must then refer to the corresponding diagram for your system showing the transmitter control stick function.

### **NiCd BATTERY CHARGING INFORMATION:**

In order to protect the charging circuit in your VG6000 transmitter, a diode has been installed to protect it from some of the high discharge rate "cyclers" on the market. We recommend that you charge the transmitter battery (while installed) with the supplied ATX charger, Part # 95033Z.

Should you wish to "cycle" or discharge the transmitter battery, you must first remove it from the transmitter. This allows you to bypass the protective diode.

The following two Airtronics service items will allow you to "cycle" your VG6000 transmitter battery. See your local dealer for these items.

(1) #99704 Transmitter Charging Plug with Cable for use with your cycling device (black wire w/white tracer is positive).

(1) #97051 Transmitter Battery Cycling Adapter Cable.

Above items will also work with Airtronics Quasar, Radiant, Vanguard, VG Series and all RD Series transmitter batteries.

## **AIRBORNE COMPONENTS**

While your systems batteries are charging, you can familiarize yourself with the airborne portion of your radio. The airborne portion of the radio refers to any components which are mounted in your airplane and carried aloft when you fly. The airborne components consist of the receiver, which receives the signals from the transmitter, decodes them, and relays the commands to the servos. The servos which are simply electronically controlled motors used to move the controls of the plane. The NiCd battery pack which provides power for the receiver and servos to operate and the switch harness which allows you to turn the airborne package on and off.

## **CONNECTORS**

Your VG6000 unit is equipped the new universal AIRTRONICS "Z" connectors which are color coded blue, and are electrically compatible with the receivers of other radio control system manufacturers. The connectors are rugged but should be handled with care. Note that these connectors are not compatible with older AIRTRONICS R/C equipment unless Adapter p/n 99399Z is used!

## **"Z" CONNECTOR**

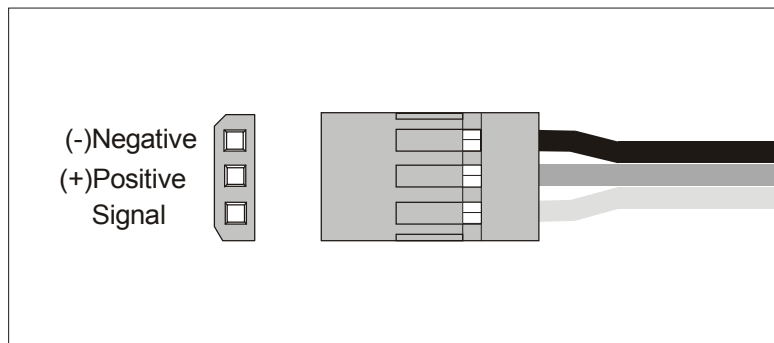

## **AUDIO LOW VOLTAGE ALARM**

Your VG6000 transmitter is equipped with an Audio Alarm which will sound whenever the transmitter batteries drop below 9.5 volts during transmitter operation. If the alarm sounds while you are flying, land immediately and don't operate the transmitter until it has been charged for 12 hours. The transmitter should normally operate 120 to 150 minutes before the alarm sounds. If the alarm sounds even after the batteries have been on charge for the required time it indicates that there is a problem with either the battery pack or the transmitter, and you should contact AIRTRONICS about service.

## **THROTTLE HIGH WARNING**

The VG6000 has a built in warning feature that will not allow you to use the transmitter if the throttle stick is not in the lowest position when you turn on the transmitter. If the throttle stick is not in the low position, when you turn it on, you will hear a continuous beeping sound and the display will read ( HI ). Pull the throttle stick down to the full low position. The normal menu will then be displayed and you can operate and/or program the transmitter.

# VG6000

## TRANSMITTER BATTERY REMOVAL

The NiCd battery in your VG6000 transmitter can easily be removed and replaced with a fully charged pack to extend operating time.

Additional packs are sold separately as an accessory item under the Airtronics part number 95010 (600Mah) or 95052 (1100Mah) battery packs.

To remove the pack, push down on the two ears of the battery door located on the rear of the transmitter. The door can then be removed and the NiCd battery pack can now be removed and unplugged. Reverse the procedure to install a new pack.

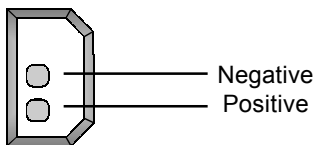

### CAUTION:

Observe the correct polarity when plugging in the NiCd battery pack. If incorrect, damage to the transmitter will occur!

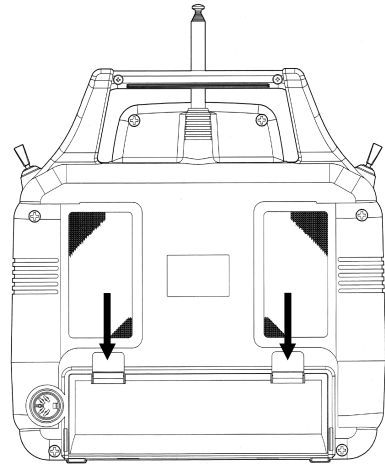

## CONTROL STICK LENGTH ADJUSTMENT

The sticks in your VG6000 transmitter are adjustable in length and spring tension to allow you to tailor their feel to your personal preference. To adjust stick length, hold Part B with your fingers and unscrew Part A counterclockwise to loosen the two pieces. Now screw Part A in or out to the desired position and lock it in place by screwing Part B against it. It is best to leave at least four threads inside Part A when screwed out to its longest length for the best mechanical security. Do not over tighten when you screw the two parts together.

Part (A) Loosen End Cap First

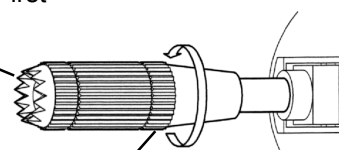

Part (B) Adjust Stick Length by turning here



## TRANSMITTER STICK TENSION ADJUSTMENT

To adjust the spring tension of the transmitter sticks you need to remove the back of the transmitter case. First remove the antenna and the NiCd battery pack from the transmitter. Now remove the eight screws that hold the case back in place, four in the main case, two in the LCD back cover and two on the handle. Once the screws are removed swing the back of the case away from the transmitter being careful of the trainer plug wiring.

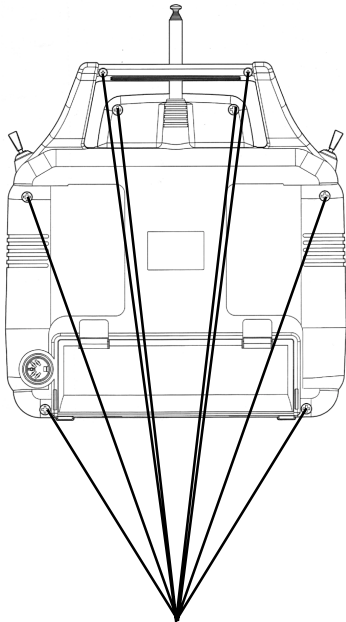

Screw Locations

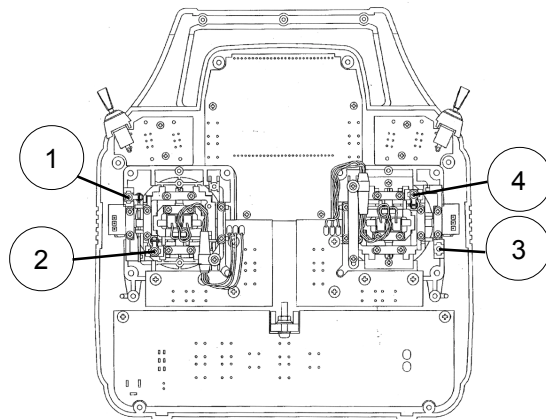

There are four locations for the stick tension adjustment screws installed because the stick controlling the throttle is ratcheted and has no tension adjustment. The #1 and #3 screws adjust the tension for the vertical motion of each stick. The #2 and #4 screws adjust the tension for the horizontal motion of each stick. To make the tension adjustment use a small phillips type screwdriver to turn the adjustment screws. Turning the screw clockwise will increase the stick tension, turning it counterclockwise will decrease the tension. Once you have completed your stick adjustments, replace the case back and install the NiCd battery pack and antenna. Be careful to line the battery charging port pins when replacing the back cover.

### WARNING:

Any other modifications made to the transmitter other than adjusting stick tension will void any and all warranties covered by Airtronics Inc.

# VG6000

## TRAINER SYSTEM

The Trainer system in the VG6000 transmitter allows you to connect any two Airtronics RD series transmitters together for the purpose of training a new pilot. You can also connect the VG6000 to either VG 400, VG 600, Radiant or Vanguard PPM unit. The Trainer cord to use is the ATX Part # 97100.

**The VG6000 is NOT compatible with Infinity 660 or Quasar units.**

In actual use, one of the two transmitters will serve as the Master and the second transmitter will serve as the Trainer. The Master transmitter is held by the instructing pilot, AND IS THE TRANSMITTER THAT MUST MATCH THE RECEIVER FREQUENCY INSTALLED IN THE MODEL! The trainer transmitter is held by the learning pilot, and does not need to be on the same frequency as the model. The frequency of the Trainer transmitter is unimportant because the switch of the trainer transmitter is NOT turned on during instructional flying. Normally during training, the instructor takes the model off and flies it to a reasonable altitude. While the Master/Trainer switch on the Instructors transmitter is left in its OFF position, the Master transmitter will have full control of the model. When the instructor is ready to begin training, he presses and holds the spring loaded switch on his transmitter which transfers control to the student.

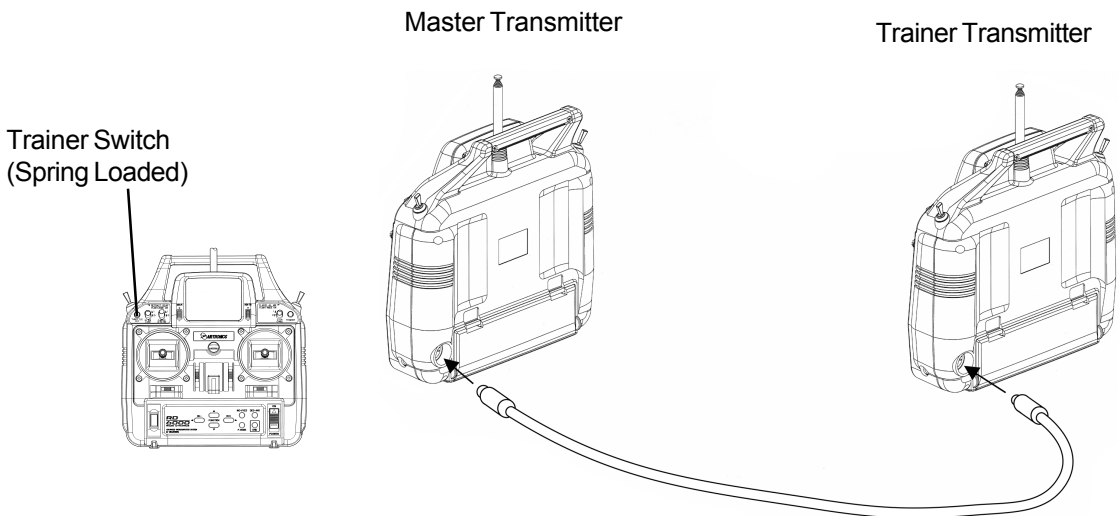

(As long as the instructor holds his Trainer switch in the ON position, the model will respond to the commands of the Trainer transmitter sticks allowing the student to fly the model. It is not necessary for the student to hold the trainer switch on the Trainer transmitter.)

When the instructor ceases to stop training, or if he feels that the student is in a situation that endangers the model, the instructor can release the spring loaded switch and control of the model will immediately return to the Master transmitter. To use the Trainer system, you must plug the appropriate Trainer cable into the back of both the Master and the Trainer transmitters. Turn on the Master transmitter and the Model. The cable will energize the encoder section of the Trainer transmitter. Once you have verified that both the Master and the Trainer transmitters will control the model with the spring loaded switch in the appropriate position you are ready to start training.

### NOTE:

Both transmitters must be programmed identically for the trainer system to function properly. All servos must operate in the same direction, centering, end points, and other settings such as type of Modulation must be identical.

# VG6000

## USING THE VG6000 MICROPROCESSOR

Airtronics has invested a large amount of design effort to ensure that the powerful capabilities of the VG6000 are as simple as possible to use. This manual has been written to offer the user complete instructions for fixed wing aircraft models. You only need to read the introduction section and the one that applies to your type of model. In most cases all of the programming of a setup is accomplished through the use of the input keys on the VG6000 transmitter. The function(s) of these are shown below.

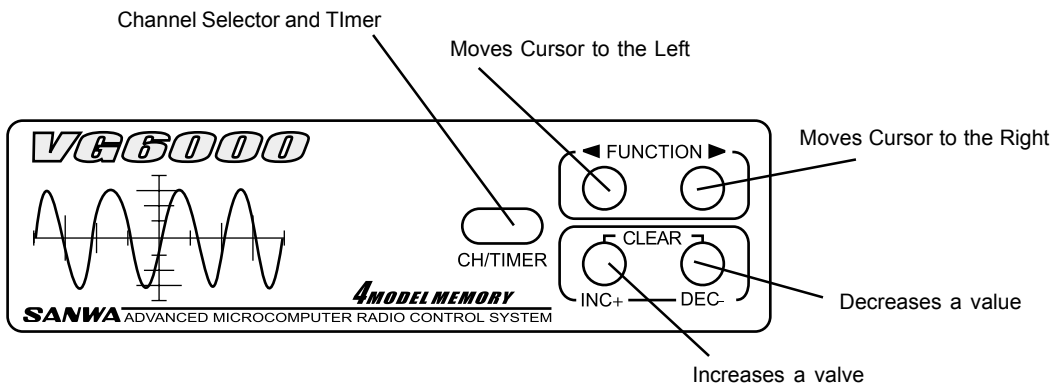

Note: Pressing the INC+ and DEC- keys simultaneously will clear a setting and return it to the default value.

## BAR GRAPH VOLTAGE INDICATOR

As a convenience the VG6000 transmitter provides a Bar Graph transmitter battery voltage indicator at the right of the Liquid Crystal Display screen labeled "Empty" and "Full". You can consider it similar to a visible gas gauge. The Bar Graph indicator is in addition to the normal battery voltage that is displayed on the screen when ever you select BATT. When the Bar Graph reads less than half you should not fly until you recharge the transmitter.

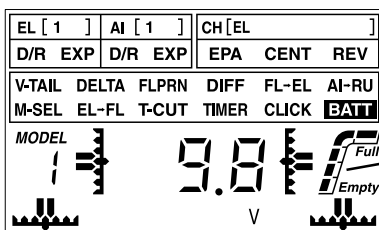

Transmitter Battery Fuel Gauge

# VG6000

## FEATURES DESCRIPTIONS

### Screen Display

|        |                            |
|--------|----------------------------|
| EL     | Elevator Channel           |
| AL     | Aileron Channel            |
| CH     | Servo Channel 1~6          |
| D/R    | Dual Rate                  |
| EXP    | Exponential                |
| EPA    | End Point Adjustment       |
| CENT   | Servo Centering            |
| REV    | Servo Reversing            |
| V-TAIL | Rudder and Elevator Mixing |
| DELTA  | Elevons                    |
| FLPRN  | Flaperons                  |
| DIFF   | Aileron Differential       |
| FL-EL  | Flap to Elevator Mixing    |
| AL-RU  | Aileron to Rudder Mixing   |
| M-SEL  | Model Select 1~4           |
| EL-FL  | Elevator to Flap Mixing    |
| T-CUT  | Throttle Cut               |
| TIMER  | Count Down Timer           |
| CLICK  | Click sound on or off      |
| BATT   | Battery Voltage            |
| MODEL  | Current Selected Model     |

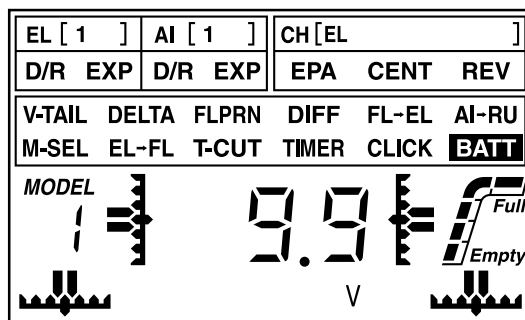

# VG6000

## STICK AND SWITCH FUNCTIONS

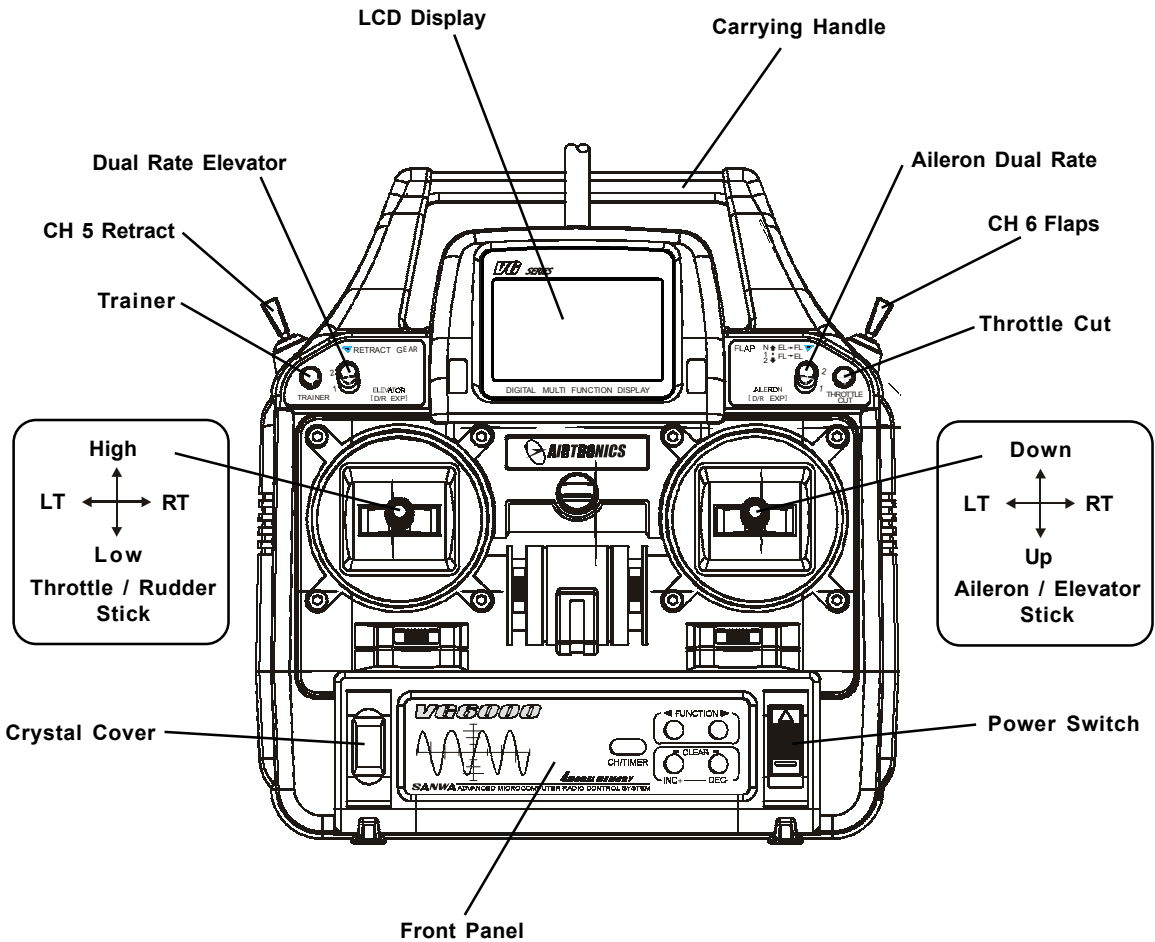

# VG6000

## DUAL RATE AILERON AND ELEVATOR (D/R)

This feature allows you to set a minimum and maximum control rate for ailerons and elevator with the use of a dual rate switch. Move the cursor to high-light the EL D/R. By moving the Dual Rate Elevator switch you can see the 1 and 2 turn off and on in conjunction with the switch location 1 or 2.

Depending on how you like to use your dual rates will depend on the switch direction you want the fast rate to be. For example you would like to take off and fly on a lower rate with the switch in the #1 position and for landing you want a faster rate on position #2.

First set the elevator dual rate switch to the #1 position. You can see on the screen that the percentage is 100. Use the DEC- key to lower the number to about 75%. This will give you 25% less movement than the faster rate on position #2 making position #1 your low rate and #2 your fast rate for landing. Repeat the same for Dual Rate Ailerons by moving the cursor to the AL D/R.

Use the ( INC+ ) or the ( DEC- ) to raise or lower the percentages from 0 to 150%.

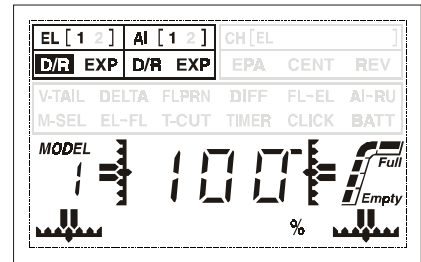

## EXPONENTIAL ELEVATOR AND AILERON (EXP)

Exponential allows you to change the amount of movement the servo has compared to the stick movement. For example, when you move the aileron stick left or right the servo will move at the same rate as the stick when expo is set at 0. When flying your aircraft with 0 expo, you will have the feeling of 1 to 1 or a linear feel. By increasing the expo to about 40% you will change the amount of servo movement compared to the amount of stick movement. When adding expo you will see that the servo will move slower or less amount in the middle to 40% of your stick movement. This will soften the feel of your ailerons around the middle area of the stick but will still give you full servo movement at the end of the stick. Use the FUNCTION keys to move the cursor the EL EXP or AL EXP and press the INC+ key to add expo.

A good starting point for aileron expo is +25% and use +5% for elevator.

Expo can be set for both switch positions 1 and 2.

NOTE: using Negative expo will make your ailerons and elevator more sensitive in the middle stick area which will make the aircraft reactions very fast. Adjustment is from +100 to -100.

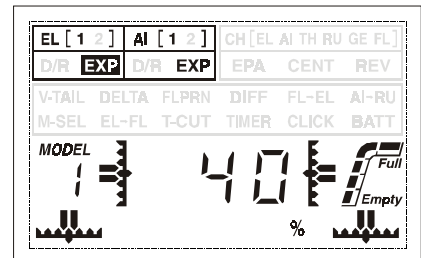

## END POINT ADJUSTMENT ( EPA )

EPA will allow you to increase or decrease the total amount of travel the servo has. EPA is available on all channels and should only be used to fine tune maximum servo movement. All of your linkages and control surfaces should be as close as possible to the model specifications before decreasing or increasing EPA. A good example for EPA would be when you want to use 2 aileron servos on 2 different channels and you want to setup both to have the same amount of throws to each other up and down. NOTE: You must have the FLAPERON feature activated in order to use 2 sperate aileron servos.

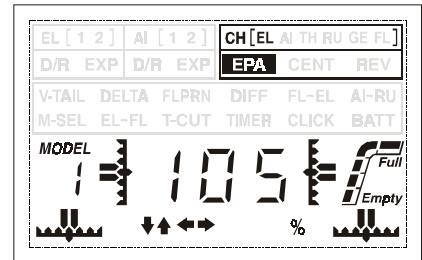

To use EPA, move the cursor to the EPA using the FUNCTION keys. Next use the CH/TIMER key to change to the channel you want to set your EPA. Next move the stick in the direction you want to increase or decrease and take note the arrows on the LCD screen. They will point in the direction you are adjusting. EPA can be set independently from side to side or up and down. Adjustment is from 0 to 150% in each direction.

## SERVO CENTERING ( CENT )

Servo centering to a great feature when it comes to setting up a new model and or setting your servo arms to right at 90 degrees. When using servo centering, take note that it will change not only the center position of the servo but as well change both left and right end points.

Example, you installed a servo arm on your servo but it will not lineup perfectly 90% to the servo. You now can adjust the servo centering so now the arm is at 90% of the servo. Servo centering can be adjusted from 0 to 100% but is best kept within + or - 10% any more than that you will need to try another servo arm or adjust your linkage better.

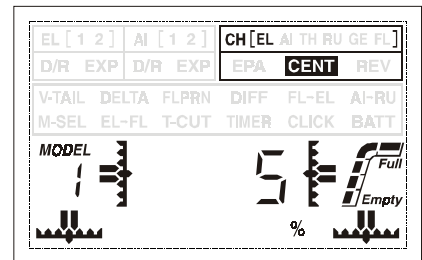

To use CENT, move the cursor to the CENT using the FUNCTION keys. Next use the CH/TIMER key to change to the channel you want to set your CENT. Adjust using the INC+ or DEC- keys. Adjustment is from +100 to -100.

# VG6000

## SERVO REVERSING (REV)

After setting up your aircraft you find that the control surface is moving in the wrong direction, you can use the REV to reverse the direction that the servo operates. REV is available on all channels.

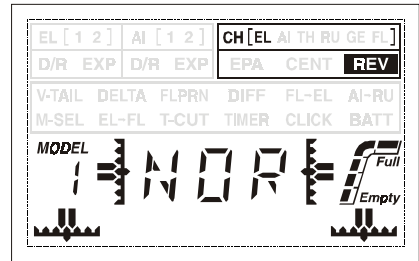

To use REV, move the cursor to the REV using the FUNCTION keys. Next use the CH/TIMER key to change to the channel you want to change the REV. Next press either the INC+ or DEC- to change from NOR to REV.

## V-TAIL MIXING (V-TAIL)

If you have a V-tail aircraft, you will need to activate this feature. After activating V-Tail you will need to first connect the left V-tail to channel 1 and the right V-Tail to channel 4. Next check the directions on both servos making sure they operate in the correct directions. If either one does not work in the correct direction you will need to use REV for that channel. See REV for more details.

You can use both channel 1 and 4 (CENT, EPA and REV) to correctly setup your V-Tail.

To use V-Tail, move the cursor to the V-Tail using the FUNCTION keys. Next use the INC+ or DEC- keys to change from V-Tail OFF to ON.

*NOTE: use channel 1 for the left V-Tail and channel 4 for the right V-Tail.*

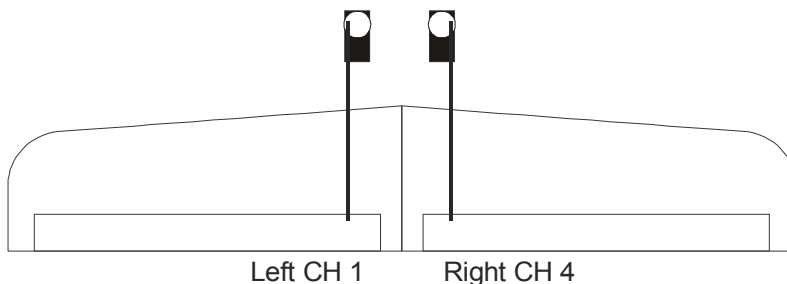
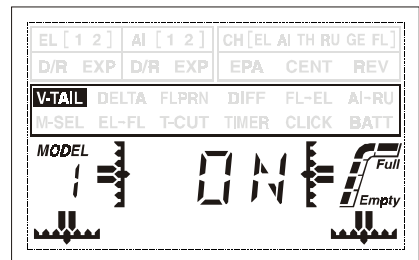



## DELTA WING ( DELTA )

The Delta feature is used when your aircraft is a flying wing. You will use two servos on two separate channels to mix both ailerons and elevator together using only the left and right wing controls. You will use channel 1 for the left wing and channel 2 for the right wing. Mount the servos as shown in the drawing below. After you have installed the servos check to make sure that the ailerons work in the proper direction and check that when you move the elevator, both ailerons move up and down in the proper direction. If either channel is not working in the correct direction simply change the direction of the servo using the REV for that channel.

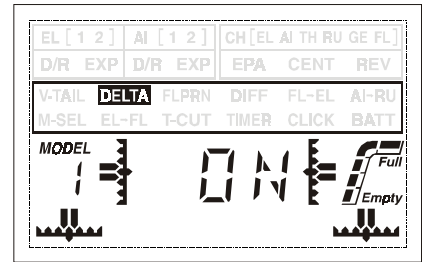

To use DELTA, move the cursor to the DELTA using the FUNCTION keys. Next use the INC+ or DEC- keys to select YES or NO. Selecting YES will activate DELTA on.

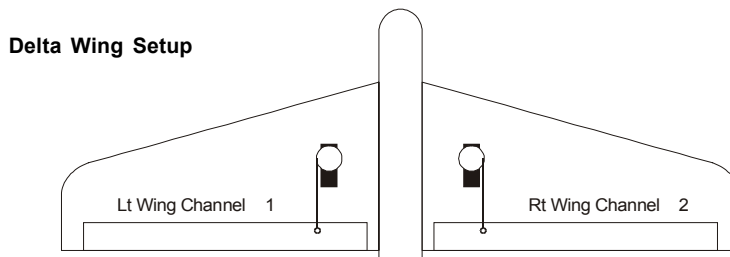

## FLAPERONS ( FLPRN )

Flaperons are used when you want to have both your ailerons work as flaps as well. For this to work you will need to setup two aileron servos on two separate channels on a conventional aircraft. You will be using Channel 2 for the left aileron and channel 6 for the right aileron. Before installing the linkage to the servos make sure that your flap switch CH 6, is in the proper "N" position. This will make sure that when you turn on or activate the flaperons, your servos will not change their centering. Remember! if you activate or turn on Flaperons, both servos should not move. If they do, you do not have the flap switch in the proper position. Next make sure both ailerons are working in the proper direction. If not use the REV to correct. After your ailerons are working properly, move the flap switch "CH 6" to the middle or position 1. Both ailerons should move down to their 50% flaps down position. Next move the flap switch to position 2. This will move both ailerons down to their 100% down position. Remember both flap positions are adjustable.

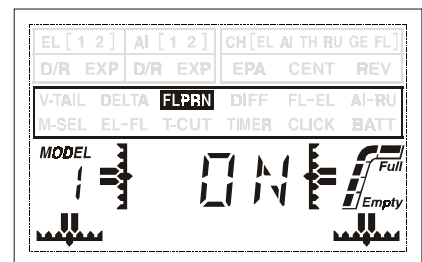

To use FLPRN, move the cursor to the FLPRN using the FUNCTION keys. Next use the INC+ or DEC- keys to change to turn flaperons on or off. See next page for servo setup.

Other features that work together with flaperons: (DIFF), (FL-EL), (EL-FL), (Flaps ch 6)

# VG6000

## FLAPERONS ( FLPRN ) CONTINUED

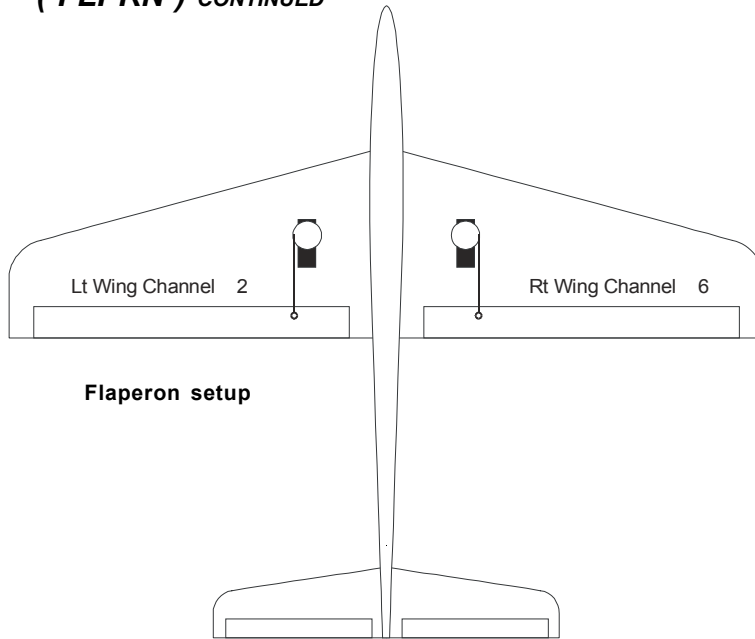

## DIFFERENTIAL ( DIFF )

By turning on your flaperon feature you can now use differential. What differential does is actually change the amount of aileron movement percentage between the aileron being in the up position compared to the down position.

Example: If you had a Piper Cub for an aircraft, you would know that it really does not roll very well. With the use of some differential however, you can make the Cub roll much better. To do this you will need to have your ailerons actually have more up movement than down movement killing more lift than creating lift because a Piper Cub generates a lot of lift with its wing design. This feature is a must for any sailplane flier.

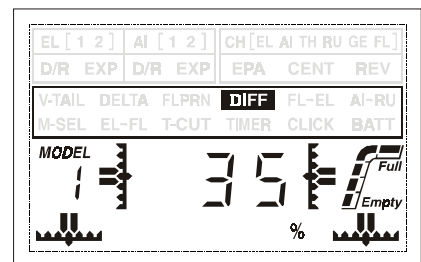

To use DIFF, move the cursor to the DIFF using the FUNCTION keys. Next use the INC+ or DEC- keys to change the percentages from 0 to + or - 100%. Depending on your aircraft typically you will want the ailerons to have more up movement than down when operating your ailerons. This works well for aircraft that has a flat or semi symmetrical air foil.

Other features that work together with differential: (FLPRN), (FL-EL), (EL-FL), (Flaps ch 6)  
DIFF will not work with Delta and will only work if FLAPRN is activated.

## **FLAP TO ELEVATOR MIXING ( FL-EL )**

When you lower your flaps on just about any aircraft, it will tend to raise the nose or start to climb. By using the Flap to Elevator mix, you can change the way the aircraft reacts when the flaps are lowered by adding a small amount of down elevator. Flaps are mainly used to create more lift so the aircraft can land at a slower speed.

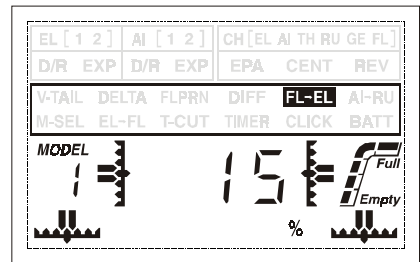

To use FL-EL, move the cursor to the FL-EL using the FUNCTION keys. Next use the INC+ or DEC- keys to change the percentage of up or down elevator as needed. To see the amount of elevator movement you must move the flap switch to position 1 or 2. When the flap switch is in the "N" normal position, you will not see any flap to elevator mixing. Default is set at 0. Range is from -100 to 100% and 0 is no elevator mix at all.

## **AILERON TO RUDDER MIXING ( AL-RU )**

On some high wing aircraft that have a lot of side area on the fuselage will find that aileron to rudder mixing will greatly help when making a turn. The way this mix works is as you move the aileron stick left or right, the rudder will move as well giving you a little more control on your turns. Always have the rudder move in the same direction as the aileron. You may want to start with a small amount of mix to start with and adjust as needed after a flight.

Remember: when setting a aileron to rudder mix, it will be active at all times You do not have a switch to turn it off.

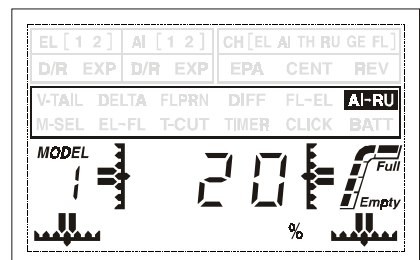

To use AL-RU mixing, move the cursor to the AL-RU using the FUNCTION keys. Next use the INC+ or DEC- keys to change percentage of rudder movement.

# VG6000

## MODEL SELECT ( M-SEL )

The VG6000 computer radio system comes with 4 model memory. This allows you to have 4 completely separate models using one transmitter.

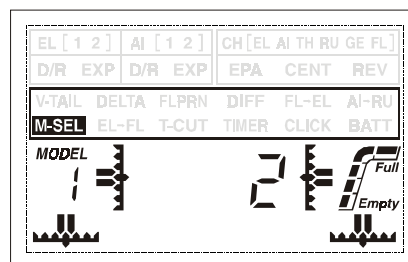

To change models, move the cursor to the M-SEL using the FUNCTION keys. Next use the INC+ or DEC- keys to select models 1~4.

All settings are saved automatically on all models. All trims, mixes, servo directions, etc. are saved as you set them. The VG6000 will not lose any memory even if you were to remove the main battery. All your settings are saved in a eeprom chip that does not need any type of battery to hold its memory.

## ELEVATOR TO FLAP MIXING ( EL-FL )

Elevator to flap mixing can be used in several aircraft. Sailplanes like this feature when they are making a turn it will drop the flaps slightly to help generate a little more lift. Power aircraft will benefit this when making landing approaches and when flaring the aircraft just before touch down. Adding flaps as needed on landings will help out any landing.

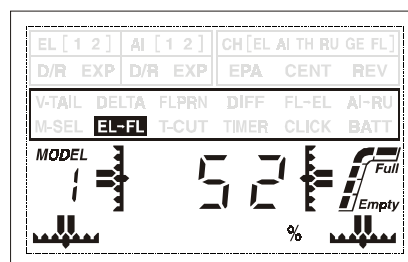

To use EL-FL mixing, move the cursor to the EL-FL using the FUNCTION keys. Next use the INC+ or DEC- keys to change percentage of flap movement.

Elevator to Flap mixing will also work if Flaperons are activated. Default is "0" settings are from 100 to -100.

## THROTTLE CUT ( T-CUT )

After you have landed and taxied back, you can shoot your engine off by simply pushing a button. The throttle cut feature will do just that. To set your throttle cut first you must make sure the throttle is working properly and it will come to a low idle. No more need to use the trim to shoot your engine off.

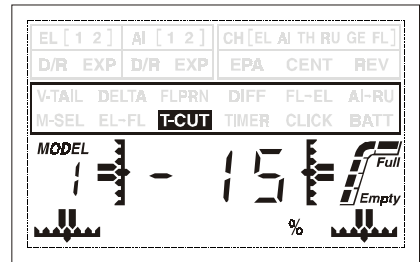

To use T-CUT, move the cursor to the T-CUT using the FUNCTION keys. Next use the INC+ or DEC- keys to change the percentage of throttle cut needed. Throttle cut only works when the stick is in the low position. Make sure the throttle barrel on your engine will go below the lowest idle position before adjusting throttle cut. Default is "0" setting are from 15 to -15

## COUNT DOWN TIMER ( TIMER )

Count down timers help to remind you that it's time to land meaning lets get it down before we run out of fuel. If you know how long a normal flight is on your aircraft "example" 15:00 minutes, you can set the down timer to sound off at 13:00 minutes. This will give you approximately 2:00 minutes to land with some fuel left over in-case you need to do a go around. Timer can be set from 0 to 60:00 minutes and are set in 10 seconds intervals.

Example: the left two numbers represent 0-60 minutes and the number on the right represent 10th's. 10, 20, 30, 40, 50.

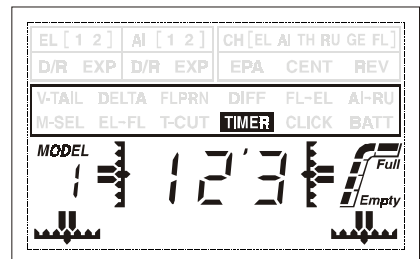

After the timer has reached "0", it will start to count up. At every minute you will hear 2 beeps.

To set the timer first move the cursor to TIMER using the FUNCTION keys. Number will be flashing 00'0. Use the INC+ key to set the amount of time. Example: timer reads 01'3, this will give you a count down 1 minute 30 seconds.

Pressing the CH/TIMER button will start the count down timer. At the end of the count down you will hear a series of beeps starting at the last 10 seconds of the count down.

To stop the timer at anytime simply push the CH/TIMER button. To restart push it again.

To reset the timer simply press both INC+ and DEC- at the same time.

To reset the timer to 00'0 simply press both INC+ and DEC- again. ( 2 times )

# VG6000

## SOUND CLICK (CLICK)

This feature will allow you to turn off or on the beep sound you hear when you do any adjustments to the transmitter programming. In the off position it will turn off the beep you hear when you do any adjustments to the digital trims.

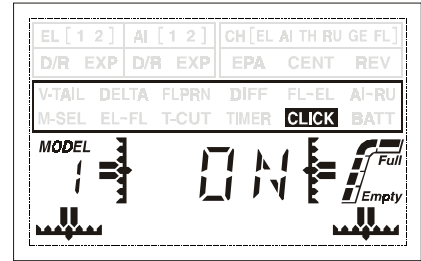

To change the CLICK settings, move the cursor to the CLICK using the FUNCTION keys. Next use the INC+ or DEC- keys to change it from on to off.

## BATTERY VOLTAGE DISPLAY (BATT)

The Battery numeric display will give you the exact voltage of your battery and to the right of the LCD screen you can see the battery graph showing full to empty. At a full charge you may see the voltage be as high as 11.4.

A low battery beeper with sound when the battery reaches 9.1 volts. Land immediately if you hear the low battery warning beep.

DO NOT FLY IF BATTERY VOLTAGE IS LOW.

Your battery is rated at 9.6 volts. On a fully charge battery, you may see the voltage as high as 11.4 but never fly after the battery reaches below 9.5. Always recharge at this point.

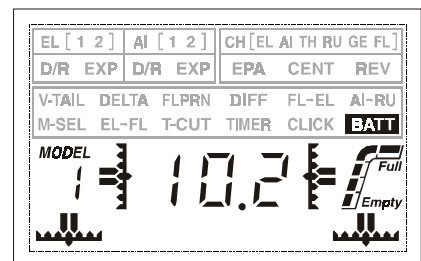

Altronics has 3 transmitter batteries that can be used in the VG6000

|                     |         |
|---------------------|---------|
| 700 MAh Sport Pack  | # 95090 |
| 600 MAh Sanyo Pack  | # 95010 |
| 1100 MAh Sanyo Pack | # 95052 |

# VG6000

MODEL #.....MODEL NAME.....

NOTES:

|            |   |
|------------|---|
| EL D/R (1) | % |
| EL D/R (2) | % |

|             |   |
|-------------|---|
| EL Expo (1) | % |
| EL Expo (2) | % |

|            |   |
|------------|---|
| AL D/R (1) | % |
| AL D/R (2) | % |

|             |   |
|-------------|---|
| AL Expo (1) | % |
| AL Expo (2) | % |

|      | EPA |     | CENT |   | REV       |
|------|-----|-----|------|---|-----------|
| 1 EL | ↑   | % ↓ | %    | % | NOR / REV |
| 2 AL | ←   | % → | %    | % | NOR / REV |
| 3 TH | ↑   | % ↓ | %    | % | NOR / REV |
| 4 RU | ←   | % → | %    | % | NOR / REV |
| 5 G  | ↑   | % ↓ | %    | % | NOR / REV |
| 6 FL | ↑   | % ↓ | %    | % | NOR / REV |

|              |          |
|--------------|----------|
| V-Tail       | OFF / ON |
| Delta        | OFF / ON |
| Flaperons    | OFF / ON |
| Differential | %        |
| FL - EL Mix  | %        |
| AL - RU Mix  | %        |
| EL - FL Mix  | %        |
| T-Cut        | %        |
| Timer        | min sec  |
| Click        | OFF / ON |

**Airtronics Inc**  
 1185 Stanford Court  
 Anaheim, CA 92805  
 PH: 714-978-1895 FAX: 714-978-1540  
 Web Site: [www.Airtronics.net](http://www.Airtronics.net)  
 e-mail: [info@Airtronics.net](mailto:info@Airtronics.net)