

# MICRO-HELICOPTER **T-REX 250 SE** KIT

KX019004T

## INSTRUCTION MANUAL

## 使用說明書

# ALIGN

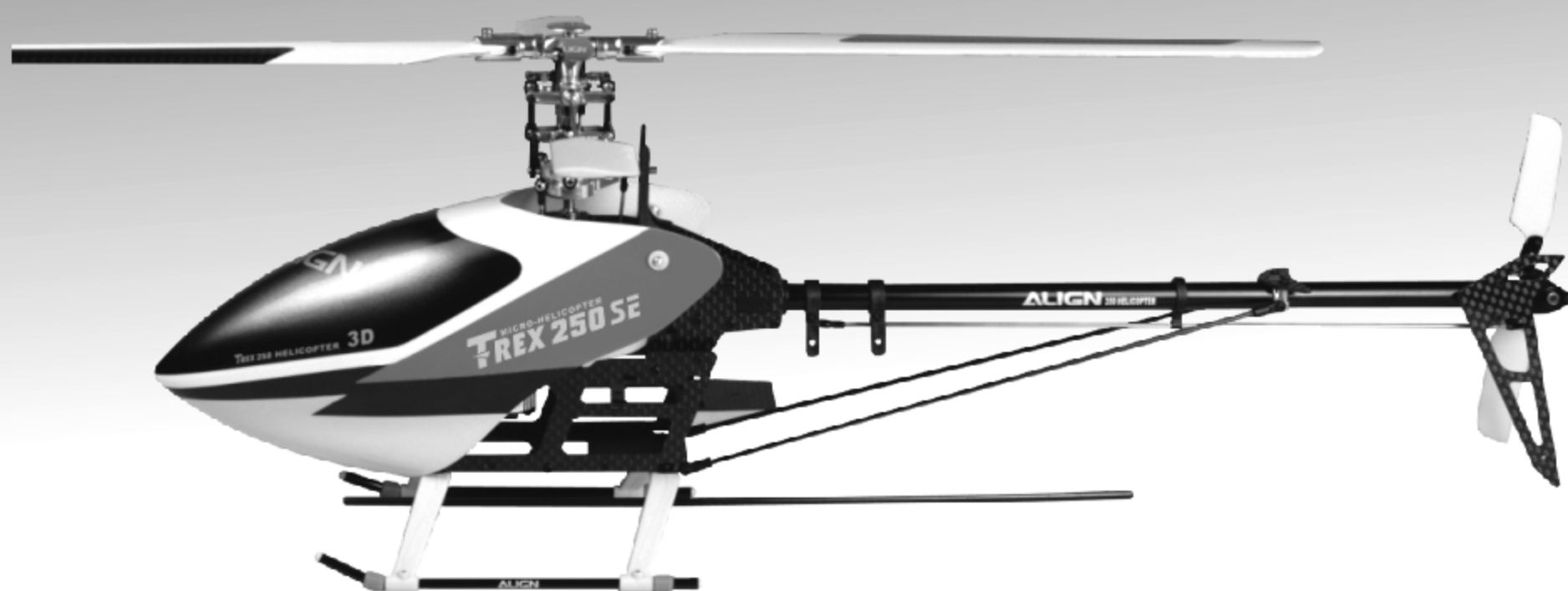

Thank you for buying ALIGN products. The **T-REX 250 SE** is the latest technology in Rotary RC models. Please read this manual carefully before assembling and flying the new **T-REX 250 SE** helicopter. We recommend that you keep this manual for future reference regarding tuning and maintenance.

承蒙閣下選用亞拓遙控世界系列產品，謹表謝意。進入遙控世界之前必須告訴您許多相關的知識與注意事項，以確保您能夠在學習的過程中較得心應手。在開始操作之前，請務必詳閱本說明書，相信一定能夠給您帶來相當大的幫助，也請您妥善保管這本說明書，以作為日後參考。

### Contents

1	INTRODUCTION 前言
1~2	SAFETY NOTES 安全注意事項
3	EQUIPMENT REQUIRED FOR ASSEMBLY 自備設備
4	SAFETY CHECK BEFORE FLYING 飛行前安全檢查重要事項
5~16	ASSEMBLY SECTION 組裝說明
17	EQUIPMENT ILLUSTRATION 設備建議配置圖示
18	GYRO INSTALLTION SUGGESTION 陀螺儀安裝建議位置
18	DIAL PITCH GAUGE PAD INSTRUCTION 可調式螺距規墊塊使用說明
19	SERVO SETTING AND ADJUSTMENT 伺服器設定調整
19	ADJUSTMENTS FOR GYRO AND TAIL NEUTRAL SETTING 陀螺儀與尾翼中立點調整
20	PITCH AND THROTTLE SETTING 主旋翼螺距與油門設定
21	POWER COLLOCATION REFERENCE 原裝動力數據參考表
21~25	RCE-BL15K BRUSHLESS SPEED CONTROLLER INSTRUCTION MANUAL 無刷調速器使用說明
26~30	FLIGHT ADJUSTMENT AND SETTING 飛行動作調整與設定
31~38	PART NAMES AND OPTIONAL PART LIST 各部零件名稱與選購備品明細

Thank you for buying ALIGN Products. The T-REX 250 Helicopter is designed as an easy to use, full featured Helicopter R/C model capable of all forms of rotary flight. Please read the manual carefully before assembling the model, and follow all precautions and recommendations located within the manual. Be sure to retain the manual for future reference, routine maintenance, and tuning. The T-REX 250 is a new product developed by ALIGN.

It features the best design available on the Micro-Heli market to date, providing flying stability for beginners, full aerobatic capability for advanced fliers, and unsurpassed reliability for customer support.

感謝您選購亞拓產品，為了讓您容易方便的使用 T-REX 250 直昇機、請您詳細的閱讀完這本說明書之後再進行組裝以及操作這台直昇機，同時請您妥善的保存這本說明書、作為日後進行調整以及維修的參考。T-REX 250 是由亞拓自行研發的新產品，不論你是需求飛行穩定性的初學者或是追求性能的飛行愛好者。T-REX 250 將是你最佳的選擇。

### THE MEANING OF SYMBOLS 標誌代表涵義

 <b>WARNING</b> 警告	<b>Mishandling due to failure to follow these instructions may result in damage or injury.</b> 因為疏忽這些操作說明，而使用錯誤可能造成財產損失或嚴重傷害。
 <b>CAUTION</b> 注意	<b>Mishandling due to failure to follow these instructions may result in danger.</b> 因為疏忽這些操作說明，而使用錯誤可能造成危險。
 <b>FORBIDDEN</b> 禁止	<b>Do not attempt under any circumstances.</b> 在任何禁止的環境下，請勿嘗試操作。

### IMPORTANT NOTES 重要聲明

R/C helicopters, including the T-REX 250 are not toys. R/C helicopter utilize various high-tech products and Technologies to provide superior performance. Improper use of this product can result in serious injury or even death. Please read this manual carefully before using and make sure to be conscious of your own personal safety and the safety of others and your environment when operating all ALIGN products.

Manufacturer and seller assume no liability for the operation or the use of this product.

Intended for use only by adults with experience flying remote control helicopters at a legal flying field. After the sale of this product we cannot maintain any control over its operation or usage.

T-REX 250 遙控直昇機並非玩具，它是結合了許多高科技產品所設計出來的休閒用品，所以商品的使用不當或不熟悉都可能造成嚴重傷害甚至死亡，使用之前請務必詳讀本說明書，勿輕忽並注意自身安全。注意！任何遙控直昇機的使用，製造商和經銷商是無法對使用者於零件使用的損耗異常或組裝不當所發生之意外負任何責任，本產品是提供給有操作過模型直昇機經驗的成人或有相當技術的人員在旁指導於當地合法遙控飛行場飛行，以確保安全無虞下操作使用，產品售出後本公司將不負任何操作和使用控制上的任何性能與安全責任。

We recommend that you obtain the assistance of an experienced pilot before attempting to fly our products for the first time. A local expert is the best way to properly assemble, setup, and fly your model for the first time. The T-REX 250 requires a certain degree of skill to operate, and is a consumer item. Any damage or dissatisfaction as a result of accidents or modifications are not covered by any warrantee and cannot be returned for repair or replacement. Please contact our distributors for free technical consultation and parts at discounted rates when you experience problems during operation or maintenance.

模型商品屬於需高操作技術且為消耗性之商品，如經拆裝使用後，會造成不等情況零件損耗，任何使用情況所造成商品不良或不滿意，將無法於保固條件內更換新品或退貨，如遇有使用操作維修問題，本公司全省分公司或代理商將提供技術指導、特價零件供應服務。

## 2. SAFETY NOTES 安全注意事項



**Fly only in safe areas, away from other people. Do not operate R/C aircraft within the vicinity of homes or crowds of people. R/C aircraft are prone to accidents, failures, and crashes due to a variety of reasons including, lack of maintenance, pilot error, and radio interference. Pilots are responsible for their actions and damage or injury occurring during the operation or as of a result of R/C aircraft models.**

遙控模型飛機、直昇機屬高危險性商品，飛行時務必遠離人群，人為組裝不當或機件損壞、電子控制設備不良，以及操控上的不熟悉、都有可能導致飛行失控損傷等不可預期的意外，請飛行者務必注意飛行安全，並需了解自負疏忽所造成任何意外之責任。



### LOCATE AN APPROPRIATE LOCATION 遠離障礙物及人群

R/C helicopters fly at high speed, thus posing a certain degree of potential danger. Choose an a legal flying field consisting of flat, smooth ground without obstacles. Do not fly near buildings, high voltage cables, or trees to ensure the safety of yourself, others and your model. For the first practice, please choose a legal flying field and can use a training skid to fly for reducing the damage. Do not fly your model in inclement weather, such as rain, wind, snow or darkness.

直昇機飛行時具有一定的速度，相對的也潛在著危險性，場地的選擇也相對的重要，請需遵守當地法規到合法遙控飛行場地飛行。必須注意周遭有沒有人、高樓、建築物、高壓電線、樹木等等，避免操控的不當造成自己與他人財產的損壞。初次練習時，務必選擇在空曠合法專屬飛行場地並適當搭配練習架練習飛行，這對飛行失誤所造成的損傷將會大幅的降低。請勿在下雨、打雷等惡劣天候下操作，以確保本身及機體的安全。



### PREVENT MOISTURE 遠離潮濕環境

R/C models are composed of many precision electrical components.

It is critical to keep the model and associated equipment away from moisture and other contaminants. The introduction or exposure to water or moisture in any form can cause the model to malfunction resulting in loss of use, or a crash. Do not operate or expose To rain or moisture.

直昇機內部也是由許多精密的電子零組件組成，所以必須絕對的防止潮濕或水氣，避免在浴室或雨天時使用，防止水氣進入機身內部而導致機件及電子零件故障而引發不可預期的意外！



### PROPER OPERATION 勿不當使用本產品

Please use the replacement of parts on the manual to ensure the safety of instructors. This product is for R/C model, so do not use for other purpose.

請勿自行改造加工，任何的升級改裝或維修，請使用亞拓產品目錄中的零件，以確保結構的安全。請確認於產品限界內操作，請勿過載使用，並勿用於安全、法令外其它非法用途。



### OBTAIN THE ASSISTANCE OF AN EXPERIENCED PILOT 避免獨自操控

Before turning on your model and transmitter, check to make sure no one else is operating on the same frequency. Frequency interference can cause your model, or other models to crash. The guidance provided by an experienced pilot will be invaluable for the assembly, tuning, trimming, and actual first flight. (Recommend you to practice with computer-based flight simulator.)

至飛行場飛行前，需確認是否有相同頻率的同好正進行飛行，因為開啓相同頻率的發射機將導致自己與他人立即干擾等意外危險。遙控飛機操控技巧在學習初期有著一定的難度，要盡量避免獨自操作飛行，需有經驗的人士在旁指導，才可以操控飛行。(勤練電腦模擬器及老手指導是入門必要的選擇)



### SAFE OPERATION 安全操作

Operate this unit within your ability. Do not fly under tired condition and improper operation may cause in danger.

請於自己能力內及需要一定技術範圍內操作這台直昇機，過於疲勞、精神不佳或不當操作，意外發生風險將可能會提高。



### ALWAYS BE AWARE OF THE ROTATING BLADES 遠離運轉中零件

During the operation of the helicopter, the main rotor and tail rotor will be spinning at a high rate of speed. The blades are capable of inflicting serious bodily injury and damage to the environment. Be conscious of your actions, and careful to keep your face, eyes, hands, and loose clothing away from the blades. Always fly the model a safe distance from yourself and others, as well as surrounding objects. Never take your eyes off the model or leave it unattended while it is turned on. Immediately turn off the model and transmitter when you have landed the model.

當直昇機主旋翼與尾旋翼運轉時，切勿觸摸並遠離任何物件，以避免造成危險及損壞。



### KEEP AWAY FROM HEAT 遠離熱源

R/C models are made up various forms of plastic. Plastic is very susceptible to damage or deformation due to extreme heat and cold climate. Make sure not to store the model near any source of heat such as an oven, or heater. It is best to store the model indoors, in a climate-controlled, room temperature environment.

遙控飛機多半是以 PA 纖維或聚乙烯、電子商品為主要材質，因此要盡量遠離熱源、日曬，以避免因高溫而變形甚至熔毀損壞的可能。





## CAREFULLY INSPECT BEFORE REAL FLIGHT 實機飛行前請嚴格執行飛行前檢查義務

- ☆ Before flying, please check to make sure no one else is operating on the same frequency for the safety.
- ☆ Before flight, please check if the batteries of transmitter and receiver are enough for the flight.
- ☆ Before turn on the transmitter, please check if the throttle stick is in the lowest position. IDLE switch is OFF.
- ☆ When turn off the unit, please follow the power on/off procedure. Power ON- Please turn on the transmitter first, and then turn on receiver. Power OFF- Please turn off the receiver first and then turn off the transmitter. Improper procedure may cause out of control, so please to have this correct habit.
- ☆ Before operation, check every movement is smooth and directions are correct. Carefully inspect servos for interference and broken gear.
- ☆ Check for missing or loose screws and nuts. See if there is any cracked and incomplete assembly of parts. Carefully check main rotor blades and rotor holders. Broken and premature failures of parts possibly cause resulting in a dangerous situation.
- ☆ Check all ball links to avoid excess play and replace as needed. Failure to do so will result in poor flight stability.
- ☆ Check the battery and power plug are fastened. Vibration and violent flight may cause the plug loose and result out of control.
- ★ 每次飛行前應先確認所使用的頻率是否會干擾他人，以確保你自身與他人的安全。
- ★ 每次飛行前確定您發射機與接收機電池的電量是在足夠飛行的狀態。
- ★ 開機前確認油門搖桿是否位於最低點，熄火降落開關，定速開關(IDLE)是否於關閉位置。
- ★ 關機時必須遵守電源開關機的程序，開機時應先開啓發射機後，再開啓接收機電源；關機時應先關閉接收機後，再關閉發射機電源。不正確的開關程序可能會造成失控的現象，影響自身與他人的安全，請養成正確的習慣。
- ★ 開機請先確定直昇機的各個動作是否順暢，及方向是否正確，並檢查伺服器的動作是否有干涉或崩齒的情形，使用故障的伺服器將導致不可預期的危險。
- ★ 飛行前確認沒有缺少或鬆脫的螺絲與螺帽，確認沒有組裝不完整或損毀的零件，仔細檢查主旋翼是否有損壞，特別是接近主旋翼夾座的部位。損壞或組裝不完整的零件不僅影響飛行，更會造成不可預期的危險。注意：對損耗、有裂痕零件更新及定期保養檢查的重要性。
- ★ 檢查所有的連桿頭是否有鬆脫的情形，過鬆的連桿頭應先更新，否則將造成直昇機無法操控的危險。
- ★ 確認電池及電源接頭是否固定牢靠，飛行中的震動或激烈的飛行，可能造成電源接頭鬆脫而造成失控的危險。

### Standard Equipment 標準配備

<b>250HC2</b>	<b>250HH8</b>	<b>250HB3</b>	<b>250HB2</b>	<b>250HT5</b>	<b>250HT3</b>
<b>250HG2</b>	<b>250HZ</b>	<b>15T x 1 Motor Pinion Gear x 1pc</b> 馬達主齒 x 1	<b>RCM-BL250SP 3400KV Brushless motor x 1</b> RCM-BL250SP 3400KV無刷馬達 x 1	<b>RCE-BL15X Brushless ESC x 1</b> RCE-BL15X 15安培無刷調速器 x 1	
<b>205D Carbon Fiber Blades x 1 set</b> 205D碳纖主旋翼 x 1		<b>205 Main Blade x 1 set</b> 205主旋翼 x 1		<b>#00 Philips Screw Driver x 1</b> #00十字螺絲起子 x 1	<b>0.9mm Hex head wrench x 1</b> 0.9mm L型六角扳手 x 1
		<b>1.3mm Hexagon Screw Driver x 1</b> 1.3mm六角螺絲起子 x 1	<b>Clip x 1</b> 零件夾 x 1	<b>Dial Pitch Gauge Pad x 1</b> 可調式螺距規墊塊 x 1	

When you see the marks as below, please use glue or grease to ensure flying safety.

標有下符號之組裝步驟，請配合上膠或上油，以確保使用之可靠度。

- CA: Apply CA Glue to fix.
- R48: Apply Anaerobics Retainer to fix.
- T22: Apply Thread Lock to fix.
- OIL: Add Grease.

CA: 使用瞬間膠固定  
R48: 使用金屬管狀固定缺氧膠固定  
T22: 使用螺絲膠  
OIL: 添加潤滑油

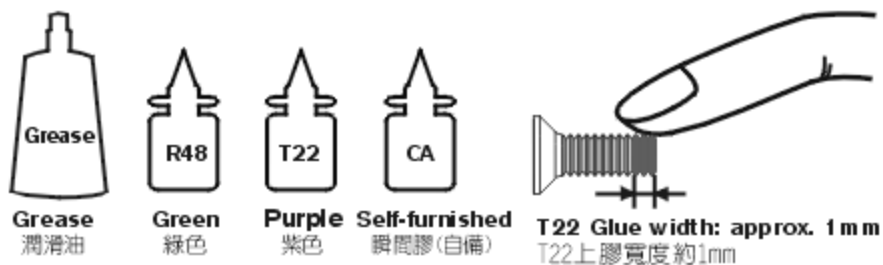

R48 metal tubular adhesive (eg. Bearings). T22 thread lock, apply a small amount on screws or metal parts and wipe surplus off. When disassembling, recommend to heat the metal joint about 15 Seconds.  
(NOTE: Keep plastic parts away from heat.)

R48 為強力金屬管狀(如軸承)接著劑，T22為螺絲膠，膠合螺絲或金屬內外徑請務必少量使用，必要時請用手去除多餘膠量，欲拆卸時可於金屬接合部位熱烤約15秒。(注意！塑膠件避免接近熱源)









When assembling ball links, make sure the "A" character faces outside.

各項塑膠製連桿頭扣接時，A字請朝外。

## CAREFULLY INSPECT BEFORE REAL FLIGHT 實機飛行前請嚴格執行飛行前檢查義務

- ☆ Before flying, please check to make sure no one else is operating on the same frequency for the safety.
- ☆ Before flight, please check if the batteries of transmitter and receiver are enough for the flight.
- ☆ Before turn on the transmitter, please check if the throttle stick is in the lowest position. IDLE switch is OFF.
- ☆ When turn off the unit, please follow the power on/off procedure. Power ON- Please turn on the transmitter first, and then turn on receiver. Power OFF- Please turn off the receiver first and then turn off the transmitter. Improper procedure may cause out of control, so please to have this correct habit.
- ☆ Before operation, check every movement is smooth and directions are correct. Carefully inspect servos for interference and broken gear.
- ☆ Check for missing or loose screws and nuts. See if there is any cracked and incomplete assembly of parts. Carefully check main rotor blades and rotor holders. Broken and premature failures of parts possibly cause resulting in a dangerous situation.
- ☆ Check all ball links to avoid excess play and replace as needed. Failure to do so will result in poor flight stability.
- ☆ Check the battery and power plug are fastened. Vibration and violent flight may cause the plug loose and result out of control.
- ★ 每次飛行前應先確認所使用的頻率是否會干擾他人，以確保你自身與他人的安全。
- ★ 每次飛行前確定您發射機與接收機電池的電量是在足夠飛行的狀態。
- ★ 開機前確認油門搖桿是否位於最低點，熄火降落開關，定速開關(IDLE)是否於關閉位置。
- ★ 關機時必須遵守電源開關機的程序，開機時應先開啓發射機後，再開啓接收機電源；關機時應先關閉接收機後，再關閉發射機電源。不正確的開關程序可能會造成失控的現象，影響自身與他人的安全，請養成正確的習慣。
- ★ 開機請先確定直昇機的各個動作是否順暢，及方向是否正確，並檢查伺服器的動作是否有干涉或崩齒的情形，使用故障的伺服器將導致不可預期的危險。
- ★ 飛行前確認沒有缺少或鬆脫的螺絲與螺帽，確認沒有組裝不完整或損毀的零件，仔細檢查主旋翼是否有損壞，特別是接近主旋翼夾座的部位。損壞或組裝不完整的零件不僅影響飛行，更會造成不可預期的危險。注意：對損耗、有裂痕零件更新及定期保養檢查的重要性。
- ★ 檢查所有的連桿頭是否有鬆脫的情形，過鬆的連桿頭應先更新，否則將造成直昇機無法操控的危險。
- ★ 確認電池及電源接頭是否固定牢靠，飛行中的震動或激烈的飛行，可能造成電源接頭鬆脫而造成失控的危險。

### Standard Equipment 標準配備

 <b>250HC2</b>	 <b>250HH8</b>	 <b>250HB3</b>	 <b>250HB2</b>	 <b>250HT5</b>	 <b>250HT3</b>
 <b>250HG2</b>	 <b>15T x 1 Motor Pinion Gear x 1pc 馬達主齒 x 1</b>				

When you see the marks as below, please use glue or grease to ensure flying safety.

標有下符號之組裝步驟，請配合上膠或上油，以確保使用之可靠度。



- CA:** Apply CA Glue to fix.
- R48:** Apply Anaerobics Retainer to fix.
- T22:** Apply Thread Lock to fix.
- OIL:** Add Grease.
- CA: 使用瞬間膠固定
- R48: 使用金屬管狀固定缺氧膠固定
- T22: 使用螺絲膠
- OIL: 添加潤滑油

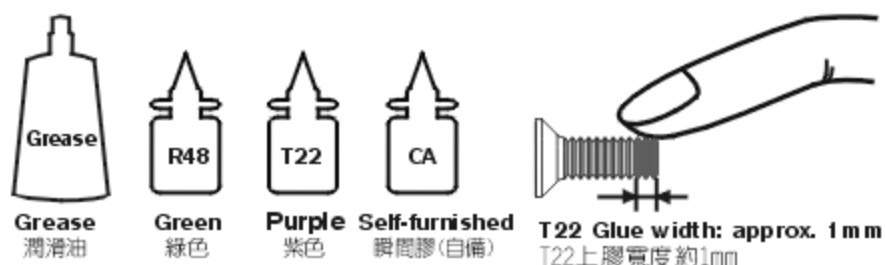

R48 metal tubular adhesive (eg. Bearings). T22 thread lock, apply a small amount on screws or metal parts and wipe surplus off. When disassembling, recommend to heat the metal joint about 15 Seconds.  
(NOTE: Keep plastic parts away from heat.)

When assembling ball links, make sure the "A" character faces outside.  
各項塑膠製連桿頭扣接時，A字請朝外。

R48 為強力金屬管狀(如軸承)接著劑，T22為螺絲膠，膠合螺絲或金屬內外徑請務必少量使用，必要時請用手去除多餘膠量，欲拆卸時可於金屬接合部位熱烤約15秒。(注意！塑膠件避免接近熱源)



**CAUTION 注意**  
 For original manufactory package, if the product is already assembled by Factory, please check again if screws are firmly secured and applied with some glue.  
 原廠零件出廠包裝如果是組裝品，請需再確認各螺絲是否鎖緊上膠。

When tightening a screw to a plastic part, please tighten it firmly, but not over tightened, or they will strip.  
 螺絲鎖入塑膠件請務必注意，適當扭力鎖緊即可，而過緊的扭力可能會導致滑牙。

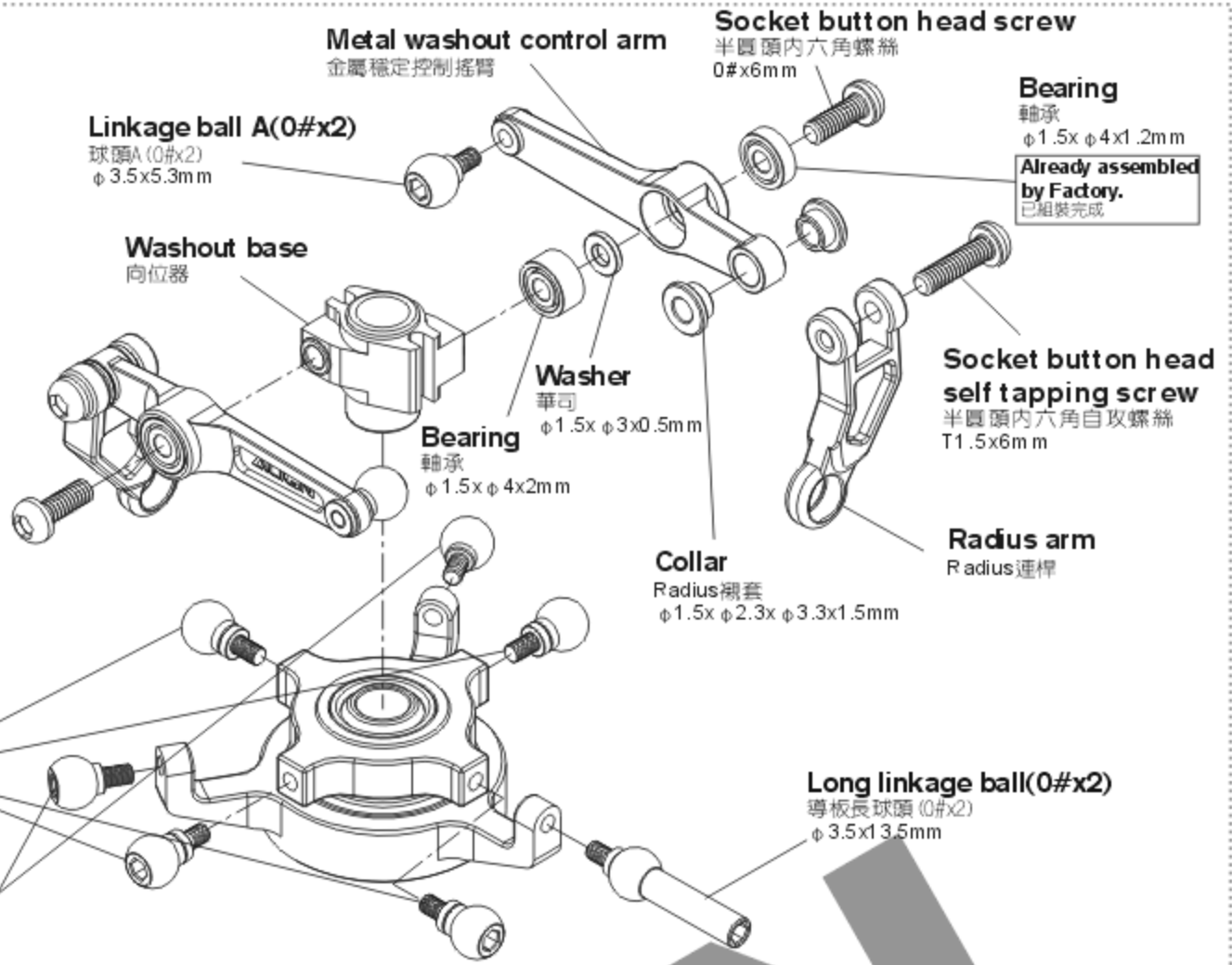

**250HH8**

- Socket button head self tapping screw**  
半圓頭內六角自攻螺絲(T1.5x6mm) x 2
- Washer**  
華司(φ1.5x φ3x0.5mm) x 2
- Bearing**  
軸承(φ1.5x φ4x1.2mm) x 2
- Bearing**  
軸承(φ1.5x φ4x2mm) x 2
- Socket button head screw**  
半圓頭內六角螺絲(0#x6mm) x 3
- Long linkage ball(0#x2)**  
導板長球頭(0#x2)(φ3.5x13.5mm) x 1
- Linkage ball A(0#x2)**  
球頭A(0#x2)(φ3.5x5.3mm) x 4
- Linkage ball A(0#x2)**  
球頭D(0#x2)(φ3.5x6mm) x 4

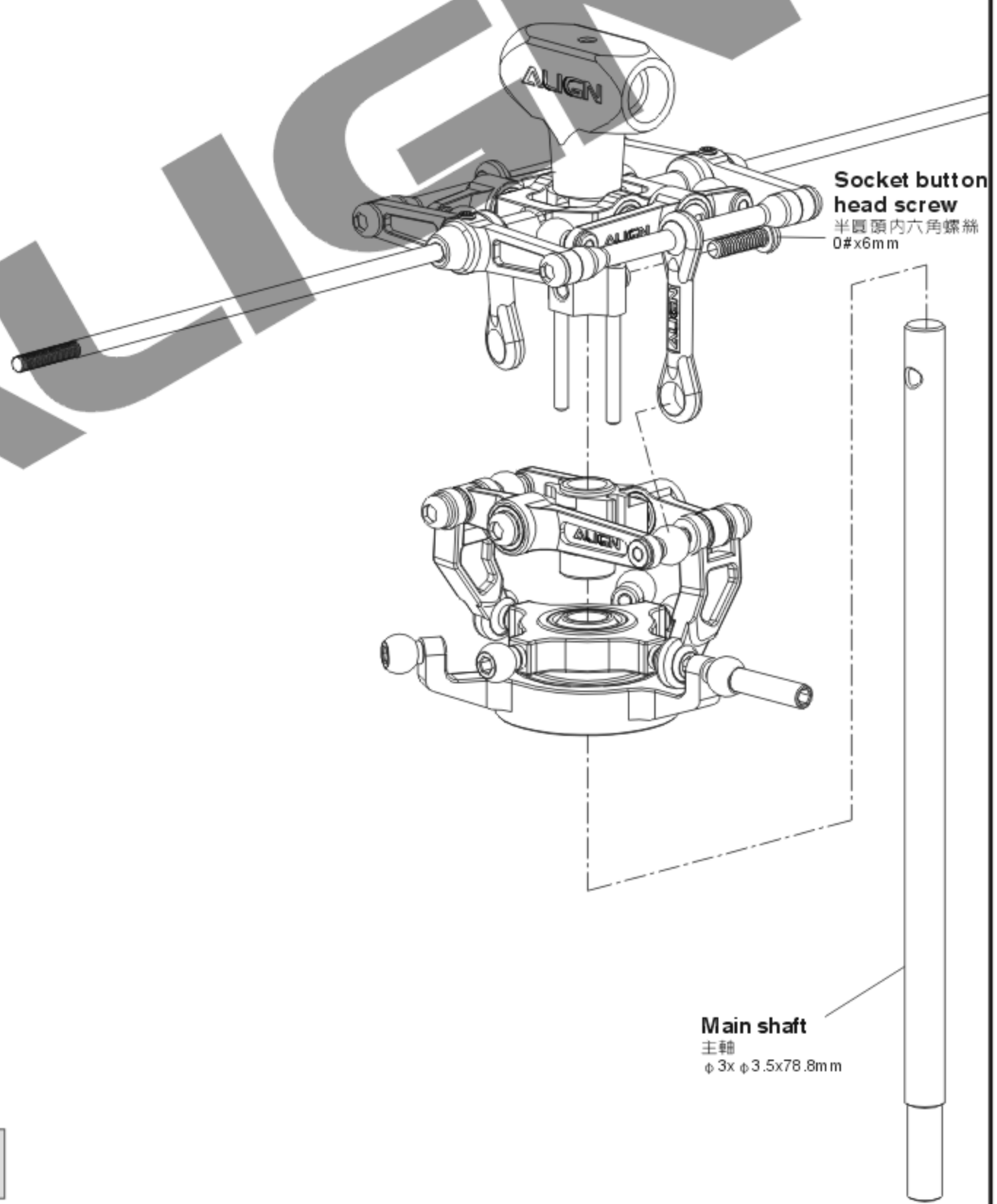





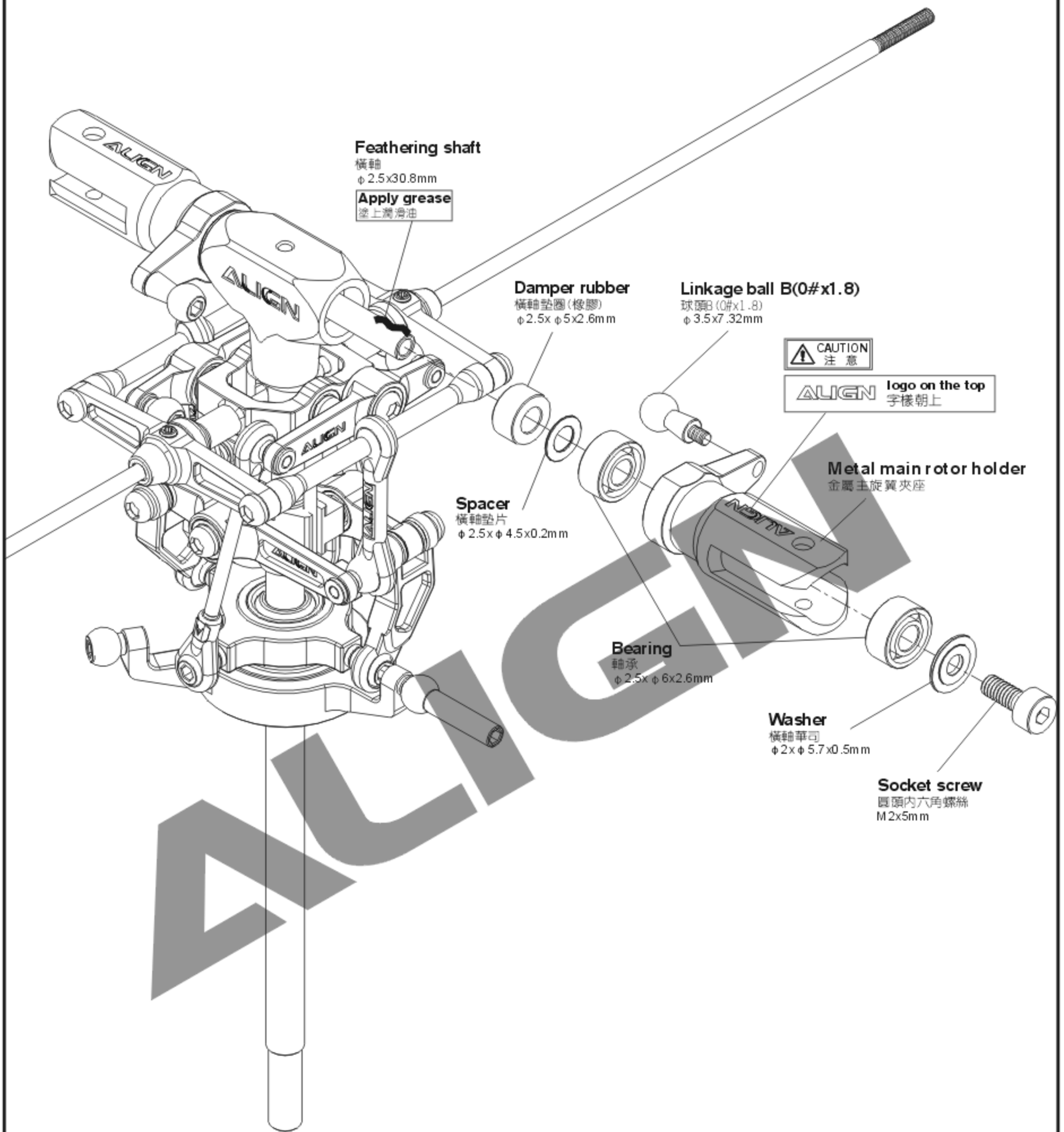

**Apply a little amount of T22 thread lock when fixing a metal part.**  
螺絲鎖對於金屬件請使用適量T22(螺絲膠)

 **Apply a little amount of T22 thread lock when fixing a metal part.**  
螺絲鎖附於金屬件請使用適量T22(螺絲膠)



**250HH8**

- |   |   |
|---|---|
|  |  |
| <b>Bearing</b><br>軸承(φ 2.5x φ 6x2.6mm) x 4  | <b>Damper rubber</b><br>橫軸墊圈(橡膠)(φ 2.5x φ 5x2.6mm) x 2                              |
|  |  |
| <b>Socket screw</b><br>圓頭內六角螺絲(M2x5mm) x 2  | <b>Washer</b><br>橫軸華司(φ 2x φ 5.7x0.5mm) x 2   |
|  |  |
| <b>Linkage ball B(0#x1.8)</b><br>球頭B(0#x1.8)(φ 3.5x7.32mm) x 2                      | <b>Spacer</b><br>橫軸墊片(φ 2.5x φ 4.5x0.2mm) x 2                                       |

 **CAUTION**  
注意

**When tightening a screw to a plastic part, please tighten it firmly, but not over tightened, or they will strip.**  
螺絲鎖入塑膠件請務必注意，適當扭力鎖緊即可，而過緊的扭力可能會導致滑牙。

**For original manufactory package, if the product is already assembled by Factory, please check again if screws are firmly secured and applied with some glue.**  
原廠零件出廠包裝如果是組裝品，請需再確認各螺絲是否鎖緊上膠。



**Apply a little amount of T22 thread lock when fixing a metal part.**  
 螺絲鎖對於金屬件請使用適量T22 (螺絲膠)

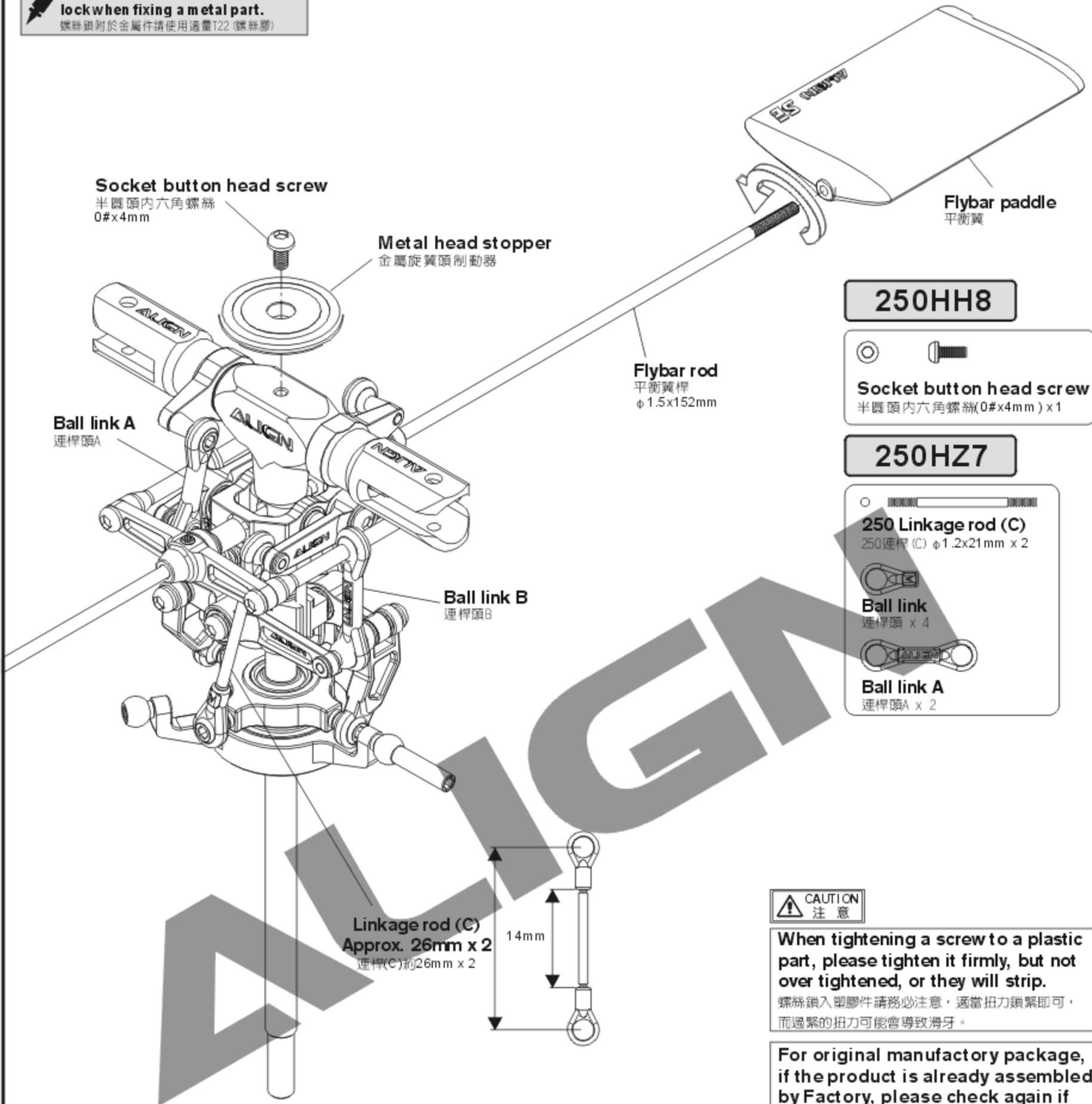

**250HH8**

- Socket button head screw  
半圓頭內六角螺絲(0#x4mm) x1

**250HZ7**

- 250 Linkage rod (C)  
250連桿(C) φ1.2x21mm x 2
- Ball link  
連桿頭 x 4
- Ball link A  
連桿頭A x 2

**CAUTION**  
注意

**When tightening a screw to a plastic part, please tighten it firmly, but not over tightened, or they will strip.**  
 螺絲鎖入塑膠件請務必注意，適當扭力鎖緊即可，而過緊的扭力可能會導致滑牙。

**For original manufactory package, if the product is already assembled by Factory, please check again if screws are firmly secured and applied with some glue.**  
 原廠零件出廠包裝如果是組裝品，請需再確認各螺絲是否鎖緊上膠。

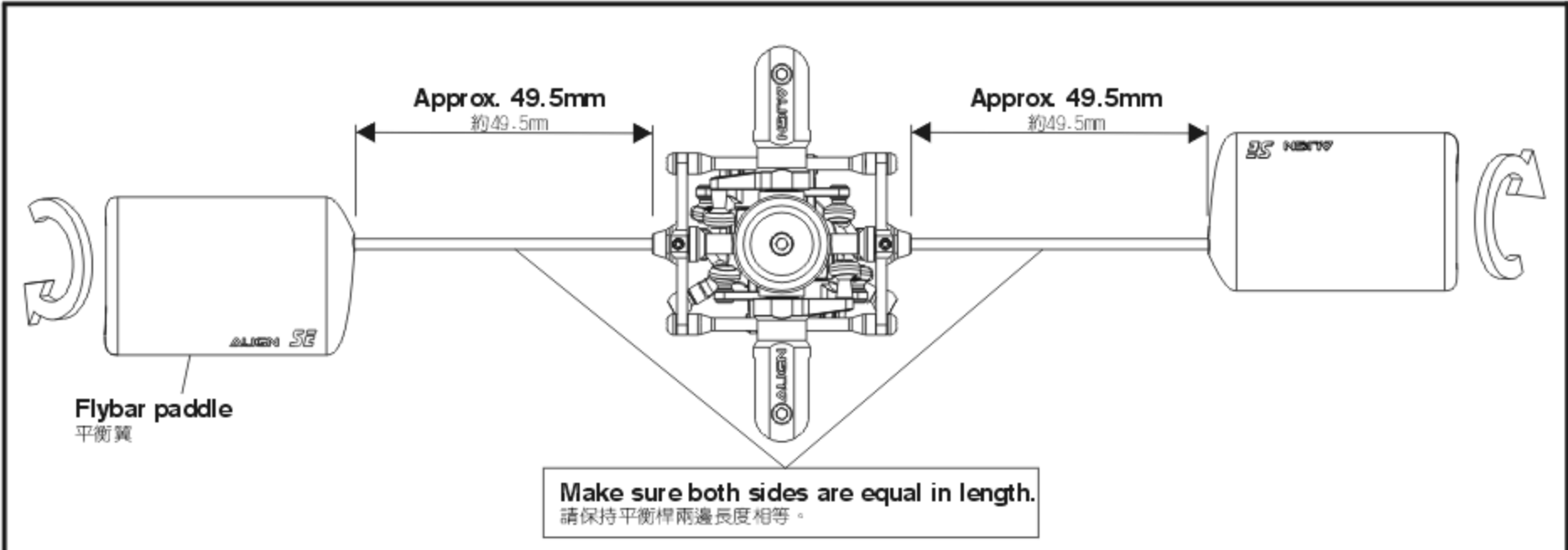

## 250HZ7

**Socket button head self tapping screw**  
半圓頭內六角自攻螺絲(T2x8mm) x 6

**Linkage ball B(0#x1.8)**  
球頭B(0#x1.8)( $\phi$  3.5x7.32mm) x 2

**Linkage ball A(0#x2)**  
球頭A(0#x2)( $\phi$  3.5x5.3mm) x 1

**Socket button head self tapping screw**  
半圓頭內六角自攻螺絲 T2x8mm

**Plastic nut**  
伺服器固定螺帽

**Linkage ball B(0#x1.8)**  
球頭B(0#x1.8)  
 $\phi$  3.5x7.32mm

**Socket button head self tapping screw**  
半圓頭內六角自攻螺絲 T2x8mm

**Linkage ball A(0#x2)**  
球頭A(0#x2)  
 $\phi$  3.5x5.3mm

**Carbon fiber upper frame**  
碳纖上側板  
110.49x42.6x1.2mm

**Linkage ball B(0#x1.8)**  
球頭B(0#x1.8)  
 $\phi$  3.5x7.32mm

**Servo**  
伺服器

**Apply a little amount of T22 thread lock when fixing a metal part.**  
螺絲鎖附於金屬件請使用適量T22(螺絲膠)

## 250HB3

**Socket button head self tapping screw**  
半圓頭內六角自攻螺絲(T1.5x3mm) x 12

**Bearing**  
軸承( $\phi$  3.5x $\phi$  7x2.5mm) x 2

**Socket button head screw**  
半圓頭內六角螺絲(0#x3mm) x 12

**Socket button head screw**  
半圓頭內六角螺絲(0#x3mm) x 2

**Socket button head screw**  
半圓頭內六角螺絲  
0#x3mm

**Countersunk philips self tapping screw**  
圓頭十字自攻螺絲(T1.5x4mm) x 3

**Countersunk philips self tapping screw**  
圓頭十字自攻螺絲  
T1.5x4mm

**Bearing**  
軸承  
 $\phi$  3.5x $\phi$  7x2.5mm

**Battery mounting plate**  
電池固定板

**Frame mounting bolt**  
機身鋁固定柱

**Socket button head self tapping screw**  
半圓頭內六角自攻螺絲  
T1.5x3mm

**Main shaft block**  
主軸固定座

**Carbon fiber upper frame**  
碳纖上側板  
110.49x42.6x1.2mm

**Battery mount**  
電池座

**Metal tail drive gear assembly**  
金屬尾傳動輪組

**Socket button head screw**  
半圓頭內六角螺絲  
0#x3mm

**Tail boom mount (Right)**  
尾管固定座(右)

**Tail drive gear mount(L)**  
尾傳動輪座(左)

**Drive belt**  
皮帶

**Socket button head self tapping screw**  
半圓頭內六角自攻螺絲  
T1.5x3mm

**Tail drive gear mount(R)**  
尾傳動輪座(右)

**Plastic hexagonal bolt**  
機身六角鋁柱  
2.2x14mm

**Socket button head screw**  
半圓頭內六角螺絲  
0#x3mm

**Tail boom mount (Left)**  
尾管固定座(左)

### Main frame assembly point:

First do not fully tighten the screws of main frames. Put the main shaft through the two bearings and check if the movements (up/down) are smooth. The bottom bracket must be firmly touched the level table top (glass surface); please keep the smooth movements on main shaft and level bottom bracket, then slowly tighten the screws. A correct assembly can help for the power and flight performance.

機身側板組立重點：  
側板螺絲先不完全鎖緊，放入主軸貫穿二顆軸承確認上下移動必需滑順，主體底板必須與水平桌面（玻璃平面）踏實緊貼；請保持主軸滑順與底板平行桌面後慢慢鎖緊螺絲。正確側板的組裝對動力與飛行性能有顯著幫助。

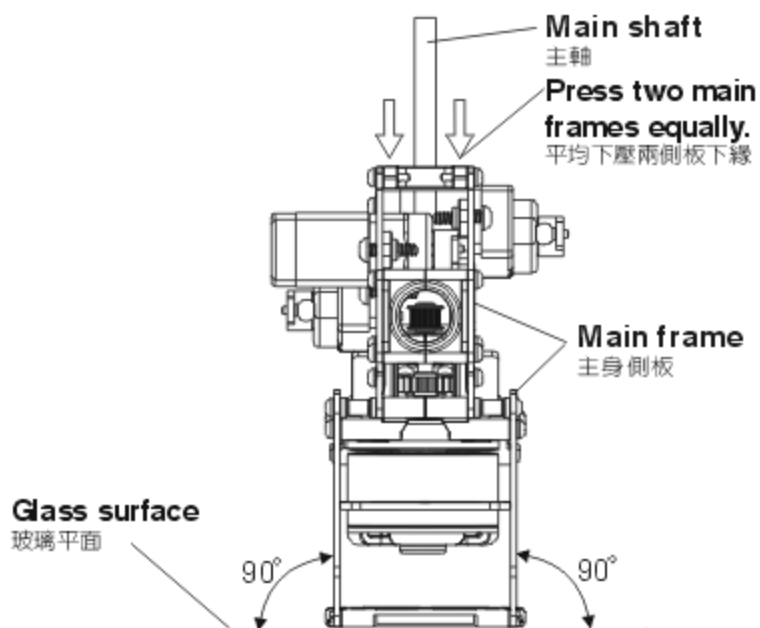

## 250HB3



**Socket button head self tapping screw**

半圓頭內六角自攻螺絲(T1.5x3mm) x 4



**Socket button head self tapping screw**

半圓頭內六角自攻螺絲(T1.5x4mm) x 2



**Socket button head screw**

半圓頭內六角螺絲(M2.5x5mm) x 2



**Aluminum link**

上下側板接合鋁柱  
( $\phi 1.5 \times \phi 3.2 \times 6 \text{ mm}$ ) x 2



**Socket button head screw**

半圓頭內六角螺絲(0#x4mm) x 6



**Socket button head screw**

半圓頭內六角螺絲(0#x10mm) x 2

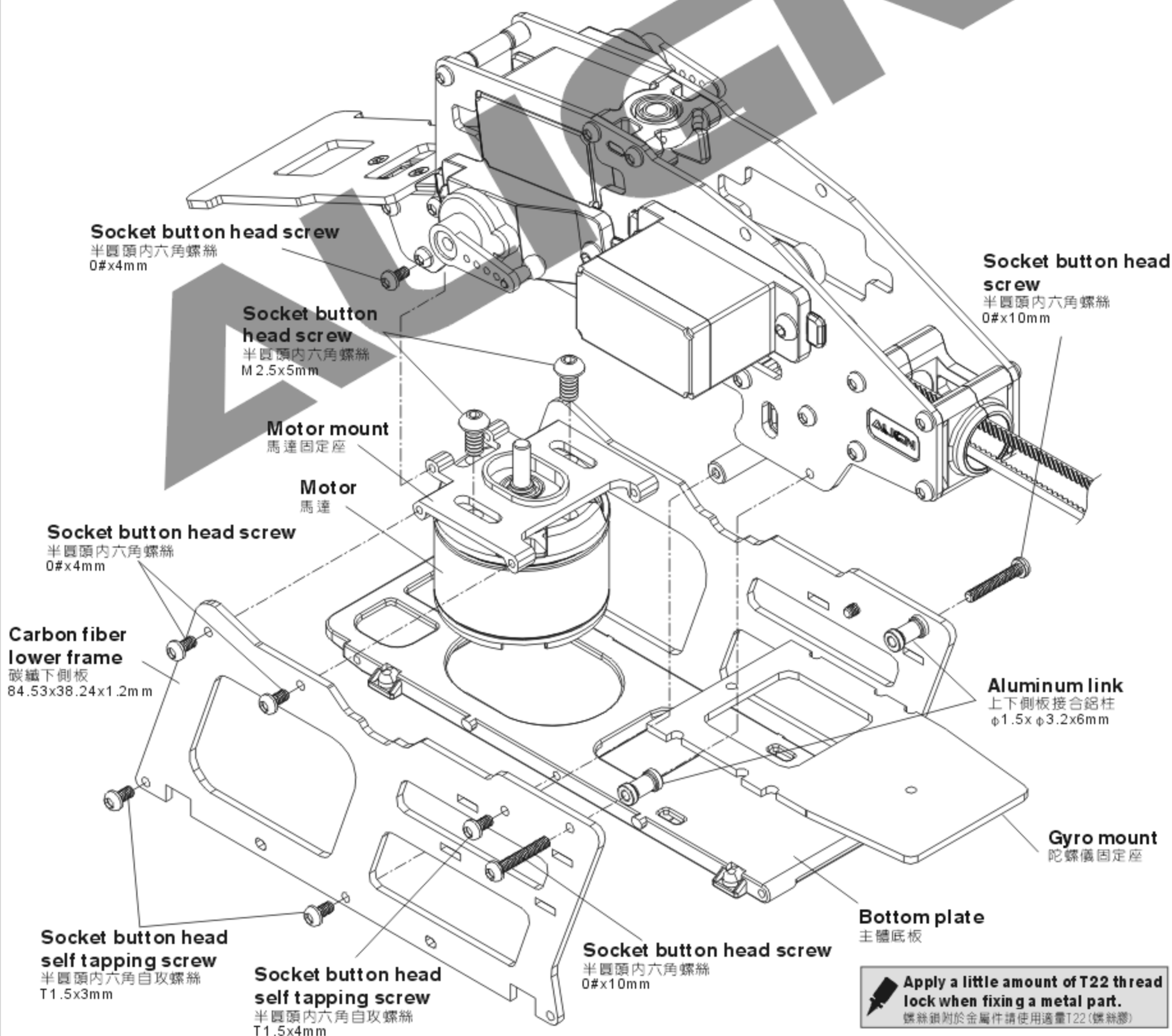

## 250HG 2A

 **Socket button head self tapping screw**  
半圓頭內六角自攻螺絲(T1.5x6mm) x 4

 **M2 Set screw**  
M2止洩螺絲(M2x2mm) x 4

**Option 另購：**

**DS410 Digital Servo:**

1. Stall torque/輸出扭力: 1.8kg.cm(4.8V)  
2.2kg.cm(6.0V)
2. Motion speed/動作速度: 0.13sec/60° (4.8V)  
0.09sec/60° (6.0V)
3. Dimension/尺寸: 22.8 x 12 x 25.4mm
4. Weight/重量: 12.7g

 **Apply a little amount of T22 thread lock when fixing a metal part.**  
螺絲鎖對於金屬件請使用適量T22(螺絲膠)

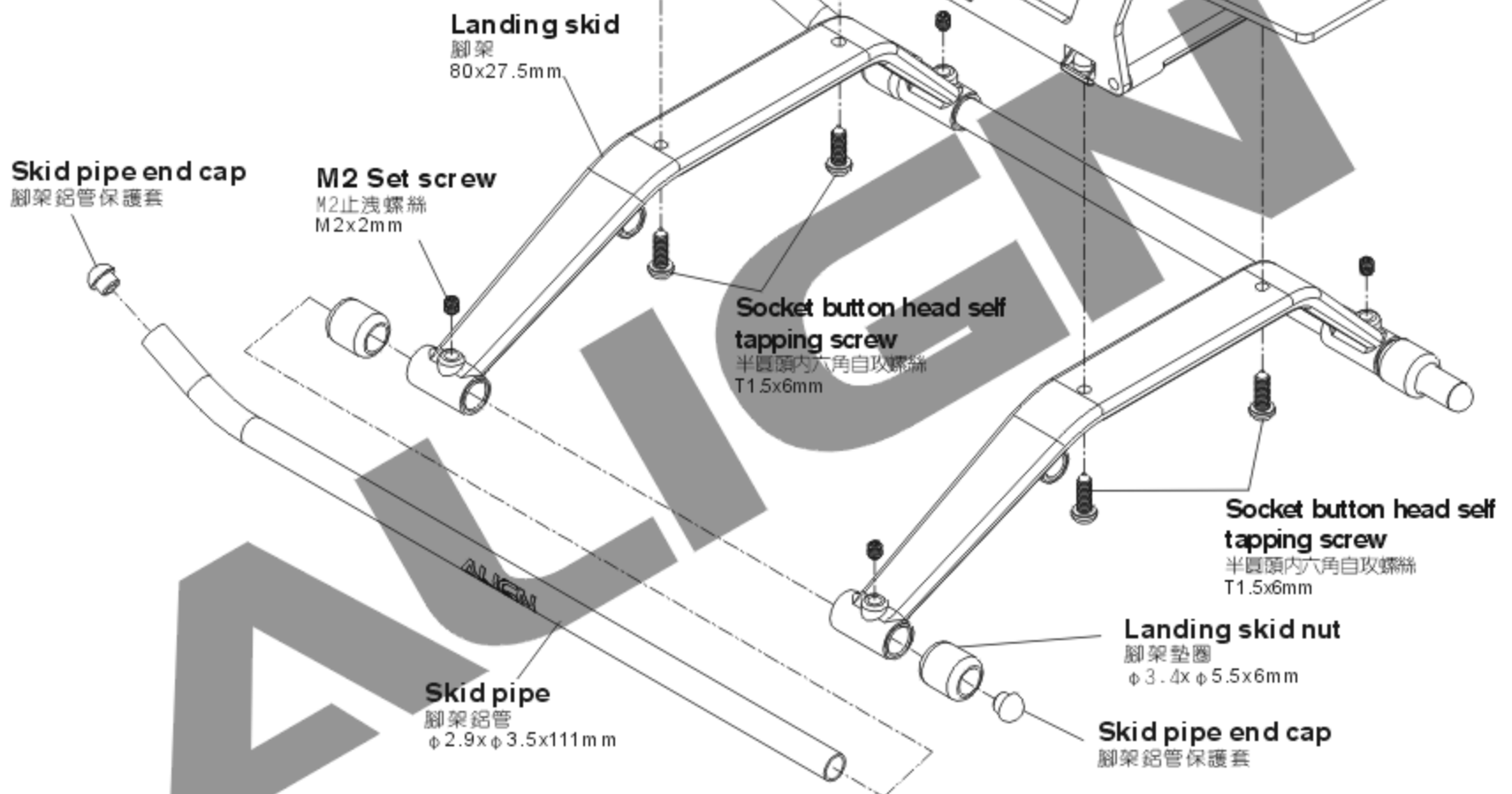
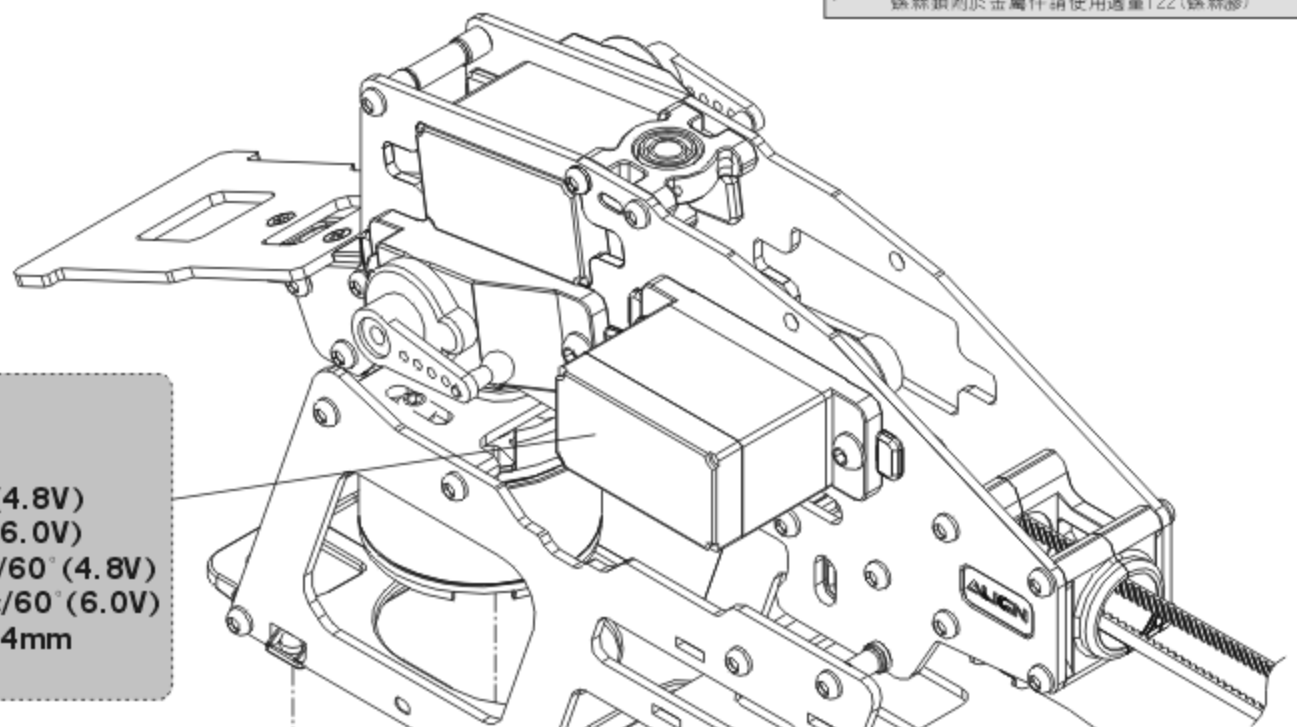

## 250HB2

 **Bearing**  
軸承(φ3xφ7x2mm) x 1

 **Countersunk philips self tapping screw**  
皿頭十字自攻螺絲  
(T1.5x4mm) x 4

**New main drive gear**  
新型主齒盤  
120T

**Words face down**  
字體請朝下

**Main gear case**  
主齒中心座

**Countersunk philips self tapping screw**  
皿頭十字自攻螺絲  
T1.5x4mm

**One-way bearing**  
單向軸承  
φ 3x φ 6.5x6mm

**Already assembled by factory, please note to check again.**  
已組裝完成，請務必自行再確認。

**Bearing**  
軸承  
φ3x φ7x2mm

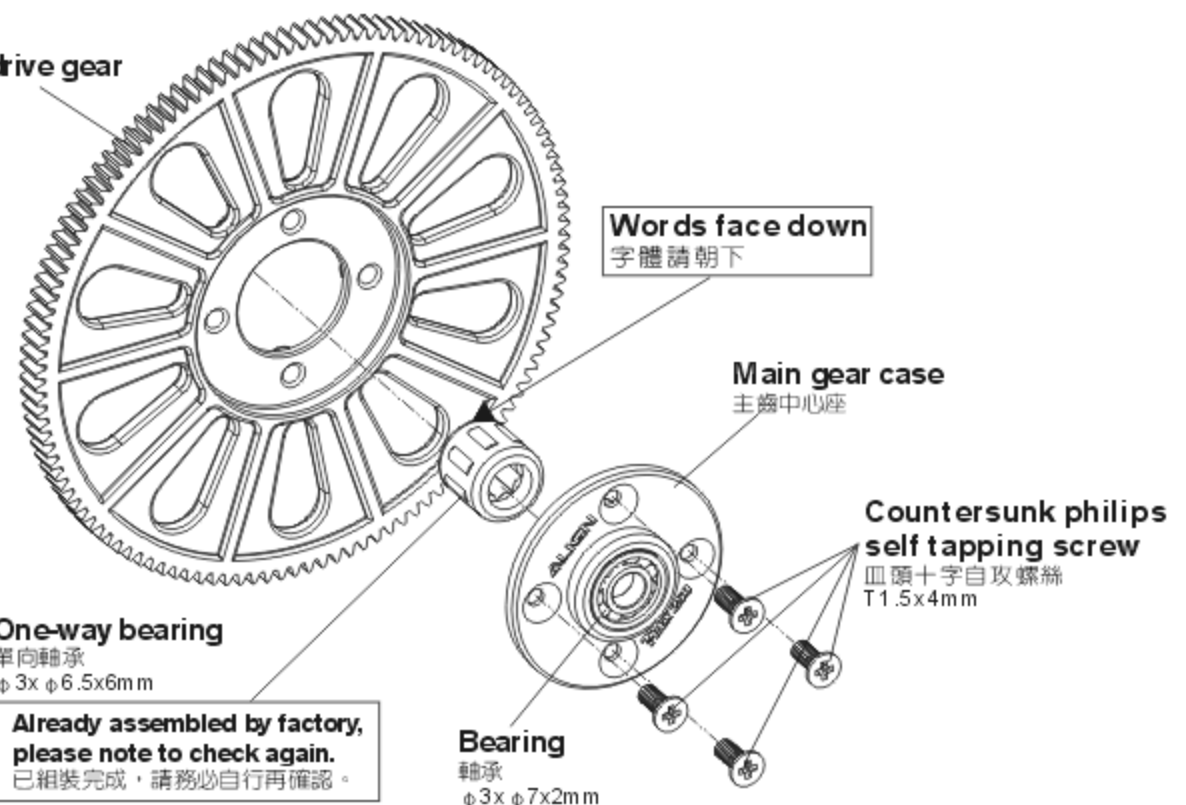

## 250HH8

**Socket screw**  
圓頭內六角螺絲(M2x8mm) x 2

## 250HZ4

**M2 Set screw**  
M2止洩螺絲(M2x6mm) x 2

## 250HH9

**Socket button head screw**  
半圓頭內六角螺絲(0#x4mm) x 1

**M2 Set screw**  
M2止洩螺絲(M2x2mm) x 1

## 250HZ4

**Washer**  
華司(φ1.5xφ5x0.3mm) x 1

Apply a little amount of T22 thread lock when fixing a metal part.  
螺絲鎖對於金屬件請使用適量T22(螺絲膠)

**Main blade**  
主旋翼

**Socket screw**  
圓頭內六角螺絲  
M2x8mm

**Linkage rod (D)**  
Approx. 38.5mm x 1  
連桿(D)約38.5mm x 1

**Linkage rod (E)**  
Approx. 26.5mm x 1  
連桿(E)約26.5mm x 1

**Linkage rod (F)**  
Approx. 28mm x 1  
連桿(F)約28mm x 1

**M2 Set screw**  
M2止洩螺絲  
M2x2mm

**Lock collar**  
主軸固定環  
φ3.5xφ6.5x2.8mm

**Anti rotation bracket**  
十字鎖導板

**Canopy mounting bolt**  
機頭罩固定柱

**M2 Set screw**  
M2止洩螺絲  
M2x6mm

**Spacer**  
單向墊片  
φ3xφ4.8x0.5mm

**New main drive gear**  
新型主齒輪組  
120T

**Washer**  
華司  
φ1.5xφ5x0.3mm

**Socket button head screw**  
半圓頭內六角螺絲  
0#x4mm

## 250HZ7

**250 Linkage rod (C)**  
250連桿(C) φ1.2x21mm x 2

**250 Linkage rod (D)**  
250連桿(D) φ1.2x32.5mm x 1

**Ball link**  
連桿頭 x 6



**CAUTION 注意**  
Please wait for at least 30 mins after gluing R48 on the motor pinion gear. You may start operating after the glue dried.  
馬達主齒上R48後請務必靜置30分鐘以上，待膠乾固後方可運轉。

**Set the motor pinion gear to main drive gear mesh to approximately 0.1mm to avoid excess power consumption or motor burnt due to overload.**

馬達前後可移動以保持兩齒輪咬合處約有0.1mm間隙，過緊齒咬合將造成動力損失或馬達高阻力的過載，嚴重可能造成馬達燒毀。

**Motor Pinion Gear 15T**  
15T馬達主齒

**Gear surface should be flush with tip of motor shaft.**  
齒輪面與馬達心軸平齊。

**Motor**  
馬達  
3400KV

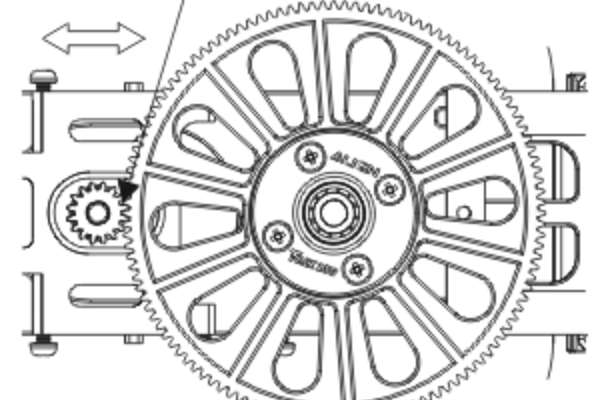

# 250HZ4



**Socket button head self tapping screw**

半圓頭內六角自攻螺絲(T1.5x6mm) x 2

**Socket button head self tapping screw**  
半圓頭內六角自攻螺絲  
T1.5x6mm

**Apply a little amount of T22 thread lock when fixing a metal part.**  
螺絲鎖對於金屬件請使用適量T22(螺絲膠)

**Tail control guide**  
尾控制桿固定環

**Rudder servo mount**  
尾伺服器固定座

**Tail boom**  
尾管  
φ 7.9xφ 8.5x241.7mm

# 250HT3

**CAUTION**  
注意

**Aim the opening of tail boom at the convex of the case and insert.**  
瞄準尾管上的凹槽和尾座凸出，並插入。

**Please insert the opening of tail boom into the convex.**  
尾管缺口方向裝入時，請導入導尾管座卡榫內。

**CAUTION**  
注意

**Drive belt illustration** 尾傳動皮帶裝配圖示

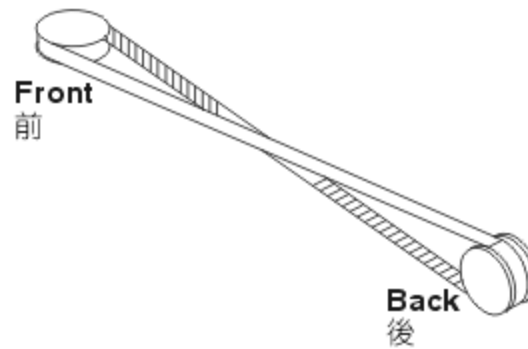

1. Check to rotate the belt 90° degrees when assembling.
2. Belt tension: Recommend to lightly tighten the drive belt after assembling tail boom to avoid vibration, belt friction and rotation slip.

1. 組裝時確認皮帶順轉90°
2. 皮帶緊度: 建議尾管組裝後皮帶請稍微拉緊，避免震動皮帶摩擦或轉動打滑。

Approx. 120mm  
約120mm

# 250HT5

Apply a little amount of T22 thread lock when fixing a metal part.  
螺絲鎖對於金屬件請使用適量T22(螺絲膠)

- Socket button head screw**  
半圓頭內六角螺絲(0#x3mm) x 6
- Bearing**  
軸承(φ2xφ5x2.5mm) x 2

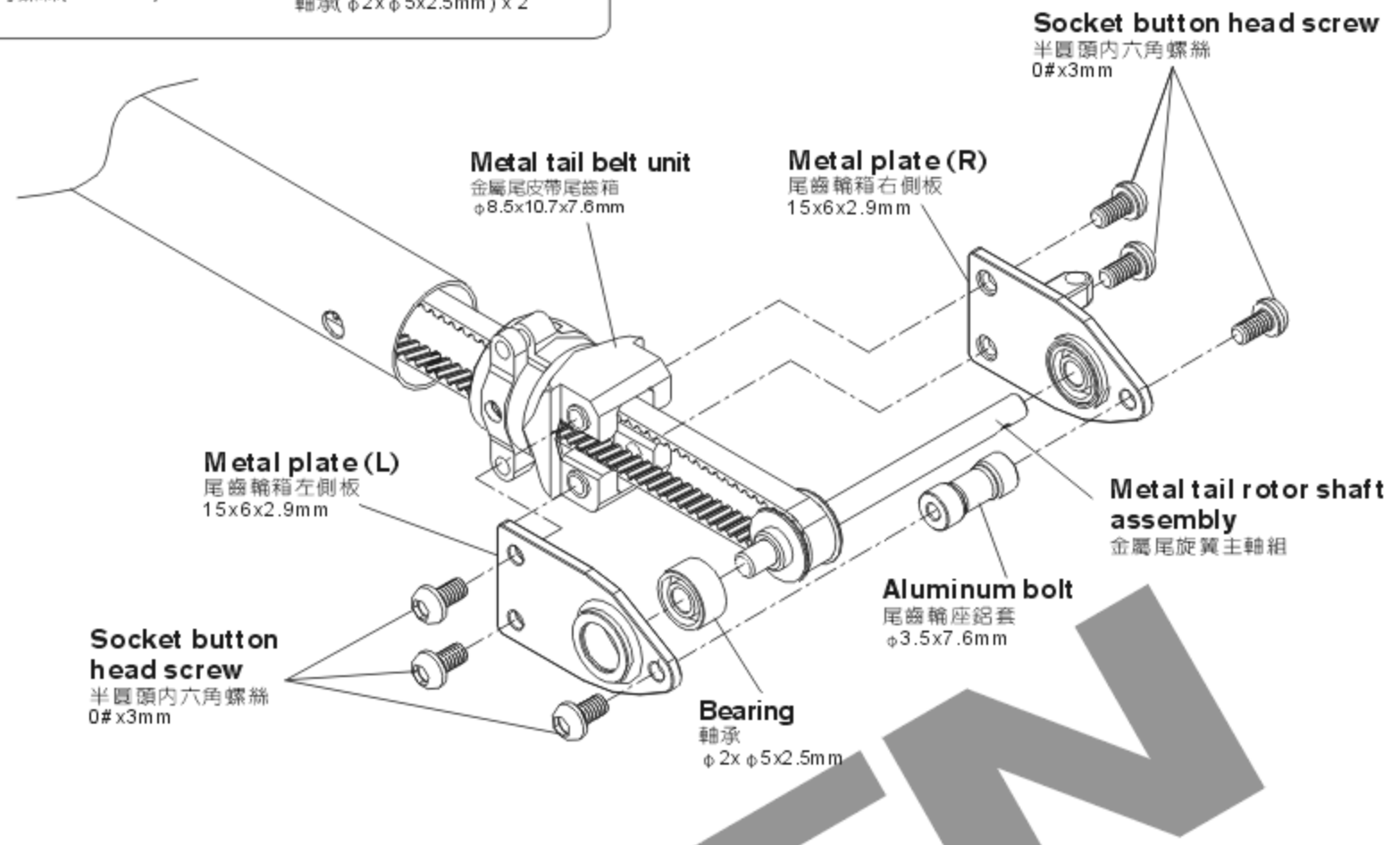

# 250HT5

- Socket button head screw**  
半圓頭內六角螺絲(0#x4mm) x 2
- Socket button head screw**  
半圓頭內六角螺絲(0#x5mm) x 2
- Socket button head screw**  
半圓頭內六角螺絲(0#x5mm) x 2
- Bearing**  
軸承(φ3xφ6x2.5mm) x 2
- Washer**  
華可(φ3xφ4.8x0.6mm) x 1
- Bearing**  
軸承(φ1.5xφ4x2mm) x 2
- Washer**  
尾夾座華可(φ1.5xφ3.8x0.7mm) x 2

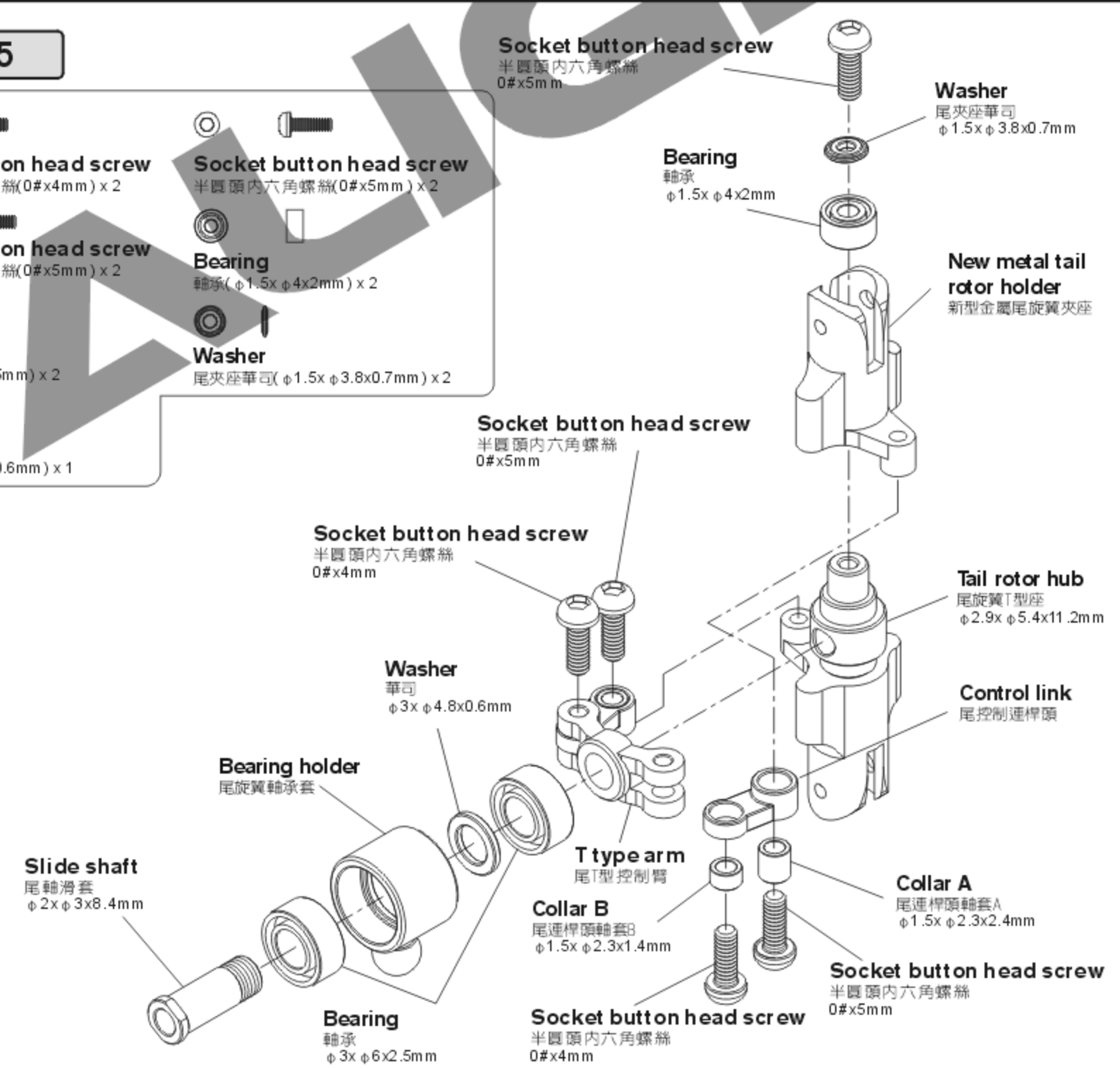

# 250HT5

   
**Socket button head screw**  
 半圓頭內六角螺絲(0#x6mm) x 2

   
**Socket button head screw**  
 半圓頭內六角螺絲(0#x8mm) x 1

   
**M2 Set screw**  
 M2止洩螺絲(M2x2mm) x 1

   
**Linkage ball A(0#x2)**  
 球頭A(0#x2)( $\phi$  3.5x5.3mm) x 1

   
**Washer**  
 華司( $\phi$  1.5x $\phi$  3x0.5mm) x 1

 **Apply a little amount of T22 thread lock when fixing a metal part.**  
 螺絲鎖於金屬件請使用適量T22(螺絲膠)

 **CAUTION**  
 注意

**When tightening a screw to a plastic part, please tighten it firmly, but not over tightened, or they will strip.**  
 螺絲鎖入塑膠件請務必注意，適當扭力鎖緊即可，而過緊的扭力可能會導致滑牙。

**For original manufactory package, if the product is already assembled by Factory, please check again if screws are firmly secured and applied with some glue.**  
 原廠零件出廠包裝如果是組裝品，請需再確認各螺絲是否鎖緊上膠。

 **CAUTION**  
 注意

**Aim tail rotor hub at the concave of tail rotor shaft and fix it, please apply a little glue on the set screw.**  
 尾旋翼T型座對準尾橫軸的凹刻並鎖上，請確認止洩螺絲上膠。

**Already assembled by factory, please note to check again.**  
 已組裝完成，請務必自行再確認。

**Tail pitch assembly**  
 尾旋翼控制組

**Tail blade**  
 尾旋翼

**Socket button head screw**  
 半圓頭內六角螺絲  
 0#x6mm

**M2 Set screw**  
 M2止洩螺絲  
 M2x2mm

**Tail rotor control arm**  
 尾旋翼控制臂

**Collar**  
 尾旋翼控制臂軸套  
 $\phi$  1.5x $\phi$  2.5x5mm

**Linkage ball A(0#x2)**  
 球頭A(0#x2)  
 $\phi$  3.5x5.3mm

**Washer**  
 華司  
 $\phi$  1.5x $\phi$  3x0.5mm

**Socket button head screw**  
 半圓頭內六角螺絲  
 0#x8mm

 **CAUTION**  
 注意

**When tightening a linkage ball to a plastic part, please note to use a little CA glue and tighten it firmly, but not over tightened, or they will strip.**  
 球頭鎖入塑膠件請務必注意，使用少量CA膠並適當扭力鎖緊即可，而過緊的扭力可能會導致滑牙。

**Care must be taken during assembly to ensure tail grips operate smoothly without binding. Any slight binding may affect tail action during flight.**  
 組裝時，確保尾夾座滑順，些微干涉將可能導致飛行時尾動作不順暢。

**Tail pitch assembly**  
 尾旋翼控制組

**Tail pitch bell crank must be parallel to tail output shaft to ensure sufficient pitch travel range.**  
 尾T型座與尾橫軸平齊以保持行程量足夠。



Apply a little amount of T22 thread lock when fixing a metal part.  
 螺絲鎖對於金屬件請使用適量T22(螺絲膠)

### 250HT5



**Socket button head screw**

半圓頭內六角螺絲(0#x5mm) x 1



**Socket button head screw**

半圓頭內六角螺絲(0#x8mm) x 1

### 250HZ4



**Socket button head self tapping screw**

半圓頭內六角自攻螺絲(T1.5x6mm) x 2

**Socket button head screw**  
 半圓頭內六角螺絲  
 0#x8mm

**3K CF Horizontal stabilizer**  
 3K碳纖水平翼

**Stabilizer mount (Upper)**  
 水平翼固定座(上)

**Socket button head self tapping screw**  
 半圓頭內六角自攻螺絲  
 T1.5x6mm

**Tail boom brace**  
 尾管支撐架組

**Stabilizer mount (Lower)**  
 水平翼固定座(下)

**Socket button head screw**  
 半圓頭內六角螺絲  
 0#x4mm

**Socket button head screw**  
 半圓頭內六角螺絲  
 0#x8mm

**Vertical stabilizer mount**  
 垂直翼固定座

**Socket button head screw**  
 半圓頭內六角螺絲  
 0#x5mm

**3K CF Vertical stabilizer**  
 3K碳纖垂直翼

### 250HT4



**Socket button head screw**

半圓頭內六角螺絲(0#x4mm) x 2



**Socket button head screw**

半圓頭內六角螺絲(0#x8mm) x 2

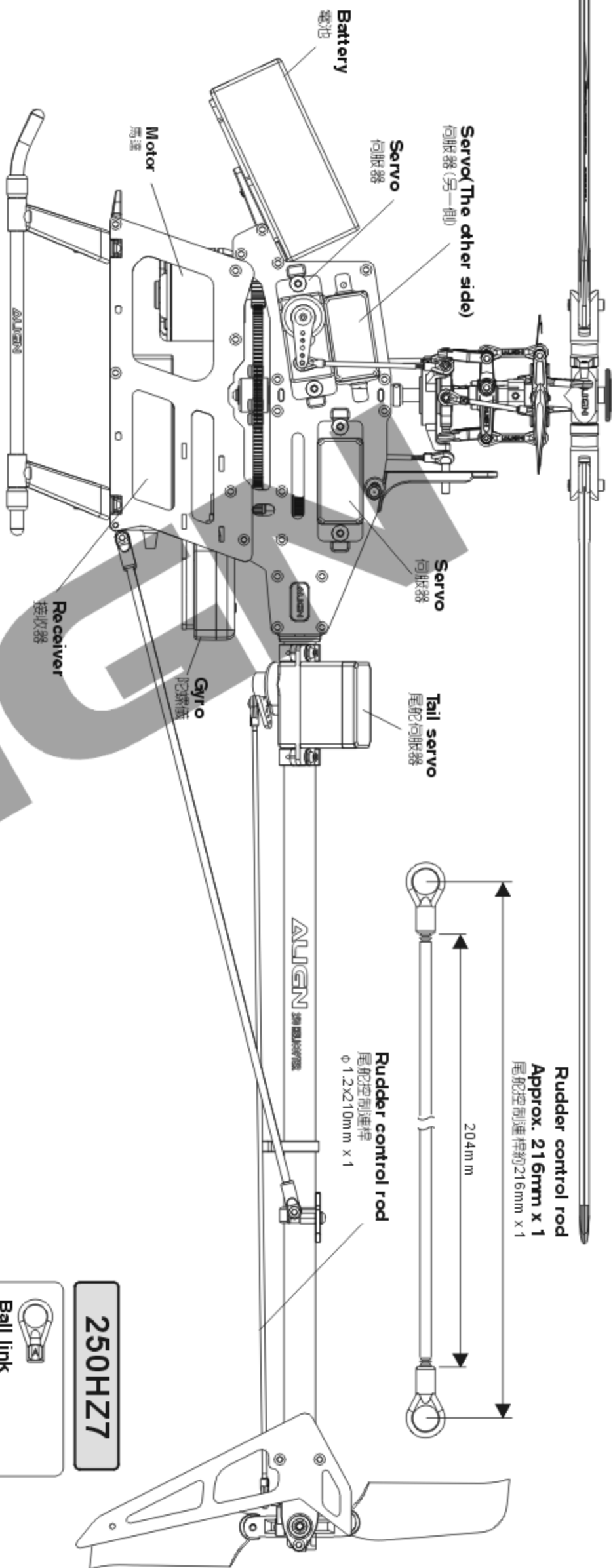

250HZ7

Ball link 連桿頭 x 2



250HC2

HITEC、FUTABA 6CH receiver wiring  
HITEC、FUTABA 6CH接收器接線示意圖

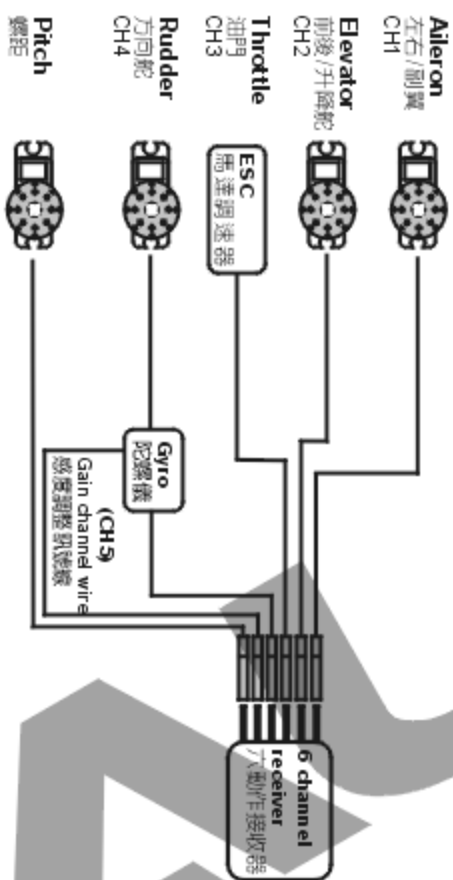

6-Channel Receiver is adequate for the requirements of T-REX helicopter. You will need the following channels at a minimum: Throttle, Rudder, Elevator, Aileron, and especially Pitch(CH6) and Gyro(CH5) controls. 六動作的接收器已足夠應付T-REX遙控直升機的遙控需求，除了油門、方向舵、升降舵、副翼等基本動作外，亦可以對應具備感應調整訊號線的陀螺儀(CH5)與螺距(CH6)。

JR 7CH receiver wiring  
JR 7CH接收器接線示意圖

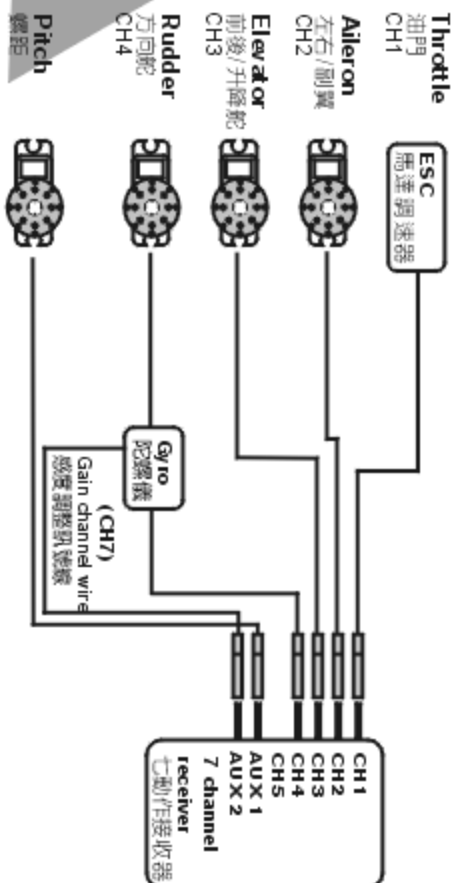

7-Channel Receiver is adequate for the requirements of T-REX helicopter. You will need the following channels at a minimum: Throttle, Rudder, Elevator, Aileron, and especially Pitch(AUX 1) and Gyro(AUX 2) controls. 七動作的接收器已足夠應付T-REX遙控直升機的遙控需求，除了油門、方向舵、升降舵、副翼等基本動作外，亦可以對應具備感應調整訊號線的陀螺儀(AUX 2)與螺距(AUX 1)。

## 7. GYRO INSTALLATION SUGGESTION 陀螺儀安裝建議位置

ALIGN

### Installation Method (1) 安裝方式(1)

Use attached Hoop and Loop Tape, tape the Hoop side (hooked) on the battery mounting plate and the Loop side (fuzzy) on the battery to fix the battery in order to prevent any slip.

以附贈的魔术沾膠帶，將公端的魔术沾(勾狀)黏貼於電池座上，母端的魔术沾(纖毛狀)黏貼於電池上，可有效固定電池避免滑動。

Hook and Loop Tape (fuzzy)  
魔术沾母端

Hook and Loop Tape (hooked)  
魔术沾公端

**NOTE: When installing the speed controller, please keep a distance at least 1 cm from the receiver to avoid any interference.**

注意: 安裝ESC時請與接收器保持至少1cm以上的距離，避免干擾接收器。

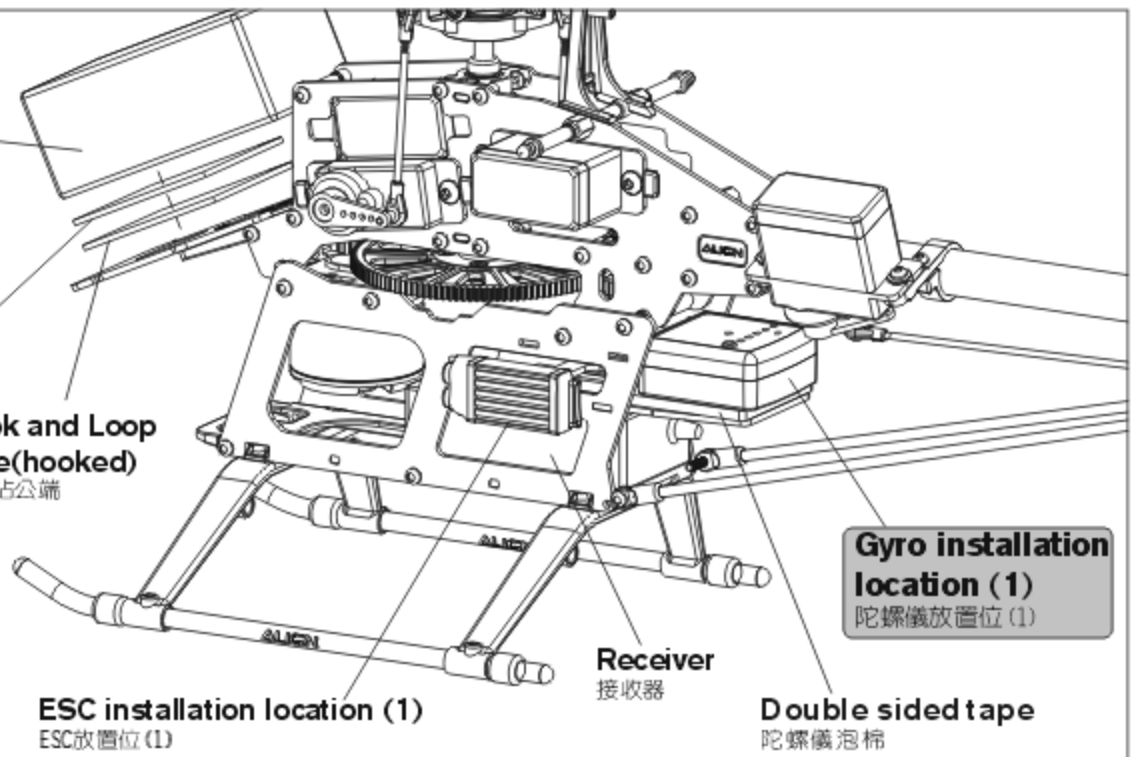

### Installation Method (2) 安裝方式(2)

**NOTE: When installing the speed controller, please keep a distance at least 1 cm from the receiver to avoid any interference.**

注意: 安裝ESC時請與接收器保持至少1cm以上的距離，避免干擾接收器。

Double sided tape  
陀螺儀泡棉

Gyro installation location (2)  
陀螺儀放置位(2)

ESC installation location (2)  
ESC放置位(2)

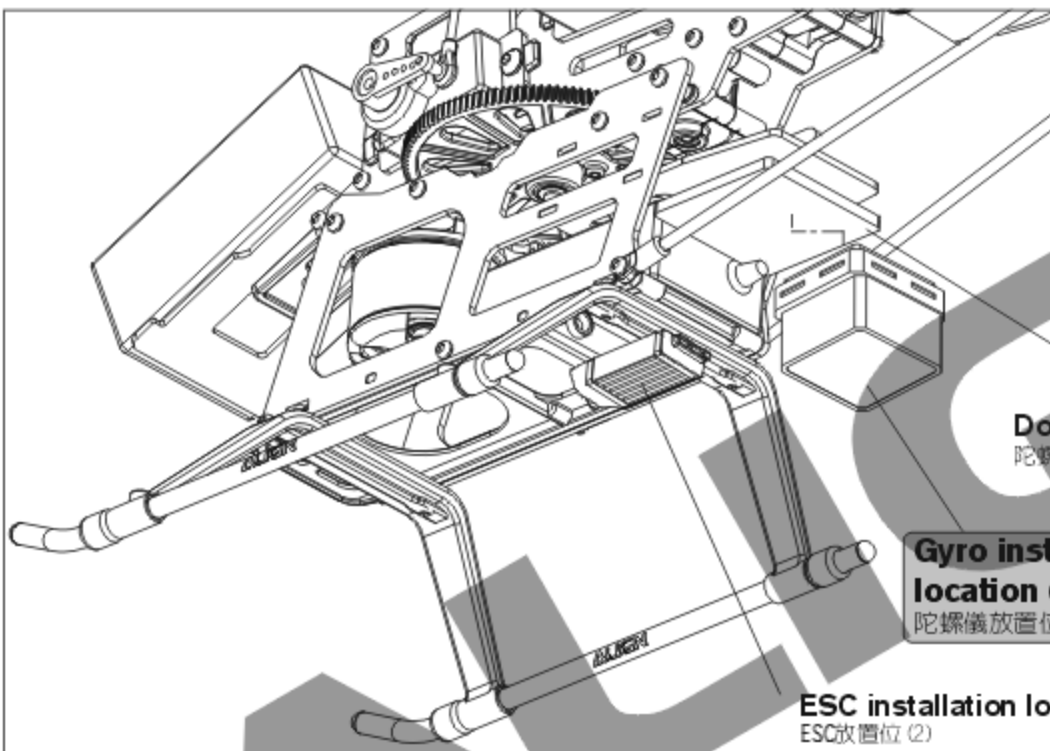

## 8. Dial Pitch Gauge Pad Instruction 可調式螺距規墊塊使用說明

ALIGN

Dial Pitch Gauge Pad  
可調式螺距規墊塊

ALIGN Dial Pitch Gauge

旋轉式螺距規  
料號: K10391A-1

Optional  
選購

Dial Pitch Gauge Pad  
可調式螺距規墊塊

Resewed for the use of  
ALIGN dial pitch gauge  
pad.  
亞拓旋轉式螺距規專用

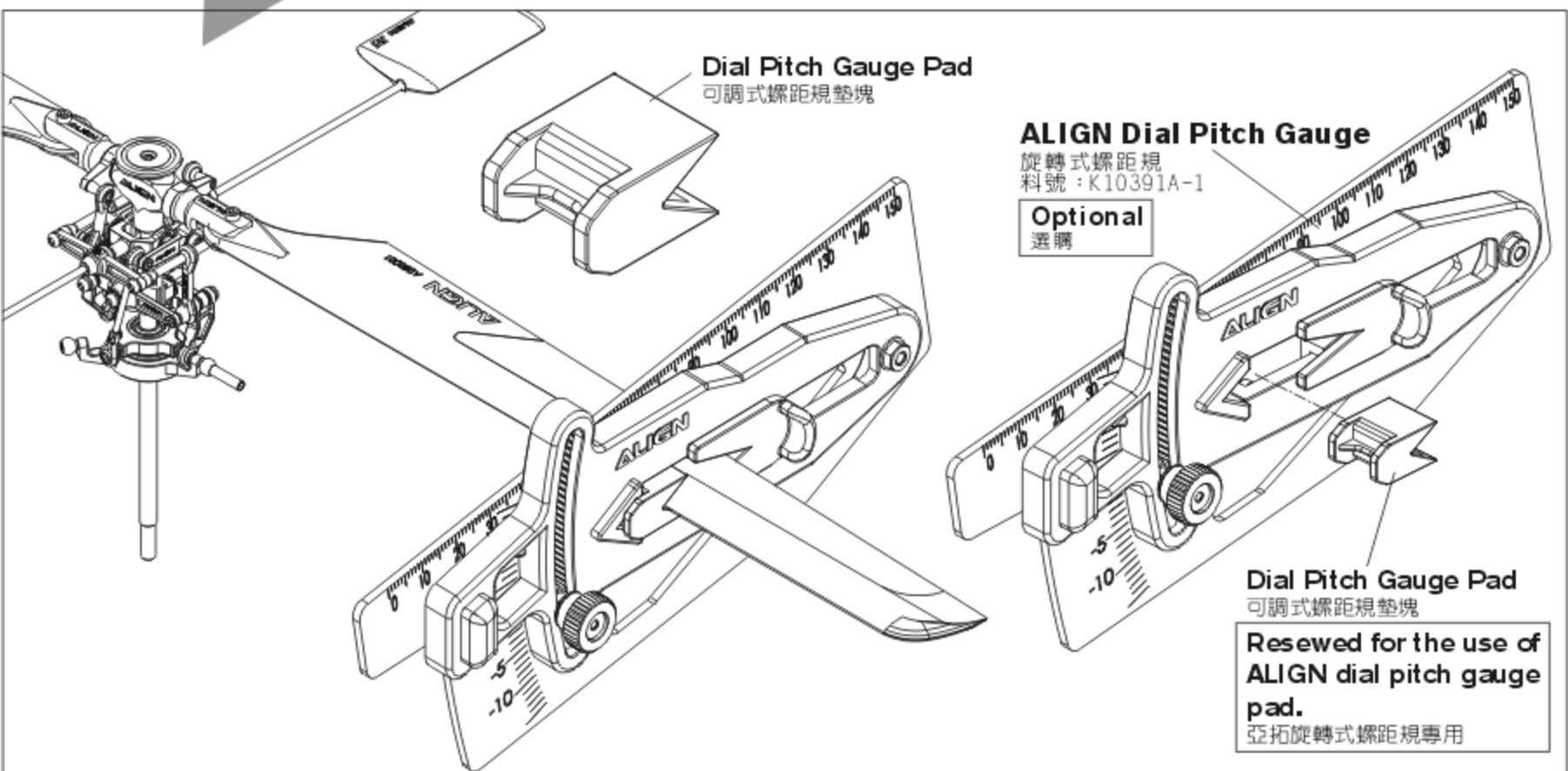

To set this option is to turn on the transmitter and connect to the helicopter power. **Note: For the safety, please do not connect ESC to the brushless motor before the setting in order to prevent any accident caused by the motor running during the setting.**  
 此項設定只要開啓發射器，接上直昇機電源即可進行操作。注意：為了安全起見，設定前請先不要將無刷調速器與無刷馬達的三條線接上，以免調整時啓動馬達而發生危險。

### JR Transmitter/Servo JR遙控器對應伺服器關係

Pitch:CH6 螺距:CH6  
Aileron:CH2 副翼:CH2

Aileron:CH2 副翼:CH2  
Pitch:CH6 螺距:CH6

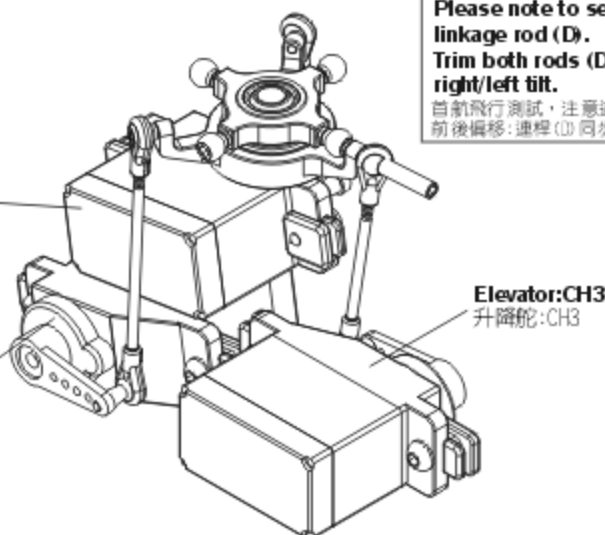

Please note to set the subtrim neutral for the first trial flight. If the helicopter wags, please trim linkage rod (D).  
 Trim both rods (D) simultaneously to adjust for forward/backward tilt. Trim rod (D) separately for right/left tilt.

首航飛行測試，注意遙控器微調均設定中立點，若發現飛行時，機身前後左右偏移，請先調整連桿(D)前後偏移：連桿(D)同步調整；左右偏移：連桿(D)單獨調整為標準。

Positions of CH2 · CH6 are exchangeable, After assembling as photo (Note: Set the transmitter under CCPM 120 degrees mode), pull throttle stick (pitch) upward. If one swashplate servo (or two servos) moves downward, adjust reverse switch (REV) on the transmitter to make it moves upward. If three servo move downward, adjust the travel value (+) of SWASH CH6 on the transmitter to make them move upward. When the actions of Aileron and Elevator are opposite, adjust travel values of SWASH CH2 and CH3.

CH2、CH6可互換配置，依舊連結後(注意：遙控器須設定於CCPM 120°十字盤模式)，將油門搖桿(Pitch)往上推，若十字盤伺服器有1個或2個往下移時，請調整遙控器的反轉開關(REV)使伺服器往上，若3個伺服器同時往下移時，請調整遙控器 SWASH CH6 行程量的正負值，使伺服器同時往上移，副翼與前後動作相反時，同樣調整 SWASH CH2、CH3 行程量正負值。

### FUTABA/HITEC Transmitter/Servo FUTABA/HITEC遙控器對應伺服器關係

Pitch:CH6 螺距:CH6  
Aileron:CH1 副翼:CH1

Aileron:CH1 副翼:CH1  
Pitch:CH6 螺距:CH6

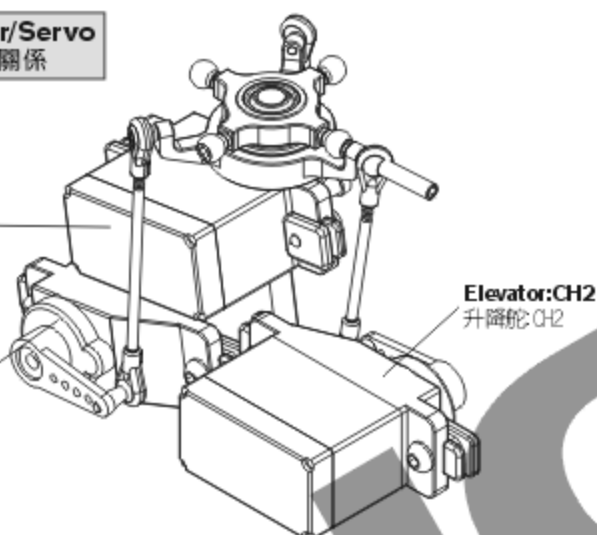

Positions of CH1 · CH6 are exchangeable, After assembling as photo (Note: Set the transmitter under CCPM 120 degrees mode), pull throttle stick (pitch) upward. If one swashplate servo (or two servos) moves downward, adjust reverse switch (REV) on the transmitter to make it moves upward. If three servo move downward, adjust the travel value (+) of SWASH CH6 on the transmitter to make them move upward. When the actions of Aileron and Elevator are opposite, adjust travel values of SWASH CH1 and CH2.

CH1、CH6可互換配置，依舊連結後(注意：遙控器須設定於CCPM 120°十字盤模式)，將油門搖桿(Pitch)往上推，若十字盤伺服器有1個或2個往下移時，請調整遙控器的反轉開關(REV)使伺服器往上，若3個伺服器同時往下移時，請調整遙控器 SWASH CH6 行程量的正負值，使伺服器同時往上移，副翼與前後動作相反時，同樣調整 SWASH CH1、CH2 行程量正負值。

# 10.ADJUSTMENTS FOR GYRO AND TAIL NEUTRAL SETTING 陀螺儀與尾翼中立點設定調整

Recommend to choose Head Lock type for Gyro and turn off Revolution mixing(RVMX) mode on the transmitter, then set the gain switch on the transmitter and the gyro to Head lock mode. The gain setting is about 70%, and after transmitter setting, connect to the helicopter power for working on tail neutral setting. **Note: When connecting to the helicopter power, please do not touch tail rudder stick and the helicopter. Then wait for 3 seconds, make tail servo horn and tail servo at a right angle(90 degrees), tail pitch assembly must be correctly fixed about in the middle of the travel of tail rotor shaft for standard neutral setting.**

陀螺儀選擇，建議選用鎖定式陀螺儀，且發射器內陀螺儀設定請關閉根轉混控模式，並將發射器上的感度開關與陀螺儀切至鎖定模式，感度設約 70% 左右，發射器設定完成後接上直昇機電源，即可進行尾中立點設置。注意：當接上直昇機電源時請勿撥動尾舵搖桿或碰觸機體，待3秒陀螺儀鎖定後尾伺服器需與尾伺服器約成 90°，尾旋翼控制組須正確置於尾橫軸行程約中間位置，即為標準尾中立點設定。

### TAIL NEUTRAL SETTING 尾中立點設定

After setting Head Lock mode, correct setting position of tail servo and tail pitch assembly is as photo. If the tail pitch assembly is not in the middle position, please adjust the length of rudder control rod to trim.

陀螺儀鎖定後尾伺服器與尾 Pitch控制組正確擺置位置。若尾 Pitch控制組未置中時請調整尾控制連桿的長度來修正。

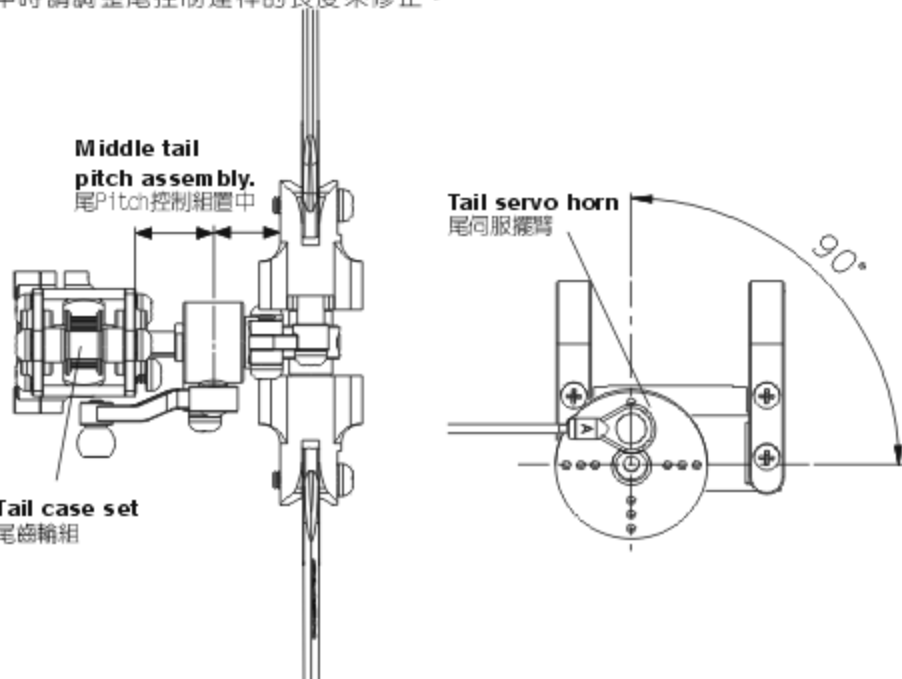

### HEAD LOCK DIRECTION SETTING OF GYRO 陀螺儀鎖定方向設定

To check the head lock direction of gyro is to move the tail counterclockwise and the tail servo horn will be trimmed clockwise. If it trims in the reverse direction, please switch the gyro to "REVERSE".

陀螺儀鎖定方向確認，當手搖尾部反時鐘擺動，尾伺服器應順時鐘修正，反向時請切換陀螺儀上「鎖定反向」開關修正。

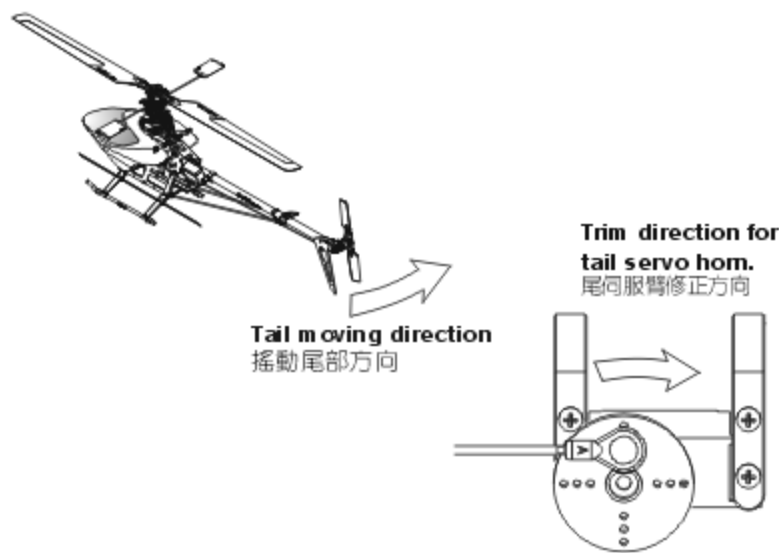

**BATTERY電池：ALIGN Li-Poly 11.1V 850 mAh**

Motor Pinion Gear 馬達主齒	Main Rotor Blade 主旋翼規格	Pitch 螺距	Current(A) approx. 電流(A)大約值	Throttle Curve 油門曲線	RPM approx. 主旋翼轉速大約值	
15T	205 Main Blades 205主旋翼	Hover 停懸	+5°	3.9	0/50/70/85/100%	3520
		Idle	0°	4.2	85%中	4460
			0°	4.9	100/100/100/100/100%	4700 ⚠
			±11°	10.4		4160
	205D Carbon Fiber Blades 205D主旋翼	Hover 停懸	+5°	3.8	0/50/70/85/100%	3530
		Idle	0°	4.0	85%中	4500
			0°	4.7	100/100/100/100/100%	4770 ⚠
			±11°	10.1		4200

NOTE: 1. Please use a pitch gauge to adjust the pitch value. Incorrect excess pitch setting will result poor helicopter performance and reduce ESC's life and battery's life.

⚠ 2. For the safeties of flight and helicopter structure, please do not equip the power of main blade over 4500RPM.

註：1. 請務必使用螺距規來量測調整螺距，不正確的過大螺距設定不但無法發揮直昇機的特性，反會影響到無刷調速器與電池的壽命。

⚠ 2. 為了飛行安全與機體結構安全，主旋翼轉速設定禁止超過4500RPM。

13.RCE-BL15X BRUSHLESS SPEED CONTROLLER INSTRUCTION MANUAL 無刷調速器使用說明

**PRODUCT FEATURES 產品特色**

1. 5-6V step-less adjustable BEC output allowing custom voltage setting to match servo specification.
2. BEC output utilizing linear power system, suitable for 7.4-11.1V (2S-3S) Li battery, with continuous current rating of 2A, and burst rating of 3A.
3. Three programmable throttle speed settings to support quick throttle response.
4. Include soft start and Governor Mode.
5. Small and compact PCB design for lightweight and simple installation.
6. Large heat sink for optimum thermal performance.
7. Highly compatible to work with 98% of all brushless motors currently on the market.
8. Ultra-smooth motor start designed to run with all kinds of brushless motors.
9. The power inlet utilizes a Japanese made "Low ESR" capacitor in order to provide stable power source.
10. The throttle has more than 200 step resolution that provides great throttle response and control.

1. 5-6伏特無段可調式BEC輸出，可依伺服器規格與所需的特性自行設定電壓。
2. BEC輸入端採用線性電源設計，適用7.4-11.1V(2S-3S)鋰電，持續耐電流2A，瞬間3A。
3. 三段可程式油門反應速度，使動力的反應隨傳隨到。
4. 具緩啟動及Governor Mode定速功能。
5. 體積小，窄型設計，安裝於機身容易。
6. 有散熱片設計，可延長電變壽命。
7. 超高相容性，可對應市面上 98% 無碳刷馬達。
8. 絕佳起步設計，無論國產、進口、內轉、外轉無刷馬達皆起步順暢。
9. 電池電源端採用日製 Low ESR 低阻抗電解電容，大幅提高電源之穩定性。
10. 油門達 200 段以上解析度，無格數之油門感覺。

**WIRING ILLUSTRATION 接線示意圖**

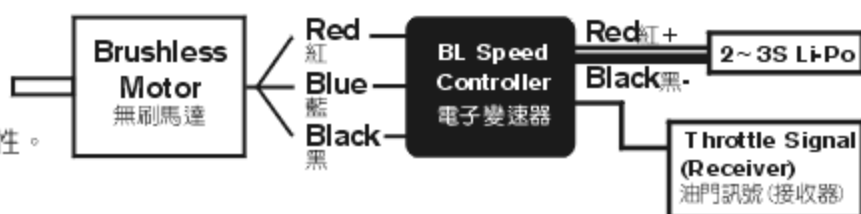

**SPECIFICATION 規格**

Model 型號	Continuous Current 持續	Peak Current 瞬間	BEC Output BEC輸出	Dimension 尺寸	Weight 重量
RCE-BL15X	15A	20A	Output voltage: 5-6V step-less adjustment Continuous current 2A; Burst current 3A 輸出電壓: 5-6V無段可調式 承受電流: 持續2A、瞬間3A	42x24x9.3mm	15g

1. Good temperature situation for working at the maximum current
  2. Supporting motor types: 2 ~ 10 pole in/outrunner brushless motors.
  3. Supporting maximum RPM: 2 pole → 190,000 rpm ; 6 pole → 63,000 rpm.
  4. Input voltage: 5.5V ~ 12.6V(2~ 3S Li-Po)
- NOTE: When setting to the Quick throttle response speed, the accelerative peak current will increase.

1. 持續最大電流需在機體散熱良好情況下。
  2. 支援馬達型式: 二極至十數極之內外轉子無碳刷馬達。
  3. 支援最高轉速: 二極→190,000rpm; 六極→63,000rpm。
  4. 輸入電壓: 5.5V-12.6V(2-3s Li-Po)
- 注意: 設定為高油門反應速度時，加速瞬間電流會有增大情形。

## FUNCTIONS 產品功能

1. Brake Option - 3 settings that include Brake disabled/Soft brake/Hard brake.
2. Electronic Timing Option - 3 settings that include Low timing/Mid timing/High timing. Generally, 2 pole motors are recommended to use low timing, while 6 or more poles should use Mid timing. High timing gives more power at the expense of efficiency. Always check the current draw after changing the timing in order to prevent overloading of battery.
3. Battery Protection Option- 2 settings that include Li-ion, Li-poly High/Middle cutoff voltage protection.

The default setting is high cutoff voltage protection. CPU will automatically determine cell number of input Lithium battery (2S~3S). This option will prevent over-discharge of the battery. The following reference is the guideline for setting the Battery Protection option.

**3-1 Li-ion/Li-poly High cutoff voltage protection-**When the voltage of single cell drops to 3.2V, the first step of battery protection mode will be engaged by the ESC resulting in reduced power. The pilot should reduce the throttle and prepare landing. If the voltage of single cell drops to 3.0V, the second step of battery protection mode will be engaged resulting in power cutoff. (\*Note 1) For 11.1V/3cells Lithium battery, the full charged voltage will be approximately 12.6V.

According to this input voltage, CPU will determine that this is a 3cell battery.

First step protection:  $3.2V \times 3\text{cell} = 9.6V$

Second step protection:  $3.0V \times 3\text{cell} = 9.0V$

When the voltage drops to 9.6V, the power will be reduced. When the voltage drops to 9.0V, the power will be cut off.

**3-2 Li-ion/Li-poly Middle cutoff voltage protection-** This option is same as instruction 3-1, but when the voltage of single cell drops to 3.0V, the first step of battery protection will be engaged. When the voltage of single cell drops to 2.8V, the second step of battery protection will be engaged. (\*Note 1)

Note 1: Second step of battery protection only works when Aircraft mode is setting to the option 4-1.

NOTE: THIS OPTION IS ONLY SUITABLE FOR A FULLY CHARGED BATTERY PACK IN GOOD WORKING CONDITION.

4. Aircraft Option: 3 settings that include Normal Airplane / Helicopter 1 / Helicopter 2.  
Normal Airplane Mode is used for general airplanes and gliders. When flying Helicopters, you can choose Helicopter 1 Mode, or Helicopter 2 Mode. Helicopter 1 Mode provides Soft Start feature. Helicopter 2 Mode provides Soft Start and Governor Mode.
5. Throttle response speed: 3 settings that include standard/ Medium/ Quick throttle response speed.  
The default setting is "quick speed". Use this option to adjust the setting according to flight character. For example, setting at Medium or Quick speed for 3D and powerful flight to make the power response more quickly, but note the accelerative peak current and power expense will increase.
6. BEC output voltage setting: 5-6V step-less adjustment.

This option allows custom voltage setting. Default setting is 5.5V; please adjust the voltage according to the specification of the servo (speed and resistance). Prior to entering the setup mode, a voltmeter needs to be connected to the power inlet of the receiver (as illustration) to monitor the selected voltage. The voltage is set by varying the throttle stick position from low (5V) to high (6V).

The voltmeter needs to be connected to any un-use inlets "+" and "-" to measure the selected voltage.

將電壓表連接到任一未使用通道的 "+" 端及 "-" 端，以量測所選擇的電壓。

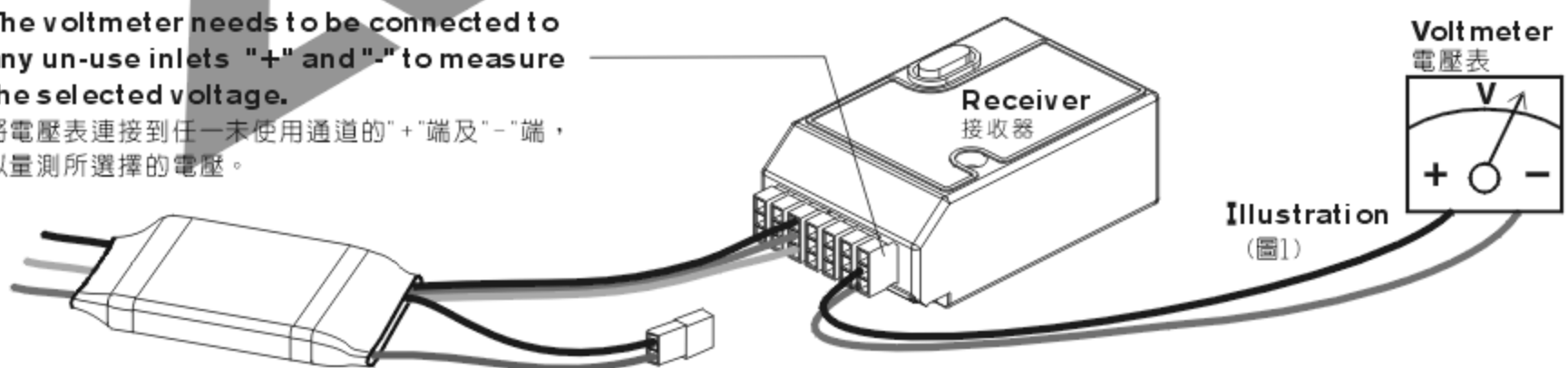

NOTE: Certain servos are designed to work with high voltage, while other servos are designed for lower voltage. To avoid damage to servos, please follow the servo's factory specification to determine the proper voltage setting.

注意: 部份伺服器不適合較高的電壓下操作，請依原廠適用電壓規格設定，避免造成伺服器燒毀。

7. Thermal Protection: When the ESC temperature reaches 80°C for any reason, it will engage the battery protection circuit, reducing power to the ESC. We recommend mounting the ESC in a location with adequate air flow and ventilation.
8. Safe Power On Alarm: When the operator turns on the ESC, it will automatically detect the transmitter signal. The ESC will emit a confirmation tone and enter normal operation mode if the throttle is set to the lowest position. If the throttle position is at full throttle, it will begin to enter Setup Mode. If the throttle is in any other position, the ESC will emit an alarm and not enter into user mode for safety precautions.
9. Aircraft Locator: If the aircraft should land or crash in an unexpected location and become lost, the pilot can enable the Aircraft Locator Option. The Aircraft Locator Option is engaged by turning off the transmitter. When the ESC does not receive a signal from the transmitter for 30 seconds, it will start to send an alarm to the motor. The sound of the alarm will aid the pilot to locate the aircraft. This option will not work with a PCM receiver that has SAVE function enabled, or with low noise resistant PPM receivers.

1. 煞車設定:三段選擇分為無煞車 / 軟性煞車 / 急煞車
2. 進角設定:三段選擇分為低進角 / 中進角 / 高進角  
設定時機分為二極以及六極以上無碳刷馬達，二極無碳刷馬達一般適用低進角，若希望馬達轉速提高，可將進角設定為中進角。六極以上無碳刷馬達一般適用中進角，若希望馬達轉速提高，可將進角設定為高進角。然而進角之調整需要注意電流之變化，避免電池過載，影響電池及馬達壽命。
3. 電池保護電壓設定:二段選擇分為 Li-Ion、Li-Po 高截止電壓保護/中截止電壓保護出廠設定為高截止電壓保護：此功能會自動判定所輸入鋰電池的cell數(2-3S)，並提供使用者對該電池之放電保護，以避免因放電電壓過低而造成電池損壞，以下為設定值之解說：  
3-1 Li-Ion/Li-Po高截止電壓保護：當鋰電單cell壓降達3.2V時，電變會啟動第一階段保護，使動力間歇性中斷，此時使用者應將油門收小，準備降落；而當單cell電壓持續壓降達到3.0V時則會啟動第二階段保護，完全限制動力輸出(註1:僅在4-1選項“一般飛機模式”下才會啟動第二階段保護)。  
例：以一個使用11.1V 3cell鋰電池之系統而言11.1V鋰電池充飽電壓約12.6V，此輸入電壓CPU會自動判定為3cell鋰電。  
第一階段保護:3.2Vx3cell=9.6V 第二階段保護:3.0Vx3cell=9.0V  
當電壓降至9.6V時，動力會間歇性中斷，當壓降達到9.0V時則完全限制動力輸出。  
3-2 Li-Ion/Li-Po中截止電壓保護:同3-1功能說明，但單cell壓降達到3.0V時，會啟動第一階段保護，單cell壓降達到2.8V時啟動第二階段保護(註1)。  
注意:以上功能僅適用於充電電，且功能正常的鋰電池。
4. 飛機模式設定:三段式選擇分為:一般飛機模式/直昇機模式1/直昇機模式2  
使用於一般飛機或滑翔機時，請設定於一般飛機模式，使用於直昇機時可選擇直昇機模式1:具有緩啟動功能，或直昇機模式2:具有緩啟動及Governor Mode定速功能。
5. 油門反應速度設定:三段選擇分為標準/中速/快速  
出廠設定值為“快速”油門反應速度，此功能提供使用者依所需的飛行特性來作適當的調整，例如3D飛機與劇烈的3D直昇機飛行時可設定為中速或快速，使動力反應更加快速、靈敏，但須注意提高油門反應速度時，加速瞬間電流與耗電量會有增大的情形。
6. BEC輸出電壓設定:5-6V無段調整  
本功能提供使用者自行設定BEC輸出電壓，初始電壓為5.5V，使用者可依伺服器的規格與所需的特性(速度與扭力)自行更改設定；進入此項設定前，請先將電壓表連接到接收器的電源端(如圖1)，用以監看所選擇的電壓，設定時以油門搖桿的位置來決定輸出電壓，油門搖桿最低為5伏特，最高為6伏特，之間的電壓值可移動搖桿的位置任意設定。
7. 溫度保護:當電變因不良之空氣對流或是過載輸出導致溫度上升達80°C時，電變會啟動溫度保護，而使動力間歇性中斷，建議將電變裝置在機艙內空氣對流之位置，並實際使用電流量表測輸出電流，以達到電變之最佳效率。
8. 開機防暴衝提醒功能:當使用者開啓電變電源時，系統會自動偵測發射機之設定，如果發射機油門未置於最低點，或未置於最高點準備進入設定模式，馬達將不會轉動，同時會有警示警響提醒。
9. 尋機功能:當飛機降若再長草區無法以目視定位時，使用者可將發射機關閉，當電變無法接收來自接收機信號時，電變會於30秒後使馬達發出警示警響，以利定位。此功能不適用於設定了 SAVE 功能之 PCM 接收機，或抗雜訊低之 PPM 接收機。

## SETUP MODE 設定模式

1. Setup mode: Make sure to connect the ESC to the throttle channel of the receiver. Please refer to the user manual of your radio system. The second step is to connect the 3 power-out signal pins to the brushless motor. Before you turn on the transmitter, please adjust the throttle stick to the maximum full throttle position. Proceed to connect the battery to the ESC. You will hear confirmation sounds as soon as you enter the SETUP MODE. Please refer the attached flow chart for details.
  2. Throttle stick positions in Setup mode: Setup mode includes six settings: Brake, Electronic Timing, Battery Protection, Aircraft, Throttle Response Speed and BEC output voltage. Every setting has three options. Simply place the throttle stick in the highest, middle, and lowest positions for each setting. For example, first brake setting (Hard): move the stick to the highest position. Then timing setting (mid): move the throttle stick in the middle position.
1. 進入設定模式:將電變與接收器之油門 Channel 連接，不同之遙控系統請參閱您遙控系統之使用手冊，馬達之三條線亦與電變連接，將發射器之油門搖桿推到最高點，使之於全油門狀態，先開啓發射器電源，再將電源連接至電變，進入設定模式後，馬達將有設定模式之提示警響。請參考第二頁程式化設定模式說明。
  2. 設定模式中之動作:設定模式共含有六項設定，分別為煞車、馬達進角、電池保護、飛機模式、油門反應速度級 BEC 輸出電壓等設定，詳細內容請參考產品功能之解說。每一項設定中各含三段設定，各項設定以油門搖桿之上、中、下位置來決定其設定值。  
例如:煞車設定時，油門搖桿撥至最高，則設定為急煞車，進入第二項進角設定時，油門搖桿撥至中間，則設定為中進角。

Mode 設定模式	Throttle position 油門搖桿	Low 低	Middle 中	High 高
Brake 煞車設定		● Brake disabled(1-1) 無煞車(1-1)	Soft brake(1-2) 軟性煞車(1-2)	Hard brake(1-3) 急煞車(1-3)
Electronic Timing 進角設定		Low-timing(2-1) 低進角(2-1)	● Mid-timing(2-2) 中進角(2-2)	High-timing(2-3) 高進角(2-3)
Battery Protection 電池保護電壓設定		● High cutoff voltage protection(3-1) 高截止電壓保護(3-1)	Middle cutoff voltage protection(3-2) 中截止電壓保護(3-2)	—
Aircraft 飛機模式設定		Normal Airplane/Glider(4-1) 一般飛機 / 滑翔機(4-1)	● Helicopter 1 (Soft Start)(4-2) 直昇機模式1(緩啟動功能)(4-2)	Helicopter 2 (Soft Start+ Governor Mode)(4-3) 直昇機模式2(緩啟動+Governor Mode定速功能)(4-3)
Throttle response speed 油門反應速度設定		Standard(5-1) 標準(5-1)	Medium speed(5-2) 中速(5-2)	● Quick speed(5-3) 快速(5-3)
BEC output voltage BEC輸出電壓設定		5.0V	● 5.5V	6.0V

Note: “●” default setting  
註: “●” 表示出廠設定值

Chart A  
表A





## SETUP MODE 程式化設定模式

Minimum 4 channel radio is required 四動以上標準發射器均可執行設定

**1**  
Place the throttle stick to the highest position.  
Switch on transmitter.  
打開電源，油門搖桿置於最高點  
準備進入程式化功能設定模式



**2**  
Connect battery to ESC  
變速器接上電源，馬達響音提示

♪♪♪ Power on sound  
開機確認音  
♪♪♪ Enter Setup Mode  
進入設定模式

**3**  
Throttle channel adjustment process, the highest position acknowledge sound.  
油門校正程序最高點應答音

**4**  
Place the throttle stick to the lowest position, the lowest position acknowledge sound.  
油門搖桿撥到最低點確認響音

**5**  
Use throttle stick to set preferred Brake Mode within the 5 tones.  
A confirmation sound will kick in when finish.

於5音節之音樂響音時以發射器油門搖桿設定，設定值請參考表A煞車設定，結束時將有連續響音確認



**6**  
Use throttle stick to set preferred Timing Mode within the 5 tones. (Refer to Chart A)  
A confirmation sound will kick in when finish.

於5音節之音樂響音時以發射器油門搖桿設定，設定值請參考表A進角設定，結束時將有連續響音確認



**7**  
Use throttle stick to set preferred Battery Protection Mode within the 5 tones. (Refer to Chart A)  
A confirmation sound will kick in when finish.

於5音節之音樂響音時以發射器油門搖桿設定，設定值請參考表A電池保護電壓設定，結束時將有連續響音確認



**8**  
Use throttle stick to set preferred Aircraft Mode within the 5 tones. (Refer to Chart A)  
A confirmation sound will kick in when finish.

於5音節之音樂響音時以發射器油門搖桿設定，設定值請參考表A飛機模式設定，結束時將有連續響音確認



**9**  
Use throttle stick to set preferred Throttle Response Speed Mode within the 5 tones. (Refer to Chart A)  
A confirmation sound will kick in when finish.

於5音節之音樂響音時以發射器油門搖桿設定，設定值請參考表A油門反應速度設定，結束時將有連續響音確認



**10**  
Use throttle stick to set preferred BEC Output Voltage Mode within 5 tones. (Refer to Chart A)  
A confirmation sound will kick in when finish.

於5音節之音樂響音時以發射器油門搖桿設定，設定值請參考表ABEC輸出電壓設定，結束時將有連續響音確認



**PLEASE PRACTICE SIMULATION FLIGHT BEFORE REAL FLYING 飛行前請事先熟練模擬飛行**

**Do a simulation flight until you familiarize your fingers with the movements of the rudders, and keep practicing until the fingers move naturally.**

1. Place the helicopter in a clear open field ( Make sure the power OFF ) and the tail of helicopter point to yourself.
2. Practice to operate the throttle stick (as below illustration) and repeat practicing "Throttle high/low", "Aileron left/right", "Rudder left/right", and "Elevator up/down".
3. The simulation flight practice is very important, please keep practicing until the fingers move naturally when you hear operation orders being call out.
4. Another safe and effective practice method is to use the transmitter flying on the computer through simulator software sold on the market.

在還沒瞭解直昇機各動作的操控方式前，嚴禁通電飛行，請先進行模擬飛行的練習，並不斷的重複，直到手指可熟練的控制各個動作及方向。

1. 將直昇機放在空曠的地方(確認電源為關閉)，並將直昇機的機尾對準自己。
2. 練習操作遙控器的各搖桿(各動作的操作方式如下圖)，並反覆練習油門高/低、副翼左/右、升降舵前/後及方向舵左/右操作方式。
3. 模擬飛行的練習相當重要，請重複練習直到不需思索，手指能自然隨著喊出的指令移動控制。
4. 另外一種最有效、最安全的練習方式，就是透過市面販售的模擬軟體，以遙控器在電腦上模擬飛行，熟悉各種方向的操控。



Mode 1	Mode 2	Illustration 圖示
<p><b>Aileron 副翼</b></p>		<p>Move left 左移</p> <p>Move right 右移</p> <p>Rotate left 左翻</p> <p>Rotate right 右翻</p>
<p><b>Elevator 升降/前後</b></p>		<p>Fly forward 前進</p> <p>Fly backward 後退</p> <p>Forward rotate 前翻</p> <p>backward rotate 後翻</p>
<p><b>Throttle 油門</b></p>		<p>Ascent 上升</p> <p>Descent 下降</p>
<p><b>Rudder 方向</b></p>		<p>Turn right 右旋</p> <p>Turn left 左旋</p>

## FLIGHT ADJUSTMENT AND NOTICE FOR BEGINNERS 初學飛行調整與注意



- ⊙ Check if the screws are firmly tightened.
- ⊙ Check if the transmitter and receivers are fully charged.
- ⊙ 再次確認→螺絲是否鎖固?
- ⊙ 發射器和接收器電池是否足夠。

- ★ When arriving at the flying field.
- ★ 當抵達飛行場



If there are other radio control aircraft at the field, make sure to check their frequencies and tell them what frequency you are using. Frequency interference can cause your model, or other models to crash and increase the risk of danger. 假使飛行場有其他遙控飛機，請確認他們的頻率，並告知他們你正在使用的頻率，相同的頻率會造成干擾導致失控和大大地增加風險。

## STARTING AND STOPPING THE MOTOR 啟動和停止馬達

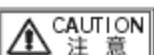

First check to make sure no one else is operating on the same frequency. Then place the throttle stick at lowest position and turn on the transmitter.

首先確認附近沒有其他相同頻率的使用，然後打開發射器將油門搖桿推到低點。

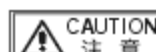

Check if the throttle stick is set at the lowest position. 確認油門搖桿是在最低的位置。

- ★ Check the movement.
- ★ 動作確認



**ON! Step 1**  
First turn on the transmitter.  
先開啓發射器

- ⊙ Are the rudders moving according to the controls?
- ⊙ Follow the transmitter's instruction manual to do a range test.
- ⊙ 方向舵是否隨著控制方向移動?
- ⊙ 根據發射器說明書進行距離測試。

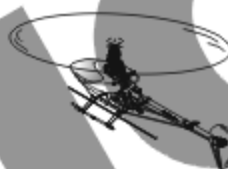

**ON! Step 2**  
Connect to the helicopter power  
接上直昇機電源



**OFF! Step 3**  
Reverse the above orders to turn off.  
關閉電源時請依上述操作動作反執行。

## Main rotor adjustments 主旋翼雙槳平衡調整



Tracking adjustment is very dangerous, so please keep away from the helicopter at a distance of at least 5m. 調整軌跡非常危險，請於距離飛機最少5公尺的距離。

1. Before adjusting, apply a red piece of tape on one blade, or paint a red stripe with a marker or paint to identify on blade.
2. Raise the throttle stick slowly and stop just before the helicopter lifts-off ground. Look at the spinning blades from the side of the helicopter.
3. Look at the path of the rotor carefully. If the two blades rotate in the same path, it does not need to adjustment. If one blade is higher or lower than the other blade, adjust the tracking immediately.
4. Linkage rod (C): Slight pitch trim.

1. 調整前先在其中一支主旋翼的翼端，貼上有顏色的貼紙或畫上顏色記號，方便雙槳調整辨識。
2. 慢慢的推起油門搖桿到高點並且停止，在飛機離開地面前，從飛機側邊觀察主旋翼轉動。
3. 仔細觀察旋翼軌跡(假如兩支旋翼移動都是相同軌跡，則不需要調整;可是如果一支旋翼較高或較低產生“雙槳”的情形時，則必須立刻調整軌跡)。
4. 連桿(C)為螺距微調調整。

- A.** When rotating, the blade with higher path means the pitch too big. Please shorten pitch linkage rod (C) for regular trim.  
**B.** When rotating, the blade with lower path means the pitch too small. Please lengthen pitch linkage rod (C) for regular trim.
- A. 旋翼轉動時較高軌跡的主旋翼表示螺距(PITCH)過大，請調短連桿(C)修正。  
B. 旋翼轉動時較低軌跡的主旋翼表示螺距(PITCH)過小，請調長連桿(C)修正。



Incorrect tracking may cause vibrations. Please repeat adjusting the tracking to make sure the rotor is correctly aligned. After tracking adjustment, please check the pitch angle is approx. +5~6° when hovering.

不正確的旋翼軌跡會導致震動，請不斷重複調整軌跡，使旋翼軌跡精準正確。在調整軌跡後，確認一下Pitch角度在停旋時應為大約+5-6°。

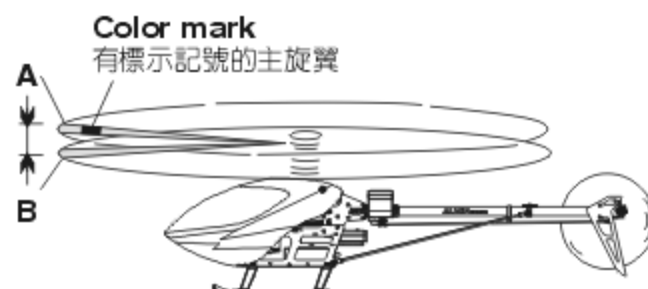

## FLIGHT ADJUSTMENT AND NOTICE FOR BEGINNERS 初學飛行調整與注意



- ◎ Make sure that no one or obstructions in the vicinity.
- ◎ You must first practice hovering for flying safety.  
This is a basic flight action. (Hovering means keeping the helicopter in mid air in a fixed position)
- ◎ 確認鄰近地區沒有人和障礙物。
- ◎ 為了飛行安全，你必須先練習停旋，這是飛行動作的基礎（停旋：直昇機滯留空中並保持固定位置）。

- ◎ Please stand approximately 5m diagonally behind the helicopter.
- ◎ 練習時，請站在直昇機後方5公尺。

- ◎ Beginner may install a training landing gear to avoid any crash caused by offset effect while landing.  
必要時初學者可以在腳架下方安裝練習架，可避免降落時因重心偏移導致主旋翼或直昇機損毀。



## STEP 1 THROTTLE CONTROL PRACTICE 油門控制練習

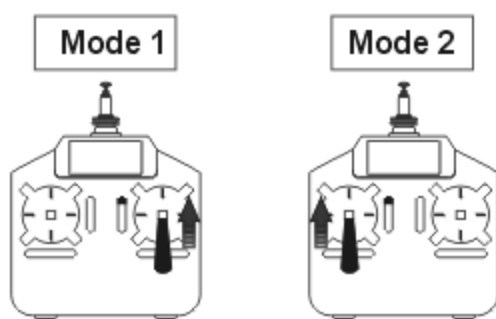

- ◎ When the helicopter begins to lift-off the ground, slowly reduce the throttle to bring the helicopter back down. Keep practicing this action until you control the throttle smoothly.
- ◎ 當直昇機開始離地時，慢慢降低油門將飛機降下。持續練習飛機從地面上升和下降直到你覺得油門控制很順。

## STEP 2 AILERON AND ELEVATOR CONTROL PRACTICE 副翼和升降控制練習

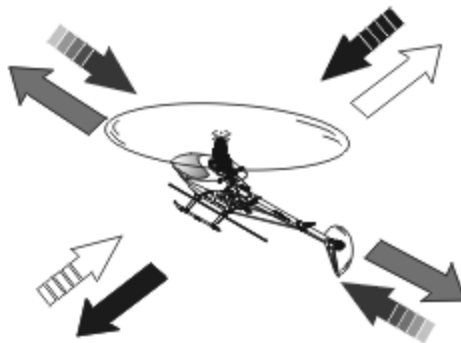
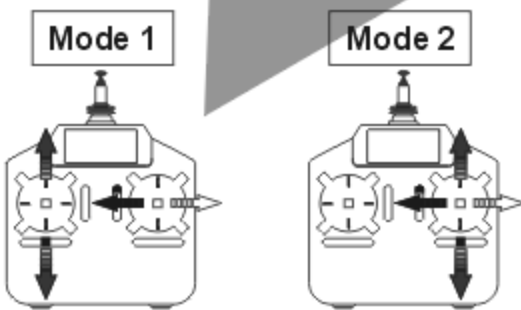

1. Raise the throttle stick slowly.
  2. Move the helicopter in any direction back, forward, left and right, slowly move the aileron and elevator sticks in the opposite direction to fly back to its original position.
1. 慢慢升起油門搖桿。
  2. 使直昇機依指示：移動向後/向前/向左/向右，慢慢的反向移動副翼和升降搖桿並將直昇機開回到原來位置。



- ◎ If the nose of the helicopter moves, please lower the throttle stick and land the helicopter. Then move your position diagonally behind the helicopter 5m and continue practicing.
- ◎ If the helicopter flies too far away from you, please land the helicopter and move your position behind 5m and continue practicing.
- ◎ 當直昇機機頭偏移時，請降低油門並且降落，然後移動自己的位置到直昇機的正後方5公尺再繼續練習。
- ◎ 假如直昇機飛離你太遠，請先降落直昇機，並到直昇機後5公尺再繼續練習。

### STEP 3 RUDDER CONTROL PRACTICING 方向舵操作練習

1. Slowly raise the throttle stick.
2. Move the nose of the helicopter to right or left, and then slowly move the rudder stick in the opposite direction to fly back to its original position.

1. 慢慢升起油門搖桿。
2. 將直昇機機頭移動左或右，然後慢慢反向移動方向舵搖桿並將直昇機飛回原本位置。

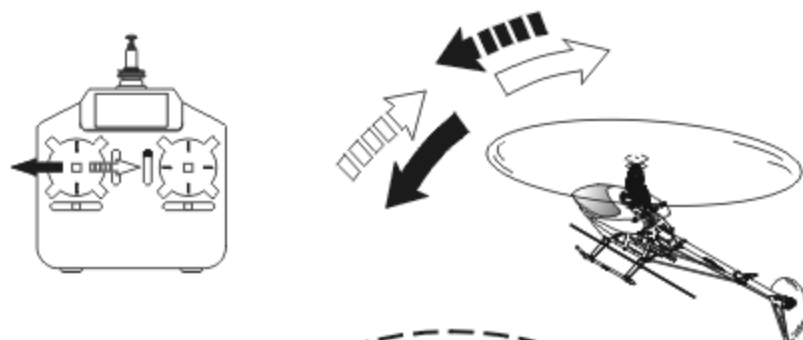

### STEP 4

After you are familiar with all actions from Step1 to 3, draw a circle on the ground and practice within the circle to increase your accuracy.

當你覺得 step1-3 動作熟悉了，在地上畫圈圈並在這個圈圈的範圍內練習飛行，以增加你操控的準確度。

- ◎ You can draw a smaller circle when you get more familiar with the actions.
- ◎ 當你更加習慣操作動作，你可以畫更小的圈圈。



### STEP 5 DIRECTION CHANGE AND HOVERING PRACTICE 改變直昇機方向和練習停旋

After you are familiar with Step1 to 4, stand at side of the helicopter and continue practicing Step1 to 4. Then repeat the Step1 to 4 by standing right in front of the helicopter.

當你覺得step1-4動作熟悉了，站在面對直昇機側邊並繼續練習step1-4。之後，站在直昇機機頭右邊重複步驟練習。

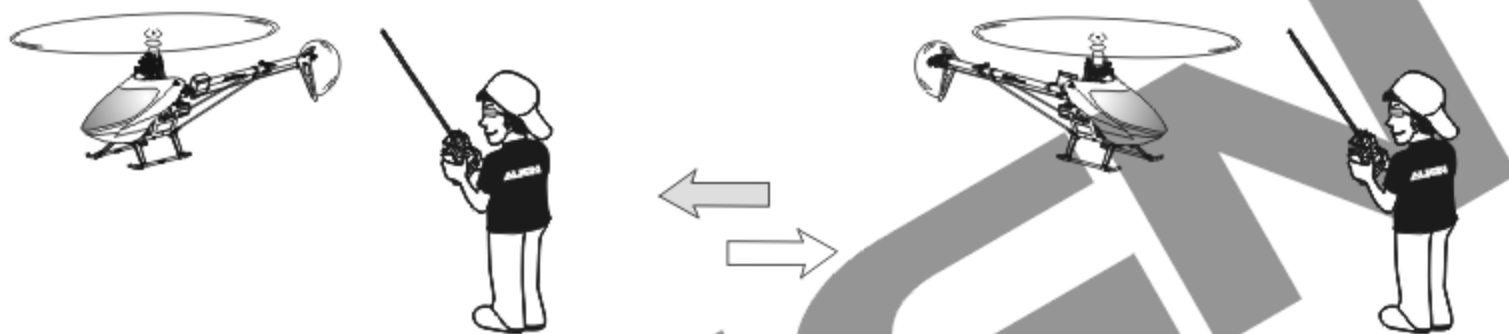

### ADJUSTMENT OF EACH TRIM 飛行動作微調

Slowly raise the throttle stick and just as the helicopter lift-off the ground, you can use the trim to correct the action if the helicopter leans in a different direction.

慢慢升起油門搖桿，當直昇機剛剛離開地面時，若直昇機傾向不同方向，可使用微調修正動作。

#### 1. Adjustment of rudder trim 調整方向舵微調

Just before the helicopter lift-off, the nose lean left/right...

When leans right, adjust the trim to left side.  
When leans left, adjust the trim to right side.

在直昇機正要起飛時，機頭朝左/右方向偏移...  
向右偏移時，微調向左調整。  
向左偏移時，微調向右調整。

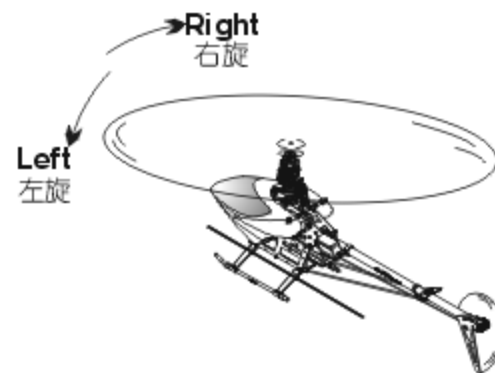
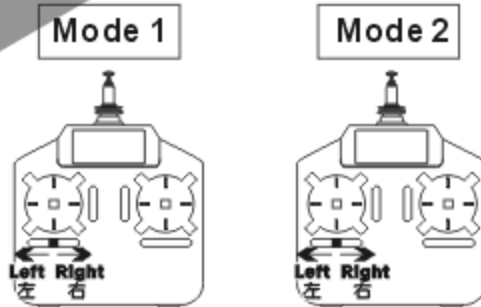

#### 2. Adjustment of elevator trim 調整升降舵微調

Just before the helicopter lift-off, the nose lean forward/backward...

When leans forward, adjust the trim down.  
When leans backward, adjust the trim up.

在直昇機正要起飛時，機頭朝前/後方向偏移...  
向前偏移時，微調向下調整。  
向後偏移時，微調向上調整。

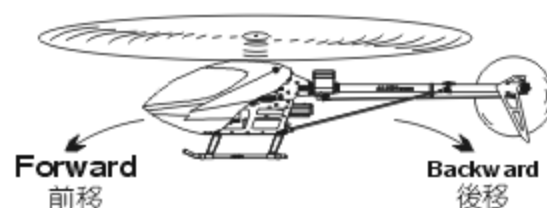
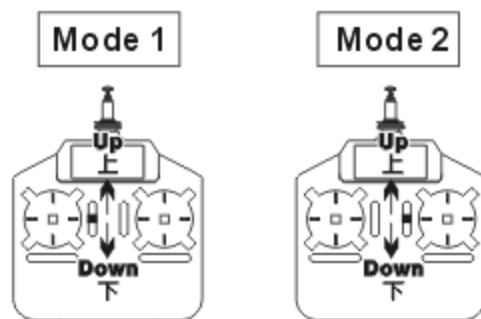

#### 3. Adjustment of Aileron trim 調整副翼微調

Just before the helicopter lift-off, the body lean left/right...

When leans right, adjust the trim to left side.  
When leans left, adjust the trim to right side.

在直昇機正要起飛時，機身朝左/右方向偏移...  
向右偏移時，微調向左調整。  
向左偏移時，微調向右調整。

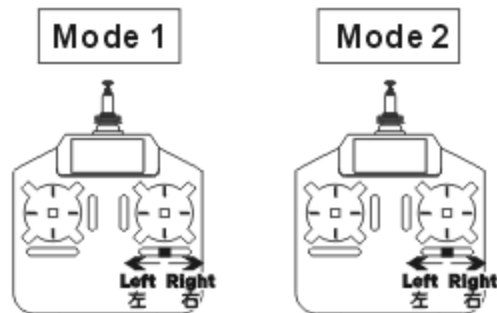

**TROUBLE SHOOTING DURING FLIGHT 如何排除飛行中的狀況**

	Situation 狀況	Cause 原因	Way to deal 對策
<b>Blade Tracking</b> 雙槳平衡	<b>Out of tracking</b> 雙槳	<b>Adjustment of pitch rod has not been done.</b> PITCH連桿長度調整不平均	<b>Adjust the length of linkage rod(C)</b> →Slight trim 調整連桿 (C) 長度
<b>During Hovering</b> 停旋	<b>Low rotation of the rotor</b> 主旋翼轉速偏低	<ul style="list-style-type: none"> <li>★ Pitch of main blade is high.</li> <li>★ 主旋翼的PITCH偏高</li> <li>★ Throttle curve is too low during hovering.</li> <li>★ 停旋點油門曲線過低</li> </ul>	<ul style="list-style-type: none"> <li>★ Lower the pitch about 5°~6° during hovering (The rotation should be about 3,300~3,500rpm during hovering).</li> <li>★ 調低Pitch停旋Pitch約5°-6° (停旋時主旋翼需為約3,300-3,500rpm)</li> <li>★ Heighten the throttle curve during hovering.</li> <li>★ 調高停旋點油門曲線</li> </ul>
	<b>High rotation of the rot or</b> 主旋翼轉速偏高	<ul style="list-style-type: none"> <li>★ Pitch of main blade is low.</li> <li>★ 主旋翼的PITCH偏低</li> <li>★ Throttle curve is too high during hovering.</li> <li>★ 停旋點油門曲線過高</li> </ul>	<ul style="list-style-type: none"> <li>★ Adjust the pitch rod(C)(The rotation should be about 3,300~3,500rpm during hovering).</li> <li>★ 調整連桿 (C) (停旋時主旋翼需為約3,300-3,500RPM)</li> <li>★ Lower the throttle curve during hovering.</li> <li>★ 調低停旋點油門曲線</li> </ul>
<b>Sensitivity of the gyro</b> 陀螺儀感度	<b>The tail leans to one side during hovering, or when trim the rudder and return to the neutral, the tail lags and cannot stay in a control position.</b> 停旋時尾翼向某一邊偏移，或撥動方向舵並回復到中立點時，尾翼產生延遲，無法停頓在所控制位置上。	<ul style="list-style-type: none"> <li>★ Failure setting of tail neutral point.</li> <li>★ 尾中立點設定不當</li> <li>★ The sensitivity of the gyro is low.</li> <li>★ 陀螺儀感度偏低</li> </ul>	<ul style="list-style-type: none"> <li>★ Reset tail neutral point.</li> <li>★ 重設尾中立點</li> <li>★ Increase the sensitivity.</li> <li>★ 增加感度</li> </ul>
	<b>The tail wags left and right during flight at hovering or full speed.</b> 停懸或全油門時尾翼左右來回搖擺。	<b>The sensitivity of the gyro is high.</b> 陀螺儀感度偏高	<b>Decrease the sensitivity.</b> 降低感度

※ If the problem is still there even after tried above, stop flying and contact with your seller.

※ 在做完以上調整後，仍然無法改善情況時，應立即停止飛行並連絡您的經銷商。

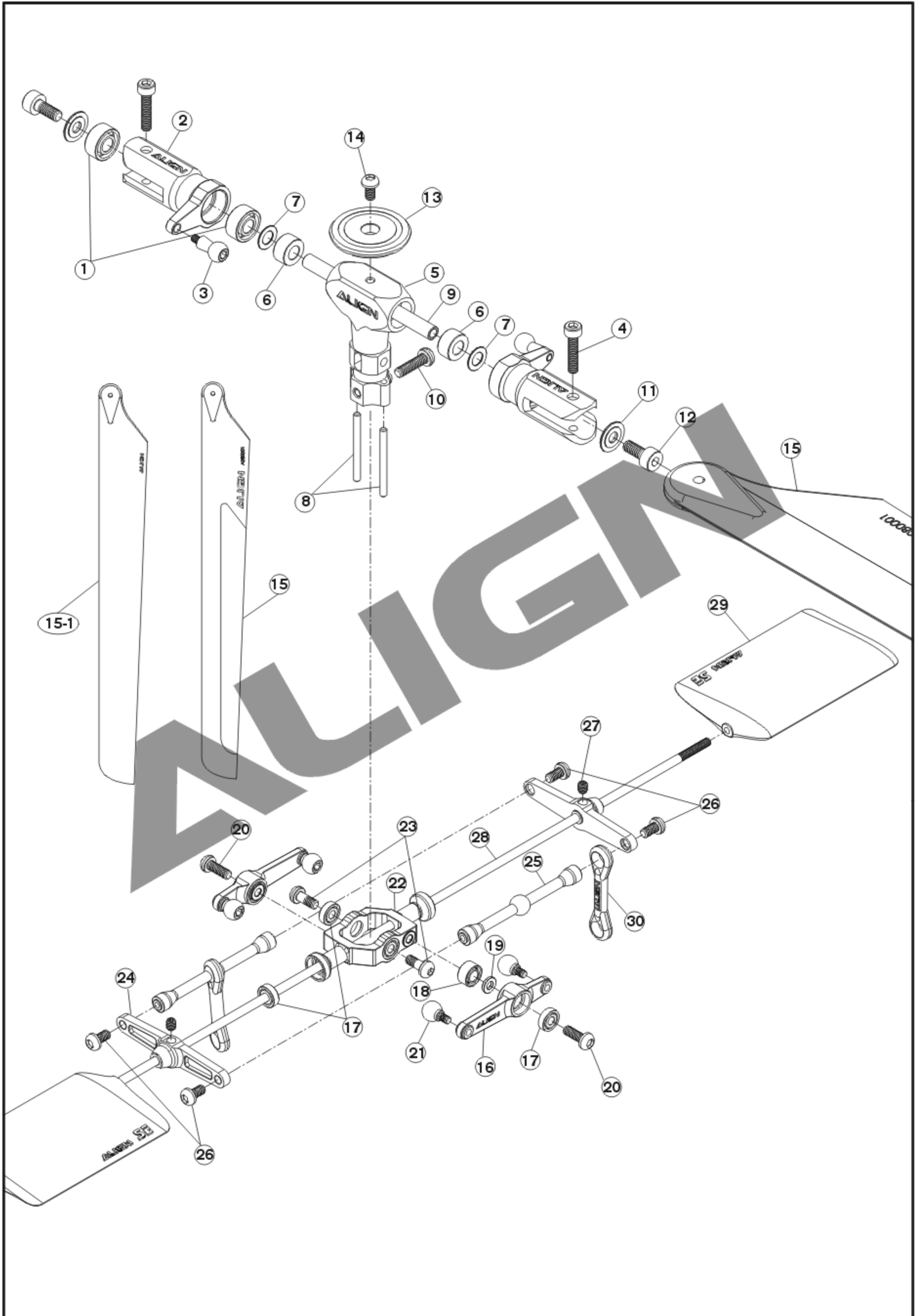

No.	Code No.	Name	Specification	Quantity	Remarks
1	H682XZZ	Bearing 軸承	φ 2.5x φ 6x2.6mm	4	
2	25H003A	Metal main rotor holder 金屬主旋翼夾座		2	
3	25Z005-1	Linkage ball B (0#x1.8) 球頭B (0#x1.8)	φ 3.5x7.32mm	2	
4	T52008-2	Socket screw 圓頭內六角螺絲	M2x8mm	2	
5	25H005A	Metal main rotor housing 金屬主旋翼固定座		1	
6	25H022	Damper rubber 70° 橫軸墊圈 70°	φ 2.5x φ 5x2.6mm	2	
7	25H023	Spacer 橫軸墊片	φ 2.5x φ 4.5x0.2mm	2	
8	25H017	Pin 定位插梢	φ 1.2x14mm	2	
9	25H020	Feathering shaft 橫軸	φ 2.5x30.8mm	1	
10	T50006-1	Socket button head screw 半圓頭內六角螺絲	0#x6mm	1	
11	W10020-5	Washer 橫軸華司	φ 2x φ 5.7x0.5mm	2	
12	T52005	Socket screw 圓頭內六角螺絲	M2x5mm	2	
13	25H018	Metal head stopper 金屬旋翼頭制動器	φ 14x3.5mm	1	
14	T50004-2	Socket button head screw 半圓頭內六角螺絲	0#x4mm	1	
15	25HA03	205D CF Main Blade 2050碳纖主旋翼	205mm	1set	
15-1	25H001A	205 Main Blade 205主旋翼	205mm	1set	
16	25H006A	Metal SF Mixing arm 金屬SF控制搖臂	19x3.5mm	2	
17	H681X	Bearing 軸承	φ 1.5x φ 4x1.2mm	6	
18	H681ZZ	Bearing 軸承	φ 1.5x φ 4x2mm	2	
19	W10015-1	Washer 華司	φ 1.5x φ 3x0.5mm	2	
20	T50006-1	Socket button head screw 半圓頭內六角螺絲	0#x6mm	2	
21	25Z004-1	Linkage ball A (0#x2) 球頭A (0#x2)	φ 3.5x5.3mm	4	
22	25H004	Metal flybar seesaw holder 金屬平衡桿固定座		1	
23	T50004-3	Socket button head collar screw 半圓頭內六角軸套螺絲	0#x4mm	2	
24	25H007A	Metal flybar control arm 金屬平衡翼控制臂	23x5.2mm	2	
25	25H008	Flybar control rod 平衡翼球型控制球桿	φ 3x27.1mm	2	
26	T50003-1	Socket button head screw 半圓頭內六角螺絲	0#x3mm	4	
27	T72002	M2 Set screw M2止洩螺絲	M2x2mm	2	
28	25H019	Flybar rod 平衡翼桿	φ 1.5x152mm	1	
29	25H002A	Flybar paddle 平衡翼		2	
30	25Z003	Ball link B 連桿頭B		2	

**Specifications, contents of parts and availability are subject to change, Align RC is not responsible for inadvertent errors in this publications.**  
 本說明書內的材質、規格或零件包裝之內容物僅供參考。本公司將不對此印刷物之異動負責，也無法主動通知消費者，任何更新或異動，請以亞拓網頁為主。



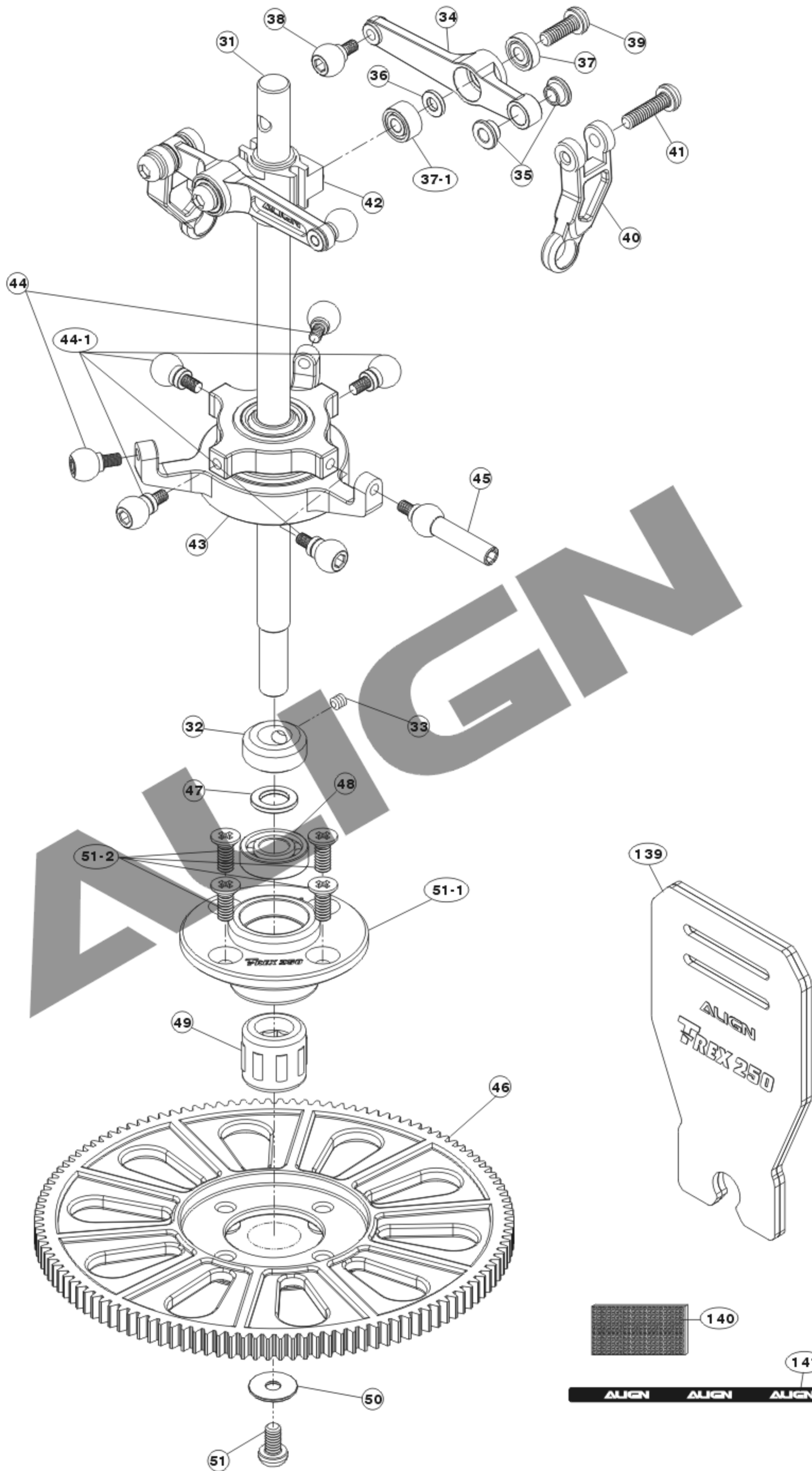

No.	Code No.	Name	Specification	Quantity	Remarks
31	25H024	Main shaft 主軸	φ 3x φ 3.5x78.8mm	1	
32	25H025	Lock collar 主軸固定環	φ 3.5x φ 6.5x2.8mm	1	
33	T72002	M2 Set screw M2止洩螺絲	M2x2mm	1	
34	25H010A	Metal washout control arm 金屬穩定控制搖臂		2	
35	25H030	Collar Radius襯套	φ 1.5x φ 2.3x φ 3.3x1.5mm	4	
36	W10015-1	Washer 華司	φ 1.5x φ 3x0.5mm	2	
37	H681X	Bearing 軸承	φ 1.5x φ 4x1.2mm	2	
37-1	H681ZZ	Bearing 軸承	φ 1.5x φ 4x2mm	2	
38	25Z004-1	Linkage ball A (0#x2) 球頭A(0#x2)	φ 3.5x5.3mm	2	
39	T50006-1	Socket button head screw 半圓頭內六角螺絲	0#x6mm	2	
40	25H011A	Radius arm Radius連桿		2	
41	S91506-1	Socket button head self tapping screw 半圓頭內六角自攻螺絲	T1.5x6mm	2	
42	25H009	Washout base 向位器	φ 3.5x8x7.4mm	1	
43		CCPM Metal Swashplate 金屬CCPM十字盤組		1	
44	25Z004-1	Linkage ball A (0#x2) 球頭A(0#x2)	φ 3.5x5.3mm	2	
44-1	25Z012	Linkage ball D (0#x2) 球頭D(0#x2)	φ 3.5x6mm	4	
45	25Z006-1	Long linkage ball (0#x2) 導板長球頭(0#x2)	φ 3.5x13.5mm	1	
46	25B031	New main drive gear(120T) 新型主齒盤(120T)	120T	1	
47	25B015-1	Spacer 單向墊片	φ 3x φ 4.8x0.5mm	1	
48	H683	Bearing 軸承	φ 3x φ 7x2mm	1	
49	HHF0306	One-way bearing shaft 單向軸承	φ 3x φ 6.5x6mm	1	
50	W10015-2	Washer 華司	φ 1.5x φ 5x0.3mm	1	
51	T50004-2	Socket button head screw 半圓頭內六角螺絲	0#x4mm	1	
51-1	25B032	Main gear case 主齒中心座		1	
51-2	S71504	Countersunk philips self tapping screw 皿頭十字自攻螺絲	T1.5x4mm	4	
139	25H029-1	Main blade holder 主旋翼固定架泡棉	75x44x5mm	1	
140	K10365	Hook and Loop Tape 魔術沾	54x28mm	1	
141	K10380	Hook and Loop fastening tape 魔術束帶	8x140mm	2	

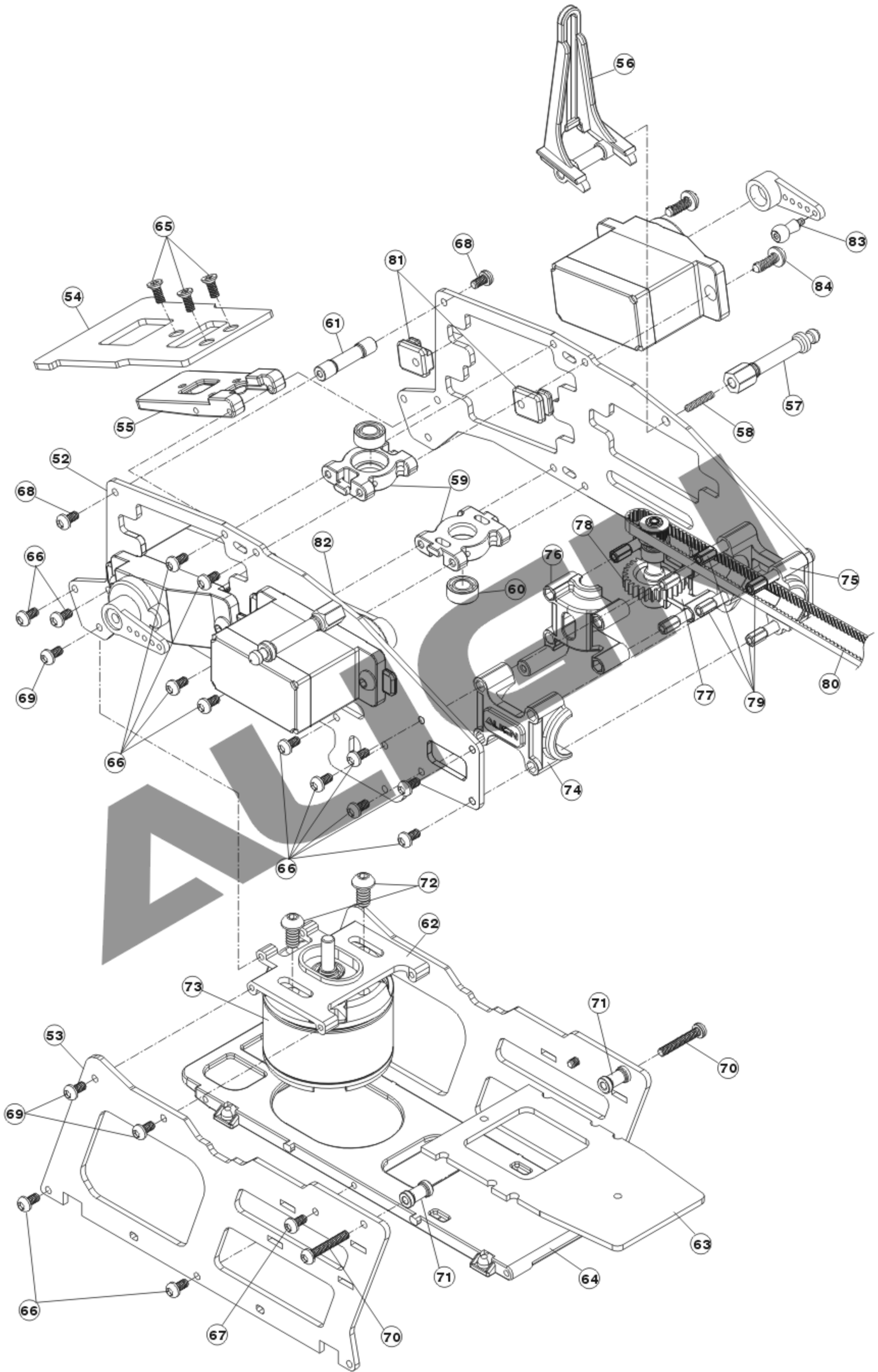



**CAUTION 注意**  
 For original manufactory package, if the product is already assembled by Factory, please check again if screws are firmly secured and applied with some glue.  
 原廠零件出廠包裝如果是組裝品，請需再確認各螺絲是否鎖緊上膠。

When tightening a screw to a plastic part, please tighten it firmly, but not over tightened, or they will strip.  
 螺絲鎖入塑膠件請務必注意，適當扭力鎖緊即可，而過緊的扭力可能會導致滑牙。

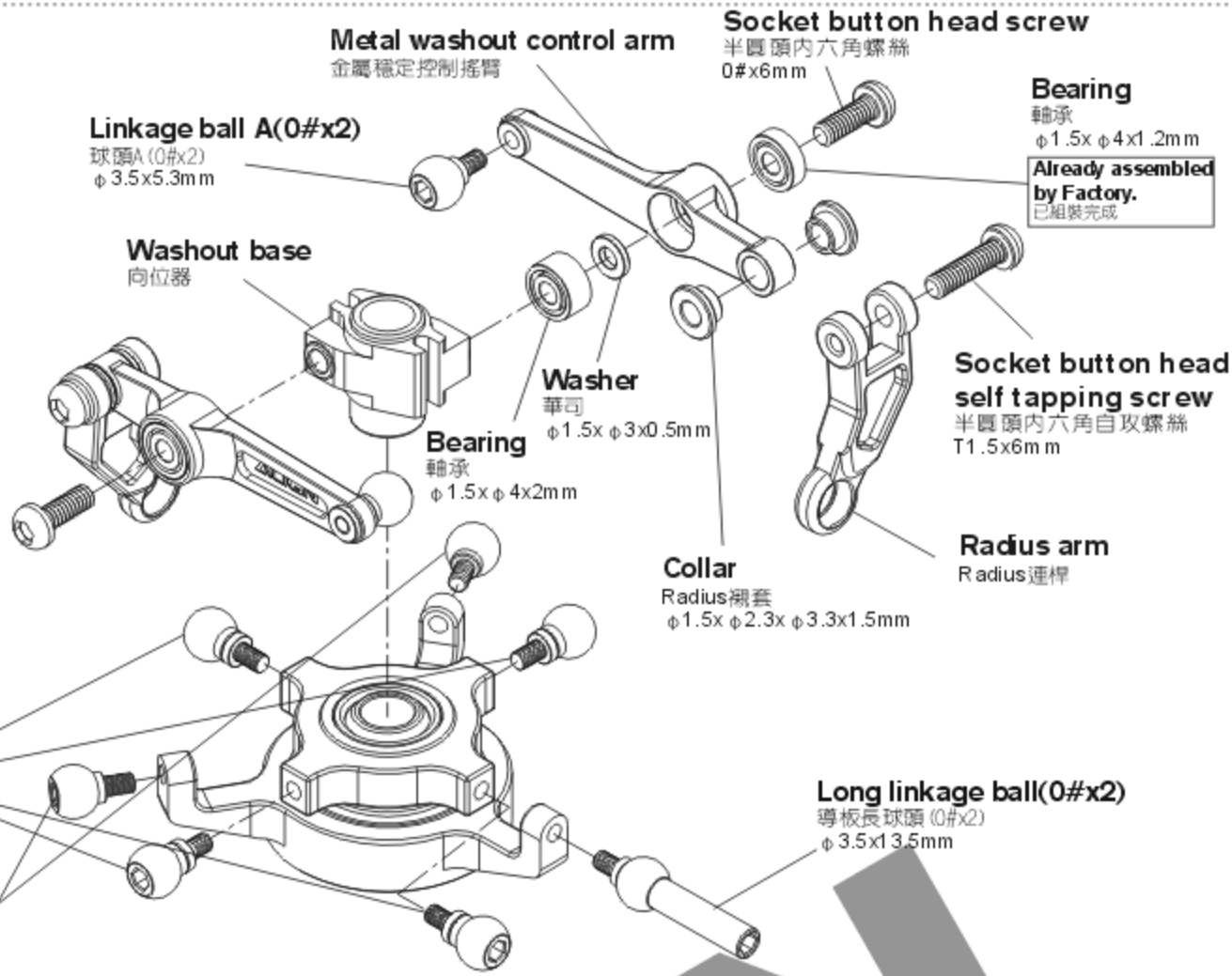

**250HH8**

- Socket button head self tapping screw**  
半圓頭內六角自攻螺絲(T1.5x6mm) x 2
- Washer**  
華司(φ1.5x φ3x0.5mm) x 2
- Bearing**  
軸承(φ1.5x φ4x1.2mm) x 2
- Bearing**  
軸承(φ1.5x φ4x2mm) x 2
- Socket button head screw**  
半圓頭內六角螺絲(0#x6mm) x 3
- Long linkage ball(0#x2)**  
導板長球頭(0#x2)(φ3.5x13.5mm) x 1
- Linkage ball A(0#x2)**  
球頭A(0#x2)(φ3.5x5.3mm) x 4
- Linkage ball A(0#x2)**  
球頭D(0#x2)(φ3.5x6mm) x 4

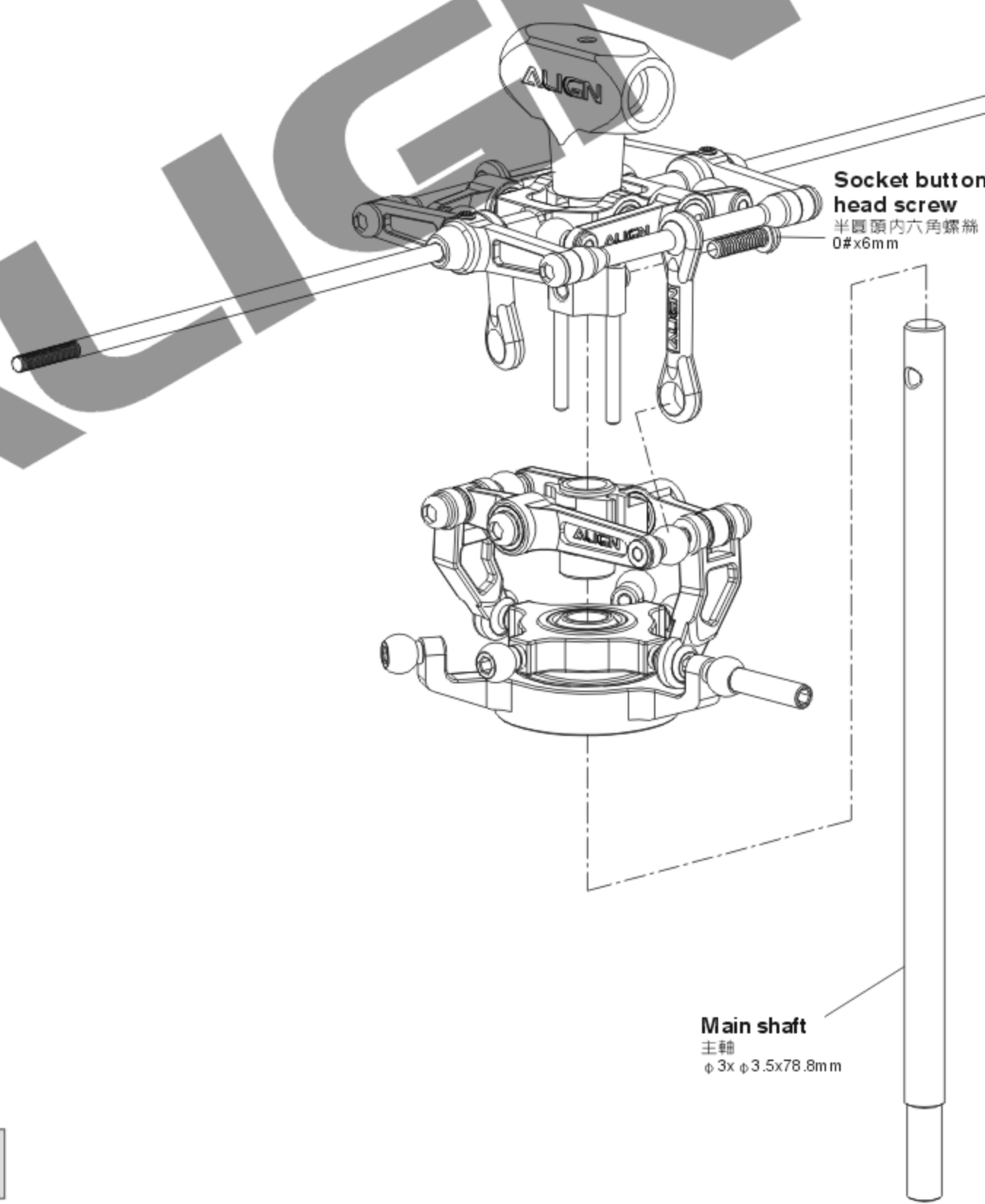

**Apply a little amount of T22 thread lock when fixing a metal part.**  
螺絲鎖對於金屬件請使用適量T22(螺絲膠)

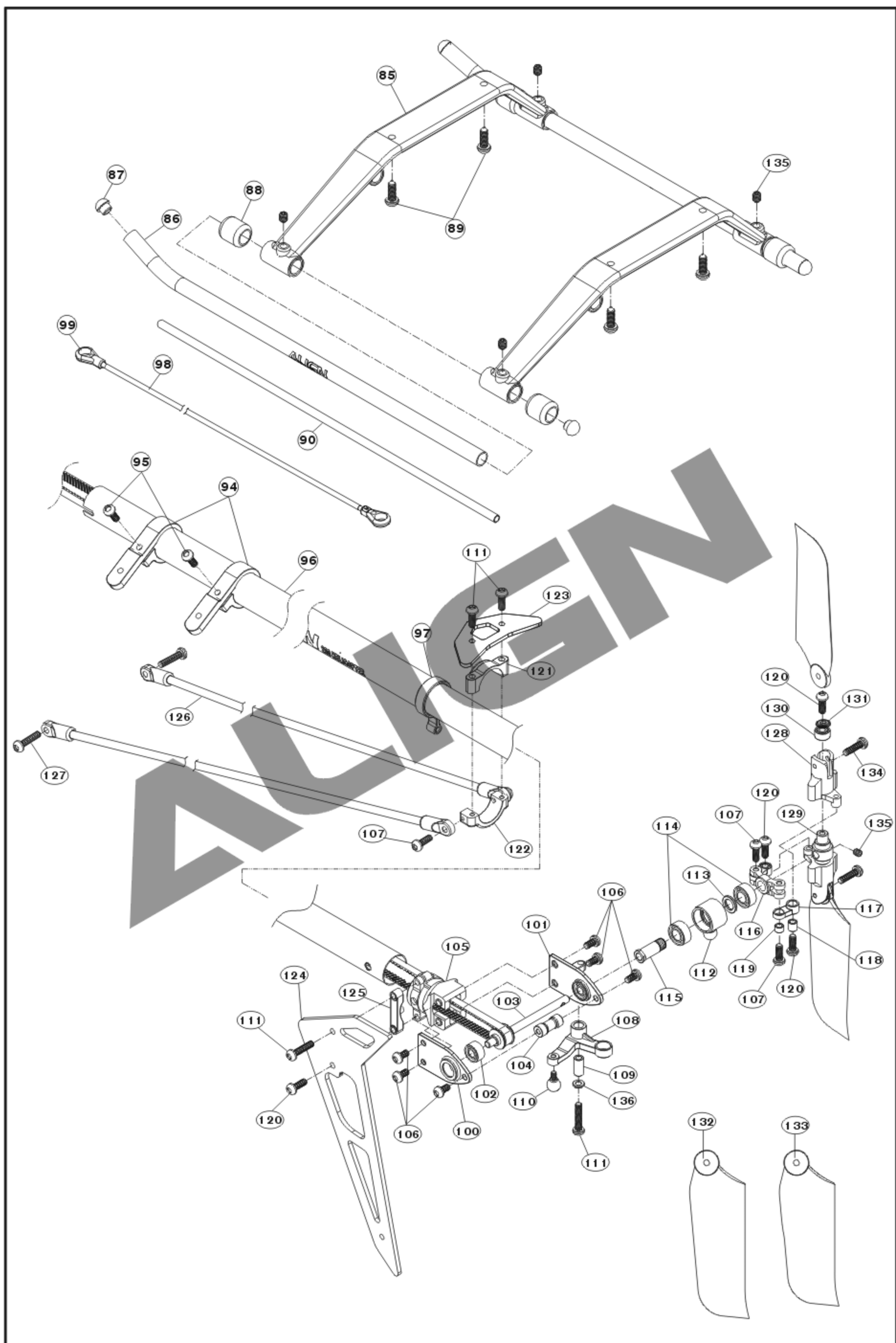

No.	Code No.	Name	Specification	Quantity	Remarks
94	25T007	Rudder servo mount 尾伺服器固定座		2	
95	S91506-1	Socket button head self tapping screw 半圓頭內六角自攻螺絲	T1.5x6mm	2	
96	25T001	Tail boom 尾管	φ 7.9x φ 8.5x241.7mm	1	
97	25T027	Tail control guide 尾控制桿固定環		1	
98	25T028	Rudder control rod 尾舵控制連桿	φ 1.2x210mm	1	
99	25Z001	Ball link 連桿頭		2	
100	25T004	Metal plate(L) 尾齒箱左側板	15x6x2.9mm	1	
101	25T005A	Metal plate(R) 尾齒箱右側板	15x6x2.9mm	1	
102	HMR52ZZ	Bearing 軸承	φ 2x φ 5x2.5mm	2	
103		Metal tail rotor shaft assembly 金屬尾旋翼主軸組		1	
104	25T003	Aluminum bolt 尾齒輪座鋁套	φ 3.5x7.6mm	1	
105	25T002A	Metal tail belt unit 金屬尾皮帶尾齒箱	φ 8.5x10.7x7.6mm	1	
106	T50003-1	Socket button head screw 半圓頭內六角螺絲	0#x3mm	6	
107	T50004-2	Socket button head screw 半圓頭內六角螺絲	0#x4mm	4	
108	25T020-1	Tail rotor control arm 尾旋翼控制臂		1	
109	25T026A	Collar 尾旋翼控制臂軸套	φ 1.5x φ 2.5x5mm	1	
110	25Z004-1	Linkage ball A (0#x2) 球頭A(0#x2)	φ 3.5x5.3mm	1	
111	T50008-1	Socket button head screw 半圓頭內六角螺絲	0#x8mm	4	
112	25T021	Bearing holder 尾旋翼軸承套		1	
113	W10030-2	Washer 華司	φ 3x φ 4.8x0.6mm	1	
114	HMR63ZZ	Bearing 軸承	φ 3x φ 6x2.5mm	2	
115	25T009	Slide shaft 尾軸滑套	φ 2x φ 3x8.4mm	1	
116	25T010	T type arm 尾T型控制臂		1	
117	25T011	Control link 尾控制連桿頭		2	
118	25T014A	Collar A 尾連桿頭軸套A	φ 1.5x φ 2.3x2.4mm	2	
119	25T015A	Collar B 尾連桿頭軸套B	φ 1.5x φ 2.3x1.4mm	2	
120	T50005-1	Socket button head screw 半圓頭內六角螺絲	0#x5mm	5	
121	25T035	Metal stabilizer mount (Upper) 金屬水平翼固定上座		1	
122	25T036	Metal stabilizer mount (Lower) 金屬水平翼固定下座		1	
123	25T018-1	Carbon fiber horizontal stabilizer 碳纖水平翼		1	
124	25T016-1	Carbon fiber vertical stabilizer 碳纖垂直翼		1	
125	25T023	Vertical stabilizer mount 垂直翼固定座		1	
126	25T030-1	Tail boom bracer 尾管支撐架組		2	
127	S91506-1	Socket button head self tapping screw 半圓頭內六角自攻螺絲	T1.5x6mm	2	
128	25T044A	New metal tail rotor holder 新型金屬尾旋翼夾座		2	
129	25T012A	Tail rotor hub 尾旋翼T型座	φ 2.9x φ 5.4x11.2mm	1	
130	H681ZZ	Bearing 軸承	φ 1.5x φ 4x2mm	2	
131	25T017	Washer 尾夾座華司	φ 1.5x φ 3.8x0.7mm	2	
132	25T022A	40 Tail blade 40尾旋翼	40mm	2	
133	25T041A	37 Tail blade 37尾旋翼	37mm	2	
134	T50006-1	Socket button head screw 半圓頭內六角螺絲	0#x6mm	2	
135	T72002	M2 Set screw M2止洩螺絲	M2x2mm	5	
136	W10015-1	Washer 華司	φ 1.5x φ 3x0.5mm	1	

# ALIGN

## Specifications & Equipment/規格配備:

Length/機身長: 430mm

Height/機身高: 163mm

Main Blade Length/主旋翼長: 205mm

Main Rotor Diameter/主旋翼直徑: 460mm

Tail Rotor Diameter/尾旋翼直徑: 108mm

Motor Pinion Gear/馬達主齒: 15T

Main Drive Gear/傳動主齒: 120T

Tail Drive Gear/尾翼傳動齒: 28T

Drive Gear Ratio/齒輪傳動比: 1:8:4.28

Weight(Without Power System)/空機重: 148g

Flying Weight/全配重: Approx. 340g

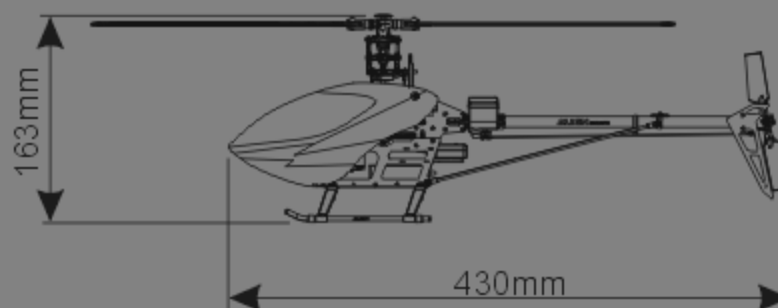
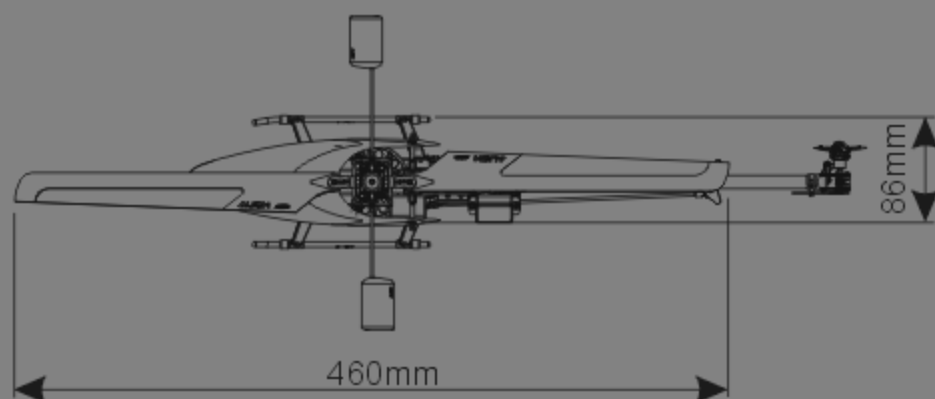

## Features:

- ★Electric power system. ★Rigid carbon fiber frame design.
- ★Simple and light weight design provides awesome flight performance and extreme 3D capability.
- ★Beautiful factory painted fiberglass canopy. ★Tail rotor drive belt system.
- ★ $\phi$  3.5mm main shaft ★ $\phi$  2.5mm Feathering shaft ★ $\phi$  8.5mm Tail boom
- ★Center of gravity of Battery tray designed close to the rotor head.