

# Fiberglass Frame **T-REX 600 GF**

## INSTRUCTION MANUAL 使用說明書



Thank you for buying ALIGN products. The **T-REX 600** is the latest technology in Rotary RC models. Please read this manual carefully before assembling and flying the new **T-REX 600** helicopter. We recommend that you keep this manual for future reference regarding tuning and maintenance.

承蒙閣下選用亞拓遙控世界系列產品，謹表謝意。進入遙控世界之前必須告訴您許多相關的知識與注意事項，以確保您能夠在學習的過程中較得心應手。在開始操作之前，請務必詳閱本說明書，相信一定能夠給您帶來相當大的幫助，也請您妥善保管這本說明書，以作為日後參考。

### Contents

1	INTRODUCTION 前言
2	SAFETY NOTES 安全注意事項
3	SAFETY CHECK BEFORE FLYING 飛行前安全檢查
4~17	ASSEMBLY SECTION 組裝說明
18	EQUIPMENT ILLUSTRATION 設備建議配置圖示
19	CANOPY ASSEMBLY 機頭罩安裝
19	SERVO AND LINKAGE ROD SETTING 伺服器與連桿設定說明
20	SERVO SETTING AND ADJUSTMENT 伺服器設定調整
20	ADJUSTMENTS FOR GYRO AND TAIL NEUTRAL SETTING 陀螺儀與尾翼中立點調整
21	PITCH AND THROTTLE SETTING 主旋翼螺距與油門設定
22~23	RCE-BL100G BRUSHLESS SPEED CONTROLLER INSTRUCTION MANUAL 無刷調速器使用說明
23~24	6A EXTERNAL BEC INSTRUCTION MANUAL 6A外接式BEC使用說明
24~26	FLIGHT ADJUSTMENT AND SETTING 飛行動作調整與設定
27~34	PART NAMES AND OPTIONAL PART LIST 各部零件名稱與選購備品明細

Thank you for buying ALIGN Products. The T-REX 600 Helicopter is designed as an easy to use, full featured Helicopter R/C model capable of all forms of rotary flight. Please read the manual carefully before assembling the model, and follow all precautions and recommendations located within the manual. Be sure to retain the manual for future reference, routine maintenance, and tuning. The T-REX 600 is a new product developed by ALIGN. It features the best design available on the Micro-Heli market to date, providing flying stability for beginners, full aerobatic capability for advanced fliers, and unsurpassed reliability for customer support.

感謝您選購亞拓產品，為了讓您容易方便的使用 T-REX 600 直昇機、請您詳細的閱讀完這本說明書之後再進行組裝以及操作這台直昇機，同時請您妥善的保存這本說明書、作為日後進行調整以及維修的參考。T-REX 600 是由亞拓自行研發的新產品，不論你是需求飛行穩定性的初學者或是追求性能的飛行愛好者。T-REX 600 將是你最佳的選擇。

## THE MEANING OF SYMBOLS 標誌代表涵義

	<b>Mishandling due to failure to follow these instructions may result in damage or injury.</b> 因為疏忽這些操作說明，而使用錯誤可能造成財產損失或嚴重傷害。
	<b>Mishandling due to failure to follow these instructions may result in danger.</b> 因為疏忽這些操作說明，而使用錯誤可能造成危險。
	<b>Do not attempt under any circumstances.</b> 在任何禁止的環境下，請勿嘗試操作。

## IMPORTANT NOTES 重要聲明

**R/C helicopters, including the T-REX 600 are not toys.** R/C helicopter utilize various high-tech products and technologies to provide superior performance. Improper use of this product can result in serious injury or even death. Please read this manual carefully before using and make sure to be conscious of your own personal safety and the safety of others and your environment when operating all ALIGN products. **Manufacturer and seller assume no liability for the operation or the use of this product.** Intended for use only by adults with experience flying remote control helicopters.



*It is not a Toy!*

After the sale of this product we cannot maintain any control over its operation or usage.

**T-REX 600**遙控直昇機並非玩具，它是結合了許多高科技產品所設計出來的休閒用品，所以商品的使用不當或不熟悉都可能會造成嚴重傷害甚至死亡，使用之前請務必詳讀本說明書，勿輕忽並注意自身安全。注意！任何遙控直昇機的使用，製造商和經銷商是無法對使用者於零件使用的損耗異常或組裝不當所發生之意外負任何責任，本產品是提供給有操作過模型直昇機經驗的成人或有相當技術的人員在旁指導，以確保安全無虞下操作使用，產品售出後本公司將不負任何操作和使用控制上的任何性能與安全責任。

We recommend that you obtain the assistance of an experienced pilot before attempting to fly our products for the first time. A local expert is the best way to properly assemble, setup, and fly your model for the first time. The T-REX 600CF requires a certain degree of skill to operate, and is a consumer item. Any damage or dissatisfaction as a result of accidents or modifications are not covered by any warrantee and cannot be returned for repair or replacement. Please contact our distributors for free technical consultation and parts at discounted rates when you experience problems during operation or maintenance.

模型商品屬於操作技術且為消耗性商品，如經拆裝使用後，會造成不等情況零件損耗，任何使用情況所造成商品不良或不滿意，將無法於保固條件內更換新品或退貨，如遇有使用操作維修問題，本公司全省分公司將提供免費技術指導、特價零件供應服務。



**Fly only in safe areas, away from other people. Do not operate R/C aircraft within the vicinity of homes or crowds of people. R/C aircraft are prone to accidents, failures, and crashes due to a variety of reasons including, lack of maintenance, pilot error, and radio interference. Pilots are responsible for their actions and damage or injury occurring during the operation or as of a result of R/C aircraft models.**

遙控模型飛機、直昇機屬高危險性商品，飛行時務必遠離人群，人為組裝不當或機件損壞、電子控制設備不良，以及操控上的不熟悉、都有可能導致飛行失控損傷等意外，請飛行者務必注意飛行安全，並需了解自負任何意外之責任。

## RADIO TRANSMITTER AND ELECTRONIC EQUIPMENT REQUIRED FOR ASSEMBLY 自備遙控及電子設備

Transmitter(6-channel or more, helicopter system) 發射機(六動以上直昇機模式遙控器)	Receiver(6-channel or more) 接收機(六動以上)	Head Lock Gyro 鎖定式陀螺儀	STD Servo 3pcs (movements) Specialized servo 1 pc (Tail rudder) 動作控制STD伺服器x3 尾舵控制專用伺服器x1

## ADDITIONAL TOOLS REQUIRED FOR ASSEMBLY 自備工具

Scissors 剪刀	Cutter Knife 刀子	Grease 潤滑油	CA 瞬間膠	Diagonal Cutting Pliers 斜口鉗	Needle Nose Pliers 尖嘴鉗	Hexagon Screw Driver 六角螺絲起子 3mm/2.5mm/2mm/1.5mm	Philips Screw Driver 十字螺絲起子 φ 3.0/φ 1.8mm



### LOCATE AN APPROPRIATE LOCATION 遠離障礙物及人群

R/C helicopters fly at high speed, thus posing a certain degree of potential danger. Choose an appropriate flying site consisting of flat, smooth ground, a clear open field, or a large open room, such as gymnasium or warehouse without obstacles. Do not fly near buildings, high voltage cables, or trees to ensure the safety of yourself, others, and your model. Do not fly your model in inclement weather, such as rain, wind, snow or darkness.

直昇機飛行時具有一定的速度，相對的也潛在著一點危險性，場地的選擇也相對的重要。首先必須注意周遭有沒有人、高樓、建築物、高壓電線、樹木等等，避免操控的不當造成自己與他人財產的損壞。初次練習時，務必選擇在空曠場地並可適當搭配練習架練習飛行，這對飛行失誤所造成的損傷將會大幅的降低。請勿在下雨、打雷等惡劣天候下操作，以確保本身及機體的安全。



### OBTAIN THE ASSISTANCE OF AN EXPERIENCED PILOT 避免獨自操控

Before turning on your model and transmitter, check to make sure no one else is operating on the same frequency. Frequency interference can cause your model, or other models to crash. The guidance provided by an experienced pilot will be invaluable for the assembly, tuning, trimming, and actual first flight. (Recommend you to practice with computer-based flight simulator.)

至飛行場飛行前，需確認是否有相同頻率的同好正進行飛行，因為開啓相同頻率的發射機將導致自己與他人立即干擾等意外危險。遙控飛機操控技巧在學習初期有著一定的難度，要盡量避免獨自操作飛行，需有經驗的人士在旁指導，才可以操控飛行。  
(勤練電腦模擬器及老手指導是入門必要的選擇)



### ALWAYS BE AWARE OF THE ROTATING BLADES 遠離運轉中零件

During the operation of the helicopter, the main rotor and tail rotor will be spinning at a high rate of speed. The blades are capable of inflicting serious bodily injury and damage to the environment. Be conscious of your actions, and careful to keep your face, eyes, hands, and loose clothing away from the blades. Always fly the model a safe distance from yourself and others, as well as surrounding objects. Never take your eyes off the model or leave it unattended while it is turned on. Immediately turn off the model and transmitter when you have landed the model.

當直昇機主旋翼與尾旋翼運轉時，切勿觸摸並遠離任何物件，以避免造成危險及損壞。



### PREVENT MOISTURE 遠離潮濕環境

R/C models are composed of many precision electrical components. It is critical to keep the model and associated equipment away from moisture and other contaminants. The introduction or exposure to water or moisture in any form can cause the model to malfunction resulting in loss of use, or a crash. Do not operate or expose to rain or moisture.

直昇機內部也是由許多精密的電子零組件組成，所以必須絕對的防止潮濕或水氣，避免在浴室或雨天時使用，防止水氣進入機身內部而導致機件及電子零件故障而引發不可預期的意外！



### KEEP AWAY FROM HEAT 遠離熱源

R/C models are made up various forms of plastic. Plastic is very susceptible to damage or deformation due to extreme heat and cold climate. Make sure not to store the model near any source of heat such as an oven, or heater. It is best to store the model indoors, in a climate-controlled, room temperature environment.

遙控飛機多半是以 PA 纖維或聚乙烯、電子商品為主要材質，因此要盡量遠離熱源、日曬，以避免因高溫而變形甚至熔毀損壞的可能。



### PROPER OPERATION 勿不當使用本產品

Please use the replacement of parts on the manual to ensure the safety of instructors. This product is for R/C model, so do not use for other purpose.

請勿自行改造加工，任何的升級改裝或維修，請使用亞拓產品目錄中的零件，以確保結構的安全。請確認於產品限界內操作，請勿過載使用，並勿用於安全、法令外其它非法用途。



### SAFE OPERATION 安全操作

Operate this unit within your ability. Do not fly under tired condition and improper operation may cause in danger.

請於自己能力內及需要一定技術範圍內操作這台直昇機，過於疲勞、精神不佳或不當操作，意外發生風險將可能會提高。



#### CAREFULLY INSPECT BEFORE REAL FLIGHT 實機飛行前請嚴格執行飛行前檢查義務

- ★ Before flying, please check to make sure no one else is operating on the same frequency for the safety.
- ★ Before flight, please check if the batteries of transmitter and receiver are enough for the flight.
- ★ Before turn on the transmitter, please check if the throttle stick is in the lowest position. IDLE switch is OFF.
- ★ When turn off the unit, please follow the power on/off procedure. Power ON- Please turn on the transmitter first, and then turn on receiver. Power OFF- Please turn off the receiver first and then turn off the transmitter. Improper procedure may cause out of control, so please to have this correct habit.
- ★ Before operation, check every movement is smooth and directions are correct. Carefully inspect servos for interference and broken gear.
- ★ Check for missing or loose screws and nuts. See if there is any cracked and incomplete assembly of parts. Carefully check main rotor blades and rotor holders. Broken and premature failures of parts possibly cause resulting in a dangerous situation.
- ★ Check all ball links to avoid excess play and replace as needed. Failure to do so will result in poor flight stability.
- ★ Check the battery and power plug are fastened. Vibration and violent flight may cause the plug loose and result out of control.
- ★ Check for the tension of tail drive belt.

- ★ 每次飛行前應先確認所使用的頻率是否會干擾他人，以確保你自身與他人的安全。
- ★ 每次飛行前確定您發射機與接收機電池的電量是在足夠飛行的狀態。
- ★ 開機前確認油門搖桿是否位於最低點，熄火降落開關，定速開關(IDLE)是否於關閉位置。
- ★ 關機時必須遵守電源開關機的程序，開機時應先開啓發射機後，再開啓接收機電源；關機時應先關閉接收機後，再關閉發射機電源。不正確的開關機程序可能會造成失控的現象，影響自身與他人的安全，請養成正確的習慣。
- ★ 開機請先確定直昇機各個動作是否順暢，及方向是否正確，並檢查伺服器的動作是否有干涉或崩齒的情形，使用故障的伺服器將導致不可預期的危險。
- ★ 飛行前確認沒有缺少或鬆脫的螺絲與螺帽，確認沒有組裝不完整或損毀的零件，仔細檢查主旋翼是否有損壞，特別是接近主旋翼夾座的部位。損壞或組裝不完整的零件不僅影響飛行，更會造成不可預期的危險。注意：對損耗、有裂痕零件更新及定期保養檢查重要性。
- ★ 檢查所有的連桿頭是否有鬆脫的情形，過鬆的連桿頭應先更新，否則將造成直昇機無法操控的危險。
- ★ 確認電池及電源接頭是否固定牢靠，飛行中的震動或激烈的飛行，可能造成接頭鬆脫而造成失控的危險。
- ★ 確定尾傳動皮帶的鬆緊度。

Product Name 產品名稱	Standard Equipment 標準配備
T-REX 600GF Combo Version  T-REX 600GF 高級玻纖套裝版	▲T-REX 600(GF) Kit Set x 1▲Fiberglass Canopy x 1▲Decal x 1▲3D Landing Skid x 1▲Hook & Loop Fastening Tape x 2 ▲Motor Pinion Gear 14T x 1▲RCE-BL100G 100A Brushless ESC(Governor Mode) x 1▲650L Brushless motor x 1 ▲REC-B6X 6A External BEC w/ 5.1V Two-way Step-down voltage regulator x 1★W/O Main Blade ▲Li-Polymer 7.4V 1900mAh 18C for BEC x 1 ▲T-REX 600(GF)空機版x1▲玻纖機頭罩x1▲貼紙x1▲3D腳架x1組▲魔術帶x2▲14T馬達齒輪 x1★未附主旋翼 ▲RCE-BL100G 100安培無刷定速調速器x1組▲650L無刷馬達x1▲REC-B6X 6A外接式BEC(含5.1V雙向降壓器)x1 ▲Li-Polymer 7.4V 1900mAh 18C x 1
T-REX 600GF Kit Version T-REX 600GF 高級玻纖空機版	▲T-REX 600(GF) Kit Set x 1▲Fiberglass Canopy x 1▲Decal x 1▲3D Landing Skid x 1▲Hook & Loop Fastening Tape x 2 ▲Motor Pinion Gear 14T x 1★W/O Main Blade  ▲T-REX 600(GF)空機版x1▲玻纖機頭罩x1▲貼紙x1▲3D腳架x1組▲魔術帶x2▲14T馬達齒輪x1★未附主旋翼



Original manufacture package of T-REX 600GF is not including main blades. This unit is a large-sized high power helicopter, and we recommend you to choose safe main blades with good brand, reputation. We recommend you do not use general wooden blades and do not equip the power of main blade over 2150rpm to avoid any accident caused by broken structure of the blades and parts.

本公司 T-REX 600GF 遙控模型直昇機原裝出廠商品未附主旋翼，由於此商品屬大型高動力直昇機，具有一定危險性，為了安全在你選購搭配主旋翼時，務必注意慎選使用有品牌、有認證、安全的商品，建議禁止使用一般木槳，並嚴格禁止於任何情況下主旋翼轉速超過2150rpm，以避免主旋翼或機體零件結構斷裂造成不可預期的意外。

When you see the marks as below, please use glue or grease to ensure flying safety.

標有下符號之組裝步驟，請配合上膠或上油，以確保使用之可靠度。



- CA: Apply CA Glue to fix.
- R48: Apply Anaerobics Retainer to fix.
- T43: Apply Thread Lock to fix.
- OIL: Add Grease.
- CA: 使用瞬間膠固定
- R48: 使用缺氧膠固定
- T43: 使用螺絲膠
- OIL: 添加潤滑油

When assembling ball links, make sure the "A" character faces outside.

各項塑膠製連桿頭扣接時，A字請朝外。

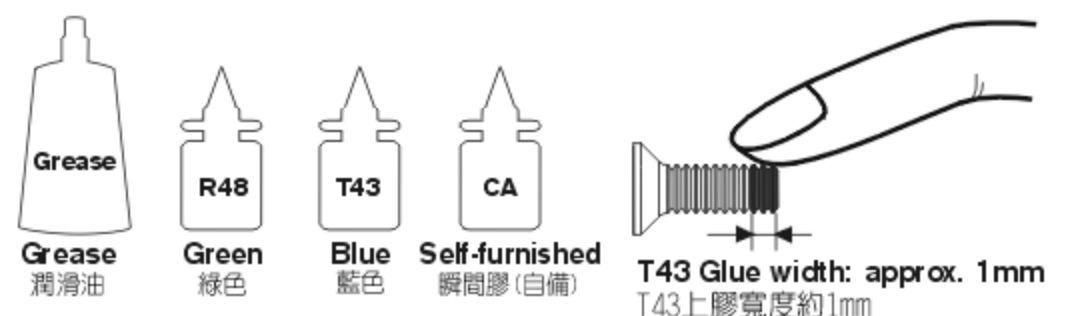

R48 metal tubular adhesive (eg. Bearings). T43 thread lock, apply a small amount on screws or metal parts and wipe surplus off. When disassembling, recommend to heat the metal joint about 15 Seconds.(NOTE: Keep plastic parts away from heat.) R48 為強力金屬管狀(如軸承)接著劑，T43為螺絲膠，膠合螺絲或金屬內外徑請務必少量使用，必要時請用手去除多餘膠量，欲拆卸時可於金屬接合部位熱烤約15秒。(注意！塑膠件避免接近熱源)

## 50HH001

**Linkage ball B(T2.6x5.5)**  
球頭B (T2.6x5.5) (φ 4.75x12.27mm) x 2

**Bearing MR148ZZ**  
MR148ZZ軸承 (φ 8x φ 14x4mm) x 4

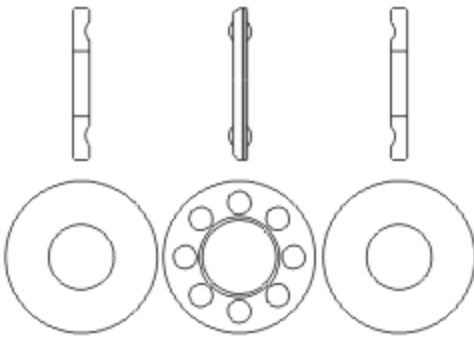

**Thrust bearing**  
止推軸承 (φ 6x φ 14x5mm) x 2

**Spindle bearing spacer**  
橫軸軸承墊片 (φ 10x φ 13.8x0.4mm) x 4

**Main Blade Fixing Screw**  
鎖主旋翼用螺絲



**Socket collar screw**  
圓頭內六角軸套螺絲 (M4x27mm) x 2



**M4 Nut**  
M4防鬆螺帽 x 2

**CAUTION**  
注意

**Apply grease on thrust bearing.**  
止推軸承塗上潤滑油

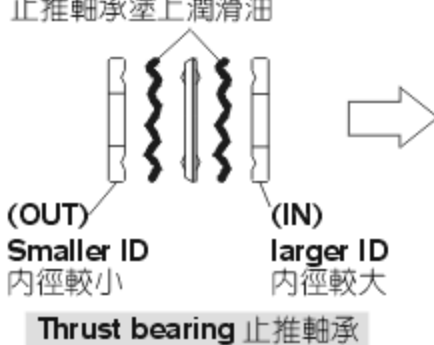

**Obverse of bearing faces inside.**  
軸承面凹開口朝內

**CAUTION**  
注意

**When tightening a linkage ball to a plastic part, please note to use a little CA glue and tighten it firmly, but not over tightened, or they will strip.**  
球頭鎖入塑膠件請務必注意，使用少量CA膠並適當扭力鎖緊即可，而過緊的扭力可能會導致滑牙。

**Apply a little amount of T43 thread lock when fixing a metal part.**  
螺絲鎖附於金屬件請使用適量T43(螺絲膠)

**Thrust bearing**  
止推軸承  
φ 6x φ 14x5mm

**Spindle bearing spacer**  
橫軸軸承墊片  
φ 10x φ 13.8x0.4mm

**Bearing MR148ZZ**  
MR148ZZ軸承  
φ 8x φ 14x4mm

**Main rotor holder**  
主旋翼夾座

**Linkage ball B(T2.6x5.5)**  
球頭B (T2.6x5.5)  
φ 4.75x12.27mm

## 50HH002

**Socket screw**  
圓頭內六角螺絲 (M4x10mm) x 2

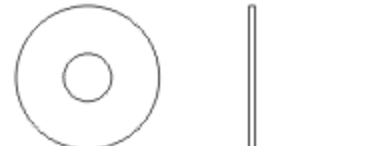

**Washer**  
橫軸華司 (φ 4x φ 12x1mm) x 2

**Damper rubber-gray 70°**  
橫軸墊圈 灰色70° (φ 7.9x φ 13x6.5mm) x 2

**Damper rubber-black 80°**  
橫軸墊圈 黑色80° (φ 7.9x φ 13x6.5mm) x 2

**Spacer**  
橫軸套圈 (φ 8x φ 11.5x1.3mm) x 2

**Metal main rotor housing**  
金屬主旋翼固定座

**Feathering shaft**  
橫軸  
φ 6x φ 8x93.2mm

**Apply grease**  
塗上潤滑油

**Damper rubber-gray 70° is suitable to general flight for beginners.**  
橫軸墊圈灰色70°適用於一般飛行，適合初階者使用  
**Damper rubber-black 80° is suitable to 3D flight for advanced users.**  
橫軸墊圈黑色80°適用於3D飛行，適合高階者使用

**Damper rubber**  
橫軸墊圈(橡膠)  
φ 7.9x φ 13x6.5mm

**Spacer (Copper)**  
橫軸套圈(銅)  
φ 8x φ 11.5x1.3mm

**Pin**  
定位插梢  
φ 2x32mm

**CAUTION**  
注意

**ALIGN logo on the top**  
字樣朝上















**Washer**  
橫軸華司  
φ 4x φ 12x1mm

**Socket screw**  
圓頭內六角螺絲  
M4x10mm

**Apply a little amount of T43 thread lock when fixing a metal part.**  
螺絲鎖附於金屬件請使用適量T43(螺絲膠)

# 50HH003

Apply a little amount of T43 thread lock when fixing a metal part.  
螺絲鎖附於金屬件請使用適量T43(螺絲膠)

-  **Linkage ball A(T2.6x3.5)**  
球頭A (T2.6x4.5)(φ4.75x8.18mm) x 2
-  **Linkage ball B(T2.6x5.5)**  
球頭B (T2.6x5.5)(φ4.75x12.27mm) x 2
-  **Self tapping screw**  
圓頭十字自攻螺絲(T3x14mm) x 2
-  **M3 collar screw**  
M3雙層軸套螺絲(M3x9.6mm) x 2
-  **Washer**  
華司(φ3xφ4.8x0.3mm) x 4
-  **Collar**  
擺臂軸承襯套(φ3xφ4.8x1.5mm) x 2
-  **Bearing 623ZZ**  
623ZZ軸承(φ3xφ10x4mm) x 2
-  **Bearing 683ZZ**  
683ZZ軸承(φ3xφ7x3mm) x 4
-  **Bearing MR74ZZ**  
MR74ZZ軸承(φ4xφ7x2.5mm) x 2
-  **M3 Set screw**  
M3止洩螺絲(M3x6mm) x 2
-  **M4 Set screw**  
M4止洩螺絲(M4x4mm) x 2
-  **Socket screw**  
圓頭內六角螺絲(M3x5mm) x 4
-  **Linkage rod(B)**  
連桿(B) φ2x19mm x 2
-  **Ball link**  
連桿頭 x 4

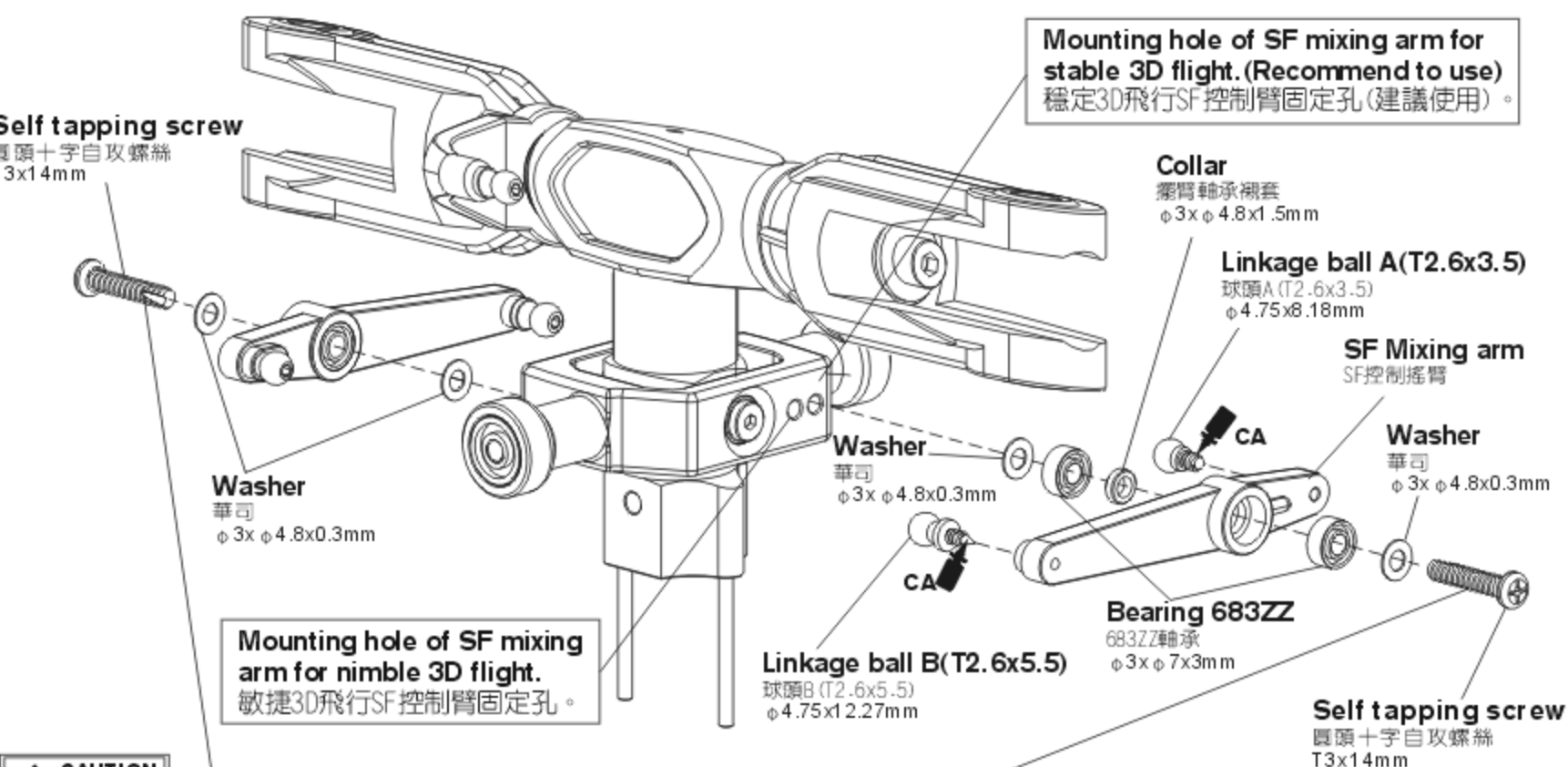
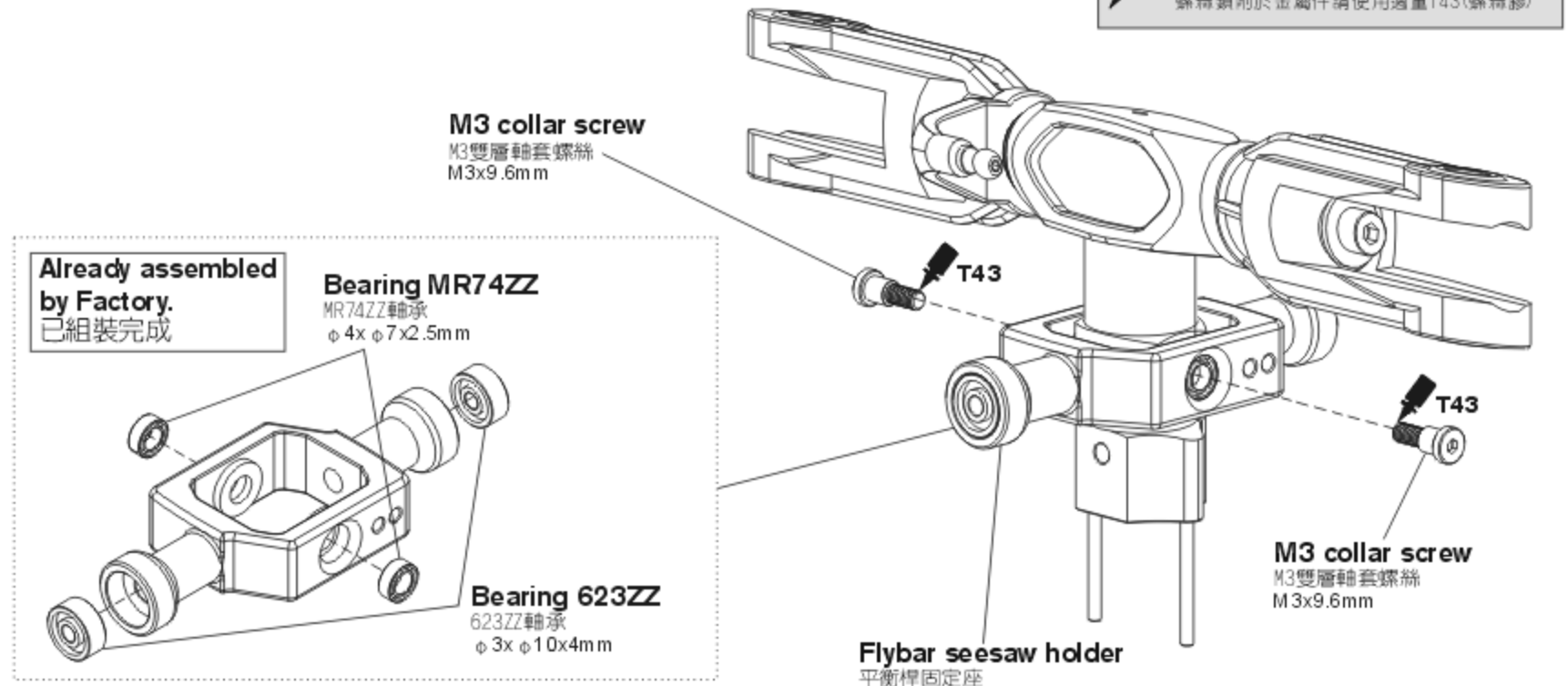

**CAUTION 注意**

When tightening a screw to a plastic part, please tighten it firmly, but not over tightened, or they will strip.  
螺絲鎖入塑膠件請務必注意，適當扭力鎖緊即可，而過緊的扭力可能會導致滑牙。

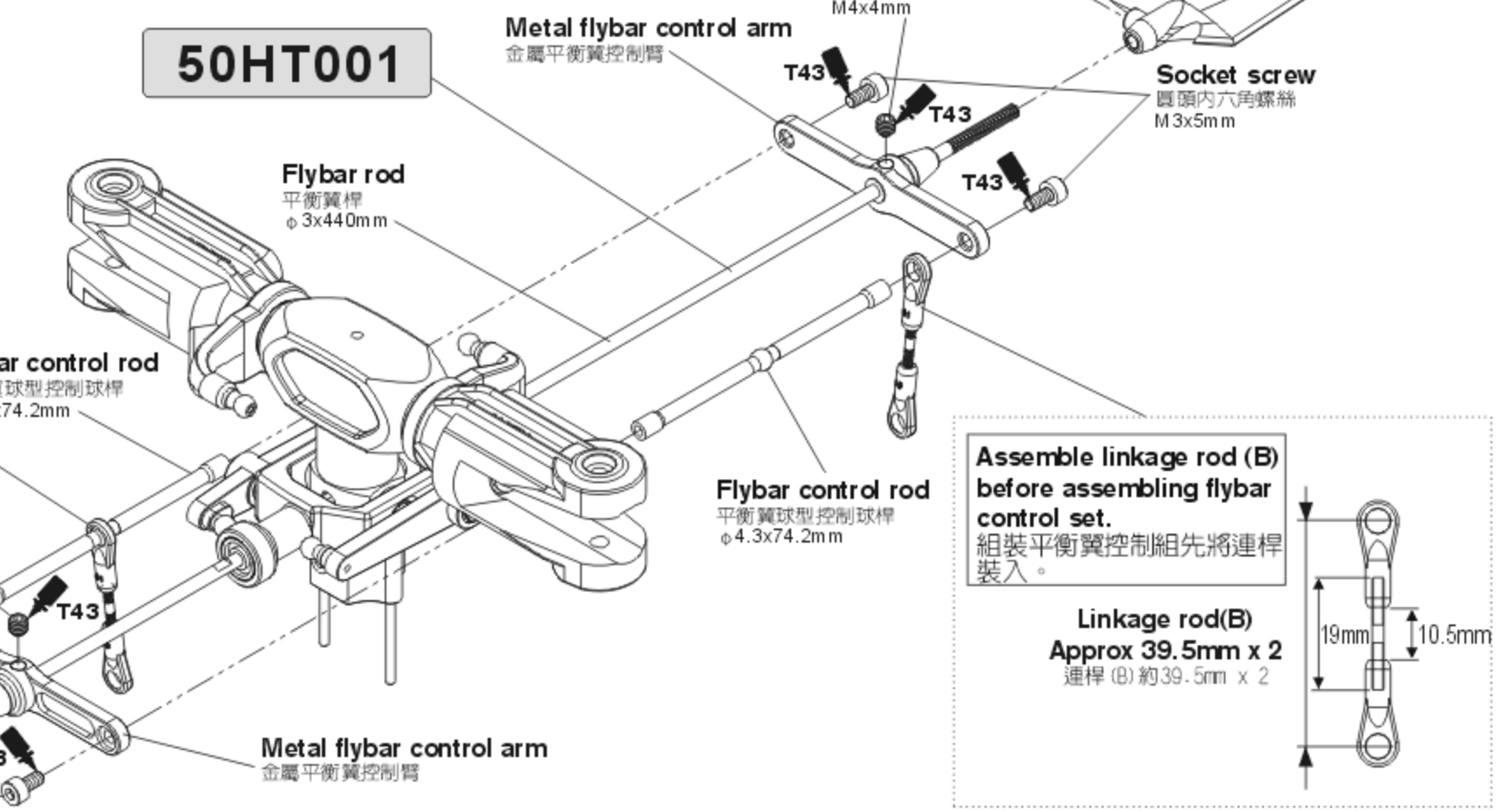

# 50HH004

**Apply a little amount of T43 thread lock when fixing a metal part.**  
 螺絲鎖附於金屬件請使用適量T43(螺絲膠)

- Linkage ball B(T2.6x5.5)**  
球頭B (T2.6x5.5) (φ4.75x12.27mm) x 2
- Bearing 683ZZ**  
683ZZ軸承 (φ3xφ7x3mm) x 4
- Collar screw**  
軸套螺絲(M2x12mm) x 2
- Socket screw**  
圓頭內六角螺絲(M3x12mm) x 2
- Washer**  
華司(φ3xφ4.8x0.3mm) x 2
- Collar**  
擺臂軸承襯套(φ3xφ4.8x1.5mm) x 2
- Collar**  
穩定控制搖臂鋼套(φ2xφ3x5.1mm) x 2
- Socket collar screw**  
圓頭內六角軸套螺絲(M3x22mm) x 1
- M3 Nut**  
M3防鬆螺帽 x 1

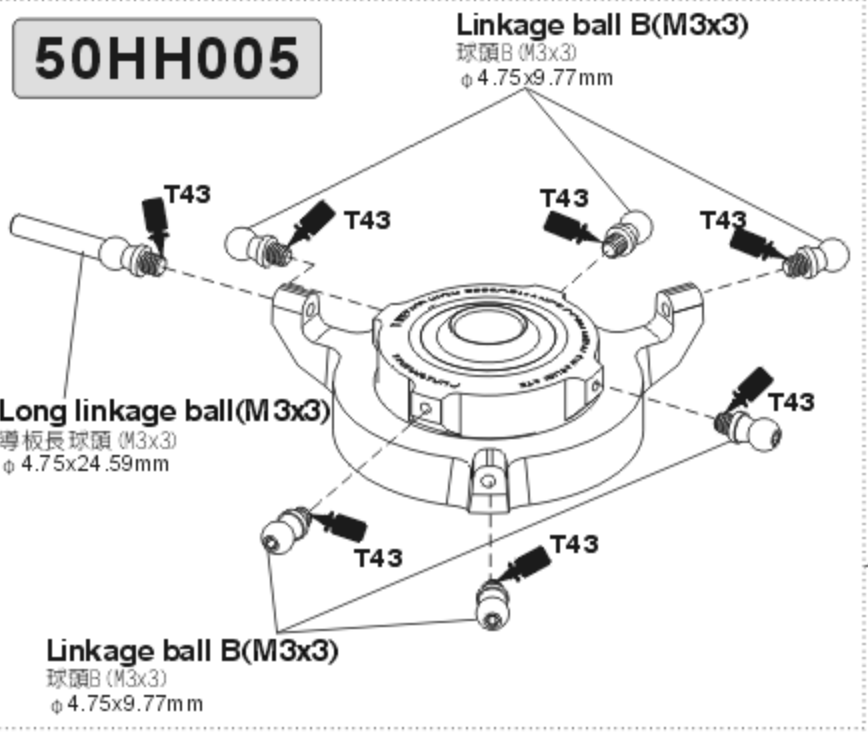
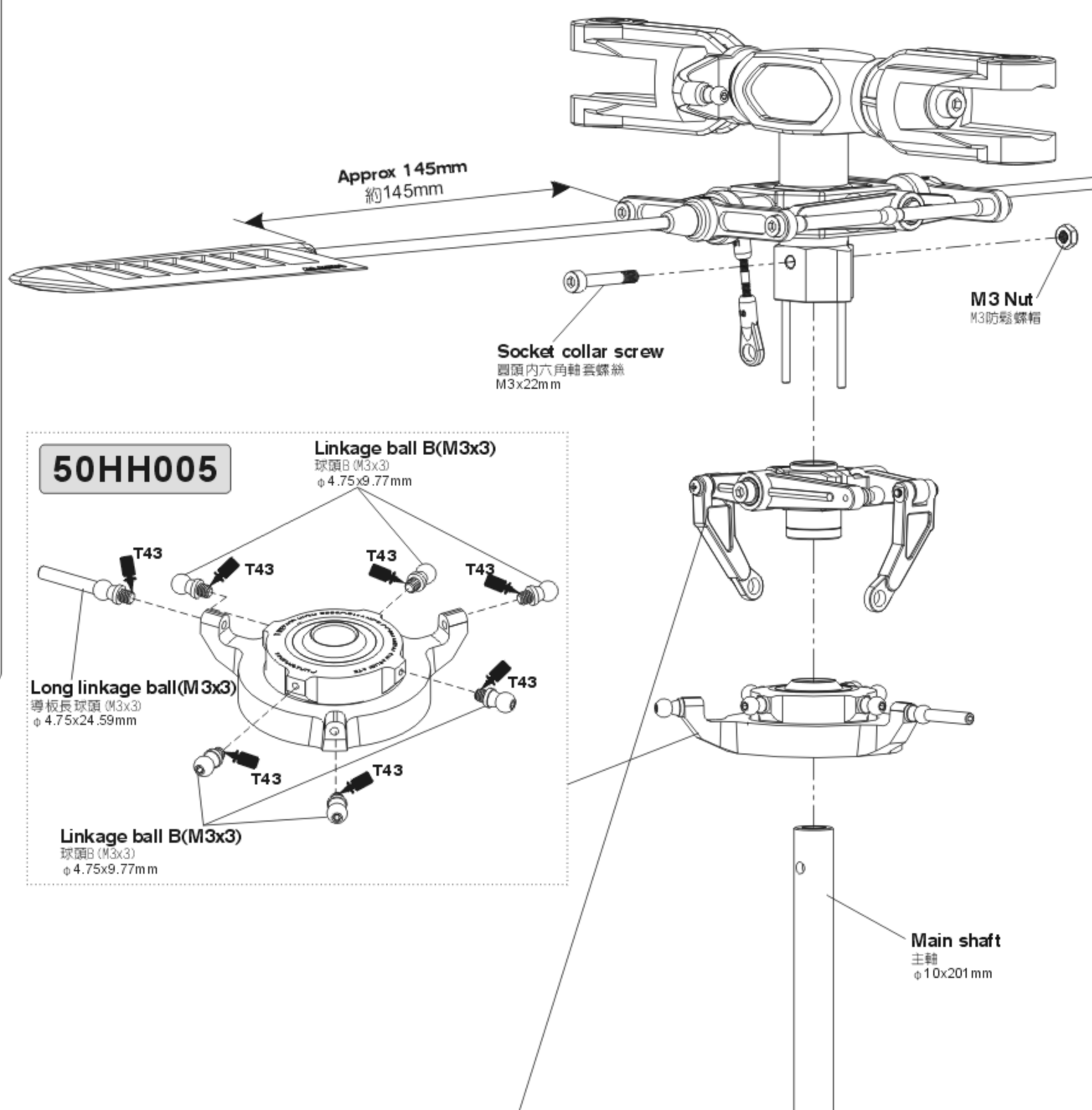

**CAUTION**  
注意

**Already assembled by Factory. Before flying, please check if the screws are fixed with glue.**  
 原裝組裝完成品，每一次飛行前請先確認螺絲是否已上膠不會鬆動。

**When tightening a linkage ball to a plastic part, please note to use a little CA glue and tighten it firmly, but not over tightened, or they will strip.**  
 球頭鎖入塑膠件請務必注意，使用少量CA膠並適當扭力鎖緊即可，而過緊的扭力可能會導致滑牙。

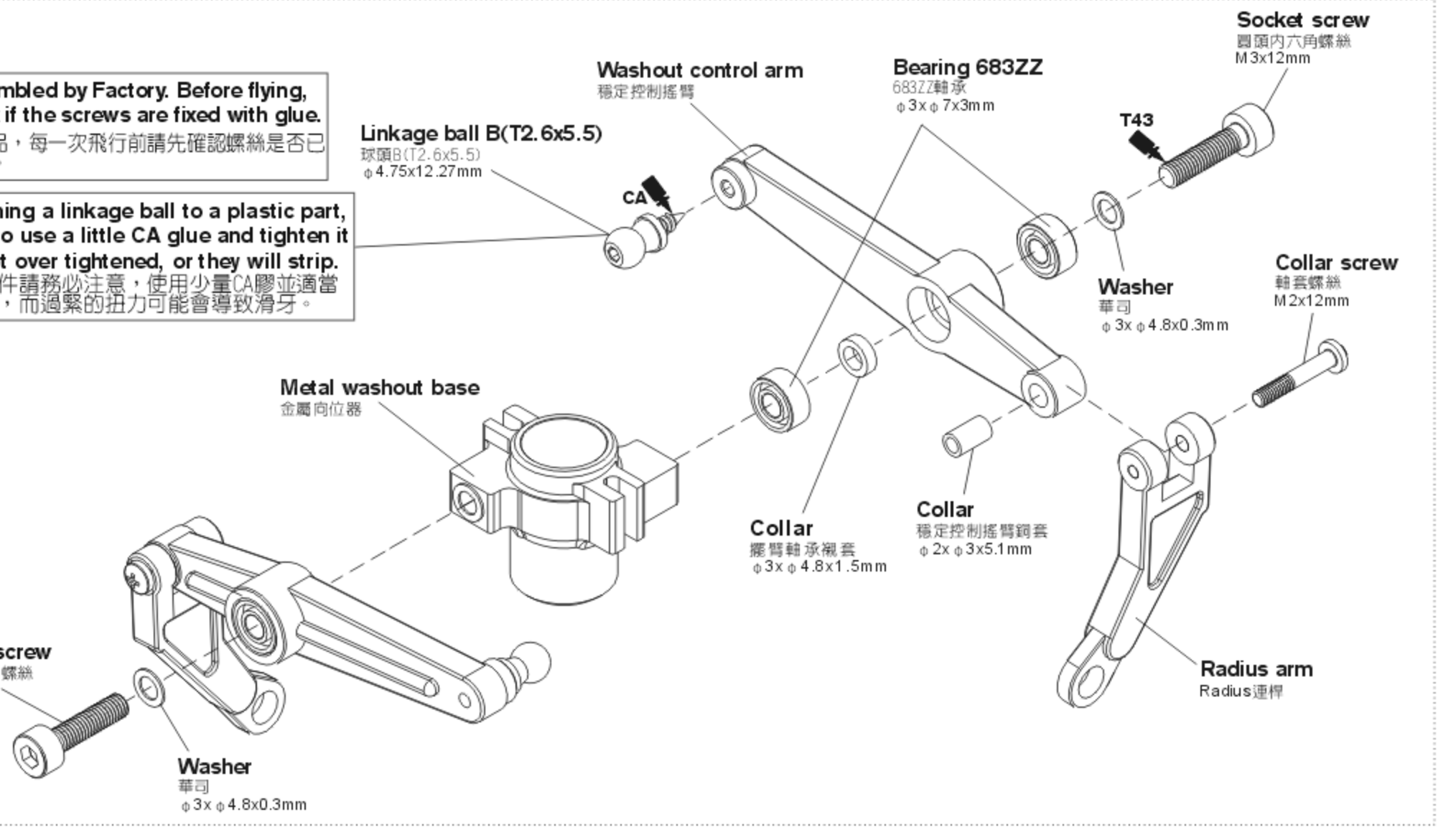

# 50HZ001



**Ball link**  
連桿頭 x 8



**Linkage rod(A)**  
連桿(A) φ2x14mm x 2



**Linkage rod(C)**  
連桿(C) φ2x48mm x 2

# 50HH002



**Socket screw**  
圓頭內六角螺絲(M3x10mm) x 1

Apply a little amount of T43 thread lock when fixing a metal part.  
螺絲鎖附於金屬件請使用適量T43(螺絲膠)

**Socket screw**  
圓頭內六角螺絲  
M3x10mm

**Metal head stopper**  
金屬旋翼頭制動器

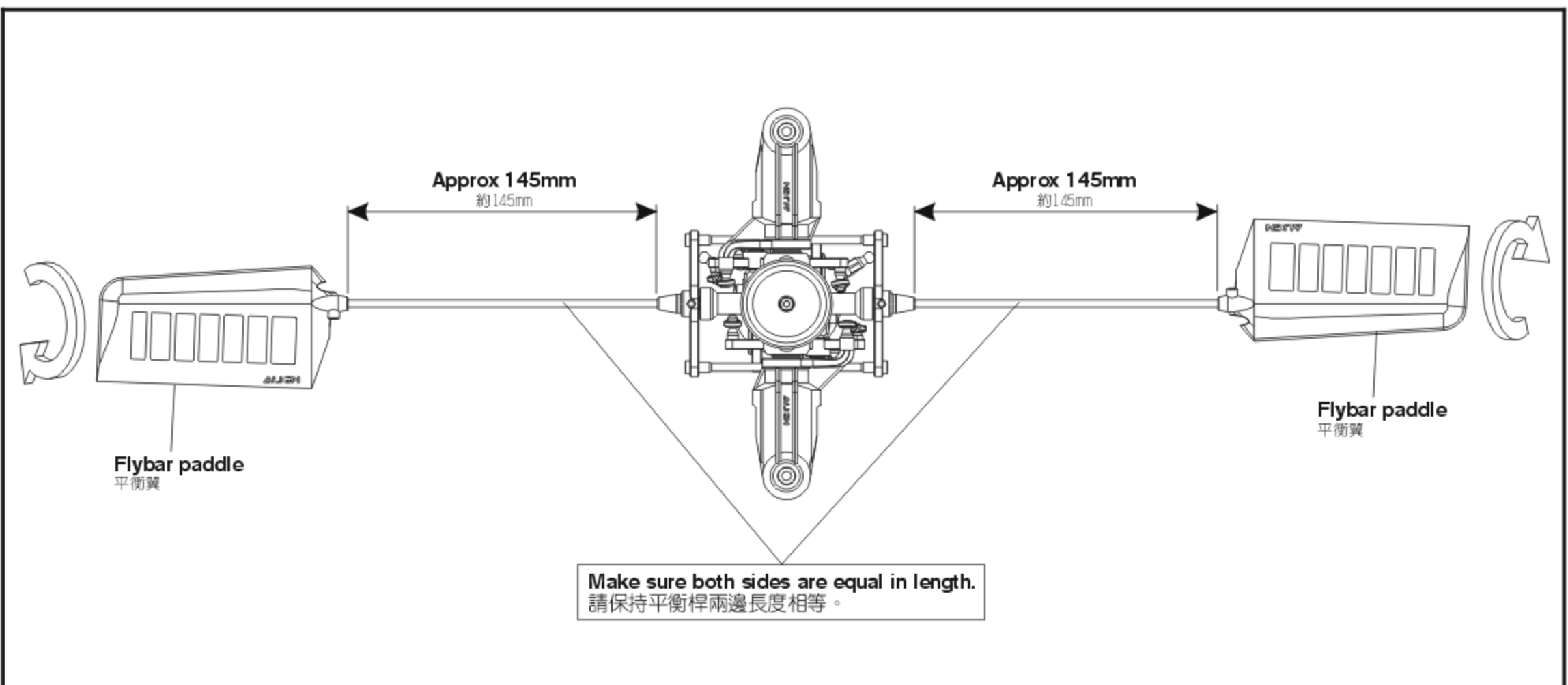
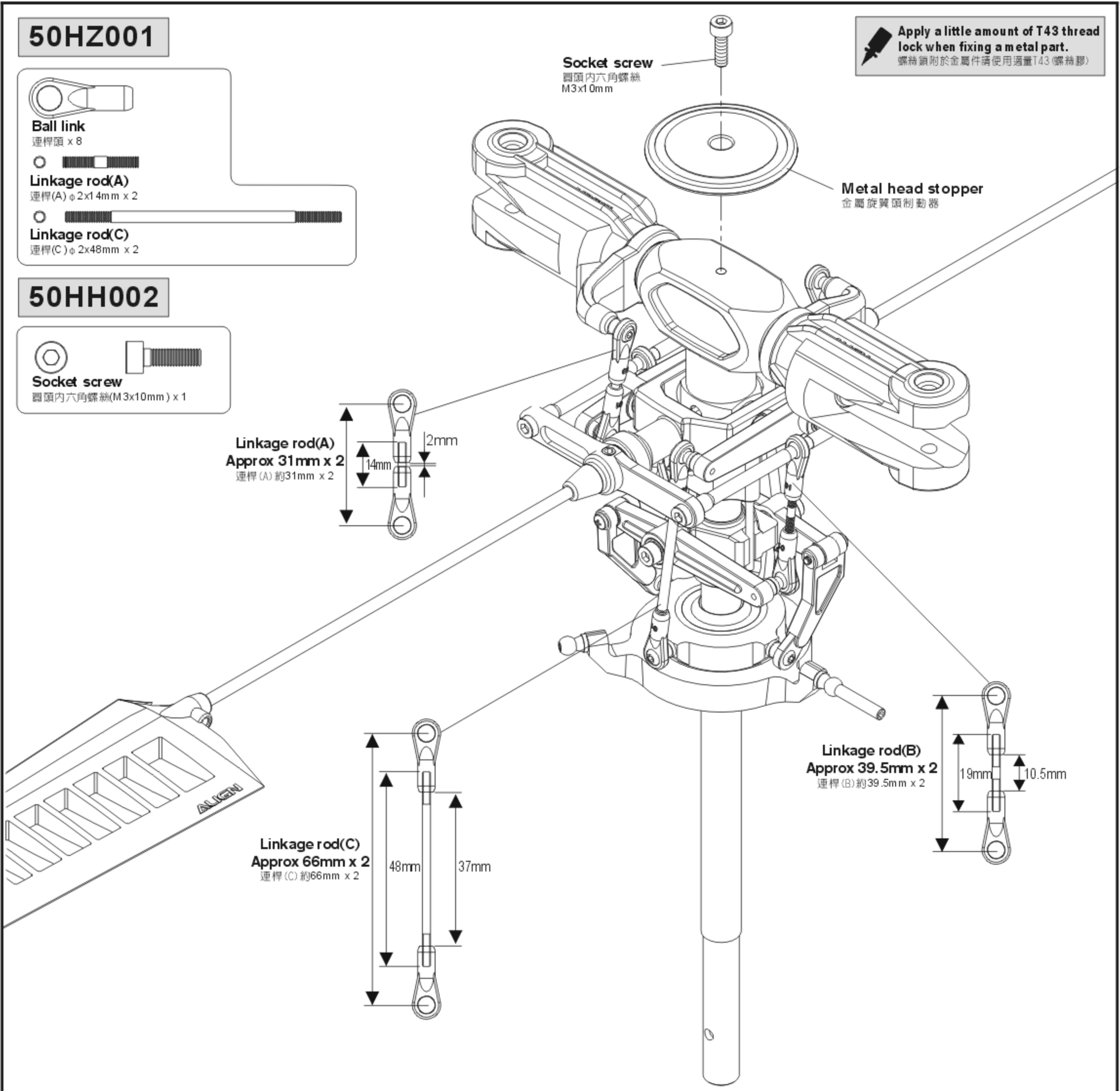



# 50HB001

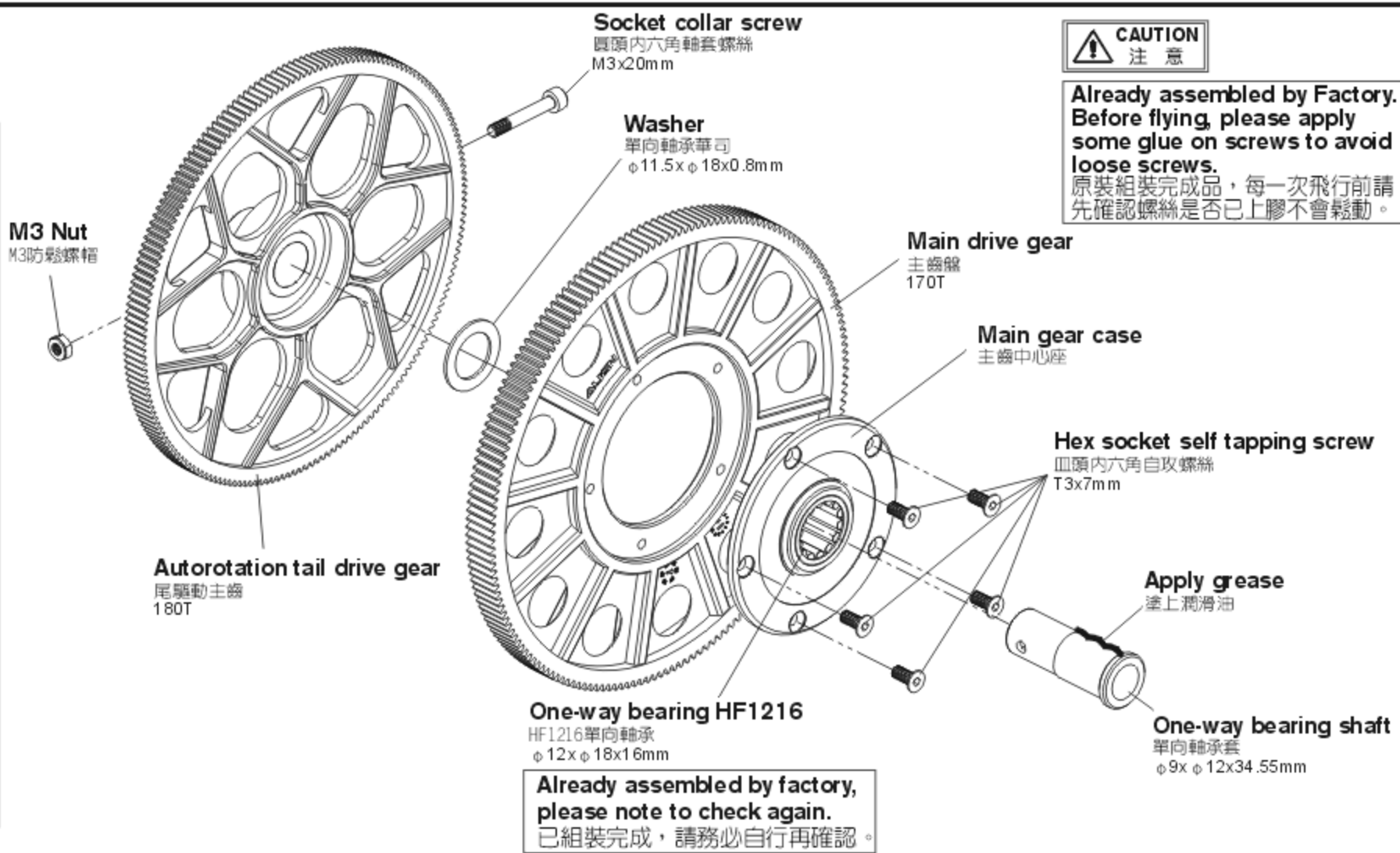
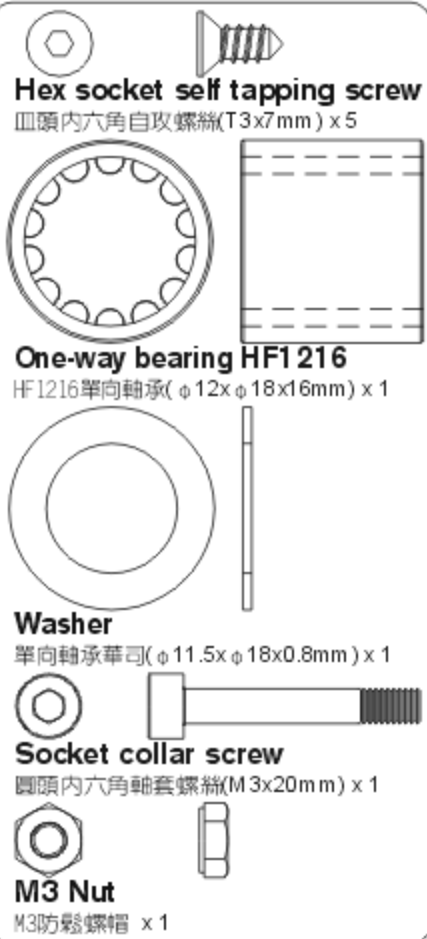

**CAUTION**  
注意

Already assembled by Factory. Before flying, please apply some glue on screws to avoid loose screws.  
原裝組裝完成品，每一次飛行前請先確認螺絲是否已上膠不會鬆動。

Already assembled by factory, please note to check again.  
已組裝完成，請務必自行再確認。

# 50HB002

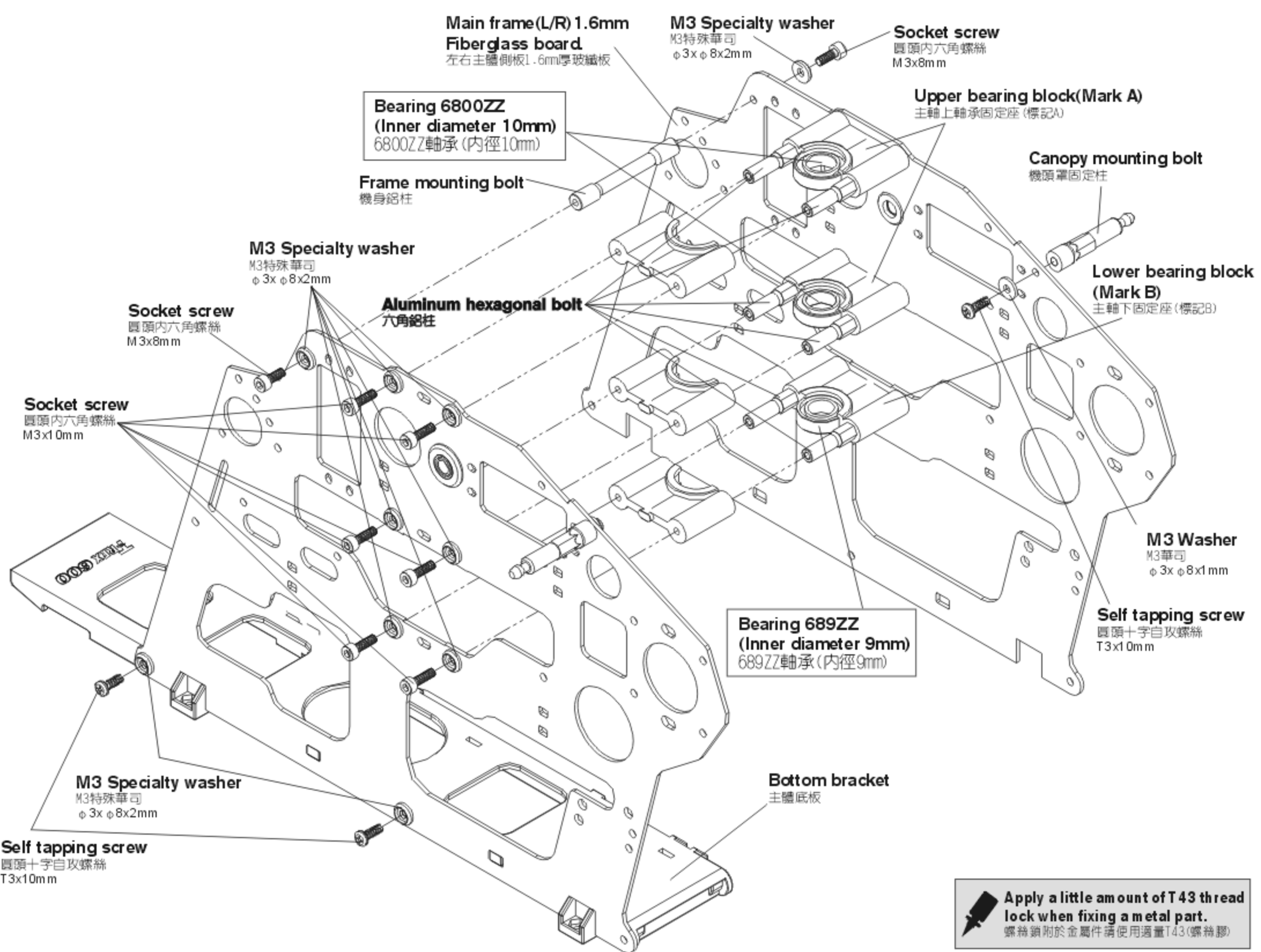
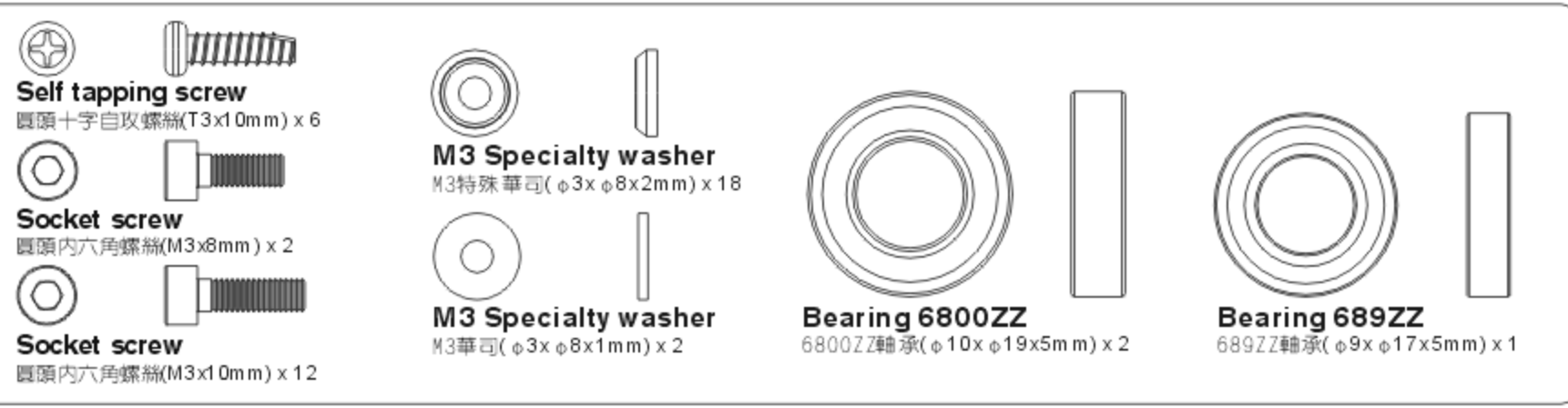

Apply a little amount of T43 thread lock when fixing a metal part.  
螺絲鎖附於金屬件請使用適量T43(螺絲膠)

**Assembly point:**

First do not fully tighten the screws of main frames and put three bearings through the main shaft to check if the movements are smooth. The bottom bracket must be firmly touched the level table top (glass surface); please keep the smooth movements on main shaft and level bottom bracket, then slowly tighten the screws. This assembly can help for the power and flight performance.

組立重點：  
側板螺絲先不完全鎖緊，放入主軸貫穿三顆軸承確認上下移動必需滑順，主體底板必須與水平桌面（玻璃平面）踏實緊貼；請保持主軸滑順與底板平行桌面後慢慢鎖緊螺絲。正確側板的組裝對動力與飛行性能有顯著幫助。

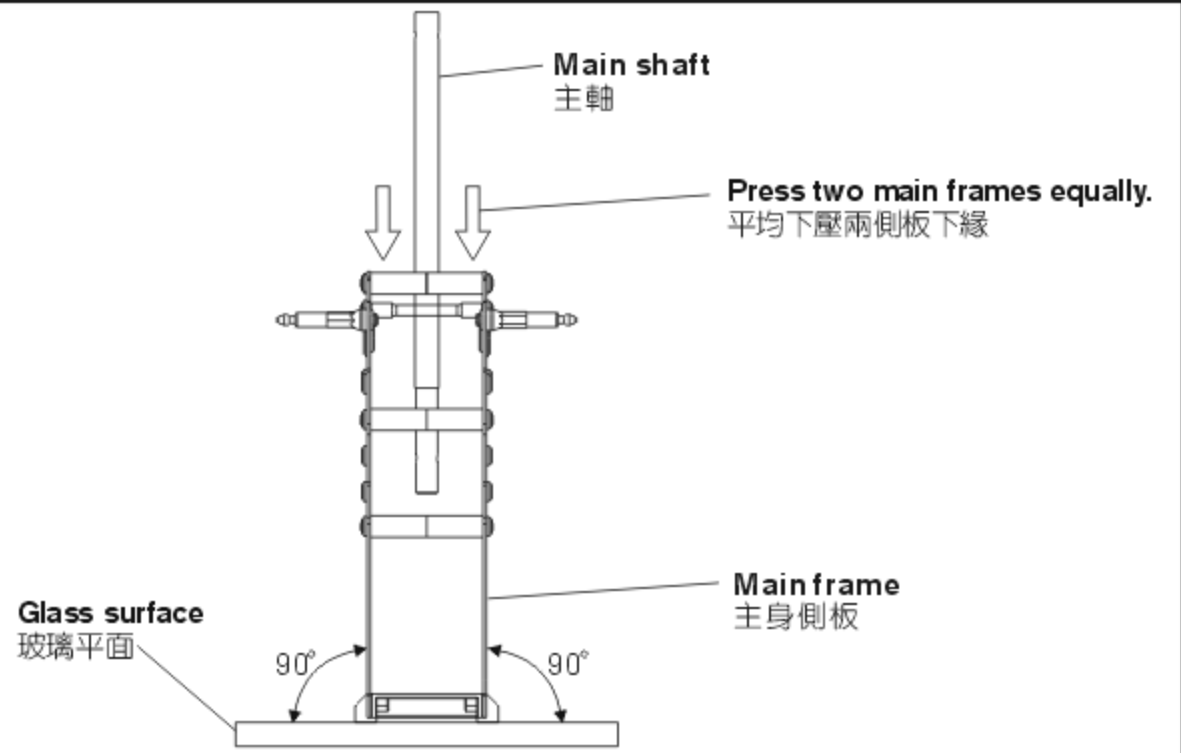

**50HB003**

**Socket screw**  
圓頭內六角螺絲(M 3x8mm) x 3

**M3 Nut**  
M3防鬆螺帽 x 3

**Bearing 684ZZ**  
684ZZ軸承(φ 4xφ 9x4mm) x 2

**Self tapping screw**  
圓頭十字自攻螺絲(T3x12mm) x 12

**M3 Specialty washer**  
M3特殊華司(φ 3xφ 8x2mm) x 12

Apply a little amount of T43 thread lock when fixing a metal part.  
螺絲鎖附於金屬件請使用適量T43(螺絲膠)

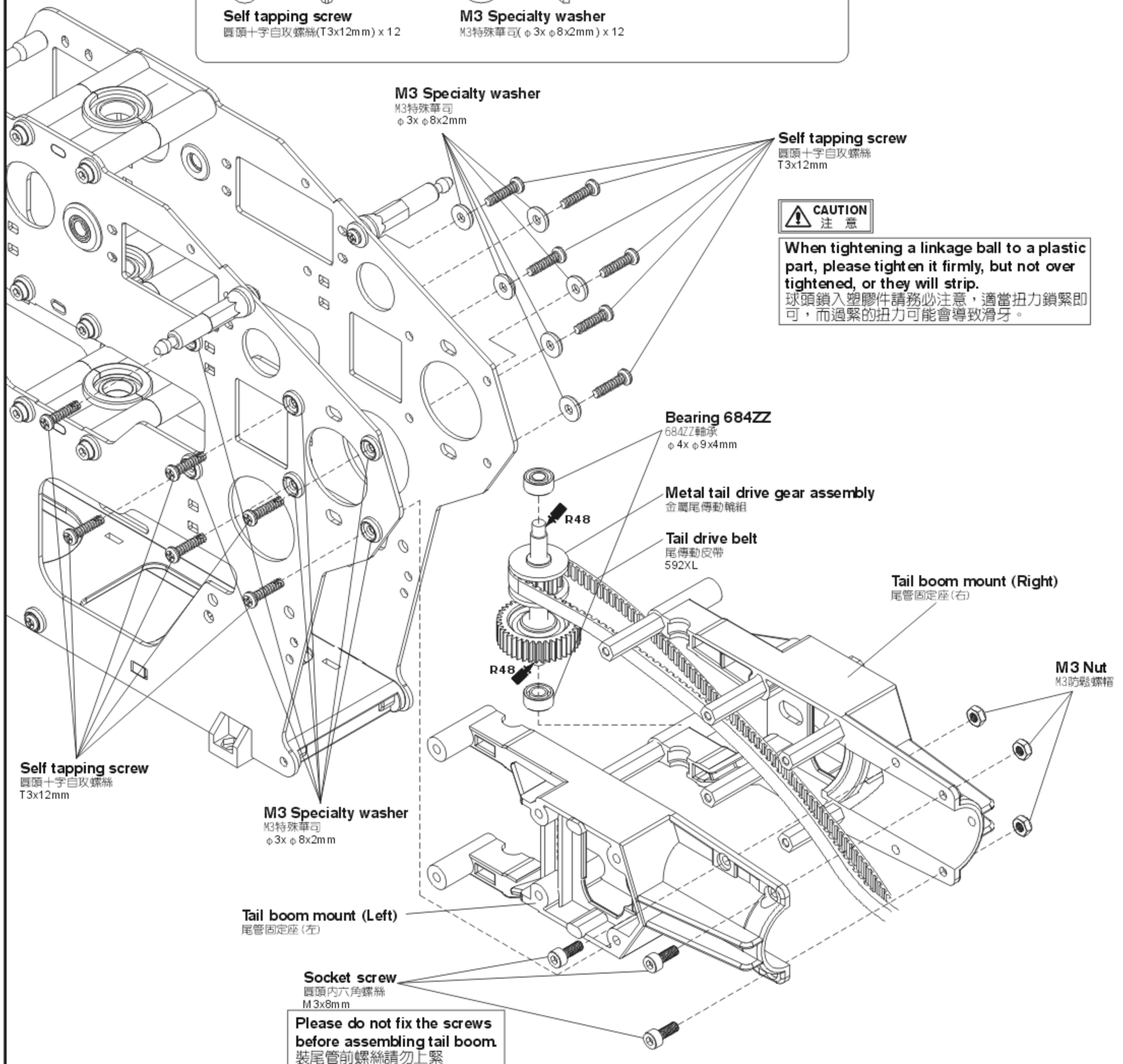

**CAUTION**  
注意

When tightening a linkage ball to a plastic part, please tighten it firmly, but not over tightened, or they will strip.  
球頭鎖入塑膠件請務必注意，適當扭力鎖緊即可，而過緊的扭力可能會導致滑牙。

Please do not fix the screws before assembling tail boom.  
裝尾管前螺絲請勿上緊

# 50HB004



**Self tapping screw**  
圓頭十字自攻螺絲(T3x8mm) x 6



**Socket screw**  
圓頭內六角螺絲(M3x6mm) x 4



**M3 Specialty washer**  
M3特殊華司(φ3xφ8x2mm) x 8



Apply a little amount of T43 thread lock when fixing a metal part.  
螺絲鎖附於金屬件請使用適量T43(螺絲膠)

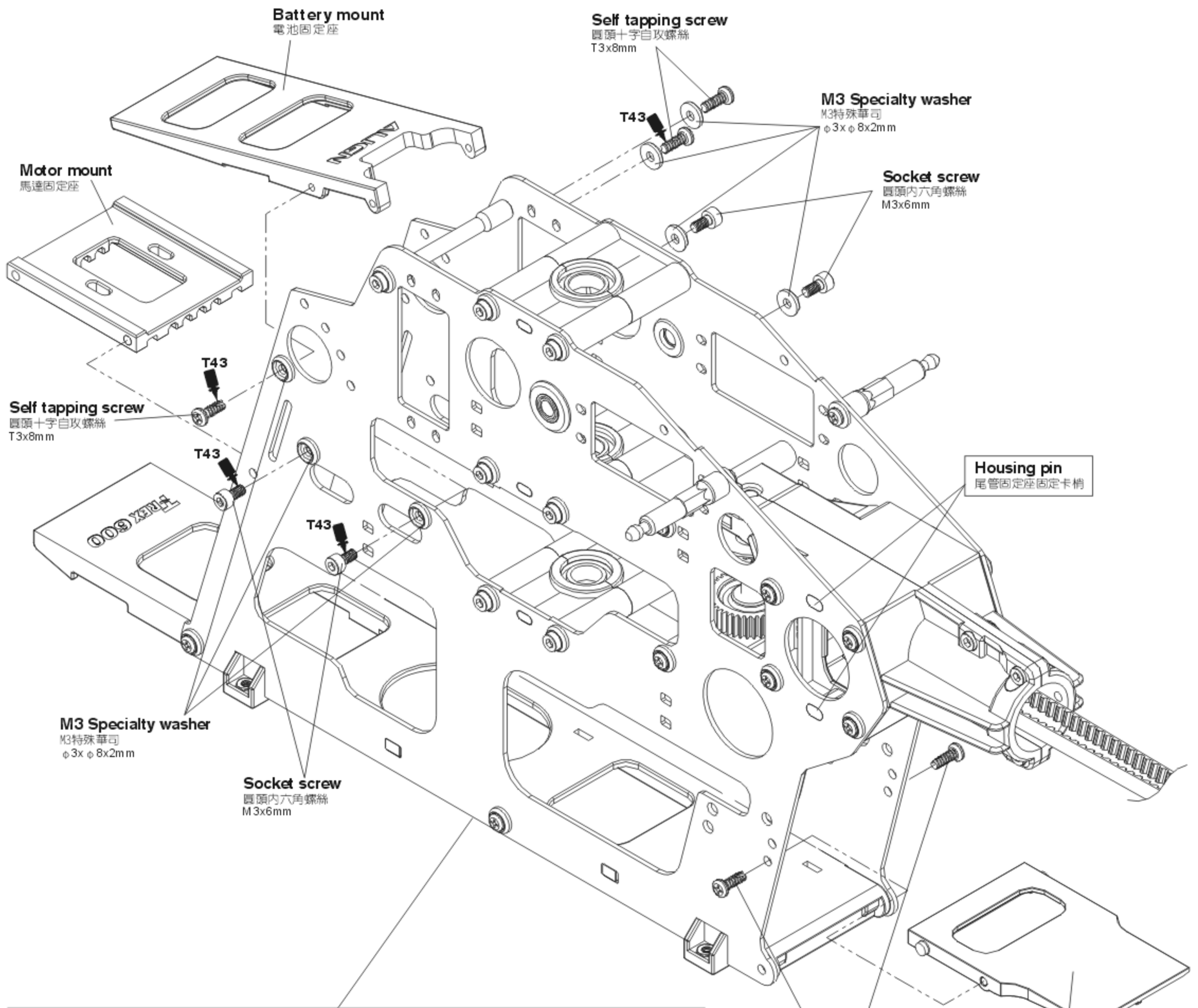

Recommend sanding the marked position as below illustration with a waterproof abrasive paper (#800-1000) to avoid the wires of electric parts to be cut.  
建議於下圖色塊標示處，可使用#800-1000水砂紙打磨，可防止電子設備電線被割破。

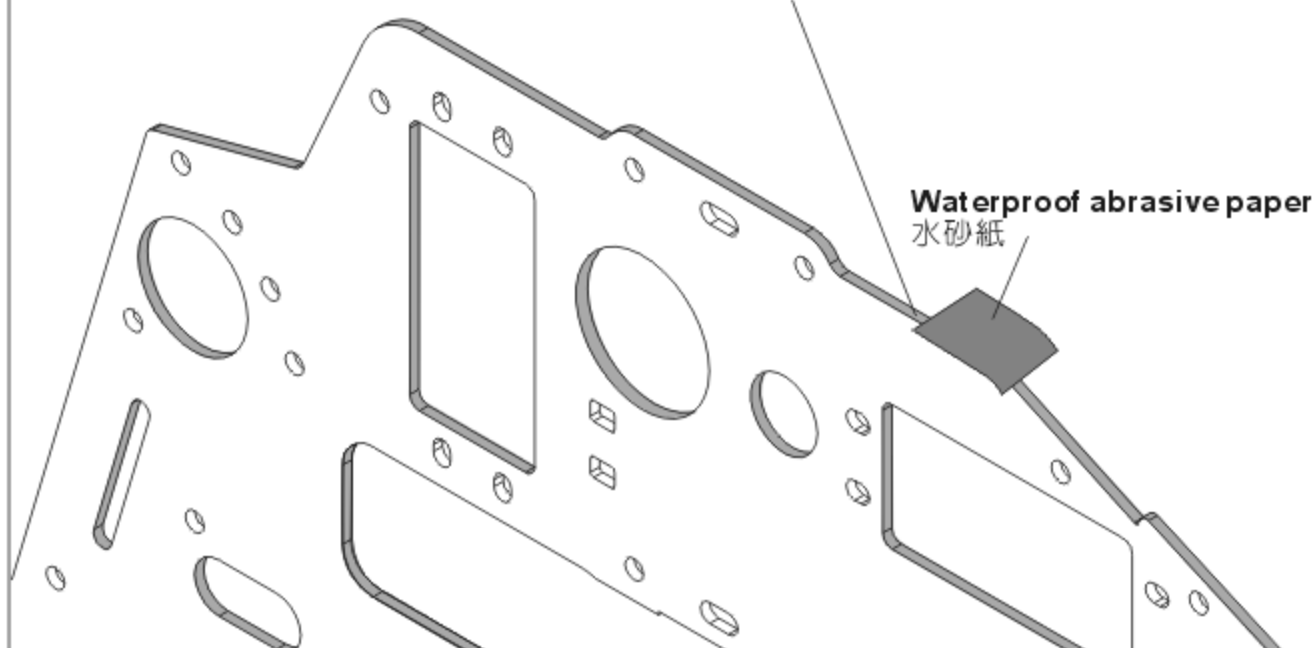

# 50HB004

**Linkage ball A(T2.6x3.5)**  
球頭A(T2.6x3.5)( $\phi 4.75 \times 8.68\text{mm}$ ) x 9

**Self tapping screw**  
圓頭十字自攻螺絲(T3x8mm) x 2

**Socket screw**  
圓頭內六角螺絲(M3x6mm) x 2

**M4 Set screw**  
M4止洩螺絲(M4x4mm) x 1

**Washer**  
華可( $\phi 5 \times \phi 7 \times 0.5\text{mm}$ ) x 2

**Washer**  
華可( $\phi 5 \times \phi 7 \times 0.2\text{mm}$ ) x 2

**Washer**  
華可( $\phi 3 \times \phi 5.5 \times 0.3\text{mm}$ ) x 2

**M3 Specialty washer**  
M3特殊華可( $\phi 3 \times \phi 8 \times 2\text{mm}$ ) x 2



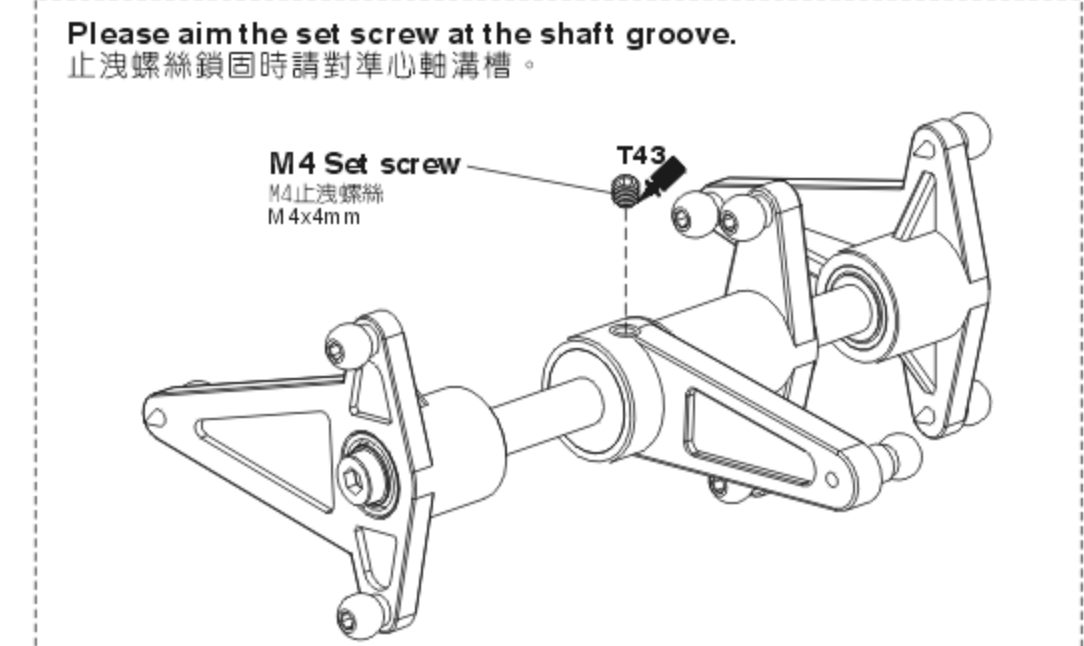
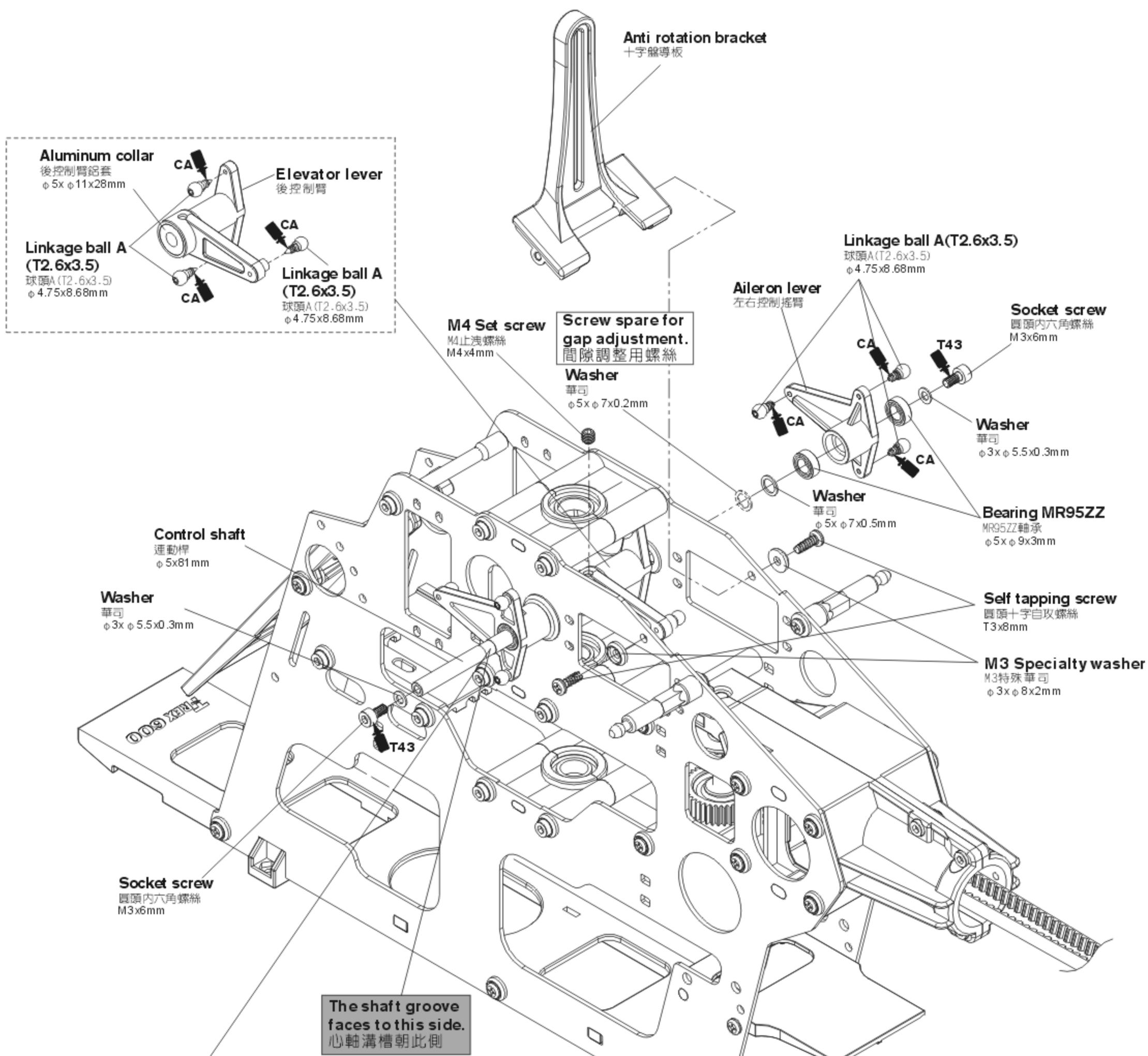





**Bearing MR95ZZ**  
MR95ZZ軸承( $\phi 5 \times \phi 9 \times 3\text{mm}$ ) x 4



**Apply a little amount of T43 thread lock when fixing a metal part.**  
螺絲鎖附於金屬件請使用適量T43(螺絲膠)

# 50HB005

Apply a little amount of T43 thread lock when fixing a metal part.  
 螺絲鎖附於金屬件請使用適量T43(螺絲膠)

-    
**Socket screw**  
 圓頭內六角螺絲(M3x12mm) x 4
-    
**M3 Set screw**  
 M3止洩螺絲(M3x4mm) x 4
-    
**M3 Nut**  
 M3防鬆螺帽 x 4
-    
**M3 Washer**  
 M3華司(φ3xφ8x1mm) x 4

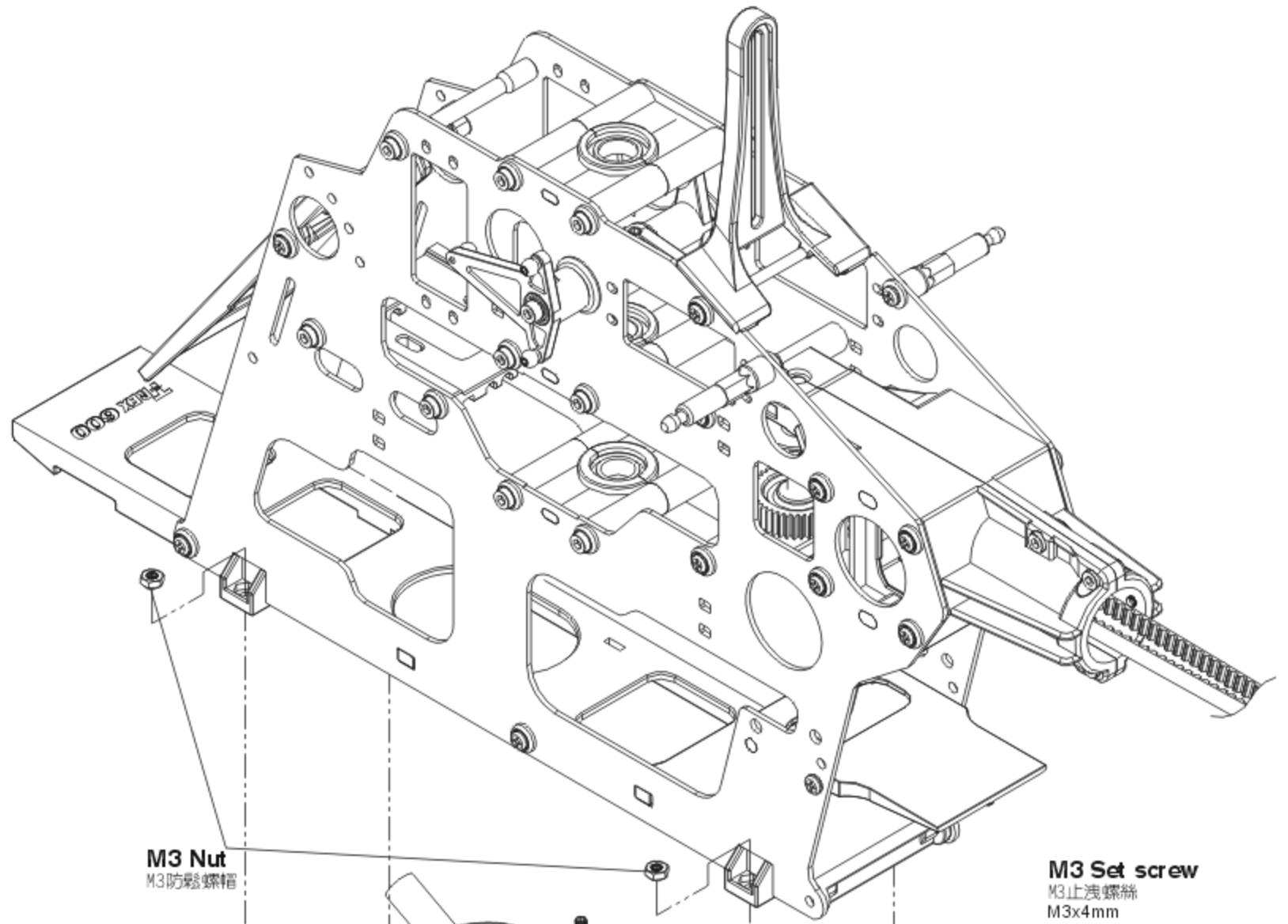

**M3 Nut**  
 M3防鬆螺帽

**M3 Set screw**  
 M3止洩螺絲  
 M3x4mm

**3D landing skid(white)**  
 3D腳架(白色)

**Skid pipe end cap**  
 腳架鋁管保護套

**M3 Set screw**  
 M3止洩螺絲  
 M3x4mm

**M3 Washer**  
 M3華司  
 φ3xφ8x1mm

**Landing skid nut**  
 腳架墊圈

**Socket screw**  
 圓頭內六角螺絲  
 M3x12mm

**M3 Set screw**  
 M3止洩螺絲  
 M3x4mm

**M3 Washer**  
 M3華司  
 φ3xφ8x1mm

**Antenna pipe**  
 天線管  
 φ2xφ4x500mm

**Socket screw**  
 圓頭內六角螺絲  
 M3x12mm

**Skid pipe**  
 腳架鋁管  
 φ9x310mm

**Landing skid nut**  
 腳架墊圈

**Skid pipe end cap**  
 腳架鋁管保護套

# 50HT001

# 50HT002

- Self tapping screw**  
圓頭十字自攻螺絲(T3x12mm) x 2
- M3 Washer**  
M3華司(φ3xφ8x1mm) x 2
- Socket button head screw**  
半圓頭內六角螺絲(M3x5mm) x 1

Rudder servo mount  
尾舵伺服器固定座

Apply a little amount of T43 thread lock when fixing a metal part.  
螺絲鎖附於金屬件請使用適量T43(螺絲膠)

# 50HT001

M3 Washer  
M3華司  
φ3xφ8x1mm

Self tapping screw  
圓頭十字自攻螺絲  
T3x12mm

Rudder servo bracket  
尾舵伺服器板

Tail control guide  
尾控制桿固定環

Please check if firmly tighten after assembling the tail boom.  
裝入尾管後請確實上緊

**CAUTION**  
注意

Aim the opening of tail boom at the convex of the case and insert.  
瞄準尾管上的凹槽和尾座凸出，並插入。

Please insert the opening of tail boom into the convex.  
尾管缺口方向裝入時，請導入尾管座卡榫內。

Tail boom  
尾管  
625mm

Socket button head screw  
半圓頭內六角螺絲  
M3x5mm

Tail boom fixing screw  
尾管固定螺絲

**CAUTION**  
注意

### Drive belt illustration 尾傳動皮帶裝配圖示

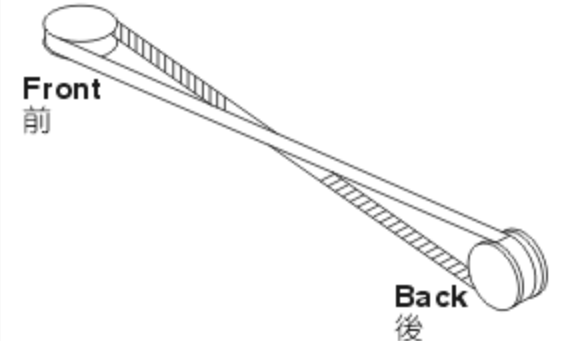

1. Check to rotate the belt 90 degrees when assembling.
  2. Belt tension: Recommend to lightly tighten the drive belt after assembling tail boom to avoid vibration, belt friction and rotation slip.
1. 組裝時確認皮帶順轉90°。  
2. 皮帶緊度：建議尾管組裝後皮帶請稍微拉緊，避免震動皮帶摩擦或轉動打滑。

Use the strap to fix tail control guides.  
尾控制連桿固定環可使用隨附束帶固定。

Cut to trim the length by a knife.  
可用刀子裁切做長度修整。

Approx 220mm  
約220mm

Approx 180mm  
約180mm

# 600NT2H

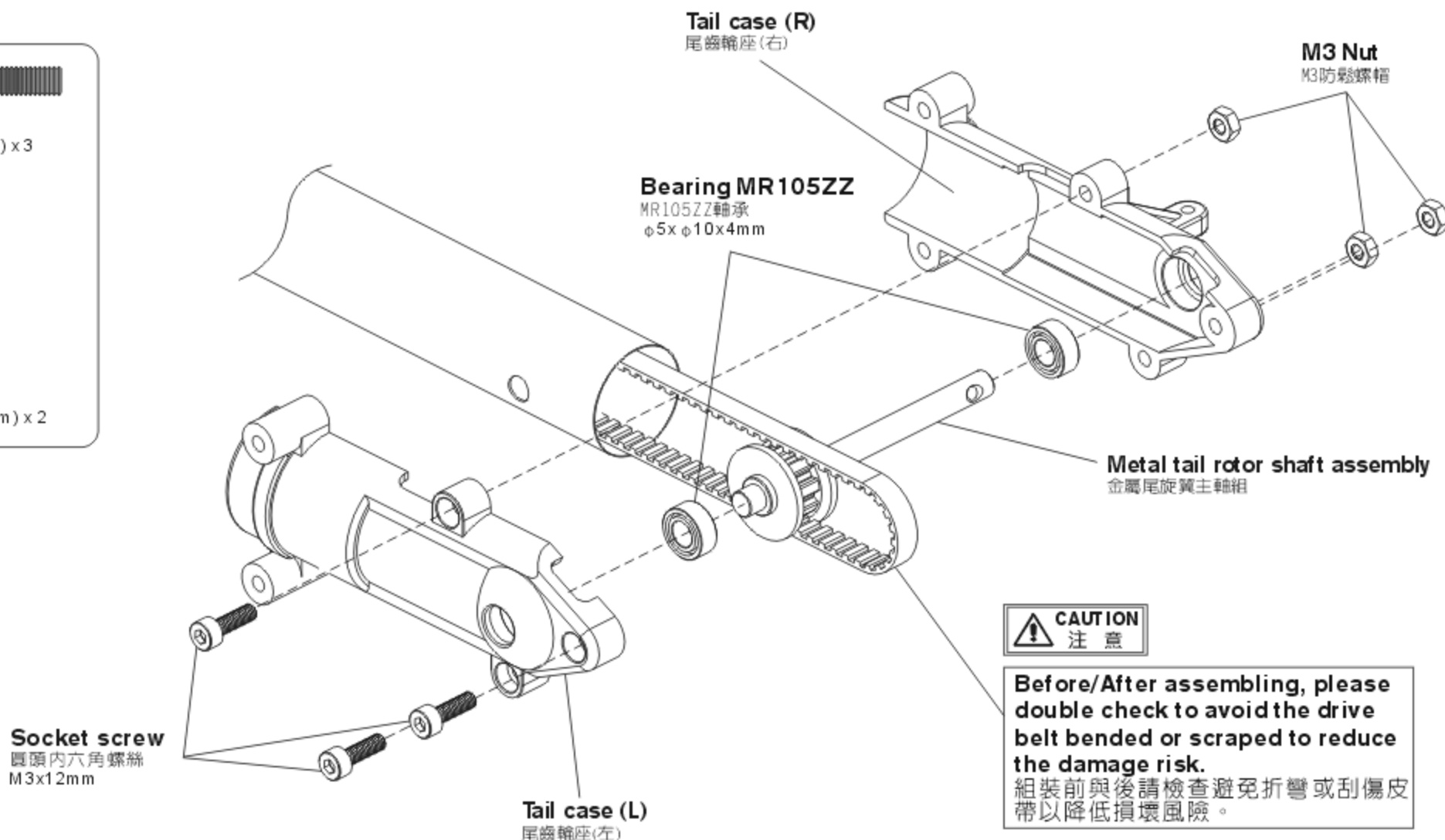
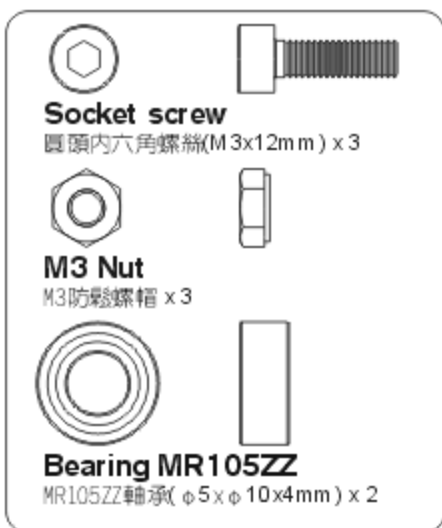

# 600NT2B

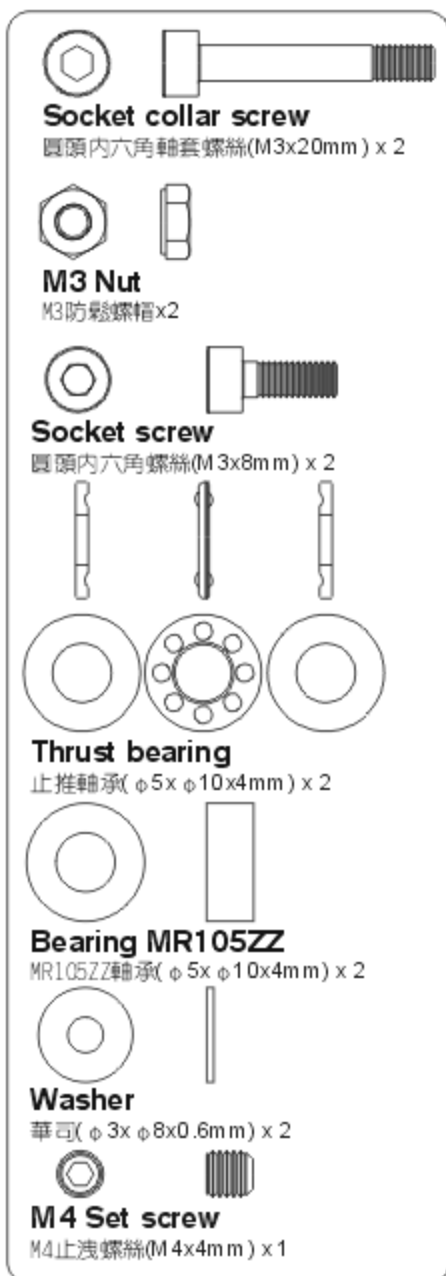

**3K CF Tail blade**  
3K碳纖尾旋翼

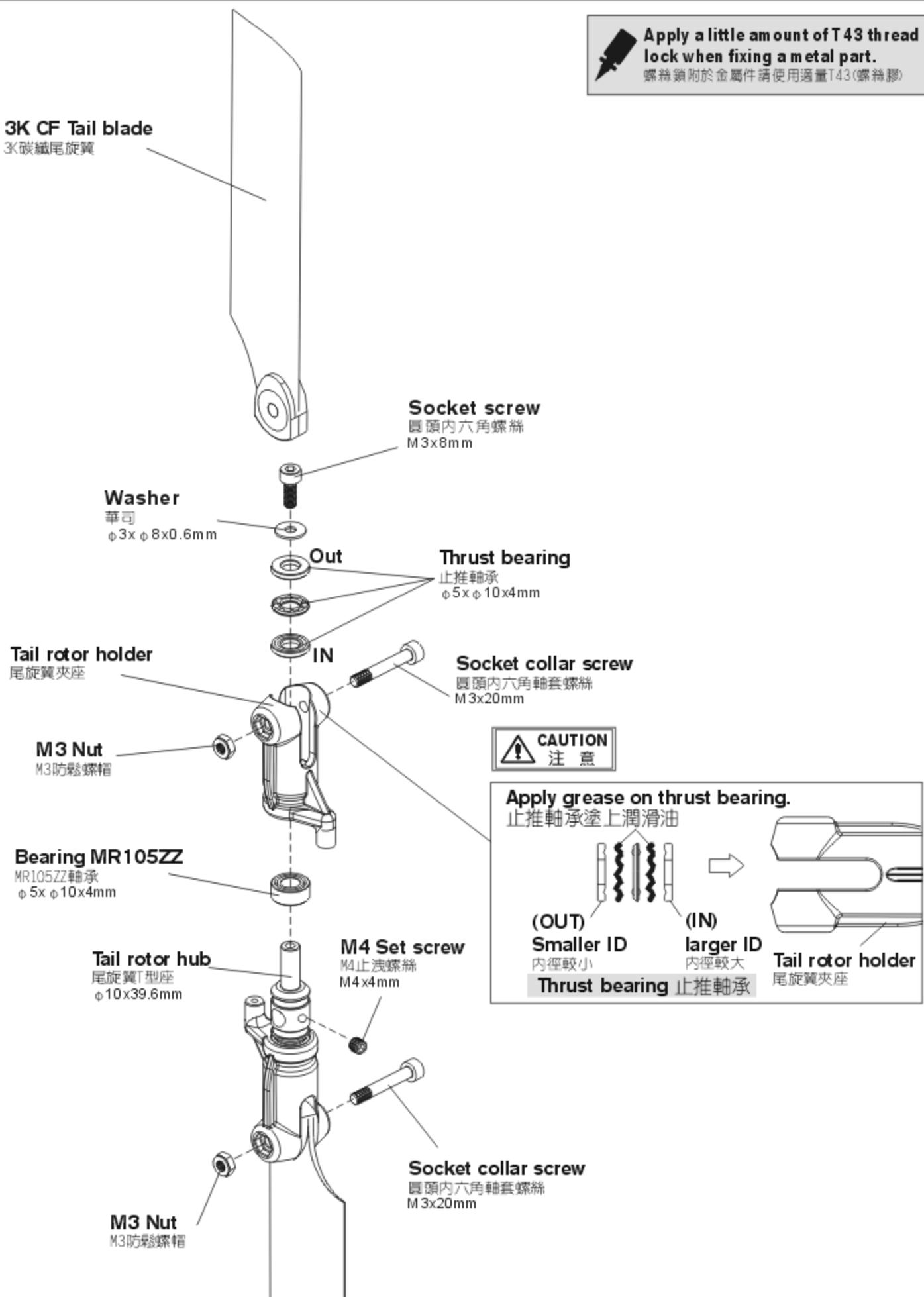

**CAUTION 注意**  
Already assembled by Factory. Before flying, please apply some glue on screws to avoid loose screws.  
原裝組裝完成品，每一次飛行前請先確認螺絲是否已上膠不會鬆動。

# 50HT005

- Linkage ball A (T2.6x3.5)**  
球頭A (T2.6x3.5) (φ 4.75x8.18mm) x 1
- Socket collar screw**  
圓頭內六角軸套螺絲 (M3x15mm) x 1
- Washer**  
華司 (φ 3x φ 4.8x0.3mm) x 2

# 50HT006

- Collar screw**  
軸套螺絲 (M2x8mm) x 4
- Collar A**  
尾連桿頭銅套A (φ 2x φ 3x4mm) x 2
- Collar B**  
尾連桿頭銅套B (φ 2x φ 3x3mm) x 2



**Aim tail rotor hub at the concave of tail rotor shaft and fix it, please apply a little glue on the set screw.**  
尾旋翼T型座瞄準尾橫軸的凹刻並鎖上，請確認止洩螺絲上膠。

**Already assembled by factory, please note to check again.**  
已組裝完成，請務必自行再確認。  
**Tail pitch assembly**  
尾旋翼控制組

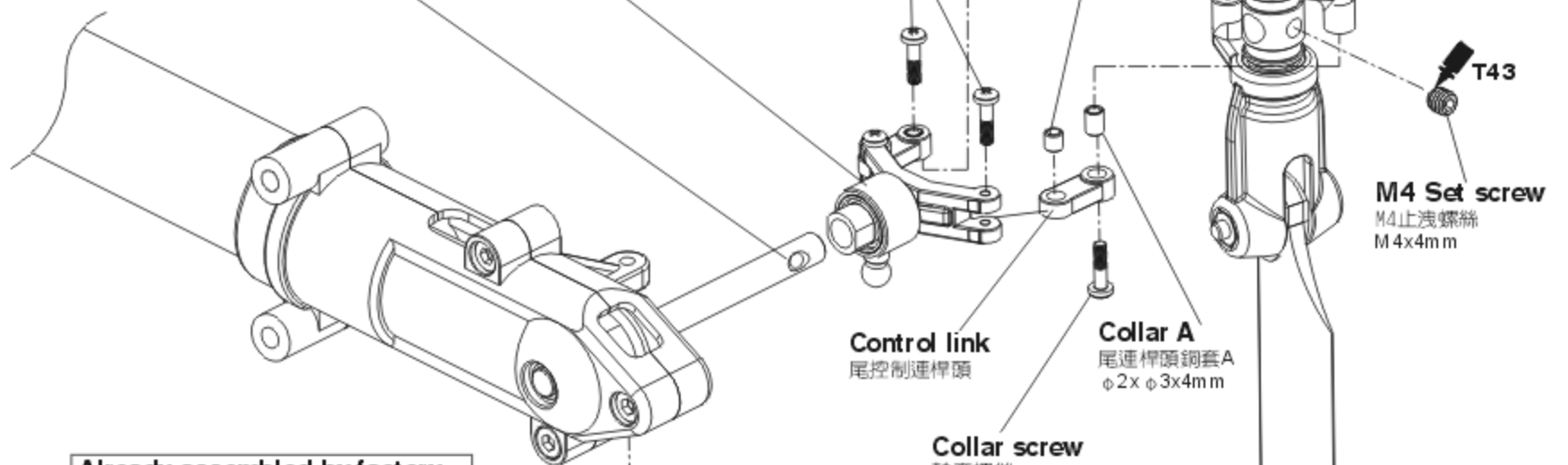

**Already assembled by factory, please note to check again.**  
已組裝完成，請務必自行再確認。  
**Tail rotor control arm**  
尾旋翼控制臂

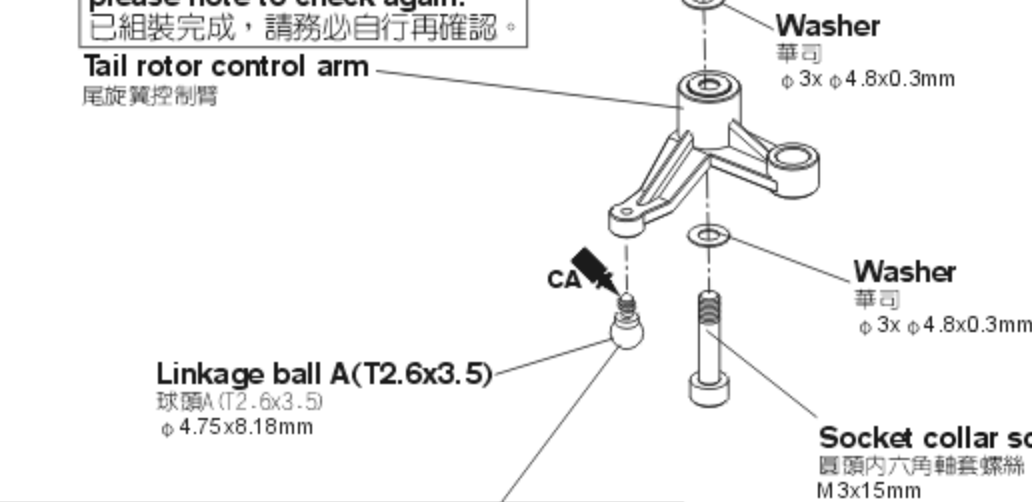

**When tightening a linkage ball to a plastic part, please note to use a little CA glue and tighten it firmly, but not over tightened, or they will strip.**  
球頭鎖入塑膠件請務必注意，使用少量CA膠並適當扭力鎖緊即可，而過緊的扭力可能會導致滑牙。

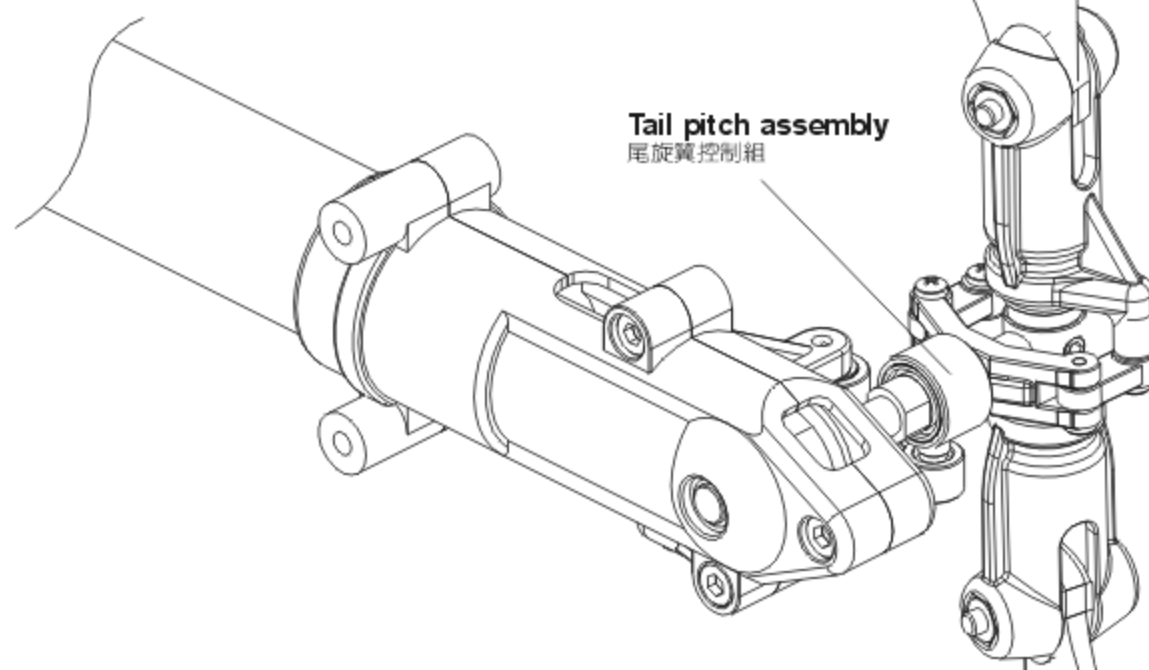

**Apply a little amount of T43 thread lock when fixing a metal part.**  
螺絲鎖劑於金屬件請使用適量T43(螺絲膠)



# 50HT007

# 50HT008

Apply a little amount of T43 thread lock when fixing a metal part.  
螺絲鎖附於金屬件請使用適量T43(螺絲膠)

**Socket screw**  
圓頭內六角螺絲(M3x26mm) x 2

**Self tapping screw**  
圓頭十字自攻螺絲(T3x14mm) x 2

**M3 Nut**  
M3防鬆螺帽 x 2

**M3 Washer**  
M3華司(φ3xφ8x1mm) x 4

**Self tapping screw**  
圓頭十字自攻螺絲(T3x12mm) x 2

**Self tapping screw**  
圓頭十字自攻螺絲(T3x10mm) x 2

**M3 Washer**  
M3華司(φ3xφ8x1mm) x 4

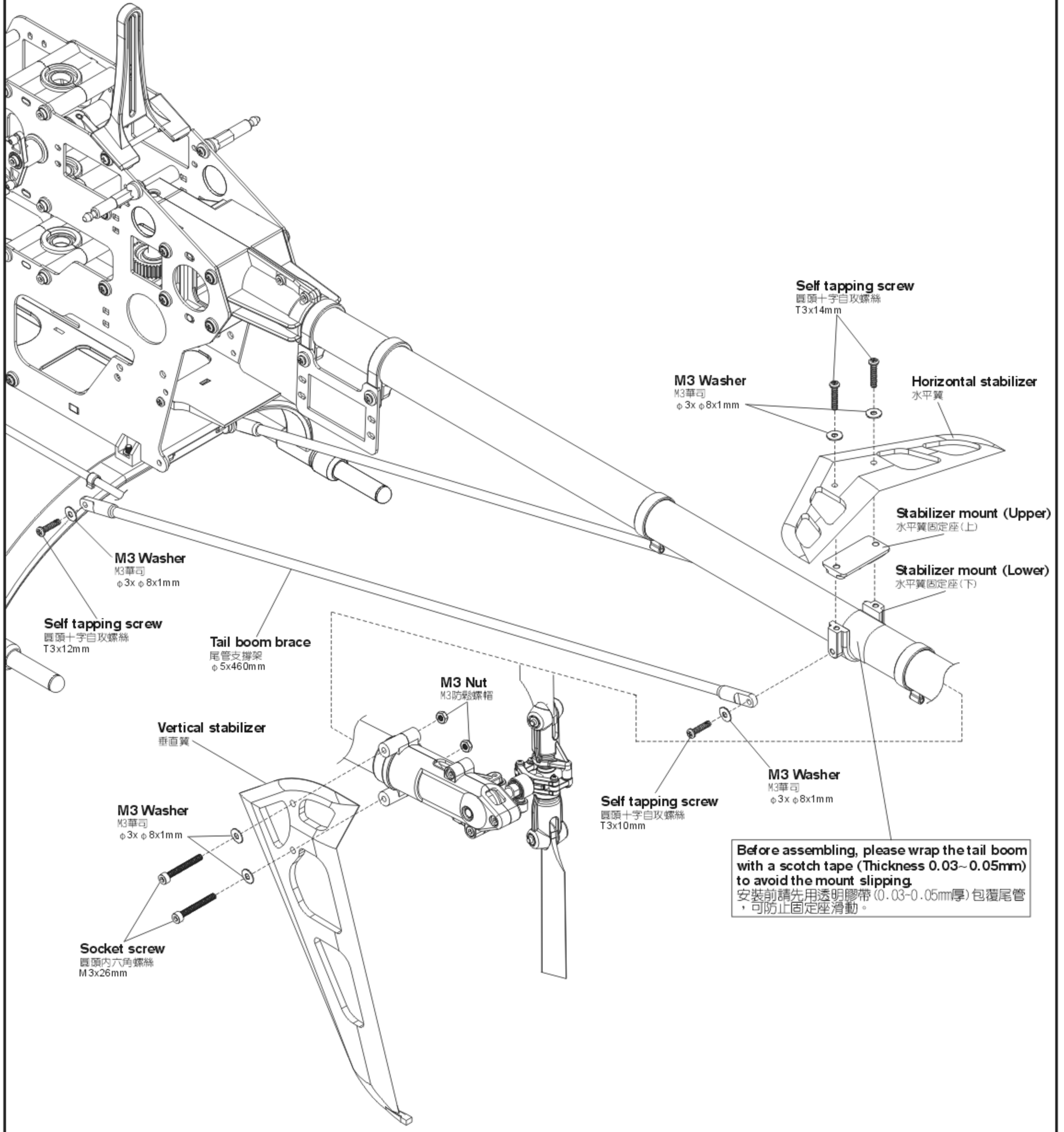

Before assembling, please wrap the tail boom with a scotch tape (Thickness 0.03~0.05mm) to avoid the mount slipping.  
安裝前請先用透明膠帶(0.03-0.05mm厚)包覆尾管，可防止固定座滑動。

# 50HZ007



## Self tapping screw

圓頭十字自攻螺絲(T3x14mm) x 16



## Socket screw

圓頭內六角螺絲(M3x10mm) x 2



## M3 Washer

M3華司(φ3xφ8x1mm) x 2

# 50HH004



## M4 Set screw

M4止洩螺絲(M4x4mm) x 2

Sticker  
平衡翼貼紙

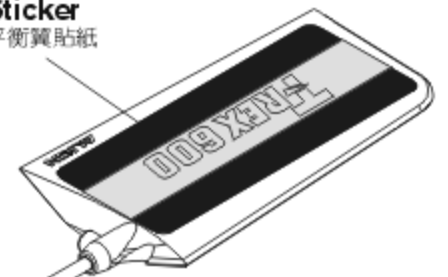

# 50HH001

Socket screw  
圓頭內六角螺絲  
M4x27mm

Separate purchasing  
另購

M4 Nut  
M4防鬆螺帽

Lock collar  
主軸固定環  
φ10xφ15x7mm

Socket screw  
圓頭內六角螺絲  
M3x10mm

M4 Set screw  
M4止洩螺絲  
M4x4mm

For motor fixing  
馬達固定螺絲

M3 Washer  
M3華司  
φ3xφ8x1mm

M3 Specialty washer  
M3特殊華司  
φ3xφ8x2mm

Self tapping screw  
圓頭十字自攻螺絲  
T3x8mm

# 50HB004

## Servo installation 伺服器組裝

# 50HZ007

GF servo plate  
玻璃纖維伺服器壓片 x 8

For two Aileron servos  
Aileron兩顆伺服器用

Aileron servo plate  
Aileron伺服器用塑膠墊片 x 4

Servo nut  
伺服器塑膠螺帽 x 8

Self tapping screw  
圓頭十字自攻螺絲  
T3x14mm

STD Servo  
標準伺服器

# 50HZ002

Motor  
馬達  
1220kV

Motor pinion gear 14T  
14T馬達齒輪

M4 Set screw  
M4止洩螺絲  
M4x4mm

When fixing the screw of pinion gear, please aim at the fixing point on motor shaft.  
銅齒固定螺絲鎖緊時，請對準馬達心軸固定槽。

Operating Voltage/使用電壓：  
DC 22.2V 6S 4000~5000mAh/16C Li-poly Battery

Apply a little amount of T43 thread lock when fixing a metal part.  
螺絲鎖附於金屬件請使用適量T43(螺絲膠)

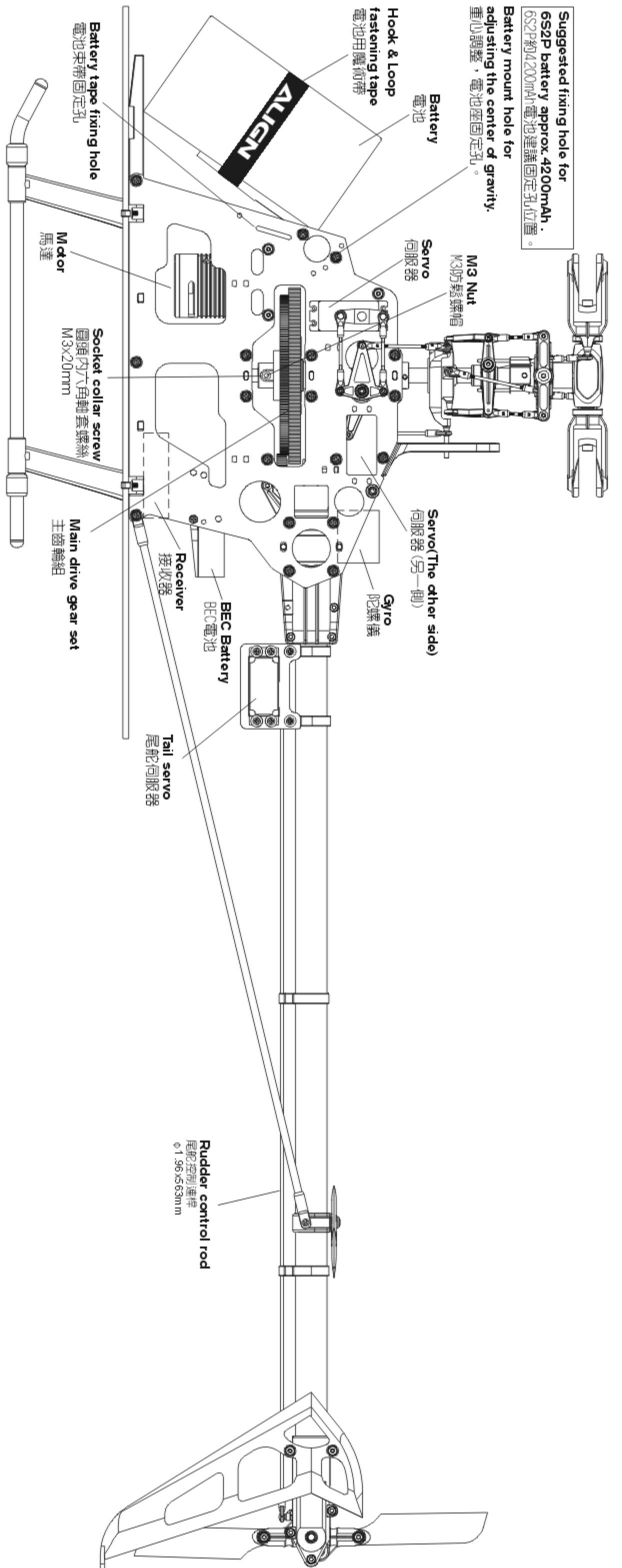

50HB001

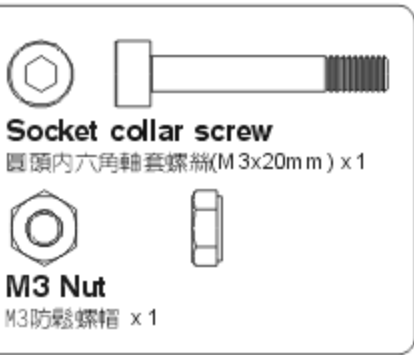

**HITEC、FUTABA 6CH receiver wiring**  
 HITEC、FUTABA 6CH接收器接線示意圖

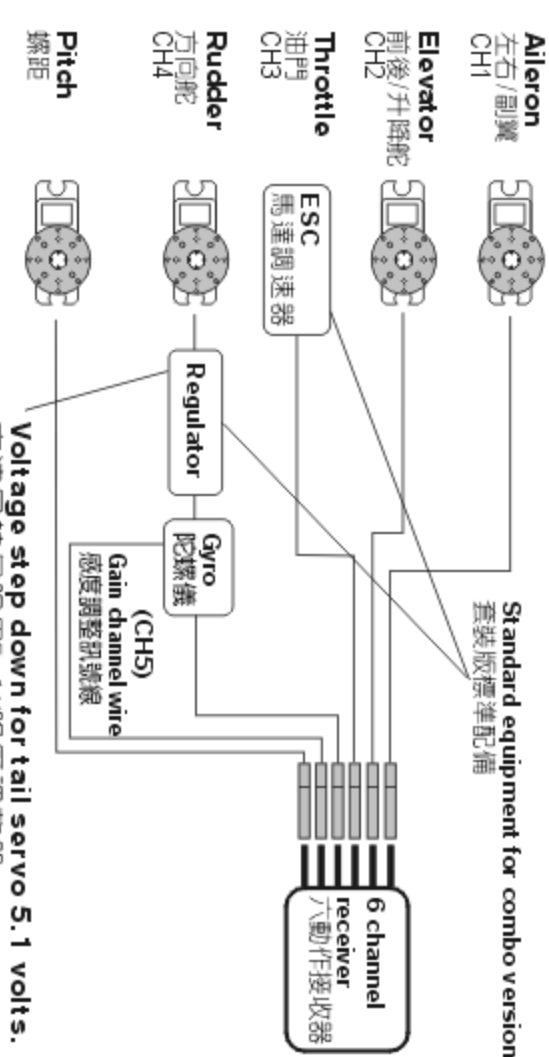

6-Channel Receiver is adequate for the requirements of the T-REX heli. You will need the following channels at a minimum: Throttle, Rudder, Elevator, Aileron, and especially Pitch(CH6) and Gyro(CH5) controls. 六動作的接收器已足夠應對T-REX遙控直升機的需求，除了油門、方向舵、升降舵、副翼等基本動作外，亦可以對應具備感度調整訊號線的陀螺儀(CH5)與螺距(CH6)。

**JR 7CH receiver wiring**  
 JR 7CH接收器接線示意圖

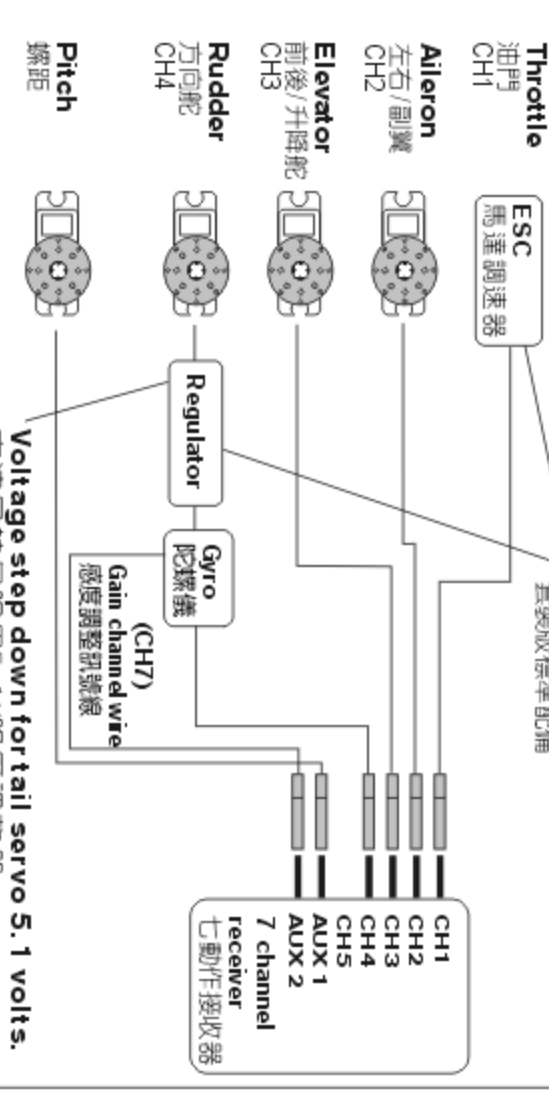

7-Channel Receiver is adequate for the requirements of the T-REX heli. You will need the following channels at a minimum: Throttle, Rudder, Elevator, Aileron, and especially Pitch(AUX 1) and Gyro(AUX 2) controls. 七動作的接收器已足夠應對T-REX遙控直升機的需求，除了油門、方向舵、升降舵、副翼等基本動作外，亦可以對應具備感度調整訊號線的陀螺儀(AUX 2)與螺距(AUX 1)。

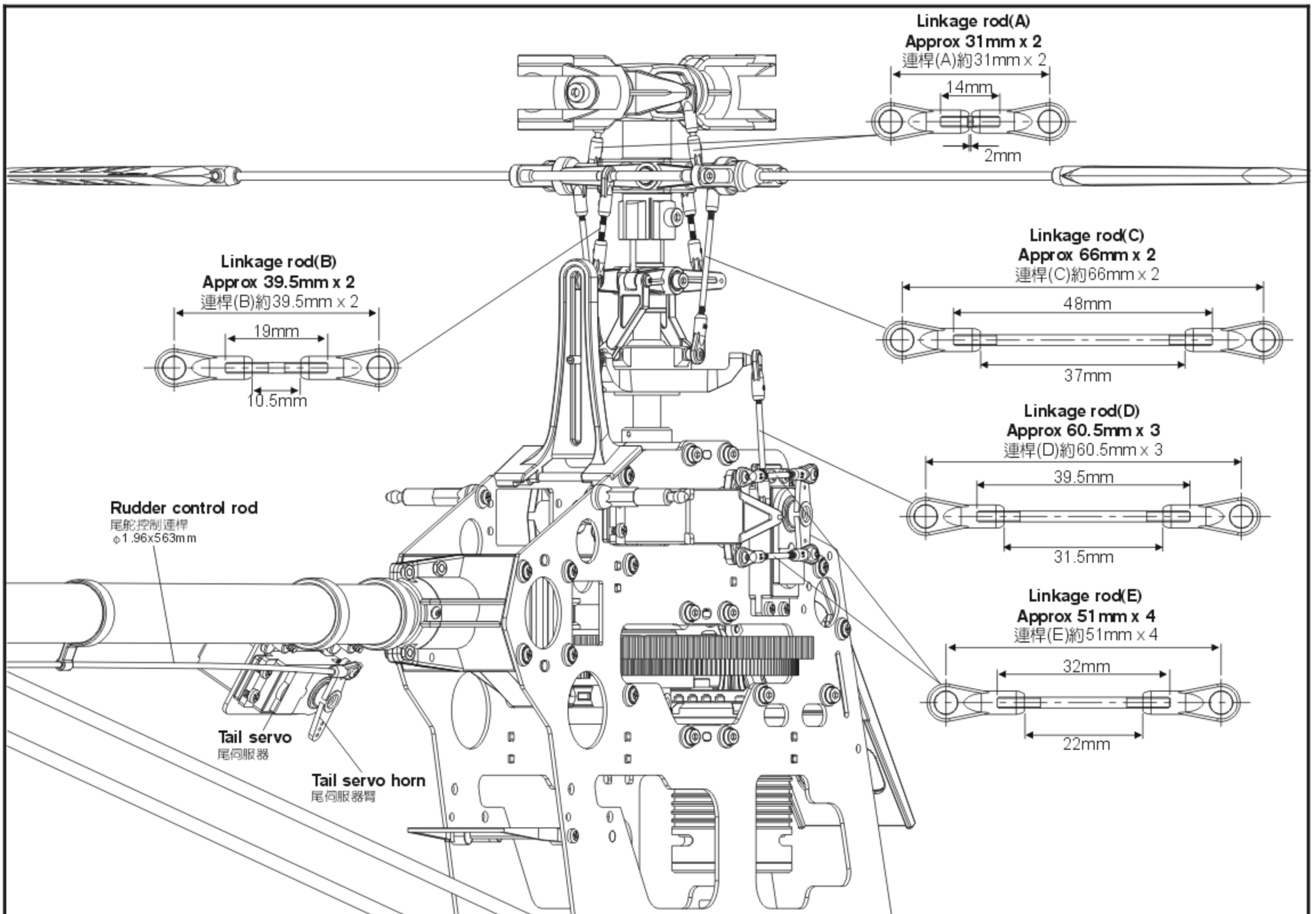
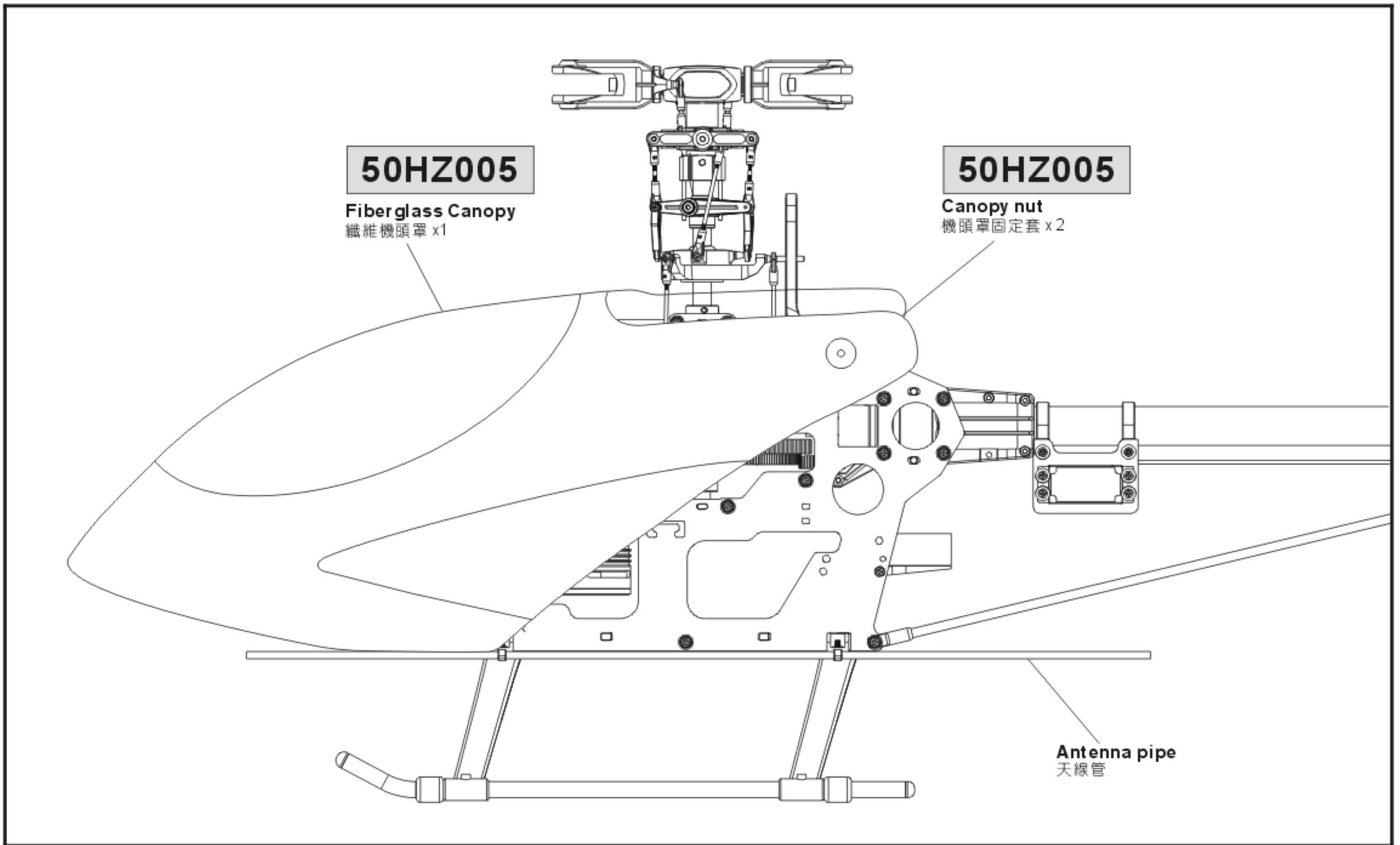

To set this option is to turn on the transmitter and connect to BEC power.

此項設定只要開啓發射器，接上BEC電源即可進行操作。

**JR Transmitter/Servo**  
JR遙控器對應伺服器關係

Aileron: CH2 副翼: CH2    Pitch: CH6 螺距: CH6

Pitch: CH6 螺距: CH6    Aileron: CH2 副翼: CH2

Elevator: CH3 升降舵: CH3

Linkage rod(F) Approx. 28mmx2  
連桿(F)約28mmx2

11mm

Please cut 1mm from each ball link.  
請將後控制臂連桿頭各切除1mm

Positions of CH2 · CH6 are exchangeable, After assembling as photo (Note: Set the transmitter under CCPM 120 degrees mode), pull throttle stick (pitch) upward. If one swashplate servo (or two servos) moves downward, adjust reverse switch (REV) on the transmitter to make it moves upward. If three servo move downward, adjust the travel value (+) of SWASH CH6 on the transmitter to make them move upward. When the actions of Aileron and Elevator are opposite, adjust travel values of SWASH CH2 and CH3.

CH2、CH6可互換配置，依圖連結後(注意：遙控器須設定於CCPM 120°十字盤模式)，將油門搖桿(Pitch)往上推，若十字盤伺服器有1個或2個往下移時，請調整遙控器的反轉開關(REV)使伺服器往上，若3個伺服器同時往下移時，請調整遙控器 SWASH CH6 行程量的正負值，使伺服器同時往上平移，副翼與前後動作相反時，同樣調整 SWASH CH2、CH3 行程量正負值。

**FUTABA/HITEC Transmitter/Servo**  
FUTABA/HITEC遙控器對應伺服器關係

Aileron: CH1 副翼: CH1    Pitch: CH6 螺距: CH6

Pitch: CH6 螺距: CH6    Aileron: CH1 副翼: CH1

Elevator: CH2 升降舵: CH2

Linkage rod(F) Approx. 28mmx2  
連桿(F)約28mmx2

11mm

Please cut 1mm from each ball link.  
請將後控制臂連桿頭各切除1mm

Positions of CH1 · CH6 are exchangeable, After assembling as photo (Note: Set the transmitter under CCPM 120 degrees mode), pull throttle stick (pitch) upward. If one swashplate servo (or two servos) moves downward, adjust reverse switch (REV) on the transmitter to make it moves upward. If three servo move downward, adjust the travel value (+) of SWASH CH6 on the transmitter to make them move upward. When the actions of Aileron and Elevator are opposite, adjust travel values of SWASH CH1 and CH2.

CH1、CH6可互換配置，依圖連結後(注意：遙控器須設定於CCPM 120°十字盤模式)，將油門搖桿(Pitch)往上推，若十字盤伺服器有1個或2個往下移時，請調整遙控器的反轉開關(REV)使伺服器往上，若3個伺服器同時往下移時，請調整遙控器 SWASH CH6 行程量的正負值，使伺服器同時往上平移，副翼與前後動作相反時，同樣調整 SWASH CH1、CH2 行程量正負值。

# 9.ADJUSTMENTS FOR GYRO AND TAIL NEUTRAL SETTING 陀螺儀與尾翼中立點設定調整

Recommend to choose Head Lock type for Gyro and turn off Revolution mixing(RVMX) mode on the transmitter, then set the gain switch on the transmitter and the gyro to Head lock mode. The gain setting is about 70%, and after transmitter setting, connect to BEC power to work on tail neutral setting. Note: When turn on BEC power, please do not touch tail rudder stick and the helicopter. Then wait for 3 seconds, make tail servo arm and tail servo at a right angle(90 degrees), tail pitch assembly must be correctly fixed about in the middle of the travel of tail rotor shaft for standard neutral setting.

陀螺儀選擇，建議選用鎖定式陀螺儀，其發射器內陀螺儀設定請關閉根軸混控模式，並將發射器上的感應開關與陀螺儀切至鎖定模式，感度設約 70% 左右，發射器設定完成後接上BEC接收電源，即可進行尾中立點設置。注意：當啓動BEC電源時請勿撥動尾舵搖桿或碰觸機體，待3秒陀螺儀鎖定後尾伺服器需與尾伺服器約成 90°，尾旋翼控制組須正確置於尾橫軸行程約中間位置，即為標準尾中立點設定。

**TAIL NEUTRAL SETTING 尾中立點設定**

After setting Head Lock mode, correct setting position of tail servo and tail pitch assembly is as photo. If the tail pitch assembly is not at the neutral position, please adjust the length of rudder control rod to trim.

陀螺儀鎖定後尾伺服器與尾 Pitch控制組正確擺置位置。若尾 Pitch控制組未置中時請調整尾控制連桿的長度來修正。

Middle tail pitch assembly. 尾Pitch控制組置中

Tail servo horn 尾伺服器擺臂

90°

Tail case set 尾齒輪組

**HEAD LOCK DIRECTION SETTING OF GYRO 陀螺儀鎖定方向設定**

To check the head lock direction of gyro is to move the tail counterclockwise and the tail servo horn will be trimmed clockwise. If it trims in the reverse direction, please switch the gyro to "REVERSE".

陀螺儀鎖定方向確認，當手搖尾部反時鐘擺動，尾伺服器應順時鐘修正，反向時請切換陀螺儀上"鎖定反向"開關修正。

Tail moving direction 搖動尾部方向

Trim direction for tail servo horn. 尾伺服器修正方向

## GENERAL FLIGHT 一般飛行模式

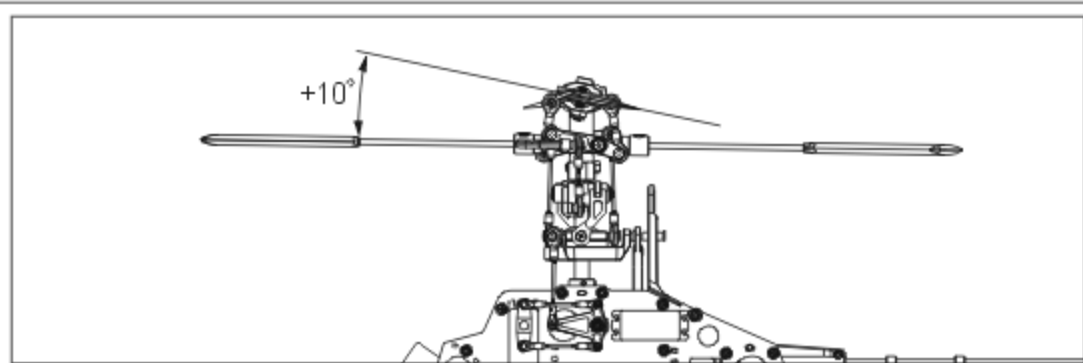

Stick position at high/Throttle 100%/Pitch +10°  
搖桿高速/油門100%/Pitch+10°

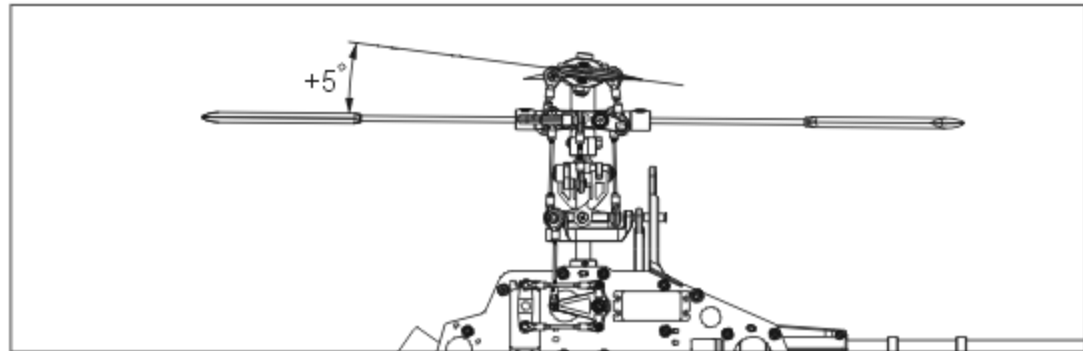

Stick position at Hovering/Throttle 65%~70%/Pitch +5°  
搖桿停懸/油門65%~70%/Pitch+5°

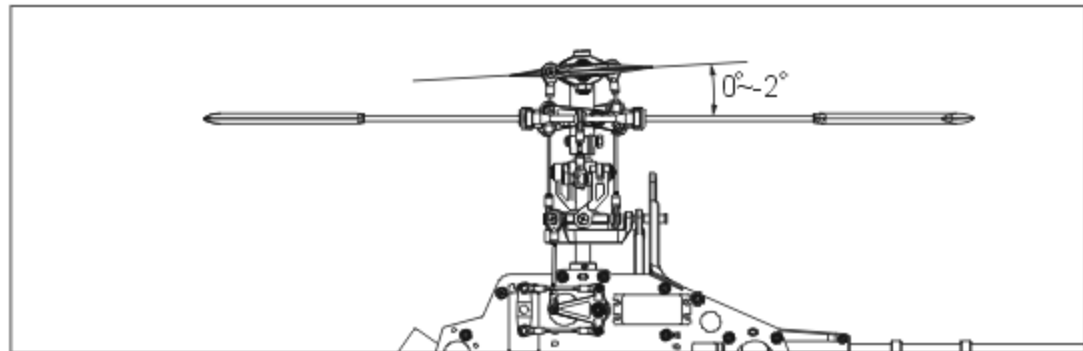

Stick position at low/Throttle 0%/Pitch 0°~-2°  
搖桿低速/油門0%/Pitch 0°~-2°

### GENERAL FLIGHT 一般飛行模式

Motor Pinion Gear:14T  
馬達主齒:14T

	Throttle 油門	Pitch 螺距	Current (approx.) 電流(約)	RPM (approx.) 轉速(約)
5	100% High speed 100% 高速	+10°	52A	2130
4	85%			
3	65% Hovering 65% 停懸	+5°	18A	1640
2	40%			
1	0% Low speed 0% 低速	0°	0	0

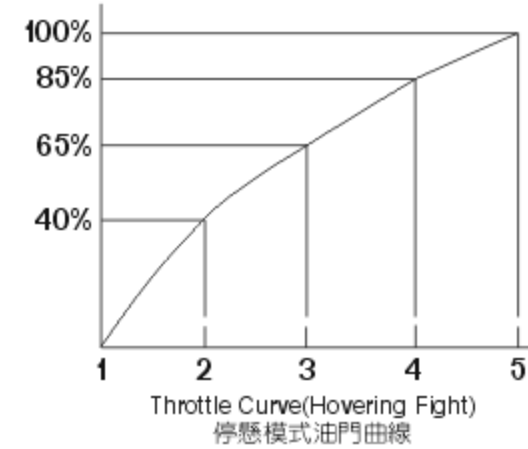

### Pitch and Rotation Speed Pitch與轉速關係

**TIP:** It is recommended to use a lower pitch setting when using higher RPM/Head speed. This will allow for better power.  
搭配要領: 如果使用較高轉速馬達動力建議搭配調低 Pitch, 將獲得較佳動力效能。

## 3D FLIGHT 3D特技飛行模式

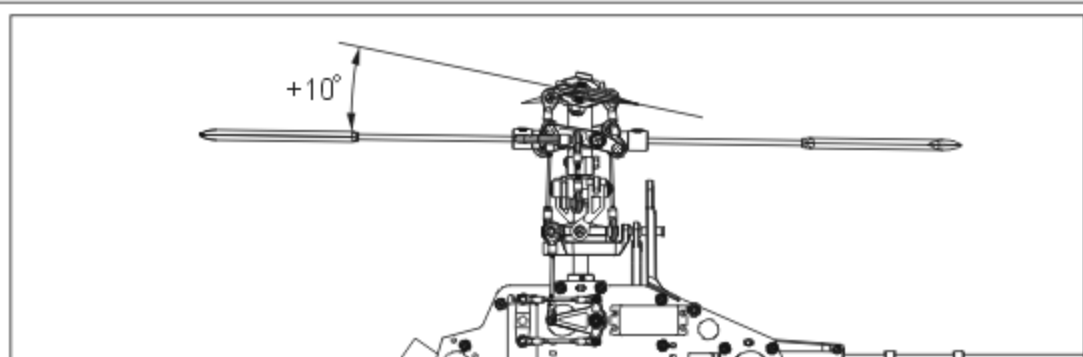

Stick position at high/Throttle 100%/Pitch +10°  
搖桿高速/油門100%/Pitch+10°

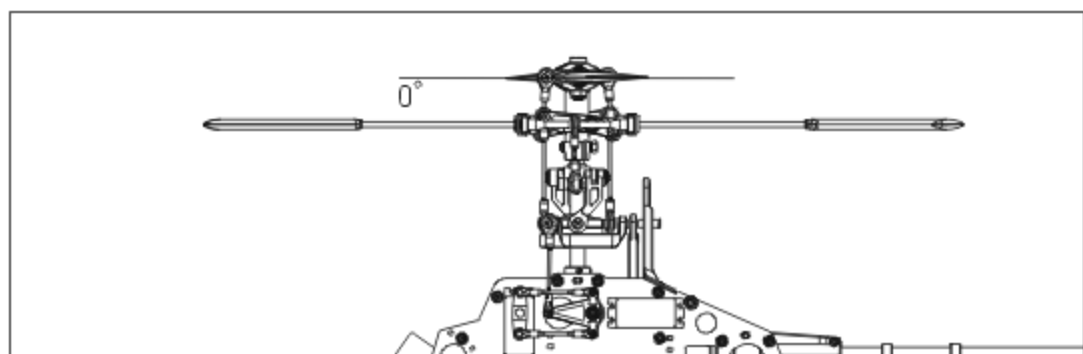

Stick position at middle/Throttle 85%/Pitch 0°  
搖桿中速/油門85%/Pitch 0°

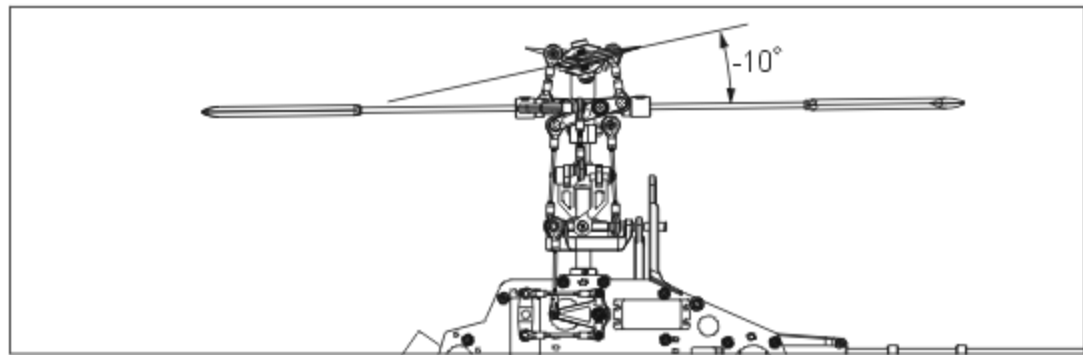

Stick position at low/Throttle 100%/Pitch -10°  
搖桿低速/油門100%/Pitch-10°

### IDLE 1: SPORT FLIGHT

Motor Pinion Gear:14T  
馬達主齒:14T

	Throttle 油門	Pitch 螺距	Current (approx.) 電流(約)	RPM (approx.) 轉速(約)
5	100%	+10°	52A	2130
4	75%			
3	70%	+5°	21A	1780
2	75%			
1	80%	-5°	21A	1880

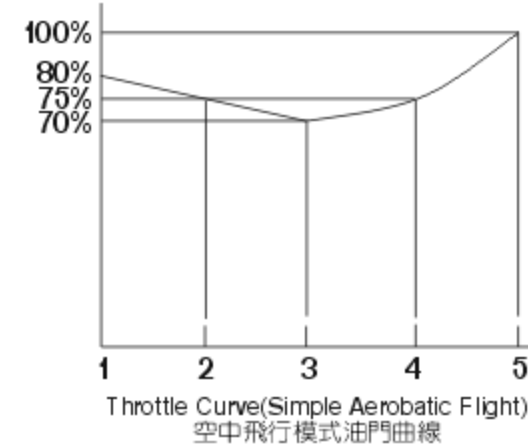

### IDLE 2: 3D FLIGHT

Motor Pinion Gear:14T  
馬達主齒:14T

	Throttle 油門	Pitch 螺距	Current (approx.) 電流(約)	RPM (approx.) 轉速(約)
5	100% High 100% 高	+10°	52A	2130
3	85% Middle 85% 中	0°	28A	2180
2	100% Middle 100% 中	0°	32.5A	2320
1	100% Low 100% 低	-10°	52A	2130

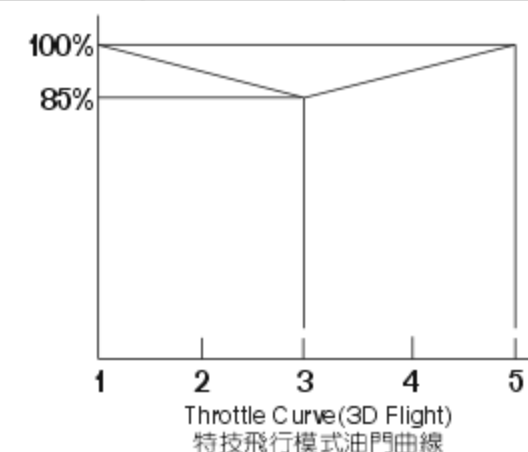

1. Pitch range: Approx 27 degrees.
2. If the pitch is set too high, it will result in shorter flight duration and poor motor performance.
3. Setting the throttle to provide a higher speed is preferable to increasing the pitch too high.



1. 螺距(Pitch)總行程約27°
2. 過大螺距設定, 會導致動力與飛行時間降低。
3. 動力提昇以較高轉速的設定方式, 優於螺距調大的設定。

**SPECIFICATION 規格**

Model 型號	Continuous Current 持續	Peak Current 瞬間	Dimension 尺寸	Weight 重量
RCE-BL100G	100A	135A	72x28x14mm	69g

1. Good temperature situation for working at the maximum current.
2. Supporting motor types: 2 ~ 10 pole in/outrunner brushless motors.
3. Supporting maximum RPM: 2 pole → 190,000 rpm ; 6 pole → 63,000 rpm.
4. Input voltage: 5.5V ~ 25.2V(2~6S Li-Po)

NOTE: 1. When setting to the Quick throttle response speed, the accelerative peak current will increase.  
2. Not including BEC output. User need to provide the power for receiver and servo.

1. 持續最大電流需在機體散熱良好情況下。
  2. 支援馬達型式: 二極至十數極之內轉子無碳刷馬達。
  3. 支援最高轉速: 二極→190,000rpm; 六極→63,000rpm。
  4. 輸入電壓: 5.5V~25.2V(鋰電2~6cell)
- 注意: 1. 設定為高油門反應速度時, 加速瞬間電流會有增大情形。  
2. 無BEC輸出, 需額外提供接收機及伺服器電源。

**WIRING ILLUSTRATION 接線示意圖**

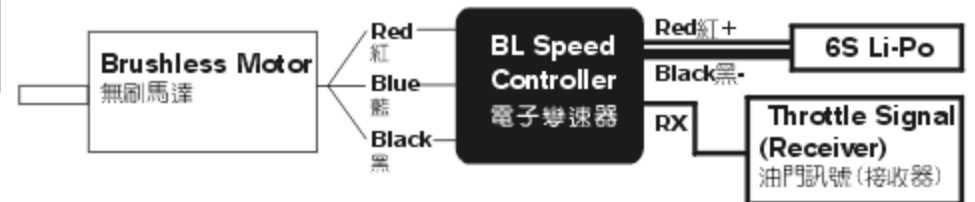

**FUNCTIONS 產品功能**

1. Brake Option - 3 settings that include Brake disabled/Soft brake/Hard brake.
  2. Electronic Timing Option - 3 settings that include Low timing/Mid timing/High timing. Generally, 2 pole motors are recommended to use low timing, while 6 or more poles should use Mid timing. High timing gives more power at the expense of efficiency. Always check the current draw after changing the timing in order to prevent overloading of battery.
  3. Battery Protection Option- 2 settings that include Li-ion, Li-poly High/Low cutoff voltage protection. The default setting is high cutoff voltage protection (suitable for hovering and general flight). CPU will automatically determine cell number of input Lithium battery (7.4~25.2V). This option will prevent over-discharge of the battery. The following reference is the guideline for setting the Battery Protection option.  
3-1 Li-ion/Li-poly High cutoff voltage protection-When the voltage of single cell drops to 3.2V, the first step of battery protection mode will be engaged by the ESC resulting in reduced power. The pilot should reduce the throttle and prepare landing. If the voltage of single cell drops to 3.0V, the second step of battery protection mode will be engaged resulting in power cutoff. (\*Note 1) For 11.1V/3cells Lithium battery, the full charged voltage will be approximately 12.6V. According to this input voltage, CPU will determine that this is a 3cell battery. First step protection: 3.2V x 3cell=9.6V Second step protection: 3.0V x 3cell= 9.0V When the voltage drops to 9.6V, the power will be reduced. When the voltage drops to 9.0V, the power will be cut off.  
3-2 Li-ion/Li-poly Middle cutoff voltage protection- This option is same as instruction 3-1, but when the voltage of single cell drops to 3.0V, the first step of battery protection will be engaged. When the voltage of single cell drops to 2.8V, the second step of battery protection will be engaged. (\*Note 1)  
Note 1: Second step of battery protection only works when Aircraft mode is setting to the option 4-1.  
NOTE : THIS OPTION IS ONLY SUITABLE FOR A FULLY CHARGED BATTERY PACK IN GOOD WORKING CONDITION.
  4. Aircraft Option: 3 settings that include Normal Airplane / Helicopter 1 / Helicopter 2. Normal Airplane Mode is used for general airplanes and gliders. When flying Helicopters, you can choose Helicopter 1 Mode, or Helicopter 2 Mode. Helicopter 1 Mode provides Soft Start feature. Helicopter 2 Mode provides Soft Start and Governor Mode.
  5. Throttle response speed: 3 settings that include standard/ Medium/ Quick throttle response speed. The default setting is "quick speed". Use this option to adjust the setting according to flight character. For example, setting at Medium or Quick speed for 3D and powerful flight to make the power response more quickly, but note the accelerative peak current and power expense will increase.
  6. Thermal Protection: When the ESC temperature reaches 80 °C for any reason, it will engage the battery protection circuit, reducing power to the ESC. We recommend mounting the ESC in a location with adequate air flow and ventilation.
  7. Safe Power On Alarm: When the operator turns on the ESC, it will automatically detect the transmitter signal. The ESC will emit a confirmation tone and enter normal operation mode if the throttle is set to the lowest position. If the throttle position is at full throttle, it will begin to enter Setup Mode. If the throttle is in any other position, the ESC will emit an alarm and not enter into user mode for safety precautions.
  8. Aircraft Locator: If the aircraft should land or crash in an unexpected location and become lost, the pilot can enable the Aircraft Locator Option. The Aircraft Locator Option is engaged by turning off the transmitter. When the ESC does not receive a signal from the transmitter for 30 seconds, it will start to send an alarm to the motor. The sound of the alarm will aid the pilot to locate the aircraft. This option will not work with a PCM receiver that has SAVE function enabled, or with low noise resistant PPM receivers.
1. 煞車設定: 三段選擇分為無煞車 / 軟性煞車 / 急煞車
  2. 進角設定: 三段選擇分為低進角 / 中進角 / 高進角  
設定時機分為二極以及六極以上無碳刷馬達, 二極無碳刷馬達一般適用低進角, 若希望馬達轉速提高, 可將進角設定為中進角。六極以上無碳刷馬達一般適用中進角, 若希望馬達轉速提高, 可將進角設定為高進角。然而進角之調整需要注意電流之變化, 避免電池過載, 影響電池及馬達壽命。
  3. 電池保護電壓設定: 二段選擇分為 Li-Ion、Li-Po 高截止電壓保護/低截止電壓保護  
出廠設定為高截止電壓保護(適合停旋及一般飛行使用); 此功能會自動判定所輸入鋰電池的cell數(7.4-25.2SV), 並提供使用者對該電池之放電保護, 以避免因放電電壓過低而造成電池損壞, 以下為設定值之解說:  
3-1 Li-Ion/Li-Po高截止電壓保護: 當鋰電單cell壓降達3.2V時, 電變會啟動第一階段保護, 使動力間歇性中斷, 此時使用者應將油門收小, 準備降落; 而當單cell電壓持續壓降達到3.0V時則會啟動第二階段保護, 完全限制動力輸出(註1:僅在4-1選項"一般飛機模式"下才會啟動第二階段保護)。  
例:以一個使用11.1V 3cell鋰電池之系統而言11.1V鋰電池充飽電壓約12.6V, 此輸入電壓CPU會自動判定為3cell鋰電。  
第一階段保護:3.2Vx3cell=9.6V 第二階段保護:3.0Vx3cell=9.0V 當電壓降至9.6V時, 動力會間歇性中斷, 當壓降達到9.0V時則完全限制動力輸出。  
3-2 Li-Ion/Li-Po中截止電壓保護:同3-1功能說明, 但單cell壓降達到3.0V時, 會啟動第一階段保護, 單cell壓降達到2.8V時啟動第二階段保護(註1)。  
注意:以上功能僅適用於充飽電, 且功能正常的鋰電池。
  4. 飛機模式設定: 三段式選擇分為: 一般飛機模式/直昇機模式1/直昇機模式2  
使用於一般飛機或滑翔機時, 請設定於一般飛機模式, 使用於直昇機時可選擇直昇機模式1: 具有緩啟動功能, 或直昇機模式2: 具有緩啟動及Governor Mode定速功能。
  5. 油門反應速度設定: 三段選擇分為標準/中速/快速  
出廠設定值為"快速"油門反應速度, 此功能提供使用者依所需的飛行特性來作適當的調整, 例如3D飛機與劇烈的3D直昇機飛行時可設定為中速或快速, 使動力反應更加快速、靈敏, 但須注意提高油門反應速度時, 加速瞬間電流與耗電量會有增大的情形。
  6. 溫度保護: 當電變因不良之空氣對流或是過載輸出導致溫度上升達 80°C時, 電變會啟動溫度保護, 而使動力間歇性中斷, 建議將電變裝置在機艙內空氣對流之位置, 並實際使用電流量表測輸出電流, 以達到電變之最佳效率。
  7. 開機防暴衝提醒功能: 當使用者開啓電變電源時, 系統會自動偵測發射機之設定, 如果發射機油門未置於最低點, 或未置於最高點準備進入設定模式, 馬達將不會轉動, 同時會有警示警響提醒。
  8. 尋機功能: 當飛機降若再長草區無法以目視定位時, 使用者可將發射機關閉, 當電變無法接收來自接收機信號時, 電變會於三十秒後使馬達發出警示警響, 以利定位。此功能不適用於設定了 SAVE 功能之 PCM 接收機, 或抗雜訊低之 PPM 接收機。

**SETUP MODE 設定模式**

1. Setup mode: Make sure to connect the ESC to the throttle channel of the receiver. Please refer to the user manual of your radio system. The second step is to connect the 3 power-out signal pins to the brushless motor. Before you turn on the transmitter, please adjust the throttle stick to the maximum full throttle position. Proceed to connect the battery to the ESC. You will hear confirmation sounds as soon as you enter the SETUP MODE. Please refer the attached flow chart for details.
  2. Throttle stick positions in Setup mode: Setup mode includes six settings: Brake, Electronic Timing, Battery Protection, Aircraft, Throttle Response Speed and BEC output voltage. Every setting has three options. Simply place the throttle stick in the highest, middle, and lowest positions for each setting. For example, first brake setting (Hard): move the stick to the highest position. Then timing setting (mid): move the throttle stick in the middle position.
1. 進入設定模式: 將電變與接收器之油門 Channel 連接, 不同之遙控系統請參閱您遙控系統之使用手冊, 馬達之三條線亦與電變連接, 將發射器之油門搖桿推到最高點, 使之於全油門狀態, 先開啓發射器電源, 再將電源連接至電變, 進入設定模式後, 馬達將有設定模式之提示警響。請參考第二頁程式化設定模式說明。
  2. 設定模式中之動作: 設定模式共含有五項設定, 分別為煞車、馬達進角、電池保護、飛機模式、油門反應速度, 詳細內容請參考產品功能之解說。除第三項外每一項設定中各含三段設定, 各項設定以油門搖桿之上、中、下位置來決定其設定值。  
例如: 煞車設定時, 油門搖桿撥至最高, 則設定為急煞車, 進入第二項進角設定時, 油門搖桿撥至中間, 則設定為中進角。

Mode 設定模式	Throttle position 油門搖桿	Low 低	Middle 中	High 高
Brake 煞車設定		● Brake disabled(1-1) 無煞車(1-1)	Soft brake(1-2) 軟性煞車(1-2)	Hard brake(1-3) 急煞車(1-3)
Electronic Timing 進角設定		Low-timing(2-1) 低進角(2-1)	● Mid-timing(2-2) 中進角(2-2)	High-timing(2-3) 高進角(2-3)
Battery Protection 電池保護電壓設定		● High cutoff voltage protection(3-1) 高截止電壓保護(3-1)	Middle cutoff voltage protection(3-2) 中截止電壓保護(3-2)	—
Aircraft 飛機模式設定		Normal Airplane/Glider(4-1) 一般飛機 / 滑翔機(4-1)	● Helicopter 1 (Soft Start)(4-2) 直升機模式1(緩啟動功能)(4-2)	Helicopter 2 (Soft Start+ Governor Mode)(4-3) 直升機模式2(緩啟動+Governor Mode定速功能)(4-3)
Throttle response speed 油門反應速度設定		Standard(5-1) 標準(5-1)	Medium speed(5-2) 中速(5-2)	● Quick speed(5-3) 快速(5-3)

Note: "●" default setting  
註: "●" 表示出廠設定值

Chart A  
表A

**ESC START-UP INSTRUCTION 開機使用模式**



**CURRENT SETTINGS INDICATOR BEEPS EXPLANATION 開機模式設定響音提示說明**

First Beep Group Brake Status 第一個響音 煞車設定狀態提示	Second Beep Group Electronic Timing 第二個響音 進角設定狀態提示	Third Beep Group Battery protection Cutoff 第三個響音 電池保護設定狀態提示	Fourth Beep Group Aircraft Status 第四個響音 飛機模式設定狀態提示	Fifth Beep Group Throttle Response 第五個響音 油門反應速度設定狀態提示
<ul style="list-style-type: none"> <li>Brake disabled = 無煞車</li> <li>Soft brake = 軟性煞車</li> <li>Hard brake = 急煞車</li> </ul>	<ul style="list-style-type: none"> <li>Low timing (apply to 2 pole inrunner motors) = 低進角(適合2線內轉子馬達)</li> <li>Mid timing (apply to 6 pole in/out runner motors) = 中進角(適合6線內外轉子馬達)</li> <li>High timing (apply to high power output) = 高進角(適用於高功率輸出)</li> </ul> <p>High-timing/big power/power expense 高進角模式有較大功率與耗電特性</p>	<ul style="list-style-type: none"> <li>High cutoff voltage protection = 高截止電壓保護</li> <li>Middle cutoff voltage protection = 中截止電壓保護</li> </ul>	<ul style="list-style-type: none"> <li>Normal airplane/Glider = 一般飛機/滑翔機</li> <li>Helicopter 1 (Soft start) = 直升機模式1(緩啟動功能)</li> <li>Helicopter 2 (Soft start + Governor Mode) = 直升機模式2(緩啟動功能+Governor Mode定速功能)</li> </ul>	<ul style="list-style-type: none"> <li>Standard = 標準</li> <li>Medium speed = 中速</li> <li>Quick speed = 快速</li> </ul>

**INSTRUCTIONS ON AIRCRAFT MODE SETTINGS 飛機模式設定使用說明**

**Normal Airplane/Glider Mode (Option 4-1):**

This option is applied to general airplanes and gliders.

**Helicopter 1 Mode (Option 4-2):**

This option provides a soft start feature and is applied to Helicopters for Normal, Idle Up 1, or Idle Up 2 modes. Please note that the sensitivity of the gyro should be set lower when flying in Idle Up 1 or Idle Up 2 modes if tail hunting (wag) occurs due to higher rotor speed.

**Helicopter 2 Mode (Option 4-3):**

This option supports soft start as well as Governor Mode features and is applied to Helicopters for Idle Up 1 and Idle Up 2 modes (not suitable for Normal Flight Mode). When Governor Mode is in use, the throttle should be set between 75% and 85%. Again if tail wag occurs, lower the sensitivity of the gyro to eliminate the hunting effect. The Governor Mode may not work properly in cases of insufficient rotor speed (due to improper gear ratio), poor battery discharge capability, and improper setting of gyro sensitivity and the blade pitch, etc. Please make sure all the proper adjustments have been done when using Governor Mode.

一般飛機模式(選項4-1):適用於一般飛機及滑翔機。

直昇機模式1(選項4-2):具有緩啟動功能，適用於Normal、Idle1、Idle2等飛行模式，當切換至Idle1或Idle2模式，如有較高轉速造成陀螺儀有輕微的追蹤現象，此時應將陀螺儀的感度設定分別降低。

直昇機模式2(選項4-3):具有緩啟動及Governor Mode定速功能，適用於Idle1、Idle2特技飛行模式(不適合Normal飛行模式下選用)，選擇定速功能時，油門應定速在75%-85%之間，如果飛行時發現有輕微的追蹤現象時，應降低陀螺儀的感度；由於轉速不足(齒比搭配不當)，電池效能不佳，陀螺儀感度設定不當，Pitch設定錯誤，皆會導致無法發揮定速的功能，甚至產生尾部偏擺的情形，所以選擇此模式時應針對相關條件進行確認。

**SETUP MODE 程式化設定模式**

Minimum 4 channel radio is required 四動以上標準發射器均可執行設定

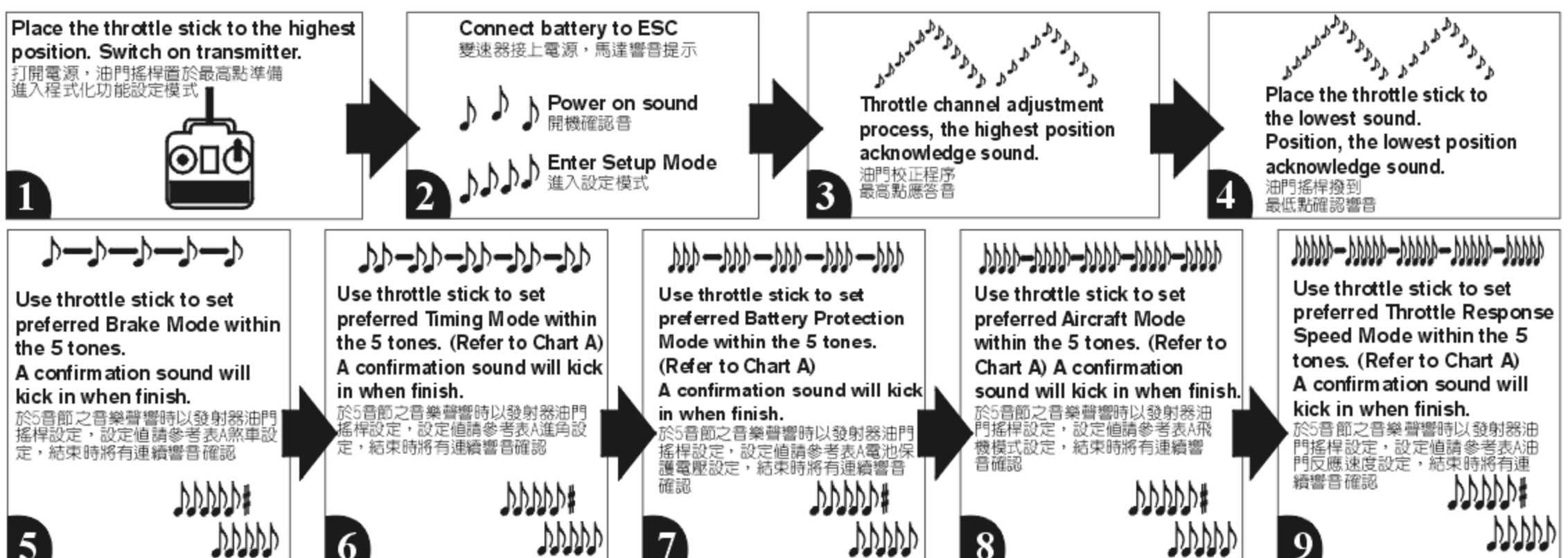

**12.6A EXTERNAL BEC INSTRUCTION MANUAL 6A外接式BEC使用說明**



- Input voltage: DC7.4V 2cell Lithium battery ● Output voltage: DC5.8V ● Max. Continuous Current: 6A
- Integrated power switch and voltage indicator meter ● Utilizes a linear design, resulting in no interference to the receiver.
- Including a 5A 5.1V two-way step-down Voltage Regulator ● Size: 60x34x15mm ● Weight: 31g(including wire set)



- 輸入電壓:DC 7.4V 2CELL鋰電 ●輸出電壓:DC 5.8V ●最大連續輸出電流:6安培 ●具電源切換開關與電壓指示燈功能
- 採線性設計，無干擾接收機的缺點 ●附5A 5.1V雙向降壓器 ●尺寸:60x34x15mm ●重量:31g(含線組)

**WIRING ILLUSTRATION:**

Connect a 5.1V two-way step-down voltage regulator between the gyro and the rudder servo.

接線示意圖：

5.1V 雙向降壓器連接於陀螺儀與尾舵伺服器之間。

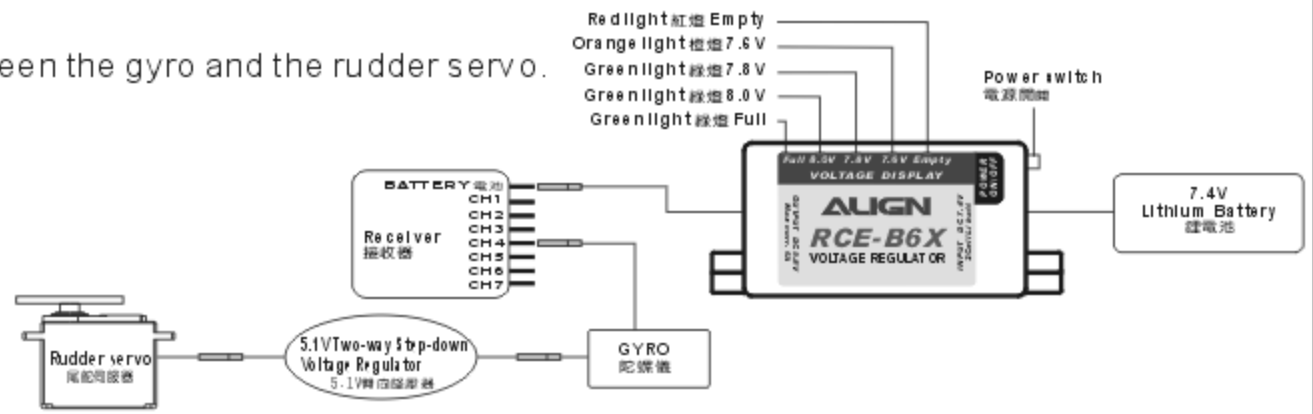

**Instruction:**

1. Auto-detecting voltage meter display lights. If the entire five-light array is illuminated, the battery is fully charged. When the voltage drops below 7.6V, the three green lights will be turned off. Use caution, the battery can only be safely used for a single flight. When only the red light is on, the battery voltage is drained, and must be fully recharged before use. Do not attempt to operate the model during this condition!
  2. Some servos such as Futaba servo models 9241, 9251, 9253, 9254, 9255, 9256 and other digital servos are not capable of handling 6V. Please connect a 5.1V two-way step-down voltage regulator to avoid the servo damaged. If you are using a servo that can accept 6V input, the regulator is not required.
  3. When using a speed controller with BEC output, you must remove the red wire of BEC output on the speed controller.
  4. If the receiver does not have enough channels or an available socket, you can use a Y-type servo harness to share any channel with an existing connection.
1. 本產品具電壓指示功能，當接入充飽的電池時五顆指示燈全亮，表示電池在Full電量充足狀態下；使用中當電壓降低至7.6V時(3顆綠燈熄滅)，尚可完成單趟飛行即須對電池充電或更換新電池；而如果僅亮紅燈時表示Empty電量不足，不應該再使用囉！
  2. 部份的伺服器如：Futaba 9241、9251、9253、9254、9255、9256等，此類型的伺服器不適合於較高的電壓下操作，所以使用此類型的伺服器時請另外加裝5.1V降壓器，避免伺服器損壞；規格標示准許6V輸入的伺服器則不須使用降壓器。
  3. 使用具BEC輸出之調速器時，必須將調速器 BEC 輸出的紅色線拆除！
  4. 若接收機已無多餘的電源插孔時，可利用一條伺服 Y 型連接線，接到接收機的任一通道，再將外接 BEC 與拆下的通道一同接在 Y 型線上。

**NOTE:** When fixing the wire, please do not over tighten to avoid the connector come off or the wire broken when the helicopter rotates(vibration); do not operate in rain or moisture environment to avoid the electric parts short circuit and damaged.

注意：固定線組時勿將各線組繃緊，以免直昇機運轉時因震動造成接頭鬆脫或斷線；避免在雨中或潮濕的環境下使用，以免造成零件短路而損壞。

**13.FLIGHT ADJUSTMENT AND SETTING 飛行動作調整與設定**



**PLEASE PRACTICE SIMULATION FLIGHT BEFORE REAL FLYING 飛行前請事先熟練模擬飛行**

Do a simulation flight until you familiarize your fingers with the movements of the rudders, and keep practicing until the fingers move naturally.

1. Place the helicopter in a clear open field ( Make sure the power OFF ) and the tail of helicopter point to yourself.
2. Practice to operate the throttle stick(as below illustration) and repeat practicing "Throttle high/low", "Aileron left/right", "Rudder left/right", and "Elevator up/down".
3. The simulation flight practice is very important, please keep practicing until the fingers move naturally when you hear operation orders being call out.
4. Another safe and effective practice method is to use the transmitter flying on the computer through simulator software sold on the market.

在還沒瞭解直昇機各動作的操控方式前，嚴禁通電飛行，請先進行模擬飛行的練習，並不斷的重複，直到手指可熟練的控制各個動作及方向。

1. 將直昇機放在空曠的地方(確認電源為關閉)，並將直昇機的機尾對準自己。
2. 練習操作遙控器的各搖桿(各動作的操作方式如下圖)，並反覆練習油門高/低、副翼左/右、升降舵前/後及方向舵左/右操作方式。
3. 模擬飛行的練習相當重要，請重複練習直到不需思索，手指能自然隨著喊出的指令移動控制。
4. 另外一種最有效、最安全的練習方式，就是透過市面販售的模擬軟體，以遙控器在電腦上模擬飛行，熟悉各種方向的操控。

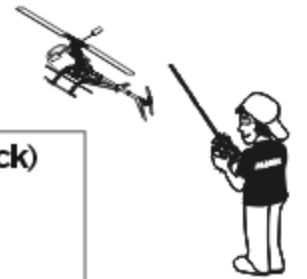

<b>ESC setting (RCE-BL100G):</b> 調速器設定建議:	<b>1-1 Brake Disable</b> 1-1 無煞車	<b>3-2 Battery Protection(Middle)</b> 3-2 電池電壓保護	<b>5-3 Throttle response (Quick)</b> 5-3 高油門反應速度
	<b>2-2 Mid timing</b> 2-2 中進角	<b>4-2 Helicopter 1</b> 4-2 直昇機模式1	

Mode 1	Mode 2	Illustration圖示

## FLIGHT ADJUSTMENT AND NOTICE FOR BEGINNERS 初學飛行調整與注意



- ⊙ Check if the screws are firmly tightened.
- ⊙ Check if the transmitter and receivers are fully charged.
- ⊙ 再次確認→螺絲是否鎖固?
- ⊙ 發射器和接收器電池是否足夠。



If there are other radio control aircraft at the field, make sure to check their frequencies and tell them what frequency you are using. Frequency interference can cause your model, or other models to crash and increase the risk of danger. 假使飛行場有其他遙控飛機，請確認他們的頻率，並告知他們你正在使用的頻率，相同的頻率會造成干擾導致失控和大大地增加風險。

★ When arriving at the flying field.

★ 當抵達飛行場

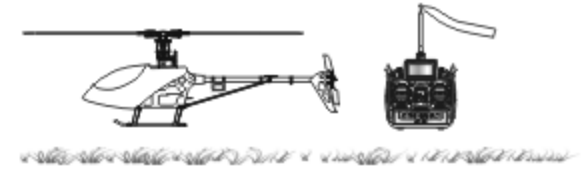

## STARTING AND STOPPING THE MOTOR 啟動和停止馬達



First check to make sure no one else is operating on the same frequency. Then place the throttle stick at lowest position and turn on the transmitter. 首先確認附近沒有其他相同頻率的使用，然後打開發射器將油門搖桿推到低點。

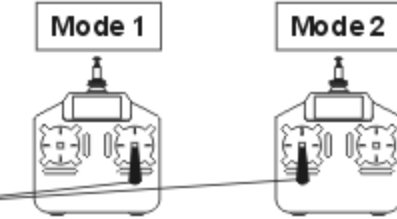

Check if the throttle stick is set at the lowest position. 確認油門搖桿是在最低的位置。

★ Check the movement. ⊙ Are the rudders moving according to the controls? ⊙ Follow the transmitter's instruction manual to do a range test.

★ 動作確認

- ⊙ 方向舵是否隨著控制方向移動?
- ⊙ 根據發射器說明書進行距離測試。

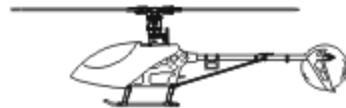

**ON! Step1**  
First turn on the transmitter.  
先開啓發射器

**ON! Step2**  
Next turn on the BEC of the receiver.  
再開啓接收器BEC電源

**ON! Step3**  
Connect to the battery  
接上主動力電源

**OFF! Step4**  
Reverse the above orders to turn off.  
關閉電源時請依上述操作動作反執行。

## Main rotor adjustments 主旋翼雙槳平衡調整



Tracking adjustment is very dangerous, so please keep away from the helicopter at a distance of at least 10m. 調整軌跡非常危險，請於距離飛機最少10公尺的距離。

1. Before adjusting, apply a red piece of tape on one blade, or paint a red stripe with a marker or paint to identify on blade.
  2. Raise the throttle stick slowly and stop just before the helicopter lifts-off ground. Look at the spinning blades from the side of the helicopter.
  3. Look at the path of the rotor carefully. If the two blades rotate in the same path, it does not need to adjustment. If one blade is higher or lower than the other blade, adjust the tracking immediately.
  4. Linkage rod (A): Regular pitch trim (For large variations). Linkage rod (C): Slight pitch trim (For slight variations).
1. 調整前先在其中一支主旋翼的翼端，貼上有顏色的貼紙或畫上顏色記號，方便雙槳調整辨識。  
2. 慢慢的推起油門搖桿到高點並且停止，在飛機離開地面前，從飛機側邊觀察主旋翼轉動。  
3. 仔細觀察旋翼軌跡(假如兩支旋翼移動都是相同軌跡，則不需要調整;可是如果一支旋翼較高或較低產生“雙槳”的情形時，則必須立刻調整軌跡)。  
4. 連桿(A)為一般螺距調整(雙槳翼大時使用)。連桿(C)為螺距微調調整(雙槳微幅差異時使用)。

- A. When rotating, the blade with higher path means the pitch too big. Please lengthen pitch linkage rod (A) for regular trim or shorten linkage rod (C) for slight pitch trim.**  
**B. When rotating, the blade with lower path means the pitch too small. Please shorten pitch linkage rod (A) for regular trim or lengthen linkage rod (C) for slight pitch trim.**

- A. 旋翼轉動時較高軌跡的主旋翼表示螺距(PITCH)過大，請調長連桿(A)修正，或需要更小的螺距微調時，請調短連桿(C)修正。  
B. 旋翼轉動時較低軌跡的主旋翼表示螺距(PITCH)過小，請調短連桿(A)修正，或需要更小的螺距微調時，請調長連桿(C)修正。



Incorrect tracking may cause vibrations. Please repeat adjusting the tracking to make sure the rotor is correctly aligned. After tracking adjustment, please check the pitch angle is approx. +4~5° when hovering.

不正確的旋翼軌跡會導致震動，請不斷重複調整軌跡，使旋翼軌跡精準正確。在調整軌跡後，確認一下Pitch角度在停旋時應為大約+4-5°。



## FLIGHT ADJUSTMENT AND NOTICE FOR BEGINNERS 初學飛行調整與注意



- ⊙ Make sure that no one or obstructions in the vicinity.
- ⊙ You must first practice hovering for flying safety. This is a basic flight action. (Hovering means keeping the helicopter in mid air in a fixed position)
- ⊙ 確認鄰近地區沒有人和障礙物。
- ⊙ 為了飛行安全，你必須先練習停旋，這是飛行動作的基礎(停旋:直昇機滯留空中並保持固定位置)。

- ⊙ Please stand approximately 10m diagonally behind the helicopter.
- ⊙ 練習時，請站在直昇機後方10公尺。

Beginner may install a training landing gear to avoid any crash caused by offset effect while landing. 必要時初學者可以在腳架下方安裝練習架，可避免降落時因重心偏移導致主旋翼或直昇機損毀。



## STEP 1 THROTTLE CONTROL PRACTICE 油門控制練習

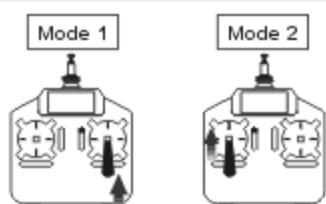

- ⊙ When the helicopter begins to lift-off the ground, slowly reduce the throttle to bring the helicopter back down. Keep practicing this action until you control the throttle smoothly.
- ⊙ 當直昇機開始離地時，慢慢降低油門將飛機降下。持續練習飛機從地面上的上升和下降直到你覺得油門控制很順。

## STEP 2 AILERON AND ELEVATOR CONTROL PRACTICE 副翼和升降控制練習

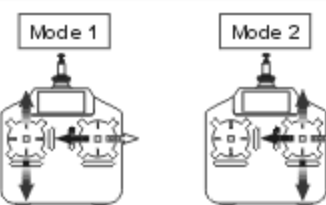

1. Raise the throttle stick slowly.
  2. Move the helicopter in any direction back, forward, left and right, slowly move the aileron and elevator sticks in the opposite direction to fly back to its original position.
1. 慢慢升起油門搖桿。  
2. 使直昇機依指示:移動向後/向前/向左/向右，慢慢的反向移動副翼和升降搖桿並將直昇機開回到原來位置。

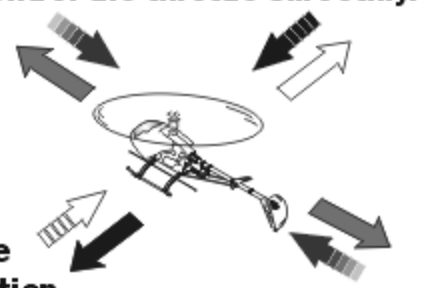

- ⊙ If the nose of the helicopter moves, please lower the throttle stick and land the helicopter. Then move your position diagonally behind the helicopter 10m and continue practicing.
- ⊙ If the helicopter flies too far away from you, please land the helicopter and move your position behind 10m and continue practicing.
- ⊙ 當直昇機機頭偏移時，請降低油門並且降落，然後移動自己的位置到直昇機的正後方10公尺再繼續練習。
- ⊙ 假如直昇機飛離你太遠，請先降落直昇機，並到直昇機後10公尺再繼續練習。

### STEP 3 RUDDER CONTROL PRACTICING 方向舵操作練習

1. Slowly raise the throttle stick.
  2. Move the nose of the helicopter to right or left, and then slowly move the rudder stick in the opposite direction to fly back to its original position.
1. 慢慢升起油門搖桿。  
2. 將直昇機機頭移動左或右，然後慢慢反向移動方向舵搖桿並將直昇機飛回原本位置。

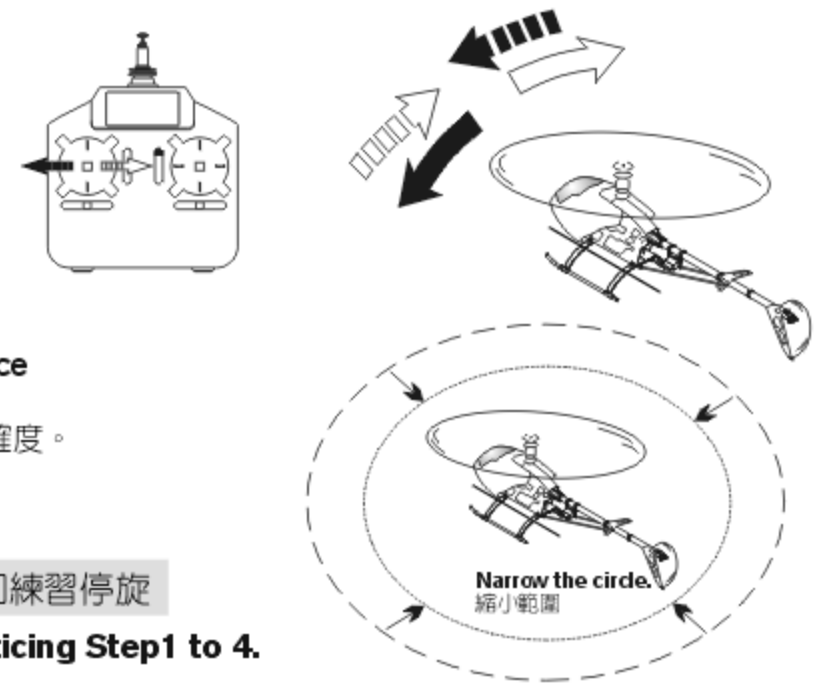

### STEP 4

After you are familiar with all actions from Step1 to 3, draw a circle on the ground and practice within the circle to increase your accuracy.  
當你覺得 step1-3 動作熟悉了，在地上畫圈並在這個圈圈的範圍內練習飛行，以增加你操控的準確度。

◎ You can draw a smaller circle when you get more familiar with the actions.  
◎ 當你更加習慣操作動作，你可以畫更小的圈。

### STEP 5 DIRECTION CHANGE AND HOVERING PRACTICE 改變直昇機方向和練習停旋

After you are familiar with Step1 to 4, stand at side of the helicopter and continue practicing Step1 to 4. Then repeat the Step1 to 4 by standing right in front of the helicopter.  
當你覺得step1-4動作熟悉了，站在面對直昇機側邊並繼續練習step1-4。之後，站在直昇機機頭右邊重複步驟練習。

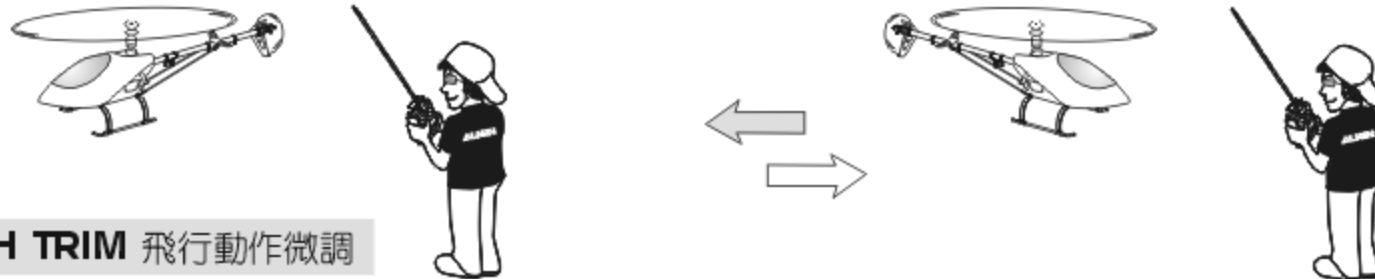

### ADJUSTMENT OF EACH TRIM 飛行動作微調

Slowly raise the throttle stick and just as the helicopter lift-off the ground, you can use the trim to correct the action if the helicopter leans in a different direction.  
慢慢升起油門搖桿，當直昇機剛剛離開地面時，若直昇機傾向不同方向，可使用微調修正動作。

#### 1. Adjustment of rudder trim 調整方向舵微調

Just before the helicopter lift-off, the nose lean left/right..  
When leans right, adjust the trim to left side.  
When leans left, adjust the trim to right side.  
在直昇機正要起飛時，機頭朝左/右方向偏移...  
向右偏移時，微調向左調整。  
向左偏移時，微調向右調整。

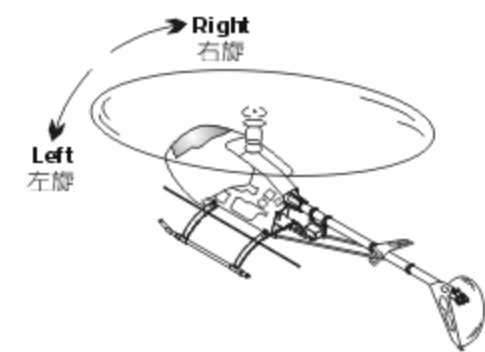
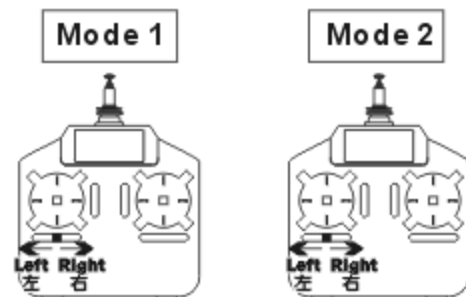

#### 2. Adjustment of elevator trim 調整升降舵微調

Just before the helicopter lift-off, the nose lean forward/backward..  
When leans forward, adjust the trim down.  
When leans backward, adjust the trim up.  
在直昇機正要起飛時，機頭朝前/後方向偏移...  
向前偏移時，微調向下調整。  
向後偏移時，微調向上調整。

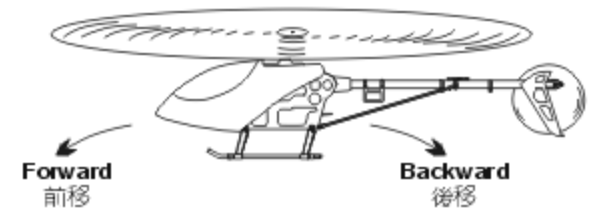
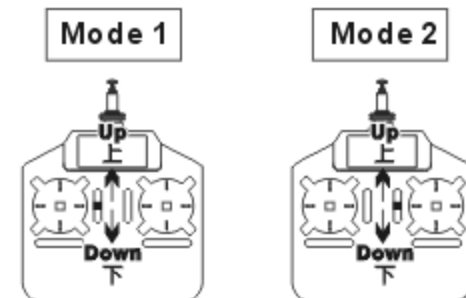

#### 3. Adjustment of Aileron trim 調整副翼微調

Just before the helicopter lift-off, the body lean left/right..  
When leans right, adjust the trim to left side.  
When leans left, adjust the trim to right side.  
在直昇機正要起飛時，機身朝左/右方向偏移...  
向右偏移時，微調向左調整。  
向左偏移時，微調向右調整。

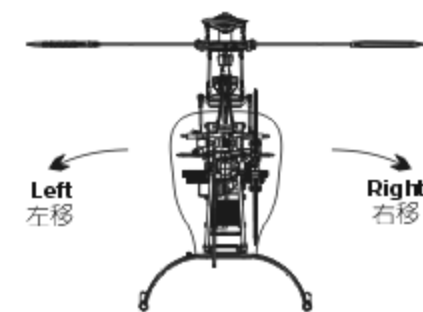
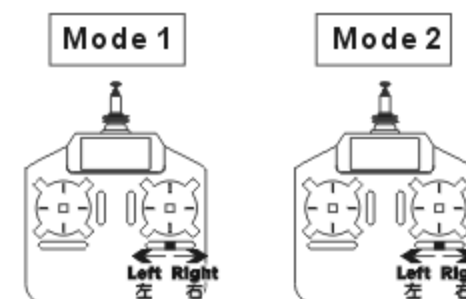

### TROUBLE SHOOTING DURING FLIGHT 如何排除飛行中的狀況

	Situation 狀況	Cause 原因	Way to deal 對策
Blade Tracking 雙槳平衡	Out of tracking 雙槳	Adjustment of pitch rod has not been done. PITCH連桿長度調整不平均	Adjust the length of linkage rod(A)→Regular trim Adjust the length of linkage rod(C)→Slight trim 調整連桿(A)長度→一般調整 調整連桿(C)長度→微調整
During Hovering 停旋	Low rotation of the rotor 主旋翼轉速偏低	★Pitch of main blade is high. ★主旋翼的PITCH偏高 ★Throttle curve is too low during hovering. ★停旋點油門曲線過低	★Lower the pitch about 4~5 during hovering(The rotation should be about 1,600rpm during hovering). ★調低pitch停旋Pitch約4-5(停旋時主旋翼需為約1600RPM) ★Heighten the throttle curve during hovering. ★調高停旋點油門曲線
	High rotation of the rotor 主旋翼轉速偏高	★Pitch of main blade is low. ★主旋翼的PITCH偏低 ★Throttle curve is too high during hovering. ★停旋點油門曲線過高	★Adjust the pitch rod <A> (The rotation should be about 1,600rpm during hovering). ★調整連桿<A>(停旋時主旋翼需為約1600RPM) ★Lower the throttle curve during hovering. ★調低停旋點油門曲線
Sensitivity of the gyro 陀螺儀敏感度	The tail leans to one side during hovering, or when trim the rudder and return to the neutral, the tail lags and cannot stay in a control position. 停旋時尾翼向某一邊偏移，或撥動方向舵並回復到中立點時，尾翼產生延遲，無法停頓在所控制位置上。	★Failure setting of tail neutral point. ★尾中立點設定不當 ★The sensitivity of the gyro is low. ★陀螺儀敏感度偏低	★Reset tail neutral point. ★重設尾中立點 ★Increase the sensitivity. ★增加敏感度
	The tail wags left and right during flight at hovering or full speed. 停懸或全油門時尾翼左右來回搖擺。	The sensitivity of the gyro is high. 陀螺儀敏感度偏高	Decrease the sensitivity. 降低敏感度

※If the problem is still there even after tried above, stop flying and contact with your seller.  
※在做完以上調整後，仍然無法改善情況時，應立即停止飛行並連絡您的經銷商。

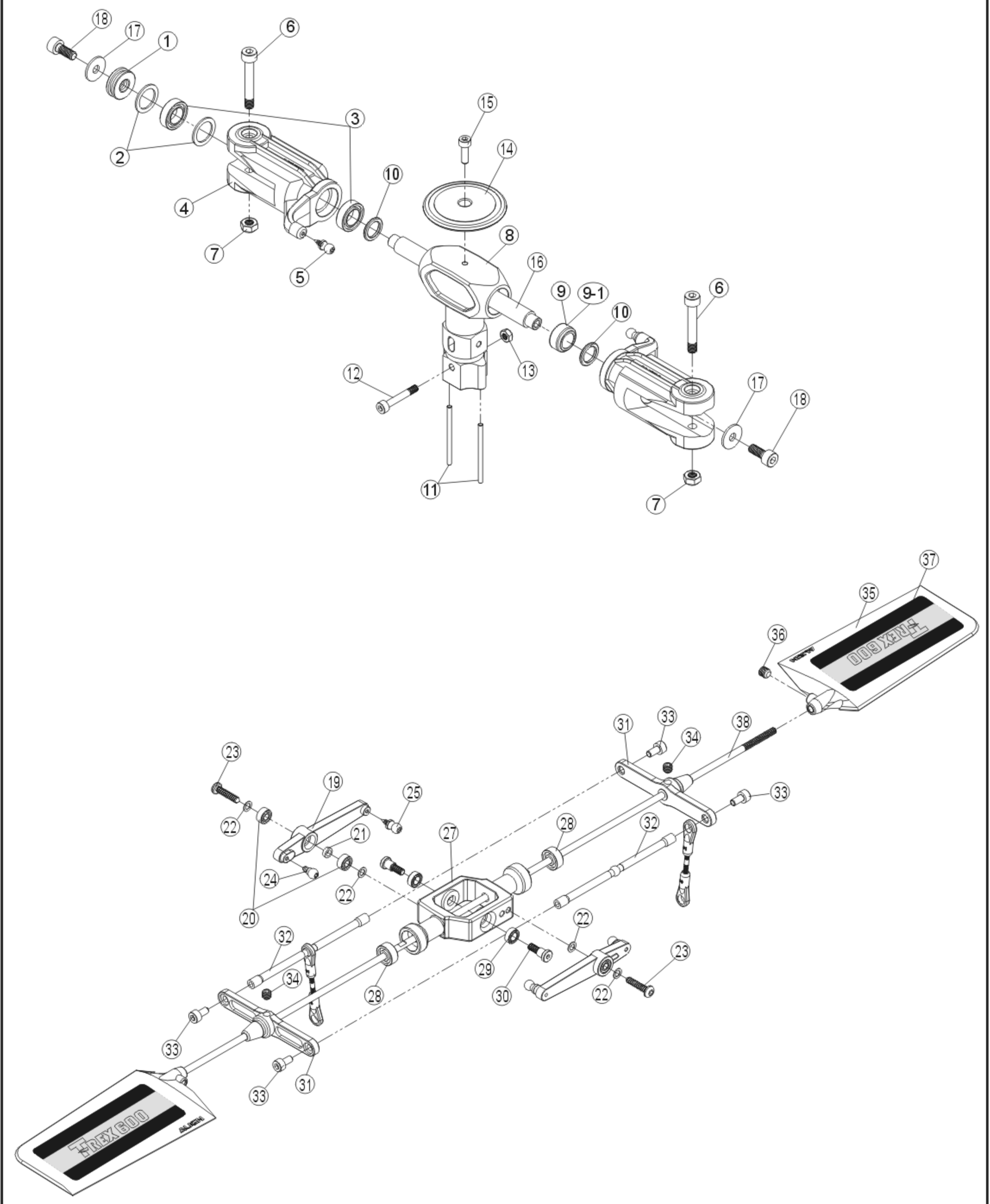

No.	Code No.	Name	Specification	Quantity	Remarks
1	50H009	Thrust bearing 止推軸承	φ 6x φ 14x5mm	2	
2	50H008-1	Spindle bearing spacer 橫軸軸承墊片	φ 10x φ 13.8x0.4mm	4	
3	50HMR148ZZ	Bearing MR148ZZ MR148ZZ軸承	φ 8x φ 14x4mm	4	
4	50H002-3	Main rotor holder 主旋翼夾座		2	
5	50H145-1	Linkage ball B(T2.6x5.5) 球頭B(T2.6x5.5)	φ 4.75x12.27mm	2	
6	T64027	Socket collar screw 圓頭內六角軸套螺絲	M4x27mm	2	
7	N14001	M4 Nut M4防鬆螺帽	M4	2	
8	50H001	Metal main rotor housing 金屬主旋翼固定座		1	
9	50NH008	Damper rubber-black 85° 橫軸墊圈-黑85°	φ 7.9x φ 13x6.5mm	2	
9-1	50NH013	Damper rubber-gray 70° 橫軸墊圈-灰70°	φ 7.9x φ 13x6.5mm	2	
10	50H006	Spacer 橫軸套圈	φ 8x φ 11.5x1.3mm	2	
11	50H136	Pin 定位插銷	φ 2x32mm	2	
12	T63022	Socket collar screw 圓頭內六角軸套螺絲	M3x22mm	1	
13	N10030	M3 Nut M3防鬆螺帽	M3	1	
14	50H164-1	Metal head stopper 金屬旋翼頭制動器		1	
15	T63010	Socket screw 圓頭內六角螺絲	M3x10mm	1	
16	50H003	Feathering shaft 橫軸	φ 6x φ 8x93.2mm	1	
17	50H010	Washer 橫軸華司	φ 4x φ 12x1mm	2	
18	T64010	Socket screw 圓頭內六角螺絲	M4x10mm	2	
19	50H025-4	SF Mixing arm SF控制搖臂		2	
20	50H683ZZ	Bearing 683ZZ 683ZZ軸承	φ 3x φ 7x3mm	4	
21	50H024	Collar 擺臂軸承襯套	φ 3x φ 4.8x1.5mm	2	
22	50H022-2	Washer 華司	φ 3x φ 4.8x0.3mm	4	
23	S23014-2	Self tapping screw 圓頭十字自攻螺絲	T3x14mm	2	
24	50H144-1	Linkage ball A(T2.6x3.5) 球頭A(T2.6x3.5)	φ 4.75x8.18mm	2	
25	50H145-1	Linkage ball B(T2.6x5.5) 球頭B(T2.6x5.5)	φ 4.75x12.27mm	2	
27	50H016-1	Flybar seesaw holder 平衡桿固定座		1	
28	50H623ZZ	Bearing 623ZZ 623ZZ軸承	φ 3x φ 10x4mm	2	
29	50HMR74ZZ	Bearing MR74ZZ MR74ZZ軸承	φ 4x φ 7x2.5mm	2	
30	50H119-2	M3 collar screw M3雙層軸套螺絲	M3x9.6mm	2	
31	50NH002	Metal flybar control arm 金屬平衡翼控制臂		2	
32	50H018-1	Flybar control rod 平衡翼球型控制球桿	φ 3.4x74.2mm	2	
33	T63005	Socket screw 圓頭內六角螺絲	M3x5mm	4	
34	T74004	M4 Set screw M4止洩螺絲	M4x4mm	2	
35	50NH001	Flybar paddle 平衡翼17g		2	
36	T73006	M3 Set screw M3止洩螺絲	M3x6mm	2	
37	D03958-1	Sticker 平衡翼貼紙		3組	
38	50H033	Flybar rod 平衡翼桿	φ 3x440mm	1	

**Specifications, contents of parts and availability are subject to change, Align RC is not responsible for inadvertent errors in this publications.**  
 本說明書內的材質、規格或零件包裝之內容物僅供參考。本公司將不對此印刷物之異動負責，也無法主動通知消費者，任何更新或異動，請以亞拓網頁為主。

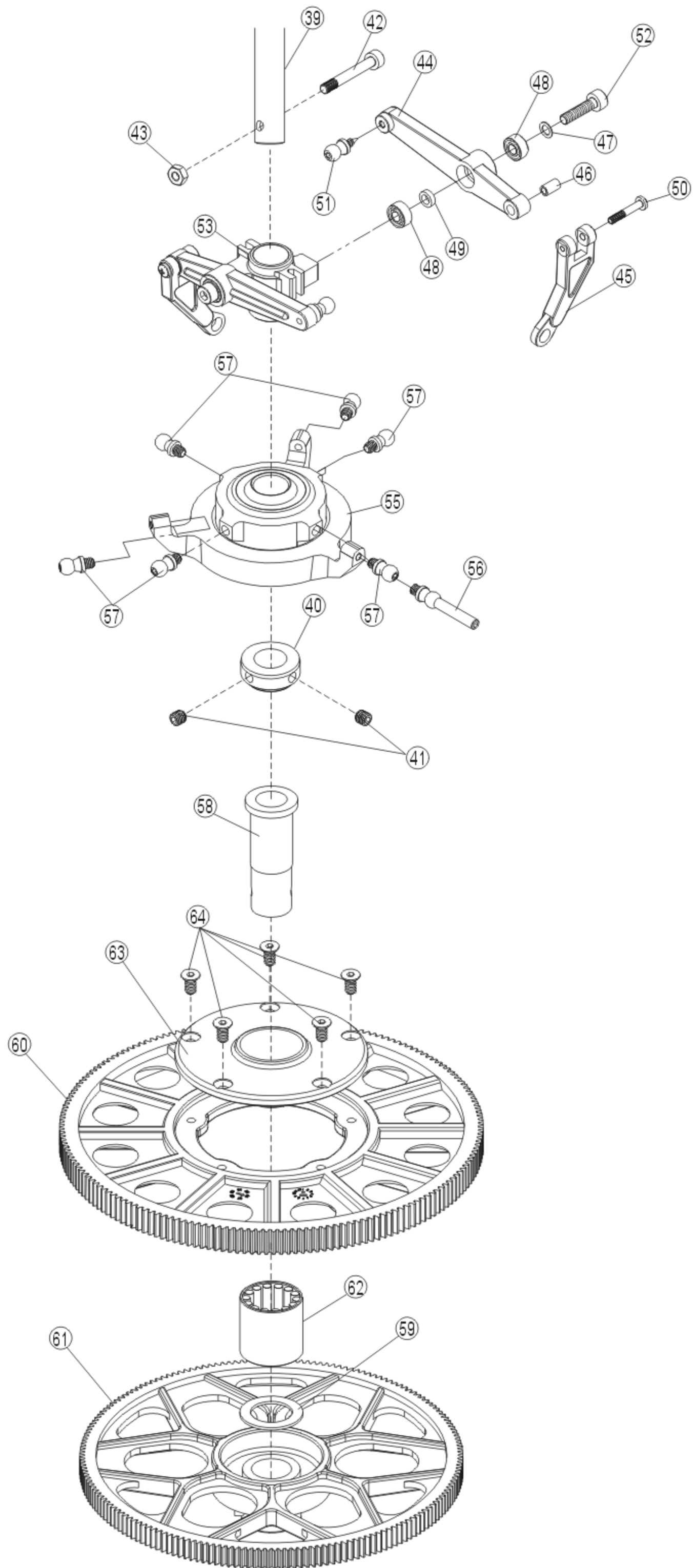

No.	Code No.	Name	Specification	Quantity	Remarks
39	50H047	Main shaft 主軸	φ 10x201mm	1	
40	50H045-1	Lock collar 主軸固定環	φ 10x φ 15x7mm	1	
41	T74004	M4 Set screw M4止洩螺絲	M4x4mm	2	
42	T63020	Socket collar screw 圓頭內六角軸套螺絲	M3x20mm	1	
43	N10030	M3 Nut M3防鬆螺帽	M3	1	
44	50H031-3	Washout control arm 穩定控制搖臂		2	
45	50H035	Radius arm Radius連桿		2	
46	50H126	Collar 穩定控制搖臂銅套	φ 2x φ 3x5.1mm	2	
47	50H022-2	Washer 華司	φ 3x φ 4.8x0.3mm	4	
48	50H683ZZ	Bearing 683ZZ 683ZZ軸承	φ 3x φ 7x3mm	4	
49	50H024	Collar 擺臂軸承襯套	φ 3x φ 4.8x1.5mm	2	
50	T12012-2	Collar screw 軸套螺絲	M2x12mm	2	
51	50H145-1	Linkage ball B(T2.6x5.5) 球頭B(T2.6x5.5)	φ 4.75x12.27mm	2	
52	T63012	Socket screw 圓頭內六角螺絲	M3x12mm	2	
53	50NH004	Metal washout base 金屬向位器		1	
55		CCPM Metal swashplate 金屬CCPM十字盤組		1	
56	50H041-1	Long linkage ball(M3x3) 導板長球頭(M3x3)	φ 4.75x24.59mm	1	
57	50H044	Linkage ball B(M3x3) 球頭B(M3x3)	φ 4.75x9.77mm	6	
58	50B048-2	One-way bearing shaft 單向軸承套	φ 9x φ 12x34.55mm	1	
59	50B050	Washer 單向軸承華司	φ 11.5x φ 18x0.5mm	1	
60	50B158-1	Main drive gear(170T) 主齒盤(170T)		2	
61	50B054-1	Autorotation tail drive gear 尾驅動主齒		2	
62	50B049-1	One-way bearing HF1216 單向軸承HF1216	φ 12x φ 18x16mm	1	
63	50B051-3	Main gear case 主齒中心座	φ 55x14.5mm	1	
64	S83007	Hex socket self tapping screw 皿頭內六角自攻螺絲	T3x7mm	5	

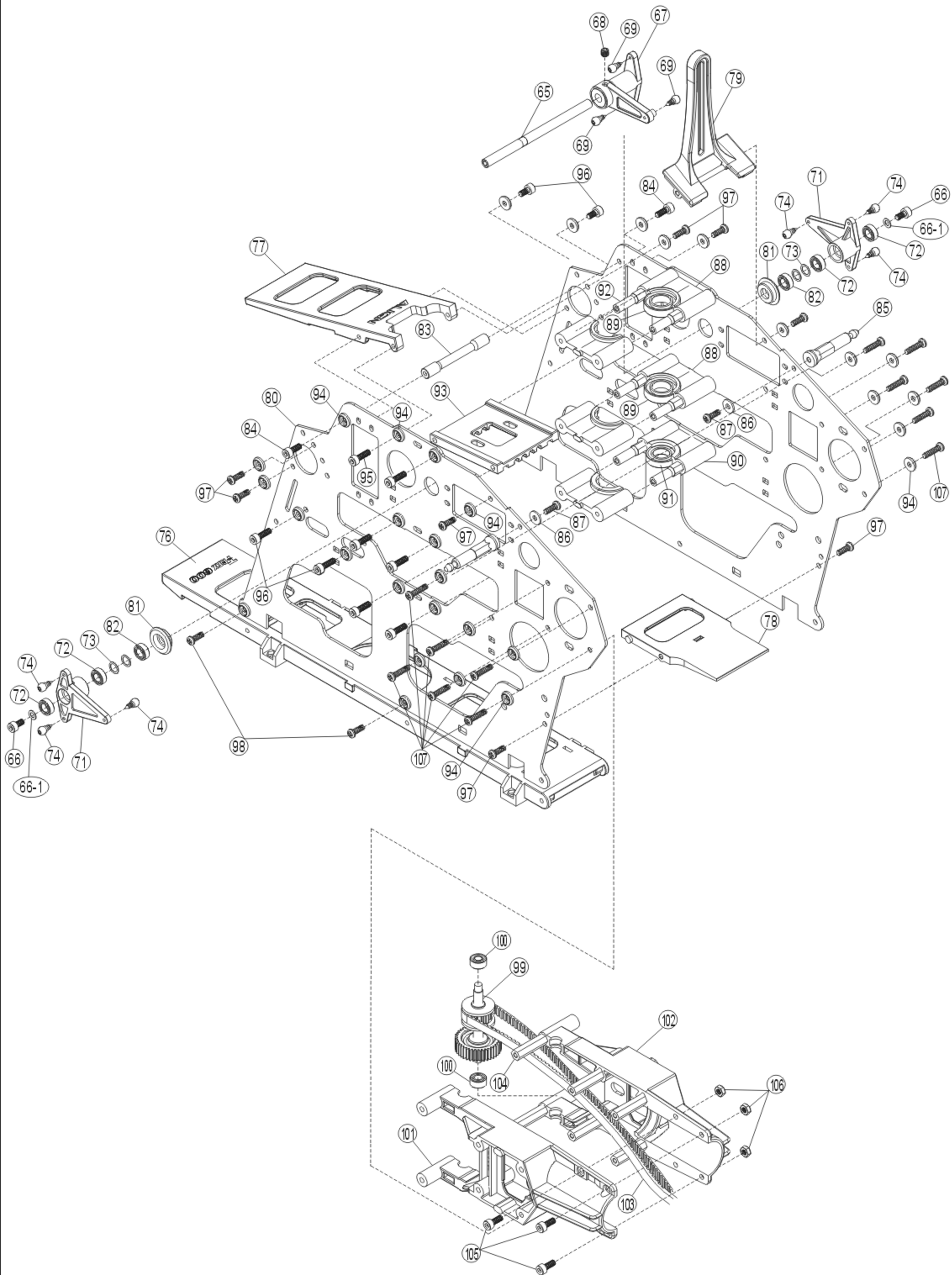



No.	Code No.	Name	Specification	Quantity	Remarks
65	50B070	Control shaft 連動桿	φ 5x81mm	1	
66	T63006	Socket screw 圓頭內六角螺絲	M3x6mm	2	
66-1	50H022	Washer 華司	φ 3x φ 5.5x0.3mm	2	
67	50B068-2	Elevator lever 後控制臂		1	
68	T74004	M4 Set screw M4止洩螺絲	M4x4mm	1	
69	50H144-1	Linkage ball A(T2.6x3.5) 球頭A(T2.6x3.5)	φ 4.75x8.68mm	3	
71	50B056-2	Aileron lever 左右控制搖臂		2	
72	50BMR95ZZ	Bearing MR95ZZ MR95ZZ軸承	φ 5x φ 9x3mm	4	
73	50B059	Washer 華司	φ 5x φ 7x0.2mm	2	
74	50H144-1	Linkage ball A(T2.6x3.5) 球頭A(T2.6x3.5)	φ 4.75x8.68mm	6	
76	50B073-1	Bottom bracket 主體底板		1	
77	50B064	Battery mount 電池固定座		1	
78	50B074-1	Gyro mount 陀螺儀固定座		1	
79	50B065	Anti rotation bracket 十字盤導板		1	
80	50B213	Fiberglass main frame 玻纖主體側板	1.6mm	2	
81	50B060	Bearing mount 控制臂軸承座	φ 9x φ 15x4.5mm	2	
82	50BMR95ZZ	Bearing MR95ZZ MR95ZZ軸承	φ 5x φ 9x3mm	2	
83	50B138	Frame mounting bolt 機身鋁柱		1	
84	T63008	Socket screw 圓頭內六角螺絲	M3x8mm	2	
85	50B121	Canopy mounting bolt 機頭罩固定柱		2	
86	W10030	M3 Washer M3華司	φ 3x φ 8x1mm	2	
87	S23010-2	Self tapping screw 圓頭十字自攻螺絲	T3x10mm	2	
88	50B061	Upper bearing block(A) 主軸上軸承固定座(A)		4	
89	50B6800ZZ-2	Bearing 6800ZZ 6800ZZ軸承	φ 10x φ 19x5mm	2	
90	50B066	Lower bearing block(B) 主軸下軸承固定座(B)		2	
91	50B689ZZ-1	Bearing 689ZZ 689ZZ軸承	φ 9x φ 17x5mm	1	
92	50H148	Aluminum hexagonal bolt 六角鋁柱		6	
93	50B063	Motor mount 馬達固定座		1	
94	50B072	M3 Specialty washer M3特殊華司	φ 2x φ 8x2mm	40	
95	T63010	Socket screw 圓頭內六角螺絲	M3x10mm	12	
96	T63006	Socket screw 圓頭內六角螺絲	M3x6mm	4	
97	S23008-2	Self tapping screw 圓頭十字自攻螺絲	T3x8mm	8	
98	S23010-2	Self tapping screw 圓頭十字自攻螺絲	T3x10mm	4	
99		Tail drive gear assembly 尾傳動輪組		1	
100	50B684ZZ	Bearing 684ZZ 684ZZ軸承	φ 4x φ 9x4mm	2	
101	50B076-2	Tail boom mount(Left) 尾管固定座(左)		1	
102	50B075-2	Tail boom mount(Right) 尾管固定座(右)		1	
103	50T131-1	Tail drive belt 尾傳動皮帶	592XL	1	
104	50B077	Plastic hexagonal bolt 六角塑膠柱		6	
105	T63008	Socket screw 圓頭內六角螺絲	M3x8mm	3	
106	N10030	M3 Nut M3防鬆螺帽	M3	3	
107	S23012-2	Self tapping screw 圓頭十字自攻螺絲	T3x12mm	12	

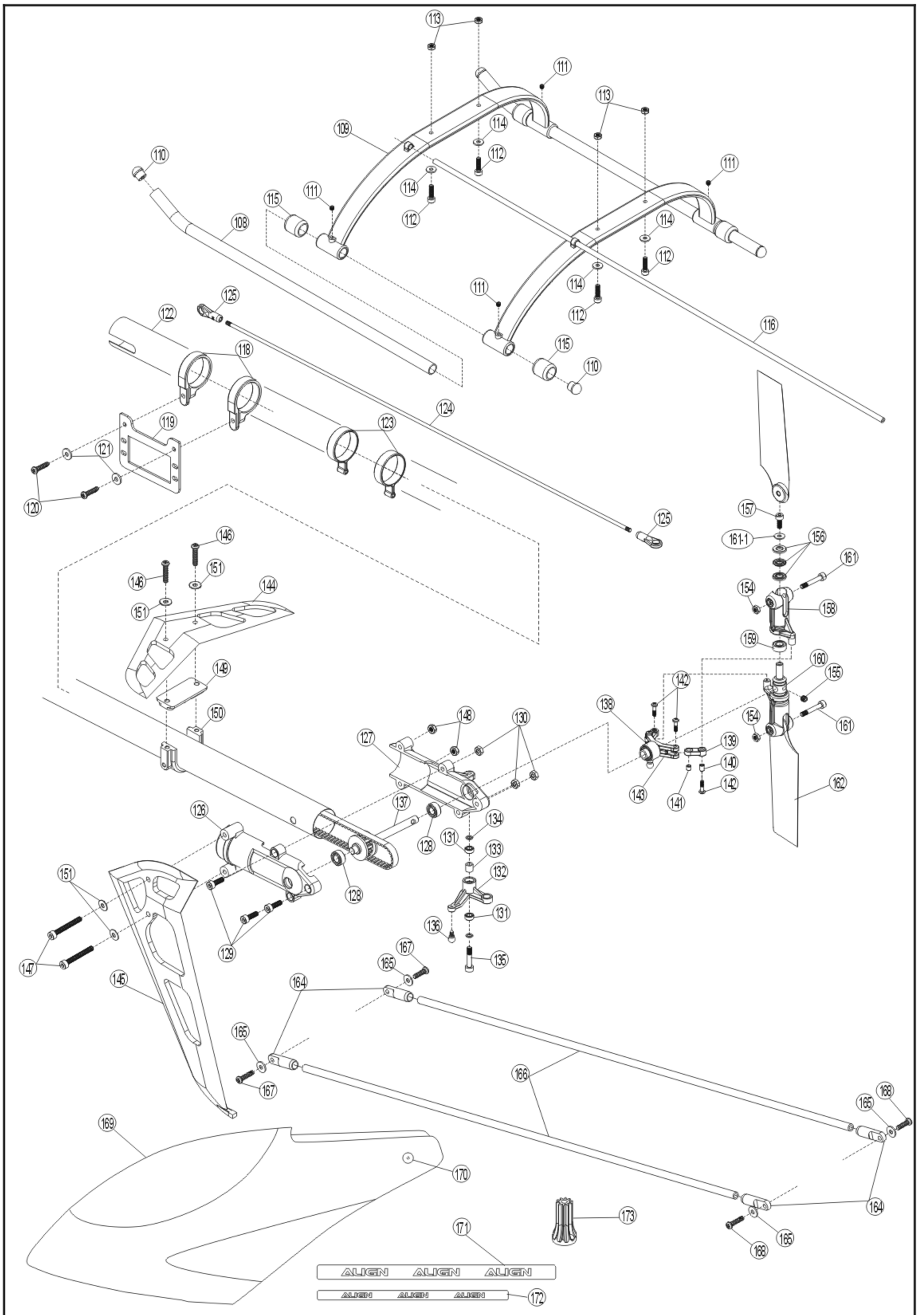

No.	Code No.	Name	Specification	Quantity	Remarks
108	50F083	Skid pipe 腳架鋁管	φ 9x φ 310mm	2	
109	50F129	3D landing skid 3D腳架		2	
110	50F084	Skid pipe end cap 腳架鋁管保護套		4	
111	T73004	M3 Set screw M3止洩螺絲	M3x4mm	4	
112	T63012	Socket screw 圓頭內六角螺絲	M3x12mm	4	
113	N10030	M3 Nut M3防鬆螺帽	M3	4	
114	W10030	M3 Washer M3華司	φ 3x φ 8x 1mm	4	
115	50F130	Landing skid nut 腳架墊圈		4	
116	50F128	Antenna pipe 天線管	φ 2x φ 4x500mm	1	
118	50T086	Rudder servo mount 尾舵伺服器固定座		2	
119	50T214	GF Rudder servo bracket 玻纖尾舵伺服器板	1.6mm	1	
120	S23010-2	Self tapping screw 圓頭十字自攻螺絲	T3x10mm	2	
121	W10030	M3 Washer M3華司	φ 3x φ 8x 1mm	2	
122	50T085	Tail boom 尾管	φ 20x φ 21.5x625mm	2	
123	50T125-1	Tail control guide 尾控制桿固定環		2	
124	50T133-4	Rudder control rod 尾舵控制連桿	φ 1.96x563mm	1	
125	50Z124	Ball link 連桿頭		2	
126	50T090	Tail case(L) 尾齒輪座(左)		1	
127	50T091	Tail case(R) 尾齒輪座(右)		1	
128	50TMR 105ZZ	Bearing MR105ZZ MR105ZZ軸承	φ 5x φ 10x4mm	2	
129	T63012	Socket screw 圓頭內六角螺絲	M3x12mm	3	
130	N10030	M3 Nut M3防鬆螺帽	M3	3	
131	HMR63ZZ	Bearing MR63ZZ MR63ZZ軸承	φ 3x φ 6x2.5mm	2	
132	50T096-1	Tail rotor control arm 尾旋翼控制臂		1	
133	50T097	Collar 尾旋翼控制臂鋁套	φ 3x φ 4.9x5mm	1	
134	50H022-2	Washer 華司	φ 3x φ 4.8x0.3mm	2	
135	T63015	Socket collar screw 圓頭內六角軸套螺絲	M3x15mm	1	
136	50H144-1	Linkage ball A(T2.6x3.5) 球頭A(T2.5x3.5)	φ 4.75x8.18mm	1	
137		Tail rotor shaft assembly 尾橫軸組		2	
138		Tail pitch assembly 尾旋翼控制組		1	
139	50T105	Control link 尾控制連桿頭		2	
140	50T106	Collar A 尾連桿頭銅套A	φ 2x φ 3x4mm	2	
141	50T127	Collar B 尾連桿頭銅套B	φ 2x φ 3x3mm	2	
142	T12008-2	Collar screw 軸套螺絲	M2x8mm	4	
143	50T116	T type arm 尾翼控制組T型臂		1	
144	50T118	Horizontal stabilizer 水平翼		1	
145	50T098	Vertical stabilizer 垂直翼		1	
146	S23014-2	Self tapping screw 圓頭十字自攻螺絲	T3x14mm	2	
147	T63026	Socket screw 圓頭內六角螺絲	M3x26mm	2	
148	N10030	M3 Nut M3防鬆螺帽	M3	2	
149	50T088-1	Stabilizer mount(Upper) 水平翼固定座(上)		1	
150	50T089-1	Stabilizer mount(Lower) 水平翼固定座(下)		1	
151	W10030	M3 Washer M3華司	φ 3x φ 8x 1mm	4	
154	N10030	M3 Nut M3防鬆螺帽	M3	2	
155	T74004	M4 Set screw M4止洩螺絲	M4x4mm	1	
156	50TF510M	Thrust bearing 止推軸承	F5-10M	2	
157	T63008	Socket screw 圓頭內六角螺絲	M3x8mm	2	
158	50T171	Tail rotor holder 尾旋翼夾座		2	
159	50TMR 105ZZ-1	Bearing MR105ZZ MR105ZZ軸承	φ 5x φ 10x4mm	2	
160	50T172	Tail rotor hub 尾旋翼T型座	φ 11x366mm	1	
161	T63020	Socket collar screw 圓頭內六角軸套螺絲	M3x20mm	2	
161-1	W10030-1	Washer 華司	φ 3x φ 8x0.6mm	2	
162	50T203	3K Carbon fiber tail blade 3K碳纖尾旋翼	3K	2	
164	50T123	Tail boom brace end 尾支撐架接頭		4	
165	W10030	M3 Washer M3華司	φ 3x φ 8x 1mm	4	
166	50T132	Tail boom brace 尾管支撐架	φ 5x460mm	2	
167	S23012-2	Self tapping screw 圓頭十字自攻螺絲	T3x12mm	2	
168	S23010-2	Self tapping screw 圓頭十字自攻螺絲	T3x10mm	2	
169	50B134	Fiberglass canopy 玻纖機頭罩		1	
170	50B135	Canopy nut 機頭罩固定套		2	
171	K10378	Hook & Loop Fastening Tape 魔術帶	15x250mm	2	
172	K10379	Hook & Loop Fastening Tape 魔術帶	10x200mm	3	
173	50M227	Motor pinion gear 14T 14T馬達齒輪		2	

### Specifications & Equipment/規格配備:

Length/機身長: 1160mm(45.67 in)

Height/機身高: 400mm(15.75 in)

Main Blade Length/主旋翼長: 600mm

Main Rotor Diameter/主旋翼直徑: 1350mm(53.15 in)

Tail Rotor Diameter/尾旋翼直徑: 240mm(9.45 in)

Motor Pinion Gear/馬達主齒: 14T(15T optional)

Main Drive Gear/傳動主齒輪: 170T

Autorotation Tail Drive Gear/尾驅動主齒: 180T

Tail Drive Gear/尾翼傳動齒: 40T

Drive Gear Ratio/齒輪傳動比: 1:12.14:4.5/1:11.33:4.5

Weight(w/o main blade)/空機重: 2450g(5.4 lbs)

Flying Weight/全配重: Approx 3300g(7.3 lbs)

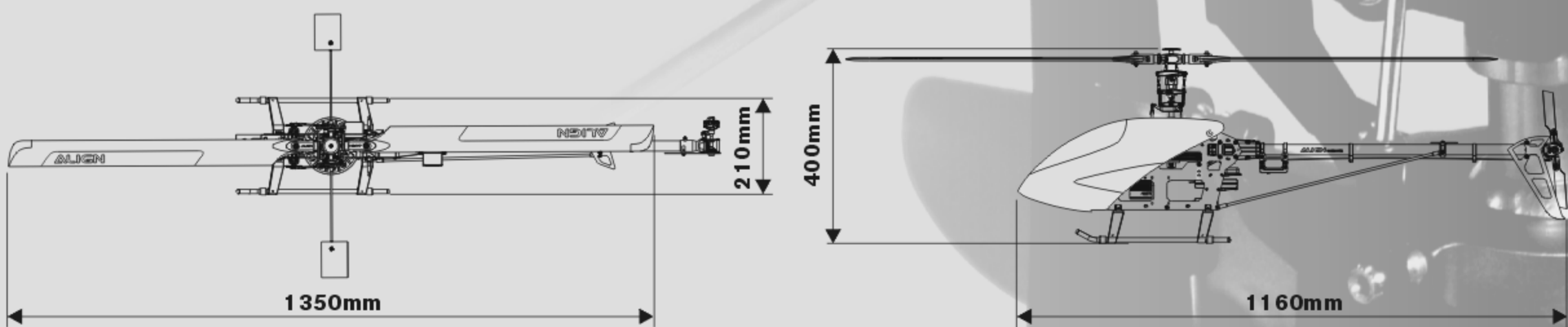

### Features :

Electric Power System | Carbon Fiber Frame | Pre-Painted Fiberglass Canopy | Carbon Fiber Tail Blades | Triple-Bearing Block Main Shaft Support | Fully Driven Tail Auto Rotation System | Tail Rotor Belt Drive System | Push-Pull Control Linkage | Rear Tail Servo Mount | 10mm Hollow Main Shaft, 8mm Spindle