

T-REX 450SE GF

INSTRUCTION MANUAL

使用說明書

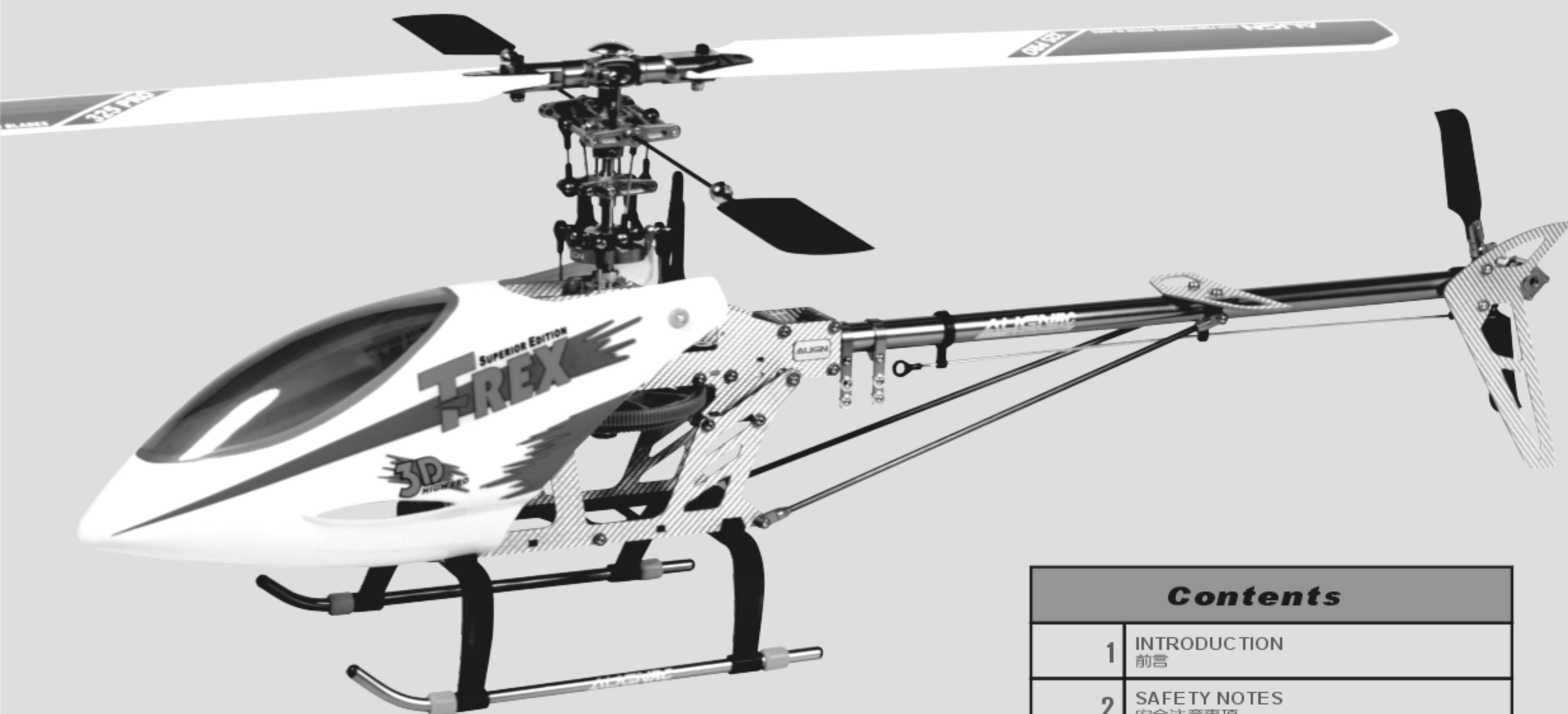

Contents	
1	INTRODUCTION 前言
2	SAFETY NOTES 安全注意事項
3	SAFETY CHECK BEFORE FLYING 飛行前安全檢查
4~13	ASSEMBLY SECTION 組裝說明
14~15	SERVO INSTALLATION 伺服器安裝
16	ELECTRONIC EQUIPMENT AND GYRO INSTALLATION 電子設備與陀螺儀建議安裝位置
17	EQUIPMENT ILLUSTRATION 設備建議配置圖示
17	MAIN ROTOR ADJUSTMENTS 主旋翼平衡與雙槳校正
17	TROUBLESHOOTING THE POWER SYSTEM 動力異常檢查
18	CANOPY ASSEMBLY 機頭罩安裝
19	SERVO SETTING AND ADJUSTMENT 伺服器設定調整
19	ADJUSTMENTS FOR GYRO AND TAIL NEUTRAL SETTING 陀螺儀與尾翼中立點調整
20	PITCH AND THROTTLE SETTING 主旋翼螺距與油門設定
21	POWER COLLOCATION SUGGESTION 動力搭配建議表
21	BRUSHLESS ESC SETTING SUGGESTION 無刷調速器程式設定建議
22~25	FLIGHT ADJUSTMENT AND SETTING 飛行動作調整與設定
26~33	PARTS LIST 零件明細
34	HARDWARE SIZING REFERENCE CHART (ACTUAL SIZE) 五金零件實寸比例名稱對照表

Thank you for buying ALIGN products. The **T-REX 450SE GF** is the latest technology in Rotary RC models. Please read this manual carefully before assembling and flying the new **T-REX 450SE GF** helicopter. We recommend that you keep this manual for future reference regarding tuning and maintenance.

承蒙閣下選用亞拓遙控世界系列產品，謹表謝意。進入遙控世界之前必須告訴您許多相關的知識與注意事項，以確保您能夠在學習的過程中較得心應手。在開始操作之前，請務必詳閱本說明書，相信一定能夠給您帶來相當大的幫助，也請您妥善保管這本說明書，以作為日後參考。

Thank you for buying ALIGN Products. The T-REX 450SE GF Helicopter is designed as an easy to use, full featured Helicopter R/C model capable of all forms of rotary flight. Please read the manual carefully before assembling the model, and follow all precautions and recommendations located within the manual. Be sure to retain the manual for future reference, routine maintenance, and tuning. The T-REX 450SE GF is a new product developed by ALIGN. It features the best design available on the Micro-Heli market to date, providing flying stability for beginners, full aerobic capability for advanced fliers, and unsurpassed reliability for customer support.

感謝您選購亞拓產品，為了讓您容易方便的使用 T-REX 450SE GF 直昇機、請您詳細的閱讀完這本說明書之後再進行組裝以及操作這台直昇機，同時請您妥善的保存這本說明書、作為日後進行調整以及維修的參考。T-REX 450SE GF 是由亞拓自行研發的新產品，不論你是需求飛行穩定性的初學者或是追求性能的飛行愛好者。T-REX 450SE GF 將是你最佳的選擇。

THE MEANING OF SYMBOLS 標誌代表涵義

	Mishandling due to failure to follow these instructions may result in damage or injury. 因為疏忽這些操作說明，而使用錯誤可能造成財產損失或嚴重傷害。
	Mishandling due to failure to follow these instructions may result in danger. 因為疏忽這些操作說明，而使用錯誤可能造成危險。
	Do not attempt under any circumstances. 在任何禁止的環境下，請勿嘗試操作。

IMPORTANT NOTES 重要聲明

R/C helicopters, including the T-REX 450SE GF are not toys. R/C helicopter utilize various high-tech products and technologies to provide superior performance. Improper use of this product can result in serious injury or even death. Please read this manual carefully before using and make sure to be conscious of your own personal safety and the safety of others and your environment when operating all ALIGN products. **Manufacturer and seller assume no liability for the operation or the use of this product.** Intended for use only by adults with experience flying remote control helicopters. After the sale of this product we cannot maintain any control over its operation or usage.



It is not a Toy!

T-REX 450SE GF 遙控直昇機並非玩具，它是結合了許多高科技產品所設計出來的休閒用品，所以商品的使用不當或不熟悉都可能會造成嚴重傷害甚至死亡，使用之前請務必詳讀本說明書，勿輕忽並注意自身安全。注意！任何遙控直昇機的使用，製造商和經銷商是無法對使用者於零件使用的損耗異常或組裝不當所發生之意外負任何責任，本產品是提供給有操作過模型直昇機經驗的成人或有相當技術的人員在旁指導，以確保安全無虞下操作使用，產品售出後本公司將不負任何操作和使用控制上的任何性能與安全責任。

We recommend that you obtain the assistance of an experienced pilot before attempting to fly our products for the first time. A local expert is the best way to properly assemble, setup, and fly your model for the first time. The T-REX 450SE GF requires a certain degree of skill to operate, and is a consumer item. Any damage or dissatisfaction as a result of accidents or modifications are not covered by any warrantee and cannot be returned for repair or replacement. Please contact our distributors for free technical consultation and parts at discounted rates when you experience problems during operation or maintenance.

模型商品屬於操作技術且為消耗性商品，如經拆裝使用後，會造成不等情況零件損耗，任何使用情況所造成商品不良或不滿意，將無法於保固條件內更換新品或退貨，如遇有使用操作維修問題，本公司全省分公司將提供免費技術指導、特價零件供應服務。



Fly only in safe areas, away from other people. Do not operate R/C aircraft within the vicinity of homes or crowds of people. R/C aircraft are prone to accidents, failures, and crashes due to a variety of reasons including, lack of maintenance, pilot error, and radio interference. Pilots are responsible for their actions and damage or injury occurring during the operation or as of a result of R/C aircraft models.

遙控模型飛機、直昇機屬高危險性商品，飛行時務必遠離人群，人為組裝不當或機件損壞、電子控制設備不良，以及操控上的不熟悉、都有可能導致飛行失控損傷等意外，請飛行者務必注意飛行安全，並需了解自負任何意外之責任。

RADIO TRANSMITTER AND ELECTRONIC EQUIPMENT REQUIRED FOR ASSEMBLY 自備遙控及電子設備

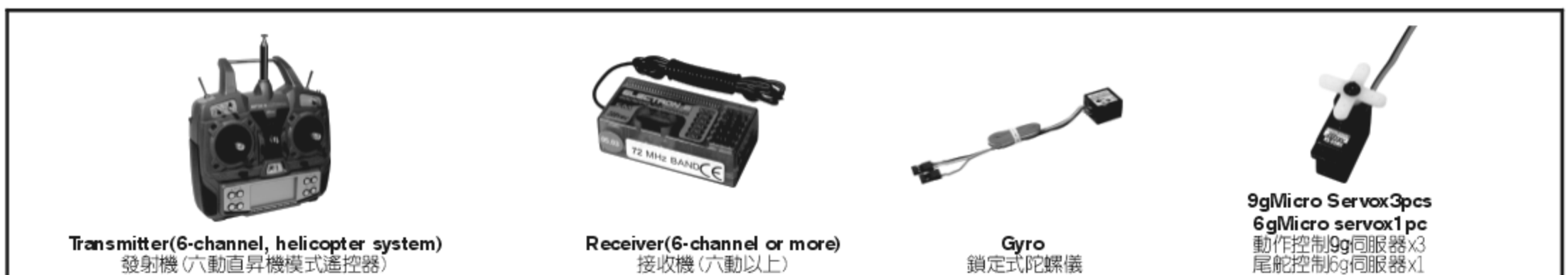

ADDITIONAL TOOLS REQUIRED FOR ASSEMBLY 自備工具

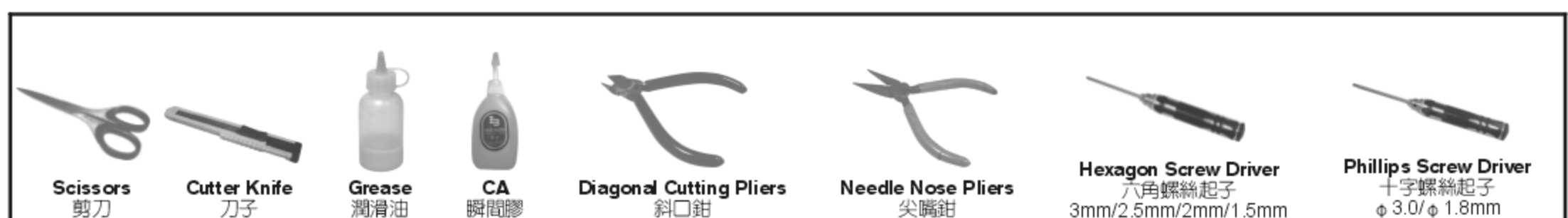



LOCATE AN APPROPRIATE LOCATION 遠離障礙物及人群

R/C helicopters fly at high speed, thus posing a certain degree of potential danger. Choose an appropriate flying site consisting of flat, smooth ground, a clear open field, or a large open room, such as gymnasium or warehouse without obstacles. Do not fly near buildings, high voltage cables, or trees to ensure the safety of yourself, others, and your model. Do not fly your model in inclement weather, such as rain, wind, snow or darkness.

直昇機飛行時具有一定的速度，相對的也潛在著一點危險性，場地的選擇也相對的重要。首先必須注意周遭有沒有人、高樓、建築物、高壓電線、樹木等等，避免操控的不當造成自己與他人財產的損壞。初次練習時，務必選擇在空曠場地並可適當搭配練習架練習飛行，這對飛行失誤所造成的損傷將會大幅的降低。請勿在下雨、打雷等惡劣天候下操作，以確保本身及機體的安全。



OBTAIN THE ASSISTANCE OF AN EXPERIENCED PILOT 避免獨自操控

Before turning on your model and transmitter, check to make sure no one else is operating on the same frequency. Frequency interference can cause your model, or other models to crash. The guidance provided by an experienced pilot will be invaluable for the assembly, tuning, trimming, and actual first flight. (Recommend you to practice with computer-based flight simulator.)

至飛行場飛行前，需確認是否有相同頻率的同好正進行飛行，因為開啓相同頻率的發射機將導致自己與他人立即干擾等意外危險。遙控飛機操控技巧在學習初期有著一定的難度，要盡量避免獨自操作飛行，需有經驗的人士在旁指導，才可以操控飛行。
(勤練電腦模擬器及老手指導是入門必要的選擇)

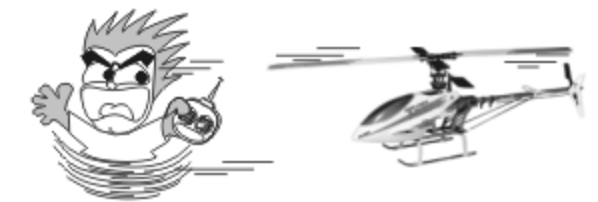

ALWAYS BE AWARE OF THE ROTATING BLADES 遠離運轉中零件

During the operation of the helicopter, the main rotor and tail rotor will be spinning at a high rate of speed. The blades are capable of inflicting serious bodily injury and damage to the environment. Be conscious of your actions, and careful to keep your face, eyes, hands, and loose clothing away from the blades. Always fly the model a safe distance from yourself and others, as well as surrounding objects. Never take your eyes off the model or leave it unattended while it is turned on. Immediately turn off the model and transmitter when you have landed the model.

當直昇機主旋翼與尾旋翼運轉時，切勿觸摸並遠離任何物件，以避免造成危險及損壞。



PREVENT MOISTURE 遠離潮濕環境

R/C models are composed of many precision electrical components. It is critical to keep the model and associated equipment away from moisture and other contaminants. The introduction or exposure to water or moisture in any form can cause the model to malfunction resulting in loss of use, or a crash. Do not operate or expose to rain or moisture.

直昇機內部也是由許多精密的電子零組件組成，所以必須絕對的防止潮濕或水氣，避免在浴室或雨天時使用，防止水氣進入機身內部而導致機件及電子零件故障而引發不可預期的意外！



KEEP AWAY FROM HEAT 遠離熱源

R/C models are made up various forms of plastic. Plastic is very susceptible to damage or deformation due to extreme heat and cold climate. Make sure not to store the model near any source of heat such as an oven, or heater. It is best to store the model indoors, in a climate-controlled, room temperature environment.

遙控飛機多半是以 PA 纖維或聚乙烯、電子商品為主要材質，因此要盡量遠離熱源、日曬，以避免因高溫而變形甚至熔毀損壞的可能。



PROPER OPERATION 勿不當使用本產品

Please use the replacement of parts on the manual to ensure the safety of instructors. This product is for R/C model, so do not use for other purpose.

請勿自行改造加工，任何的升級改裝或維修，請使用亞拓產品目錄中的零件，以確保結構的安全。請確認於產品限界內操作，請勿過載使用，並勿用於安全、法令外其它非法用途。



SAFE OPERATION 安全操作

Operate this unit within your ability. Do not fly under tired condition and improper operation may cause in danger.

請於自己能力內及需要一定技術範圍內操作這台直昇機，過於疲勞、精神不佳或不當操作，意外發生風險將可能會提高。



CAREFULLY INSPECT BEFORE REAL FLIGHT 實機飛行前請嚴格執行飛行前檢查義務

- ☆ Before flying, please check to make sure no one else is operating on the same frequency for the safety.
- ☆ Before flight, please check if the power of transmitter and helicopter are enough for the flight.
- ☆ Before turn on the transmitter, please check if the throttle stick is in the lowest position. IDLE switch is OFF.
- ☆ When turn off the unit, please follow the power on/off procedure. Power ON- Please turn on the transmitter first, and then turn on helicopter power. Power OFF- Please turn off the helicopter power first and then turn off the transmitter. Improper procedure may cause out of control, so please to have this correct habit.
- ☆ Before operation, check every movement is smooth and directions are correct. Carefully inspect servos for interference and broken gear.
- ☆ Check for missing or loose screws and nuts. See if there is any cracked and incomplete assembly of parts. Carefully check main rotor blades and rotor holders. Broken and premature failures of parts possibly cause resulting in a dangerous situation.
- ☆ Check all ball links to avoid excess play and replace as needed. Failure to do so will result in poor flight stability.
- ☆ Check the battery and power plug are fastened. Vibration and violent flight may cause the plug loose and result out of control.
- ☆ Check for the tension of tail drive belt.

- ★ 每次飛行前應先確認所使用的頻率是否會干擾他人，以確保你自身與他人的安全。
- ★ 每次飛行前確定您發射機與直昇機電池的電量是在足夠飛行的狀態。
- ★ 開機前確認油門搖桿是否位於最低點，熄火降落開關，定速開關 (IDLE) 是否於關閉位置。
- ★ 關機時必須遵守電源開關機的程序，開機時應先開啓發射機後，再開啓直昇機電源；關機時應先關閉直昇機電源後，再關閉發射機電源。不正確的開關機程序可能會造失控的現象，影響自身與他人的安全，請養成正確的習慣。
- ★ 開機請先確定直昇機各個動作是否順暢，及方向是否正確，並檢查伺服器的動作是否有干涉或崩齒的情形，使用故障的伺服器將導致不可預期的危險。
- ★ 飛行前確認沒有缺少或鬆脫的螺絲與螺帽，確認沒有組裝不完整或損毀的零件，仔細檢查主旋翼是否有損壞，特別是接近主旋翼夾座的部位。損壞或組裝不完整的零件不僅影響飛行，更會造成不可預期的危險。注意：對損耗、有裂痕零件更新及定期保養檢查重要性。
- ★ 檢查所有的連桿頭是否有鬆脫的情形，過鬆的連桿頭應先更新，否則將造成直昇機無法操控的危險。
- ★ 確認電池及電源接頭是否固定牢靠，飛行中的震動或激烈的飛行，可能造成接頭鬆脫而造成失控的危險。
- ★ 確定尾傳動皮帶的鬆緊度。

Standard Equipment 標準配備



When you see the marks as below, please use glue or grease to ensure flying safety.

標有下符號之組裝步驟，請配合上膠或上油，以確保使用之可靠度。



- CA: Apply CA Glue to fix.
- R48: Apply Anaerobics Retainer to fix.
- T43: Apply Thread Lock to fix.
- OIL: Add Grease.
- CA: 使用瞬間膠固定
- R48: 使用金屬管狀固定缺氧膠固定
- T43: 使用螺絲缺氧膠
- OIL: 添加潤滑油

When assembling ball links, make sure the "A" character faces outside.

各項塑膠製連桿頭扣接時，A字請朝外。

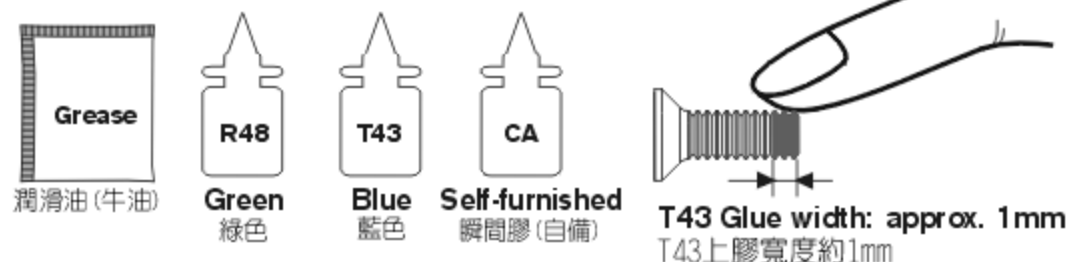

R48 metal tubular adhesive (eg. Bearings). T43 thread lock, apply a small amount on screws or metal parts and wipe surplus off. When disassembling, recommend to heat the metal joint about 15 Seconds. (NOTE: Keep plastic parts away from heat.)
R48 為強力金屬管狀 (如軸承) 接著劑，T43為螺絲膠，膠合螺絲或金屬內外徑請務必少量使用，必要時請用手去除多餘膠量，欲拆卸時可於金屬接合部位熱烤約15秒。(注意！塑膠件避免接近熱源)

HH

★Insert the main rotor housing diagonally into the flybar seesaw holder.
★請將主旋翼固定座以對角方式裝入平衡桿固定座。



When tightening a linkage ball to a plastic part, please note to use a little CA glue and tighten it firmly, but not over tightened, or they will strip.
球頭鎖入塑膠件請務必注意，使用少量CA膠並適當扭力鎖緊即可，而過緊的扭力可能會導致滑牙。

For original manufactory package, if the product is already assembled by Factory, please check again if screws are firmly secured and applied with some glue.
原廠零件出廠包裝如果是組裝品，請需再確認各螺絲是否鎖緊上膠。

When tightening a screw to a plastic part, please tighten it firmly, but not over tightened, or they will strip.
螺絲鎖入塑膠件請務必注意，適當扭力鎖緊即可，而過緊的扭力可能會導致滑牙。

Make sure the mount can slide up and down smoothly and freely
固定座上下保持搖動順暢。

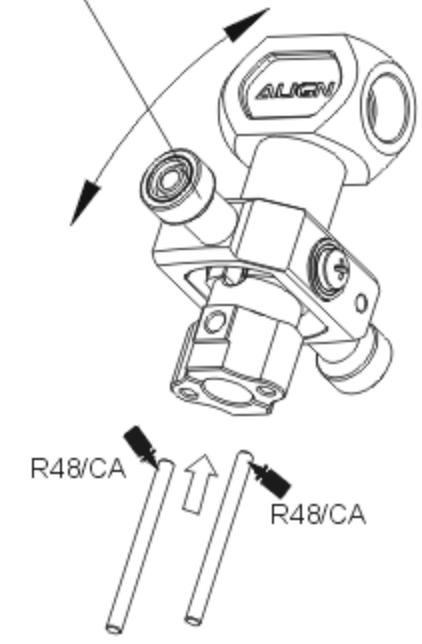

Metal main rotor housing
金屬主旋翼固定座
17x37.5x11mm

Pin
定位插銷
φ 1.5x18.7mm

Metal flybar seesaw holder
金屬平衡桿固定座
36x14.5x7mm

Collar screw
轉套螺絲
M2x8mm

Washer
華司
φ 2x φ 3.6x0.2mm

Socket button
head collar screw
半圓頭內六角轉套螺絲
M2x5.5mm

Bearing MR52ZZ
轉承MR52ZZ
φ 2x φ 5x2.5mm

Already assembled
已裝入
Bearing MR52ZZ
轉承MR52ZZ
φ 2x φ 5x2.5mm

Make sure the linkage balls are tightly secured.
務必將每顆金屬球頭鎖緊上緊螺絲，不可鬆動。

Washer
華司
φ 2x φ 3.6x0.2mm

Bearing FMR52ZZ
轉承FMR52ZZ
φ 2x φ 5x φ 6x2.3mm

Already assembled
已裝入

Bearing MR52ZZ
轉承MR52ZZ
φ 2x φ 5x2.5mm

Linkage ball A (M2x2.5)
球頭A (M2x2.5)
φ 4.75x7.18mm

Washer
華司
φ 2x φ 3.6x0.2mm

Washer
華司
φ 2x φ 3.6x0.5mm

Metal SF mixing arm
金屬SF控制搖臂
31.45x5.5mm

Collar screw
轉套螺絲
M2x8mm

Make sure the arms move smoothly and freely.
螺絲鎖緊時需讓SF搖臂轉動順暢

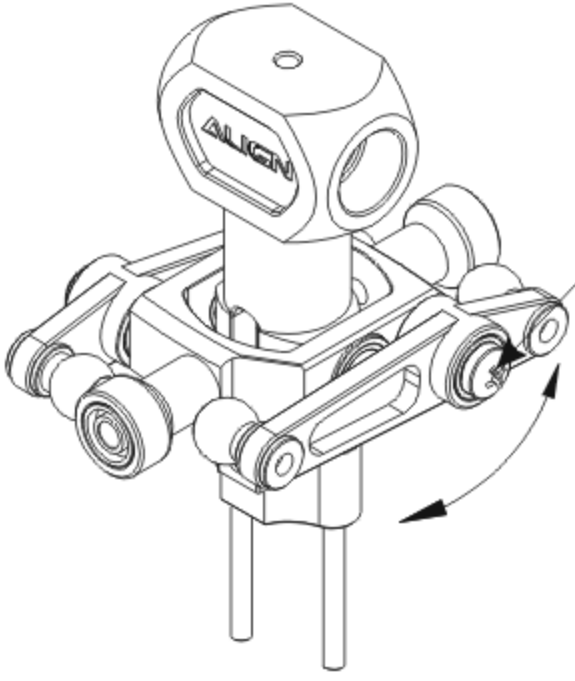

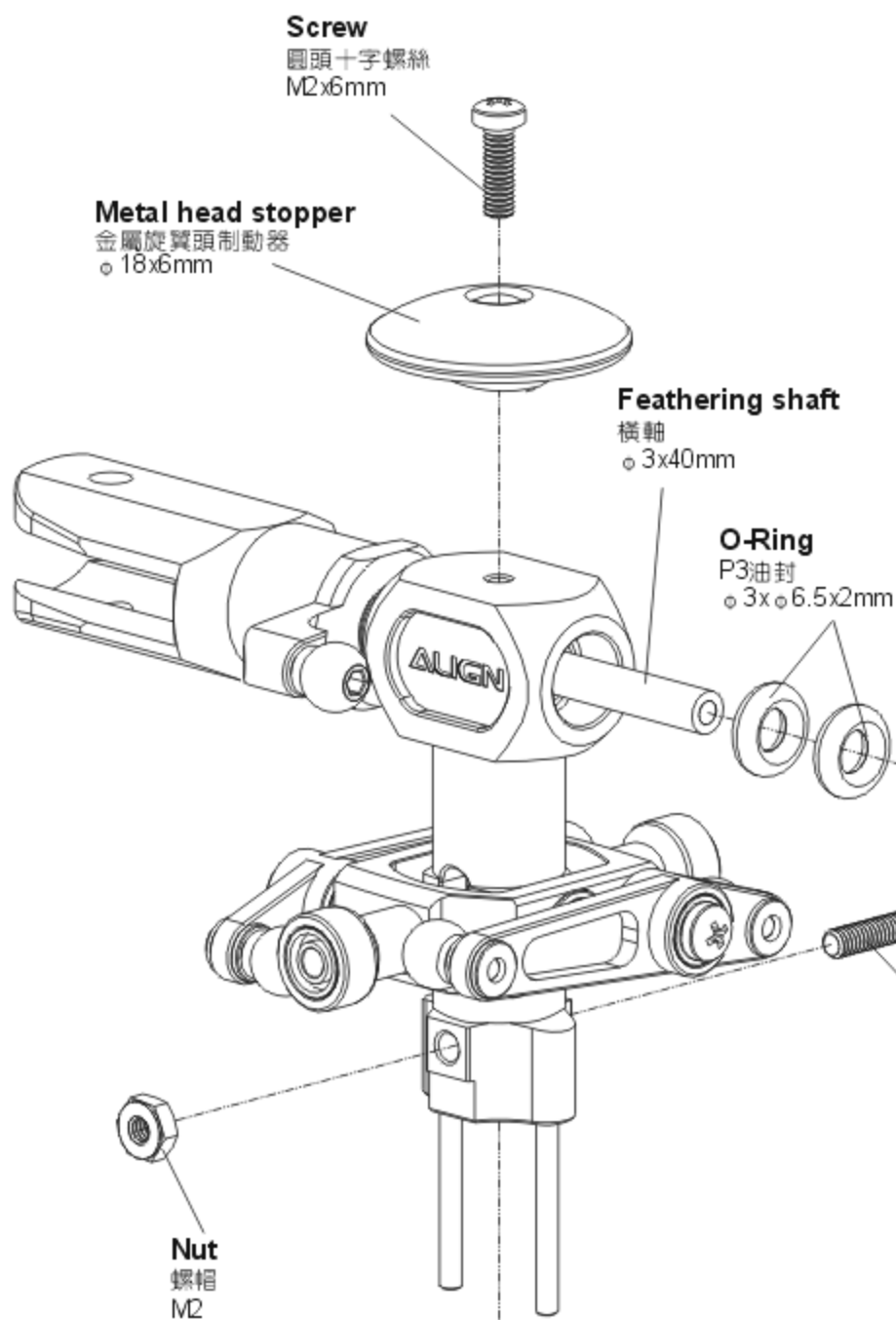
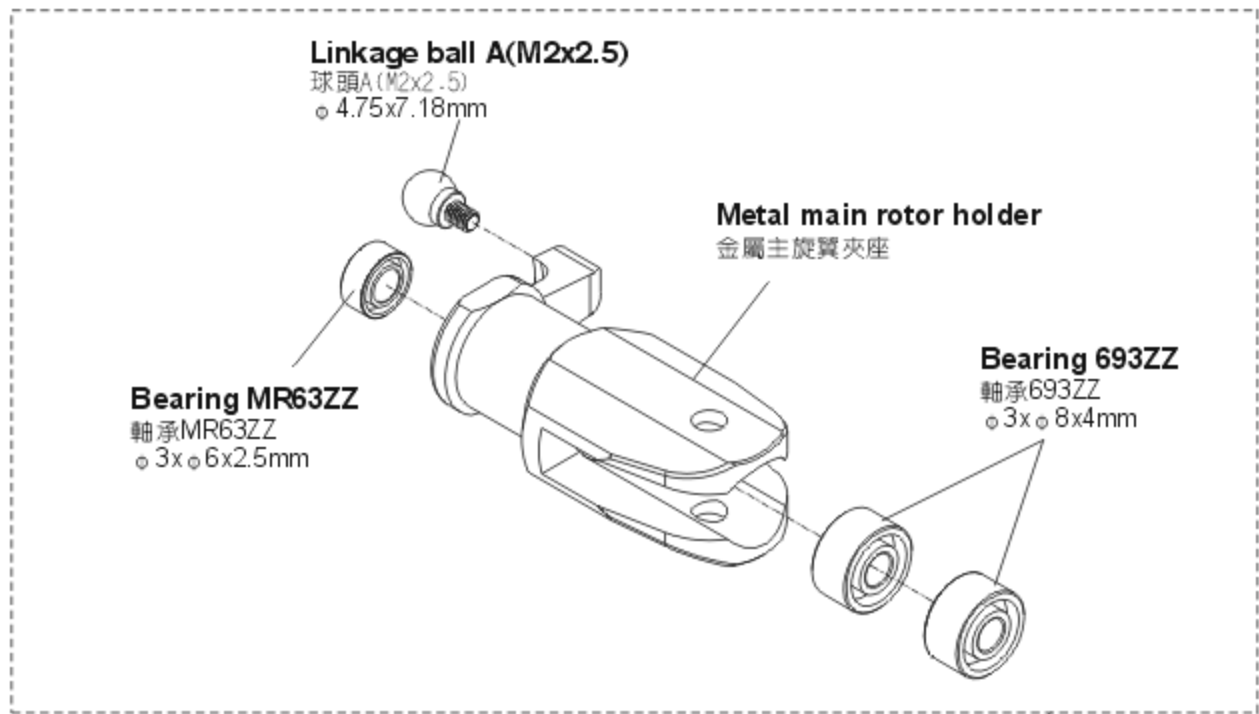

3X5X1.5 Use for Normal flight, suitable for beginners.
適用於一般飛行，適合初階者使用

3X5X2.5 Use for 3D and aerobatic flight, suitable for advanced pilots.
適用於3D飛行，適合高階者使用

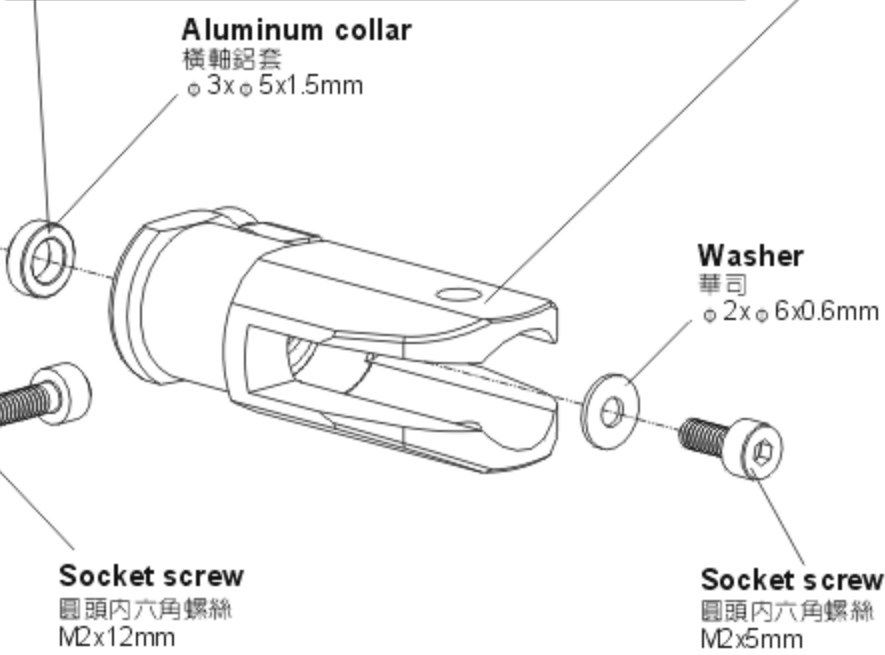

Longer length
4.8mm faces up.
較長孔中心距
4.8mm朝上

Main shaft
主軸
ø 5x116mm

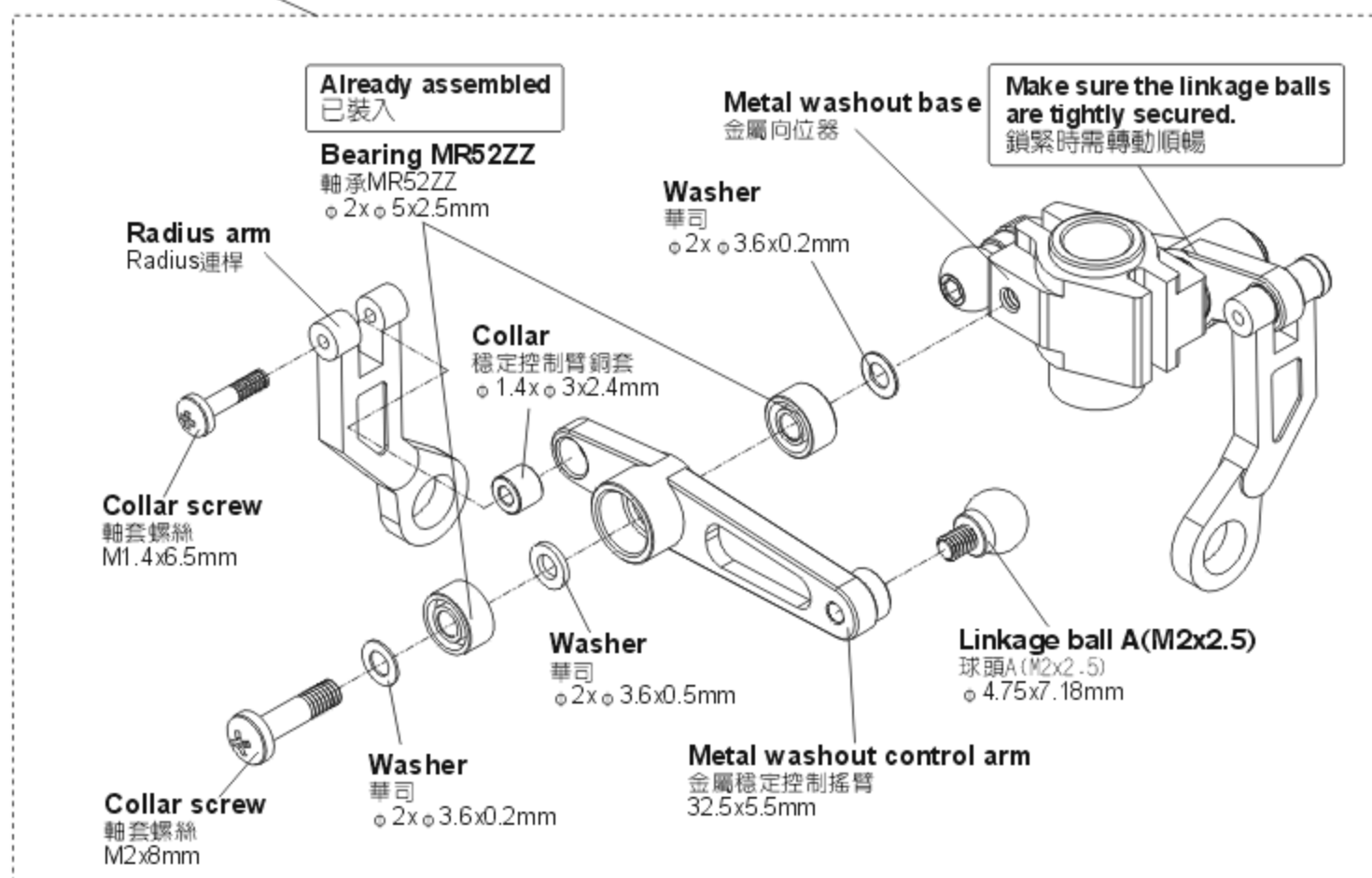

HH4

Metal main rotor head assembly 金屬主旋翼組

Already assembled by factory,
please note to check again.
已組裝完成，飛行前請務必自行再確認
檢查各螺絲是否黏膠鎖緊。

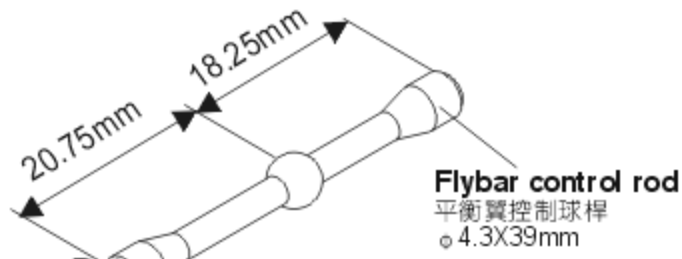
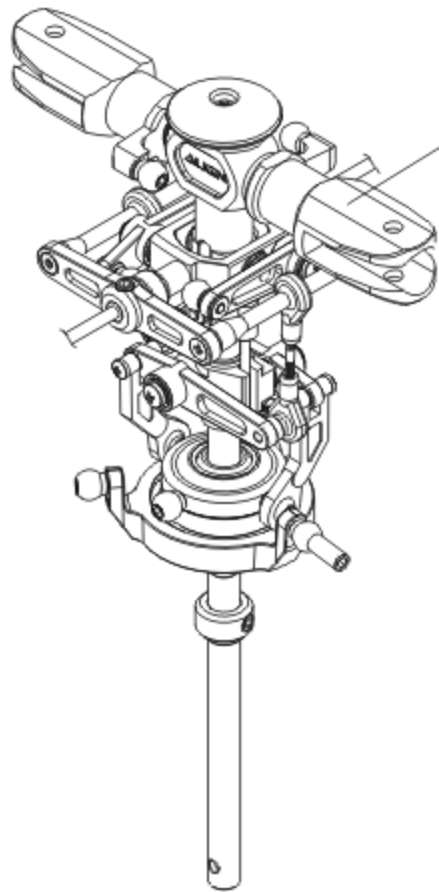

Set screw
止洩螺絲
M3x3mm

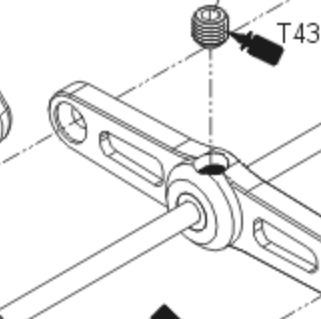

Cross screw
皿頭十字螺絲
M2x5mm

CCPM Swashplate
CCPM十字盤組
φ26X11.5mm

Lock ring
主軸固定套
φ5X6mm

Cross screw
皿頭十字螺絲
M2x5mm

Flybar rod
平衡翼桿
φ1.97X220mm

T43

T43

T43

T43

T43

Set screw
止洩螺絲
M3x3mm

Assemble linkage rod(B) before
assembling flybar control set.
組裝平衡翼控制組前將B連接桿裝入。

Approx 23.5mm
約23.5mm

X2

HH4

For more stable flight, install the flybar weights as shown.
For more Acrobatic flight, the flybar weights are not required.
一般飛行時可於副翼加重，藉以提昇飛行穩定性。
特技飛行時即不需加重，可展現3D動作的靈活性。

Set screw
止洩螺絲
M3x3mm

T43

Flybar weight
平衡翼重錘
φ7.5X8mm

Flybar paddle
平衡翼

R48

84.4mm

84.4mm

Make sure both sides are equal in length
平衡桿須調整等邊長度約77mm

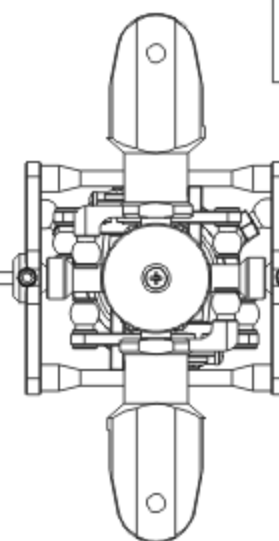

Approx. 77mm
約77mm



Rotate in a clockwise direction.
順時針旋轉

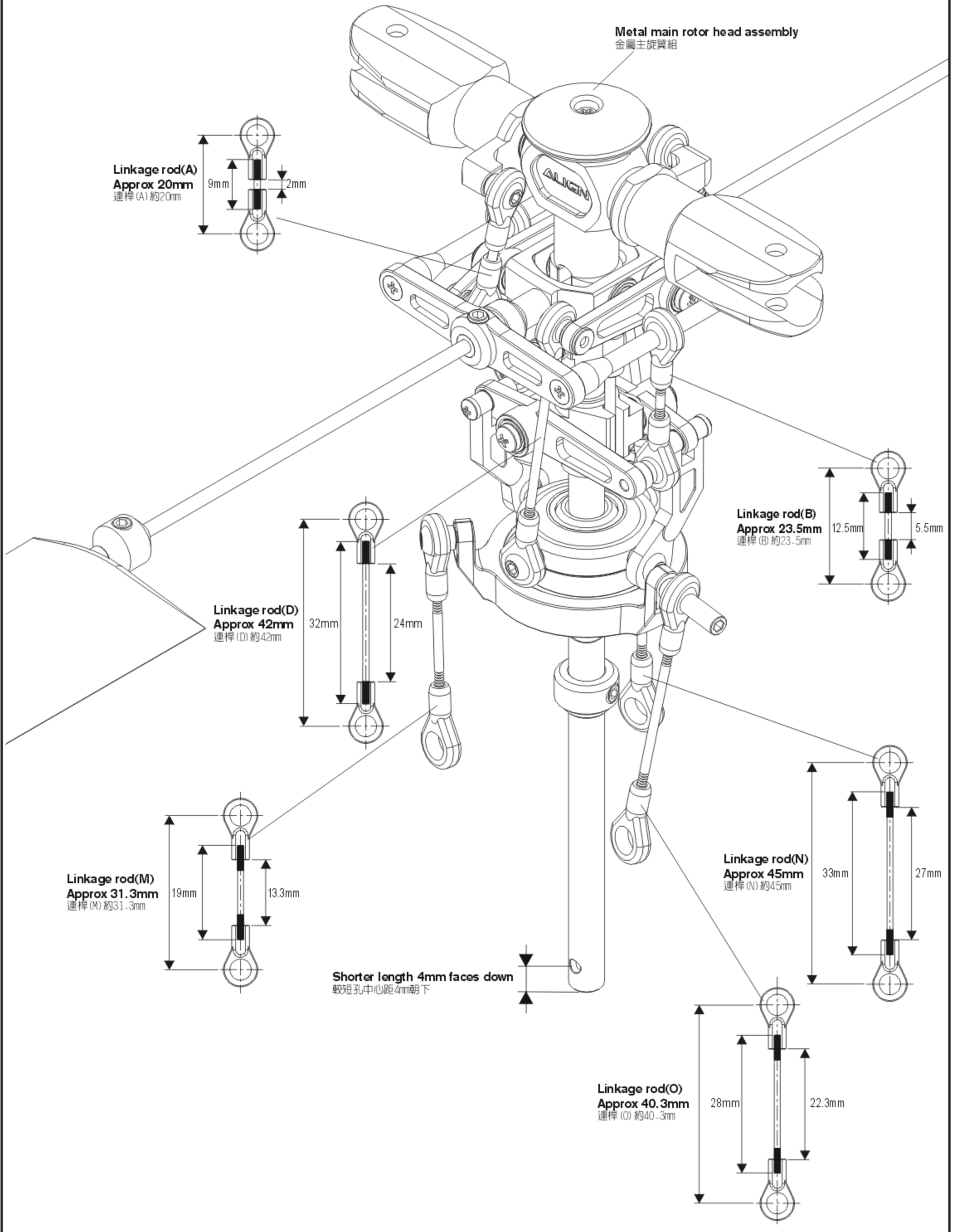

HB2

The screws must be firmly tightened, but not over tightened, or they will strip and become loose. Apply screwlok where screws are tightened into metal objects.

組裝側板時所使用的螺絲可視需要使用螺絲防鬆膠，要特別注意的是：螺絲必須確實鎖緊，但是要小心不能過度鎖緊，以避免發生滑牙或斷裂現象。

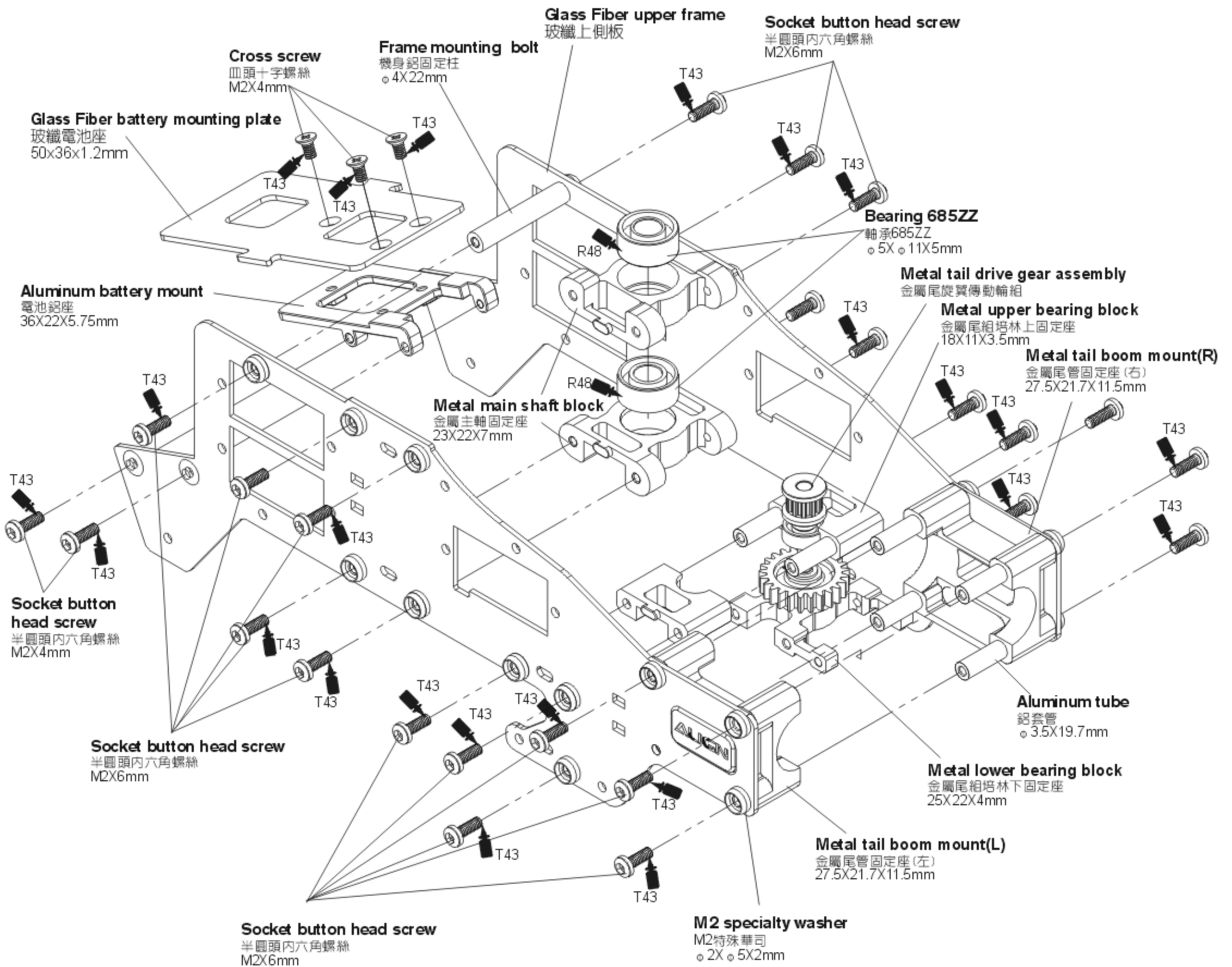

Make sure the frames are tightly secured without gaps.
組裝後需檢查左右主體間不可有間隙，確保被鎖固不鬆動。

Please check if the main shaft rotates smooth after assembling the main frames.
機體組裝後請注意主軸需滑順

Already assembled by factory, please note to check again.
已組裝完成，飛行前請務必自行再確認檢查各螺絲是否點膠鎖緊。

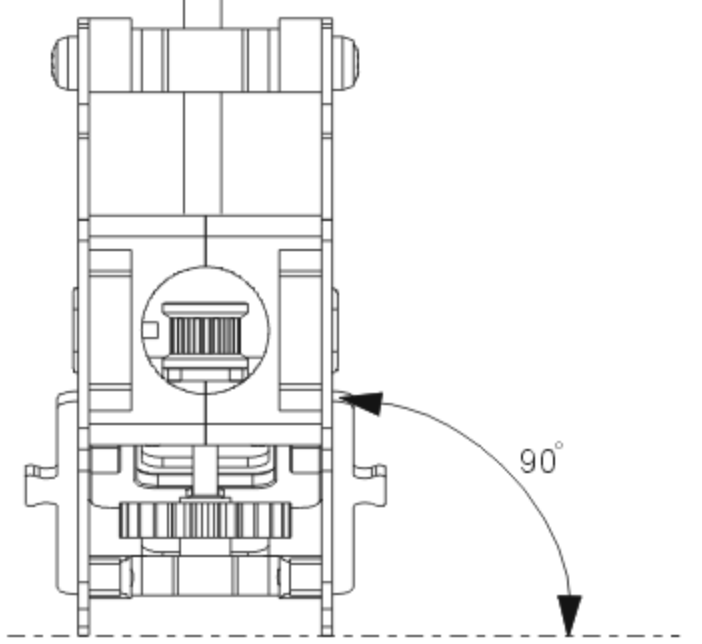

Please note vertical angle when assembling.
(組裝主體側板須注意直角度)

Glass Fiber lower frame
玻璃下側板

Bottom plate
底板
172.5X39X5mm

M2 specialty washer
M2特殊華司
ø2X ø5X2mm

Socket button head self tapping screw
半圓頭內六角鐵板螺絲
T2X6mm

Already assembled by factory,
please not to check again.
已組裝完成，飛行前請務必自行再確
認檢查各螺絲是否黏膠鎖緊。

Recommend sanding the marked position as below
illustration with a waterproof abrasive paper(#800-1000)
to avoid the wires of electric parts to be cut.
建議於下圖色塊標示處，使用#800-1000水砂紙打磨，可防止電子
設備電線被割破。

Waterproof abrasive paper
水砂紙

Frame mounting bolt
機身鋁固定柱
ø4X22mm

Aluminum link
上下側板接合鋁柱
ø2X ø5X7.5mm

Metal motor mount
金屬馬達固定座
36.4X39mm

Main frame assembly
機身組

Socket button head screw
半圓頭內六角螺絲
M2X14mm

Socket button head screw
半圓頭內六角螺絲
M2X14mm

Socket button head screw
半圓頭內六角螺絲
M2X6mm

M2 specialty washer
M2特殊華司
ø2X ø5X2mm

Socket button head screw
半圓頭內六角螺絲
M2X14mm

HB2

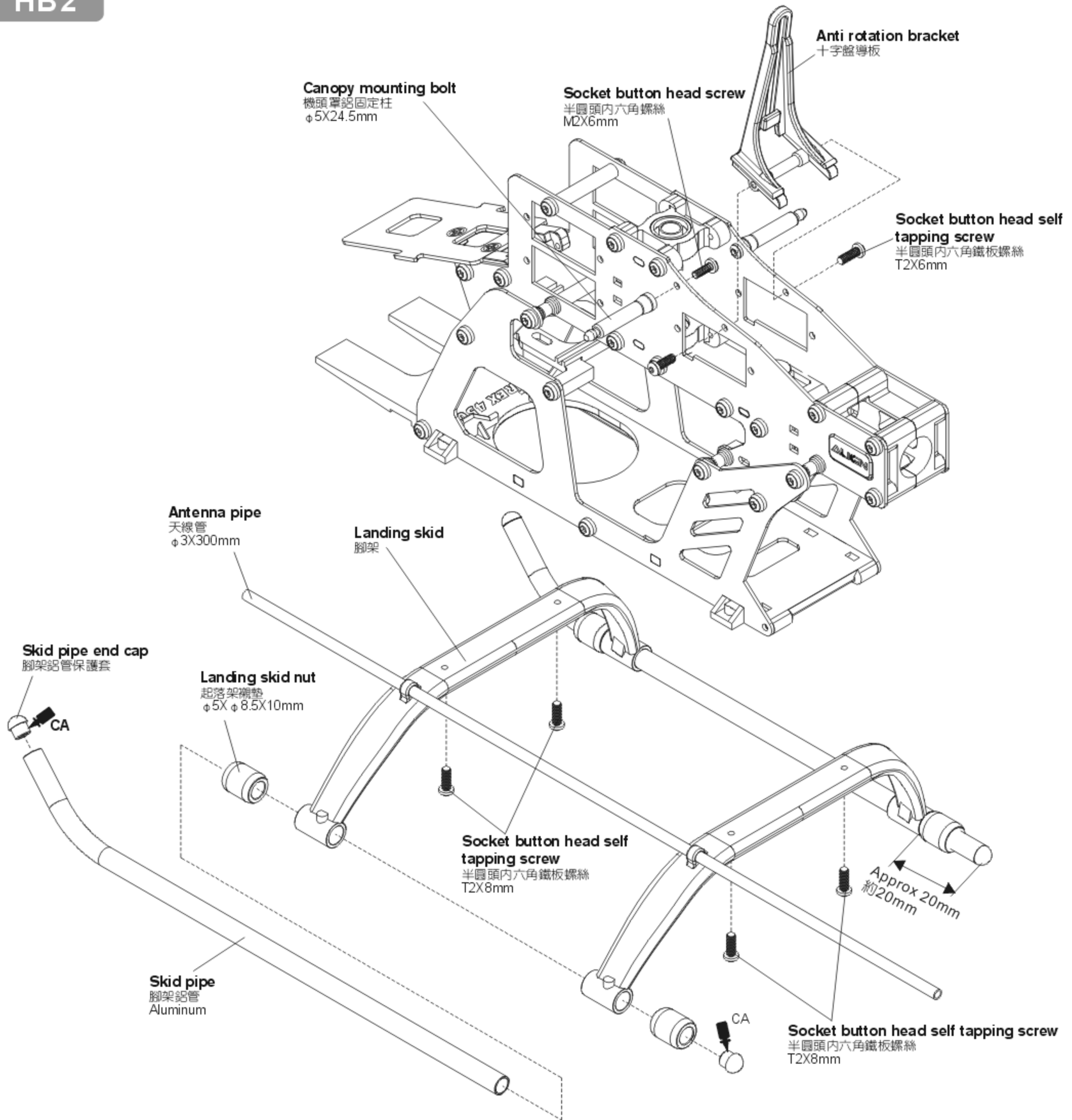

HB6

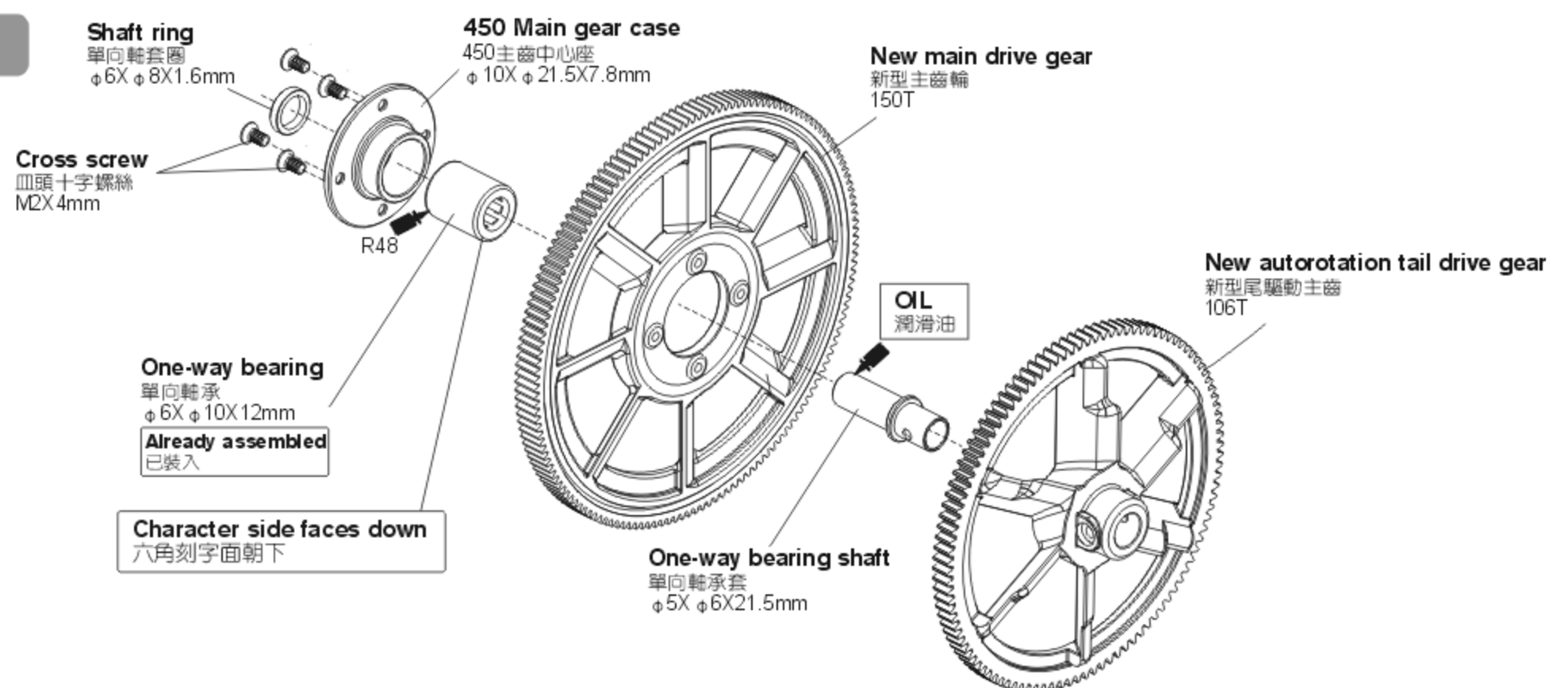

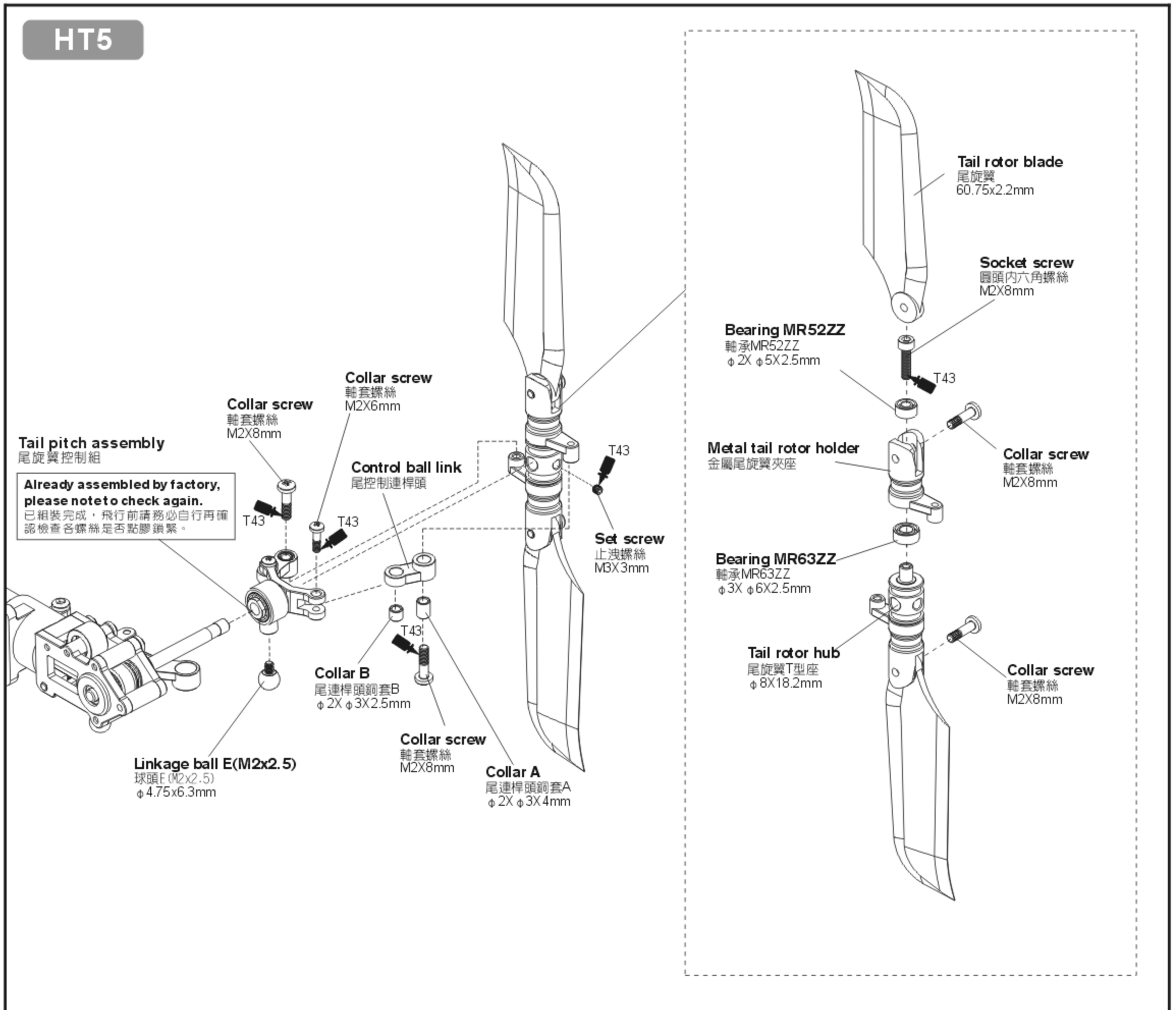
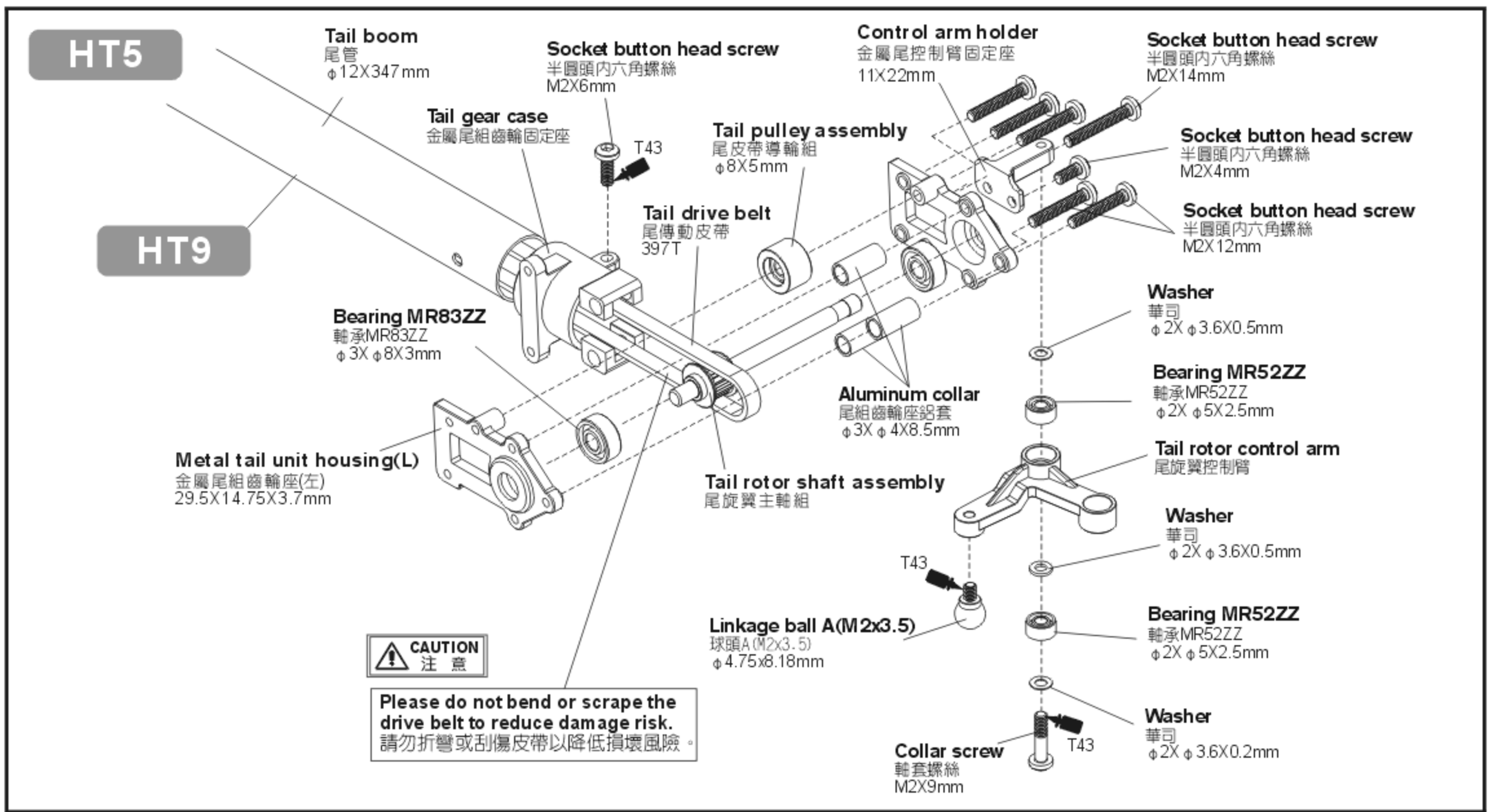

HT3

CAUTION 注意

Tail boom brace end
尾管支撐架接頭

Tail boom brace
尾管支撐架
φ3X205mm

Apply some glue on tail boom brace ends to avoid vibration. When gluing, note the two ends must be parallel to each other, or they can't be fixed flat. 尾支撐架接頭上膠，如果不上膠，可能導致震動。上膠時請注意前後接頭必須平行，否則會有無法平貼鎖附的情形。

HT9

Please do not tighten the screws before assembling tail boom.
裝尾管前螺絲請勿上緊

CAUTION 注意

Aim the opening of tail boom at the convex of the tail boom mount and insert.
瞄準尾管上的凹槽和尾座凸出，並插入。

HT9

Please insert the opening of tail boom into the convex.
尾管缺口方向裝入時，請導入尾管座卡榫內。

Socket button head screw
半圓頭內六角螺絲
M2X6mm

Metal tail servo mount
金屬尾伺服器座

Socket button head self tapping screw
半圓頭內六角鐵板螺絲
T2X8mm

Glass Fiber horizontal stabilizer
玻纖水平翼

M2 specialty washer
M2特殊華司
φ2X φ5X2mm

Washer
華司
φ2X φ6X0.6mm

Washer
華司
φ2X φ6X0.6mm

Tail boom brace end
尾管支撐架接頭

M2 specialty washer
M2特殊華司
φ2X φ5X2mm

Collar screw
轉套螺絲
M2X9mm

Tail boom brace
尾管支撐架
φ3X205mm

HT9

Tail control guide
尾控制桿固定環

Stabilizer mount
水平翼固定座

M2 specialty washer
M2特殊華司
φ2X φ5X2mm

Socket button head self tapping screw
半圓頭內六角鐵板螺絲
T2X8mm

Tail rotor assembly
尾翼組

M2 specialty washer
M2特殊華司
φ2X φ5X2mm

T43

T43

Socket button head screw
半圓頭內六角螺絲
M2X6mm

Glass Fiber vertical stabilizer
玻纖垂直直翼

CAUTION 注意

Drive belt illustration 尾傳動皮帶裝配圖示

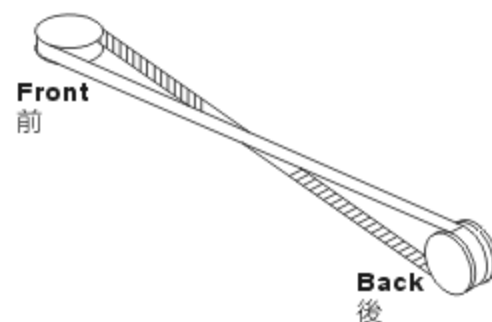

1. Check to rotate the belt 90 degrees when assembling.
2. Belt tension: Recommend to lightly tighten the drive belt after assembling tail boom to avoid vibration, belt friction and rotation slip.

1. 組裝時確認皮帶順轉90°。
2. 皮帶緊度：建議尾管組裝後皮帶請稍微拉緊，避免震動皮帶摩擦或轉動打滑。

HH3

325 Blade
325 主旋翼
325mm

Socket screw
圓頭內六角螺絲
M3x14mm

Nut
防鬆螺帽
M3

Socket screw
圓頭內六角螺絲
M2.6x6mm

For motor fixing
馬達固定螺絲

Washer
華司
φ2.6xφ6mm

Standard Belt Tension Guide:

Visualize a straight line through the center of the main drive gear. You should be able to apply light tension to the belt with your finger until it reaches a point 3/4 of the way to the opposite edge of the main gear, or 1/4 of the way past the virtual center of the main gear. Refer to photo.

皮帶緊度標準：
皮帶輕壓單邊可達傳動輪中心線以下3/4為標準。
(較鬆皮帶調整將對動力提升有幫助)

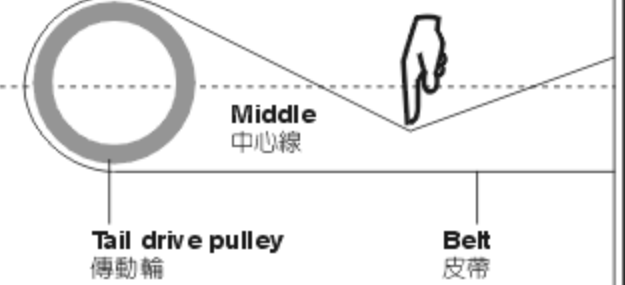

Set the motor pinion gear to main drive gear mesh to approximately 0.1mm to avoid excess power consumption or motor burnt due to overload.
馬達前後可移動以保持兩齒輪咬合處約有0.1mm間隙，過緊齒咬合將造成動力損失或馬達高阻力的過載，嚴重可能導致馬達燒毀。

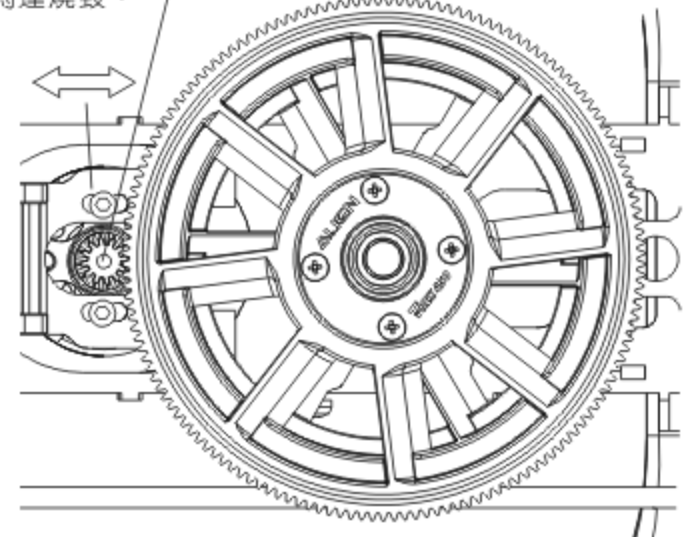

Motor pinion gear 12T for hovering, general, 3D flights.
Motor pinion gear 13T for hard 3D flight.
12T馬達主齒 一般飛行停懸、空中、3D飛行模式
13T馬達主齒 暴力3D飛行模式

Set screw
止洩螺絲
M3x3mm

T43

Motor
馬達
3550KV

1. Please prepare three micro servos (9g) for CCPM swashplate control and one quick speed (0.12sec/within 60 degrees) micro servo (6~9g) for tail rudder control. First remove the servo horn from the three servos for swashplate.

請準備3個型號相同的小型伺服器(9g)作為CCPM十字盤控制用, 1個速度較快(0.12sec/60度以內)的小型伺服器(6~9g), 作為尾舵控制用; 首先將十字盤控制用伺服器的舵片拆下。

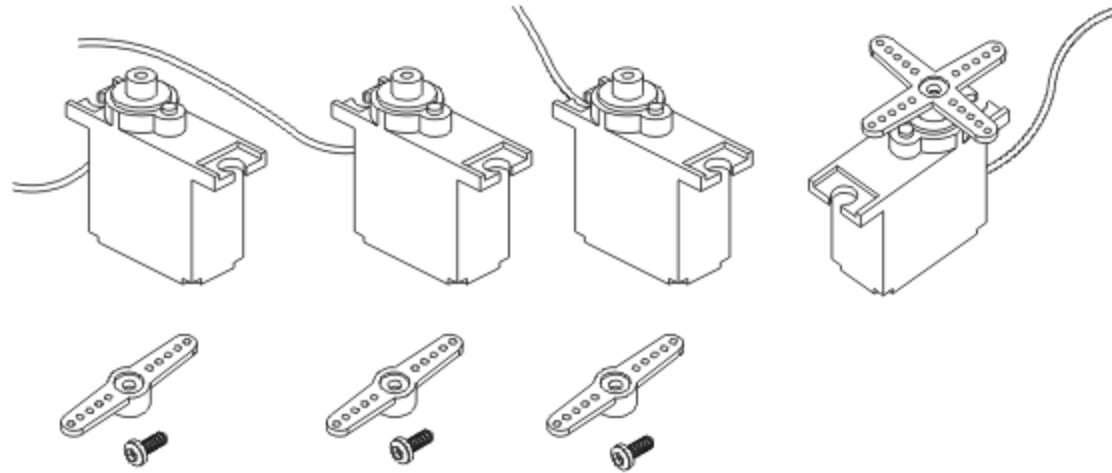

2. Use a 1.5mm Hex wrench, remove the aluminum bolts from the main frames to install the servos. After installation, note to reinstall the aluminum bolts.

使用1.5mm的六角扳手將固定於機身的鋁固定柱暫時拆下, 以便安裝伺服器, 安裝完成後要記得將固定柱裝回。

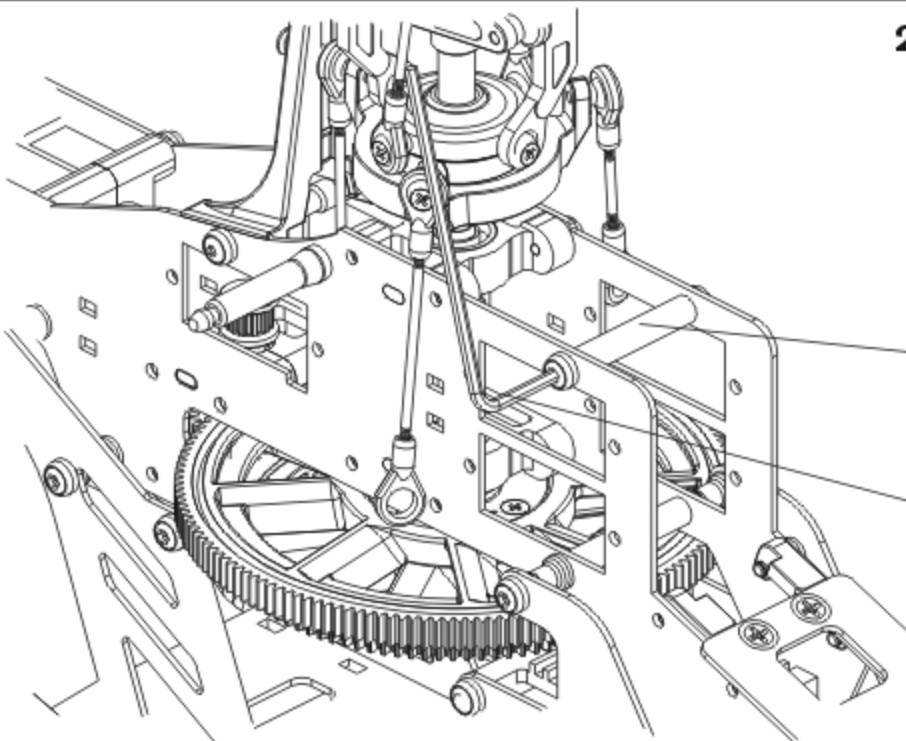

Frame aluminum bolt
機身鋁固定柱

1.5mm Hex wrench
1.5mm六角扳手

3. First install the servo inside the lower mount. Note the output shaft must be oriented toward the rear of the helicopter.

如圖示, 先將伺服器安裝於下方的固定座, 注意伺服器齒輪軸需偏向直昇機の後方。

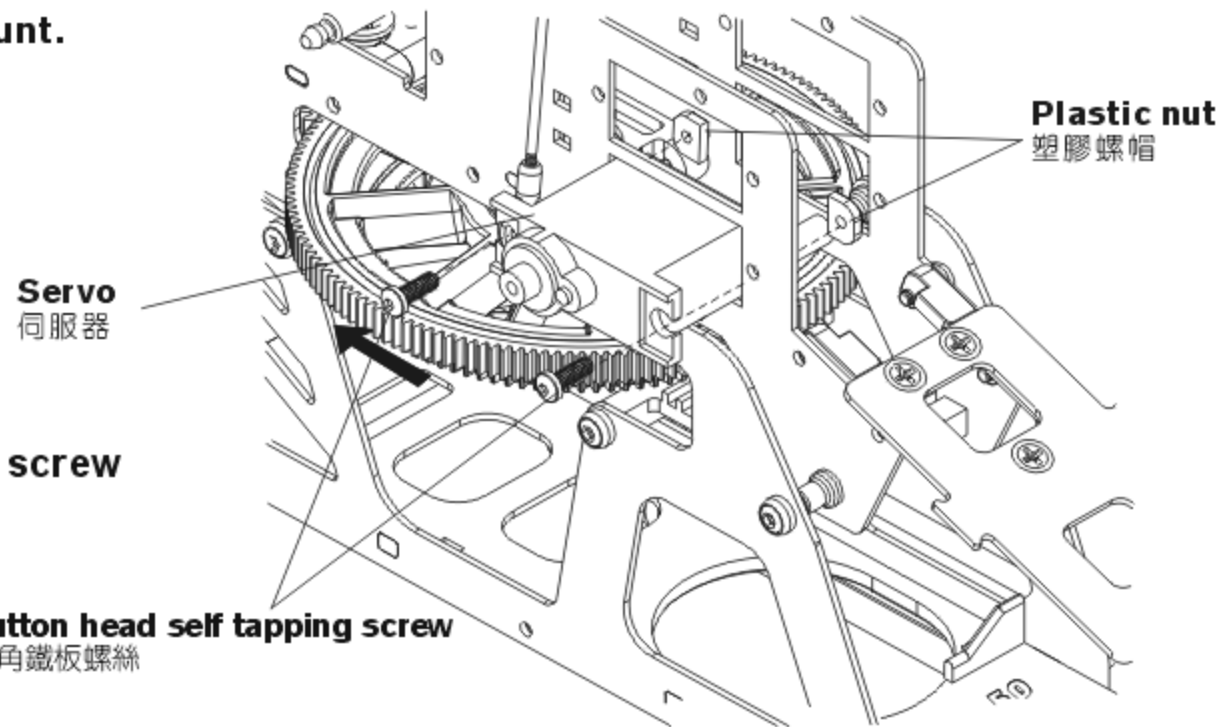

4. Use T2x8 Socket button head self-tapping screw and nuts to fix the servo from two sides.

以零件包所附的T2x8半圓頭內六角鐵板螺絲與塑膠螺帽, 將伺服器的兩側鎖附固定

Socket button head self tapping screw
半圓頭內六角鐵板螺絲
T2X8mm

5. Next, install the second servo inside the upper mount. Note the output shaft must be oriented toward the rear of the helicopter. Then use the screws to fix.

接下來, 將第二顆伺服器安裝於上方的固定座, 伺服器齒輪軸須偏向直昇機の後方, 再以螺絲將伺服器鎖附固定。

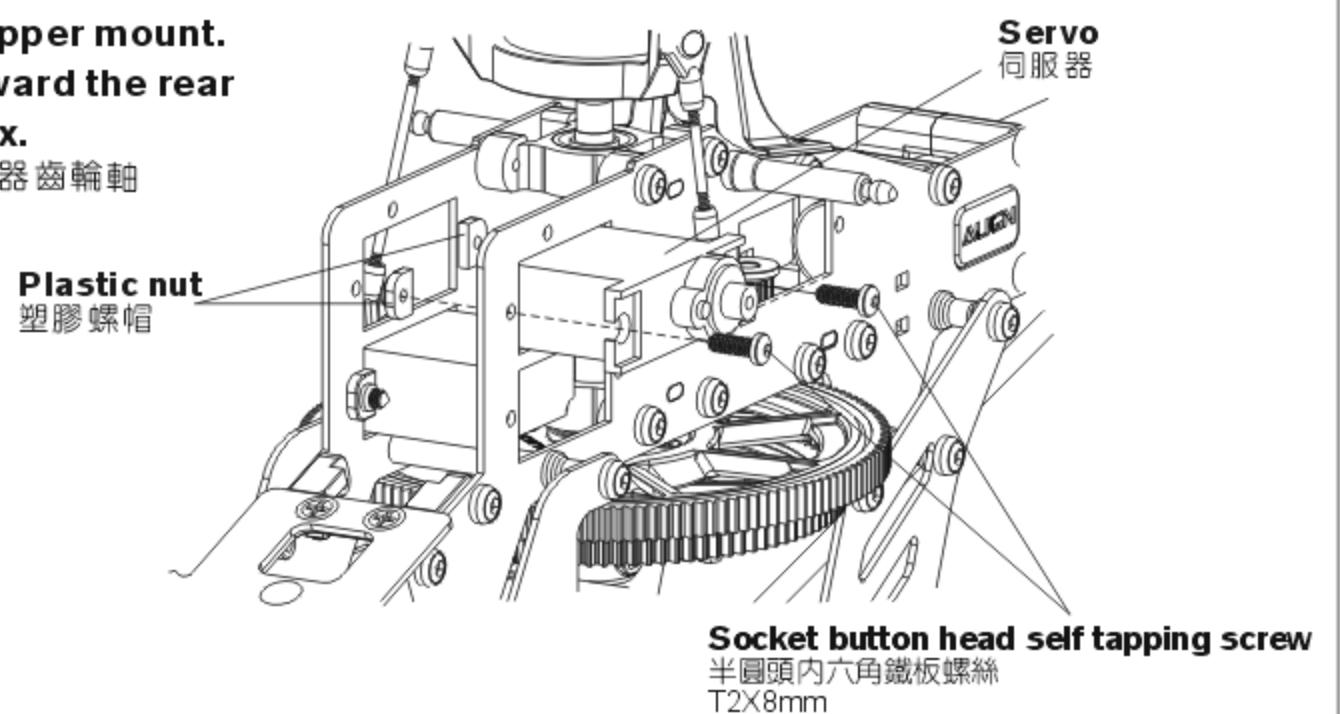

Plastic nut
塑膠螺帽

Socket button head self tapping screw
半圓頭內六角鐵板螺絲
T2X8mm

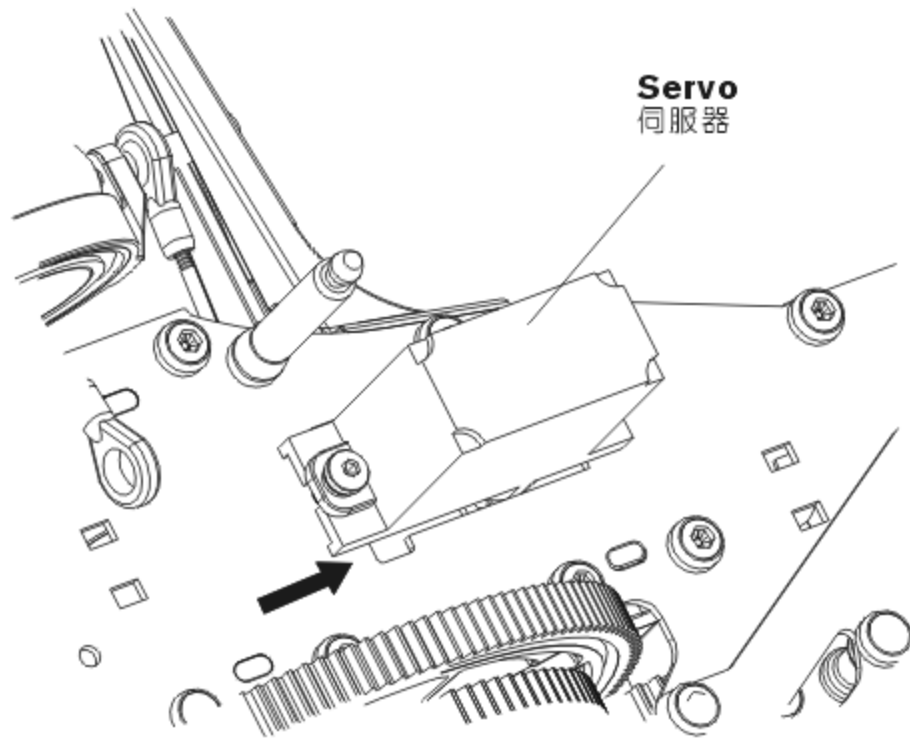

6. See the picture, install the third servo outside the rear mount of the main frame (L) or (R). The servo is installed outside of the frame and the output shaft must be oriented toward the rear of the helicopter, set the signal wire in the retained space to avoid any scrape. Then use the screws and nuts to fix.

如圖示,第三顆伺服器安裝在左側板(或右側板)後方的固定座,伺服器本體外露機身,伺服器齒輪軸偏向直昇機後方,訊號線可置於預留的小孔避免刮傷,再以螺絲及螺帽將伺服器鎖附固定。

7. Set the signal wire next to the main frame inside and use a strap to secure it for avoiding scraping the wire and interfering the flight. Finally, set the servo neutral and then reinstall the servo horn.

將伺服器的訊號線貼近側板內側,並以束線帶加以固定,以免訊號線刮傷或干涉直昇機動作。最後待伺服器中立點調整後,再將拆下的伺服舵片裝回。

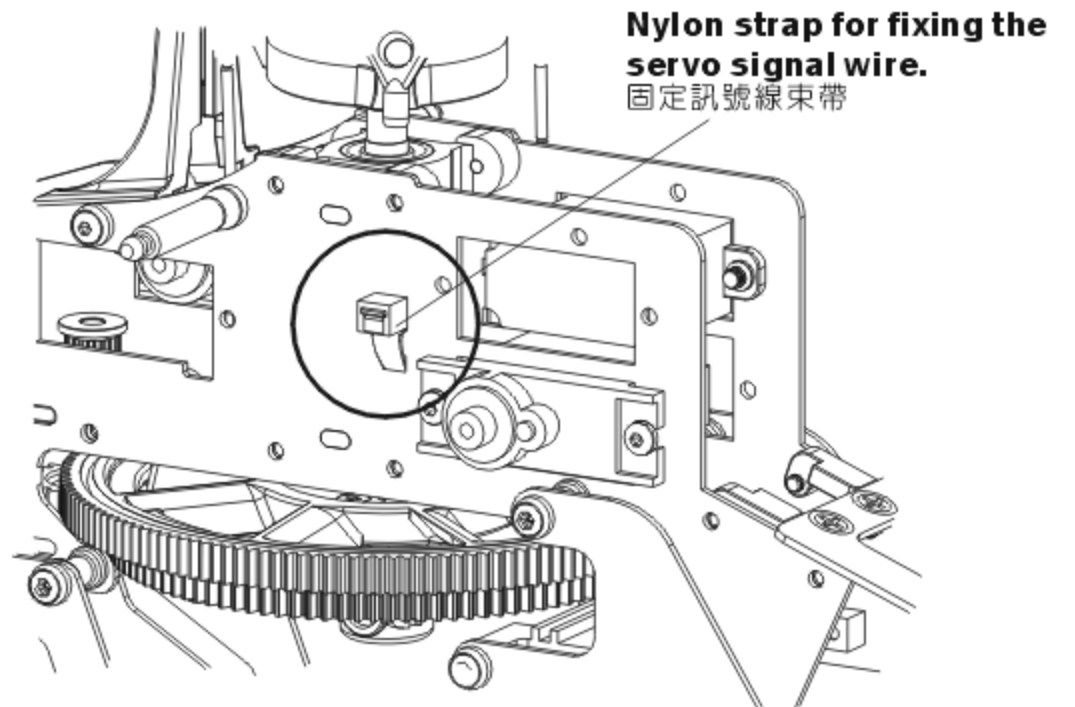

8. Install the tail rudder servo on the tail servo mount. Set the servo horn and linkage rod at right angle (90 degrees).

依圖示的方向將尾舵伺服器鎖附於固定座上,注意舵片與連桿須呈90度。

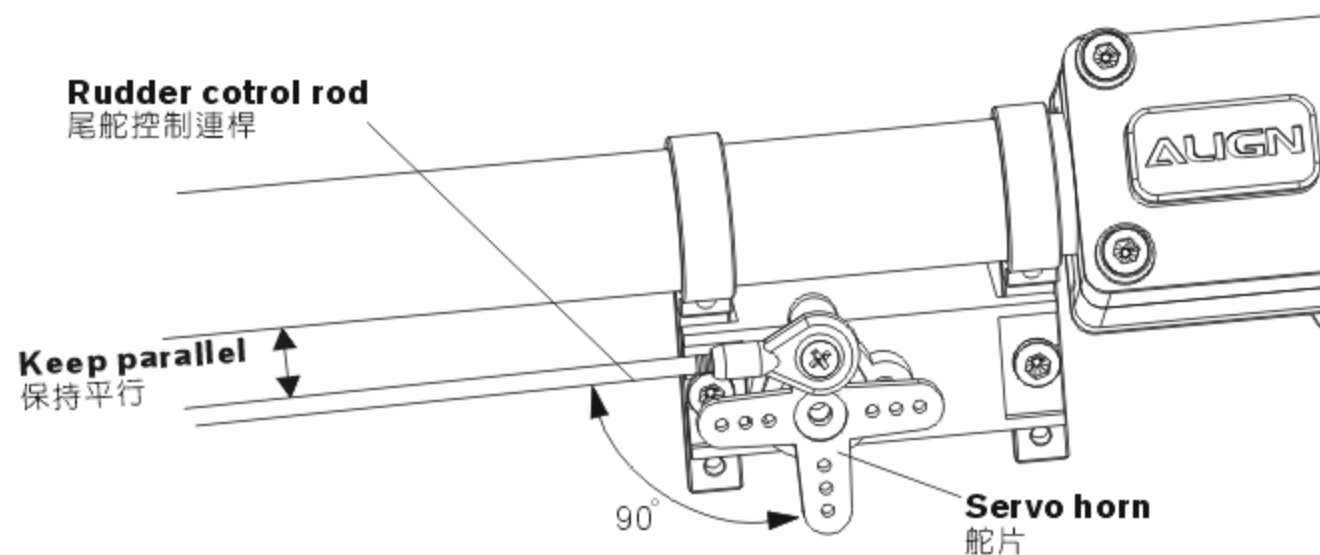

9. Install the rudder control rod to the linkage ball of tail rotor control arm.

尾舵控制連桿的另一端則壓入尾旋翼控制臂的球頭上。

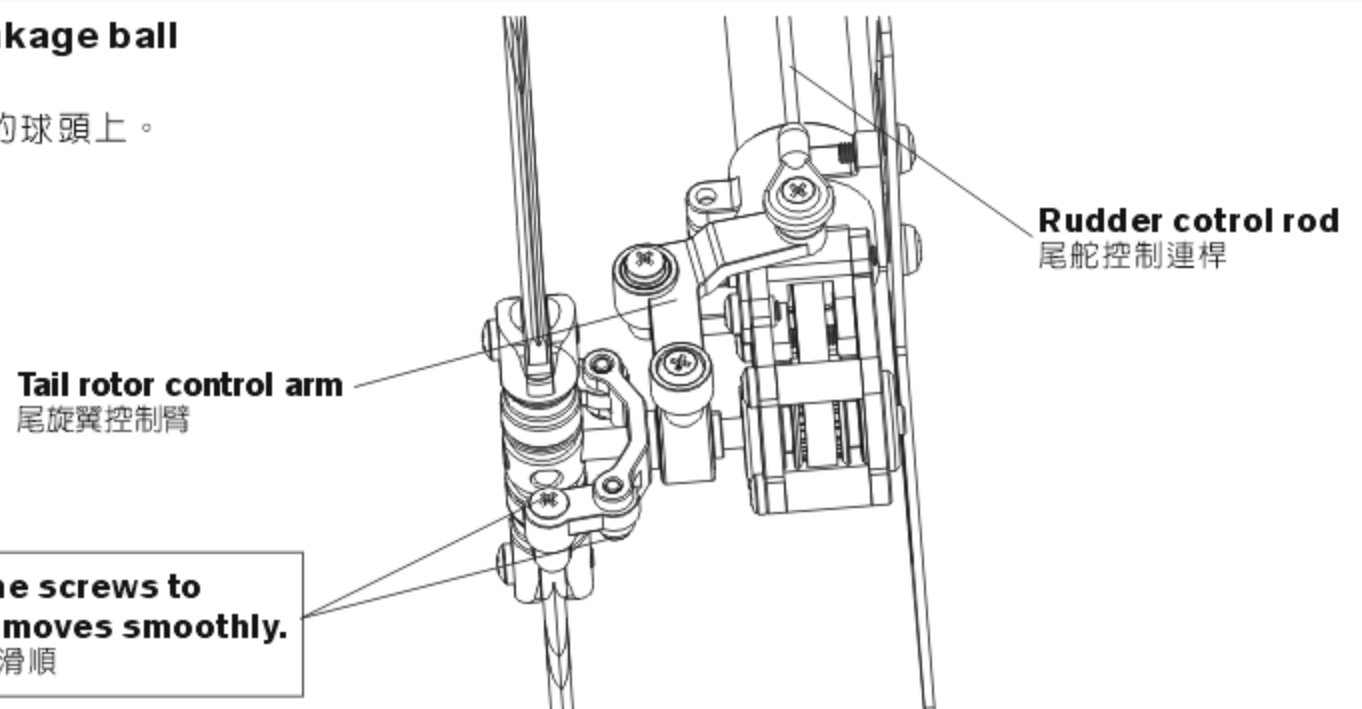

Please note over tighten the screws to make sure the control arm moves smoothly.
尾旋螺絲請勿過緊以確保控制臂滑順

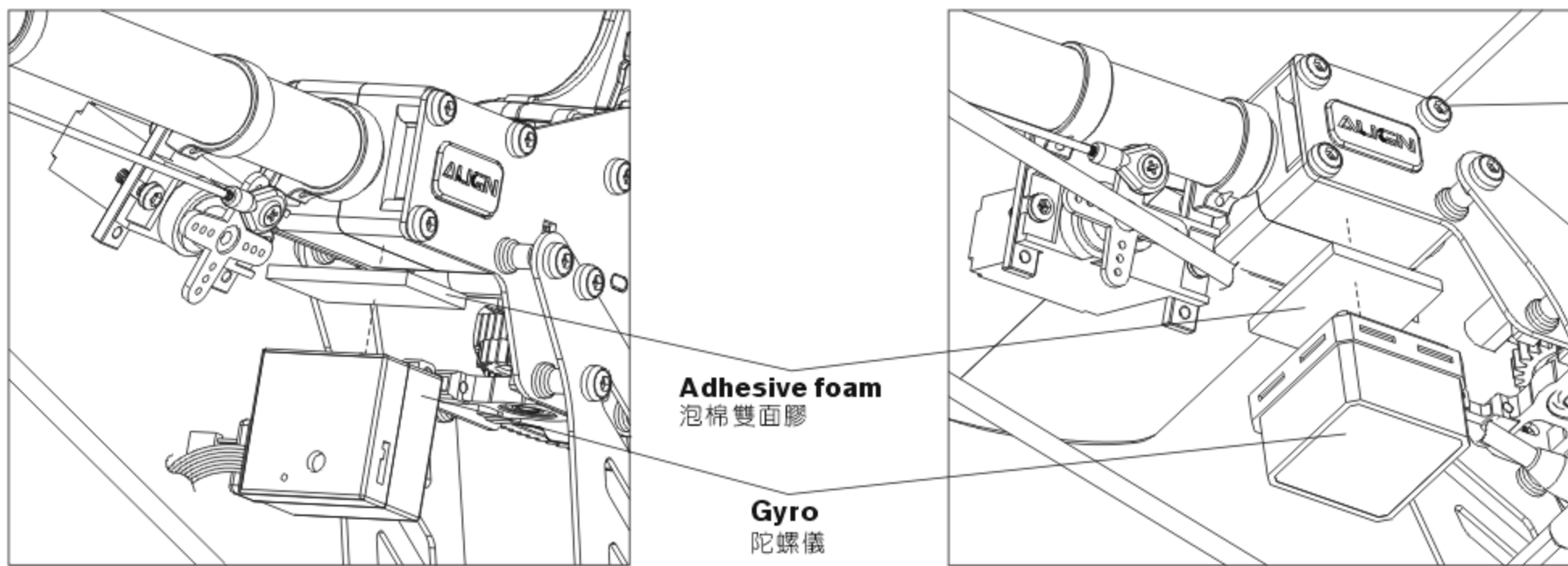

First clean the mounting surface and the bottom surface of the gyro. Then use a adhesive foam to secure the gyro on the top of the tail boom mount.

先將陀螺儀與尾管固定座的貼合面擦拭乾淨,再使用泡棉雙面膠確實將陀螺儀固定。

Battery mounting and fixing 電池安裝與固定

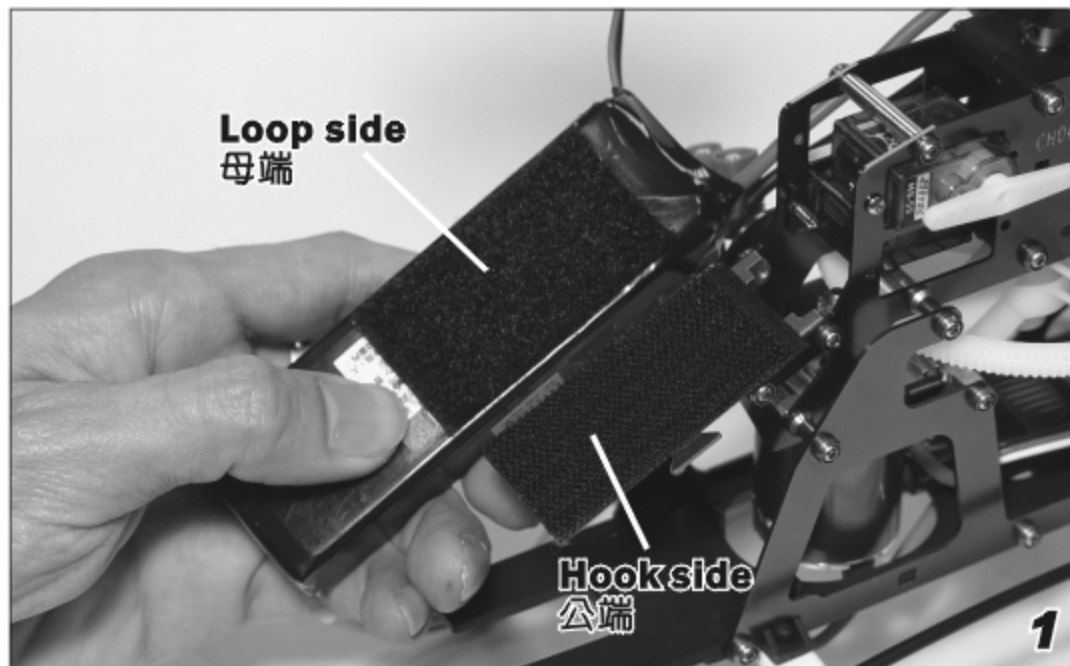

Use Hook and Loop Tape, tape the Hook side (hooked) on the battery mounting plate and the Loop side (fuzzy) on the battery (see illustration) to fix the battery and avoid any slip.

以附贈的魔術沾膠帶,將公端的魔術沾(勾狀)粘貼於電池座上,母端的魔術沾(纖毛狀)黏貼於電池上(如照片所示),可有效的固定電池,避免滑動。

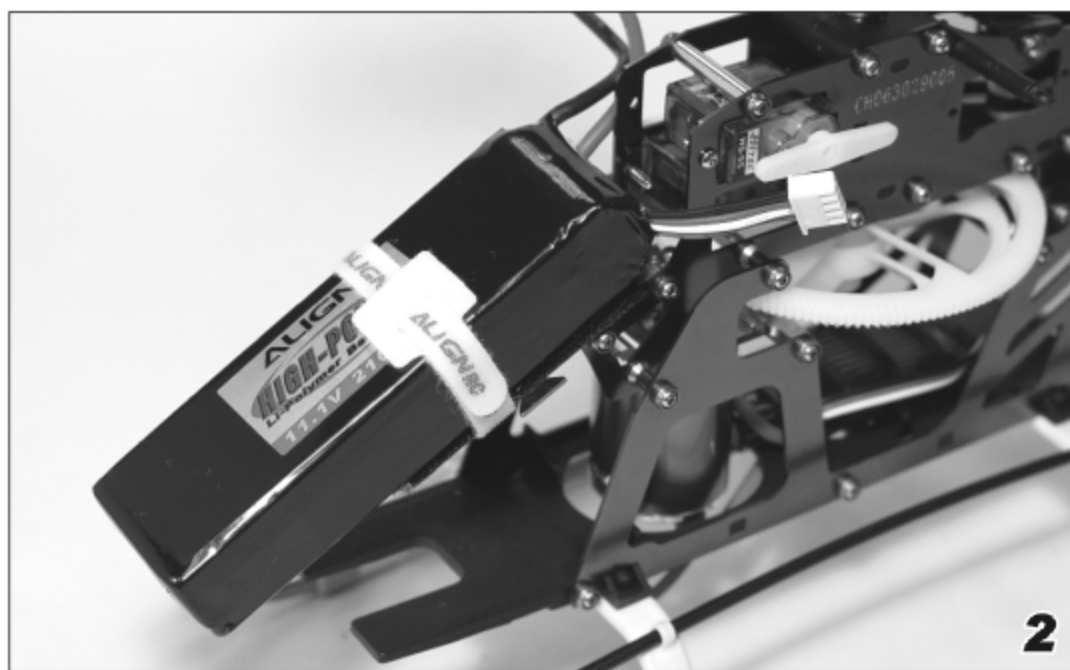

Adjust the battery position forward or backward to set the center of gravity until the model holds a level position when levelly lift up the main rotor blades to make the model in the air. After checking the center of gravity, use a hook and loop fastening tape to secure the battery.

移動電池的前後來調整直昇機的重心,直到水平提取主旋翼使機身懸空時,機身也呈水平狀態,重心確認後,以所附的魔術帶將電池束緊固定。

Motor and ESC connection 馬達與調速器的連接

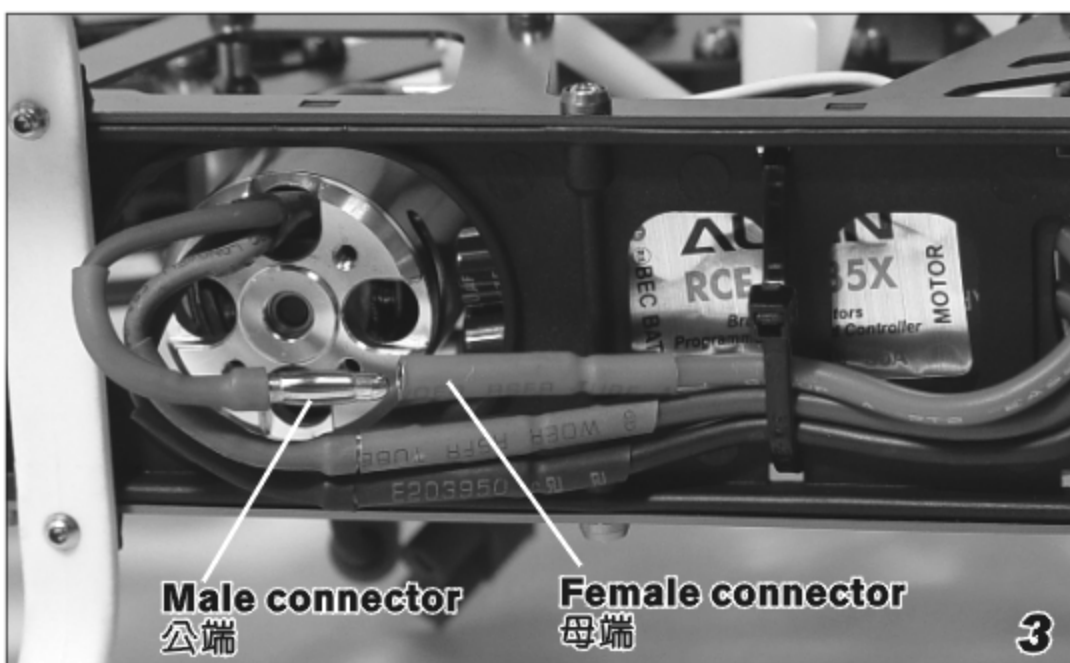

Follow the illustration to install the ESC and use a strap to secure it. Please solder the three wires of motor by 3.0mm male gilt connectors; solder the wires of ESC by the female gilt connectors. After soldering, put on the heat shrink tubes according to the colors and heat the tubes to shrink. Finally, insert the gilt connectors of motor and ESC according to the colors.

調速器可依照左圖建議的位置安裝,並以束線帶固定,馬達端的三條出口線請以公端3.0mm 鍍金接頭焊接,調速器則焊上母端,完成後依相同的顏色套上熱縮套管加熱收縮,最後依相同的顏色將馬達與調速器的鍍金接頭插入。

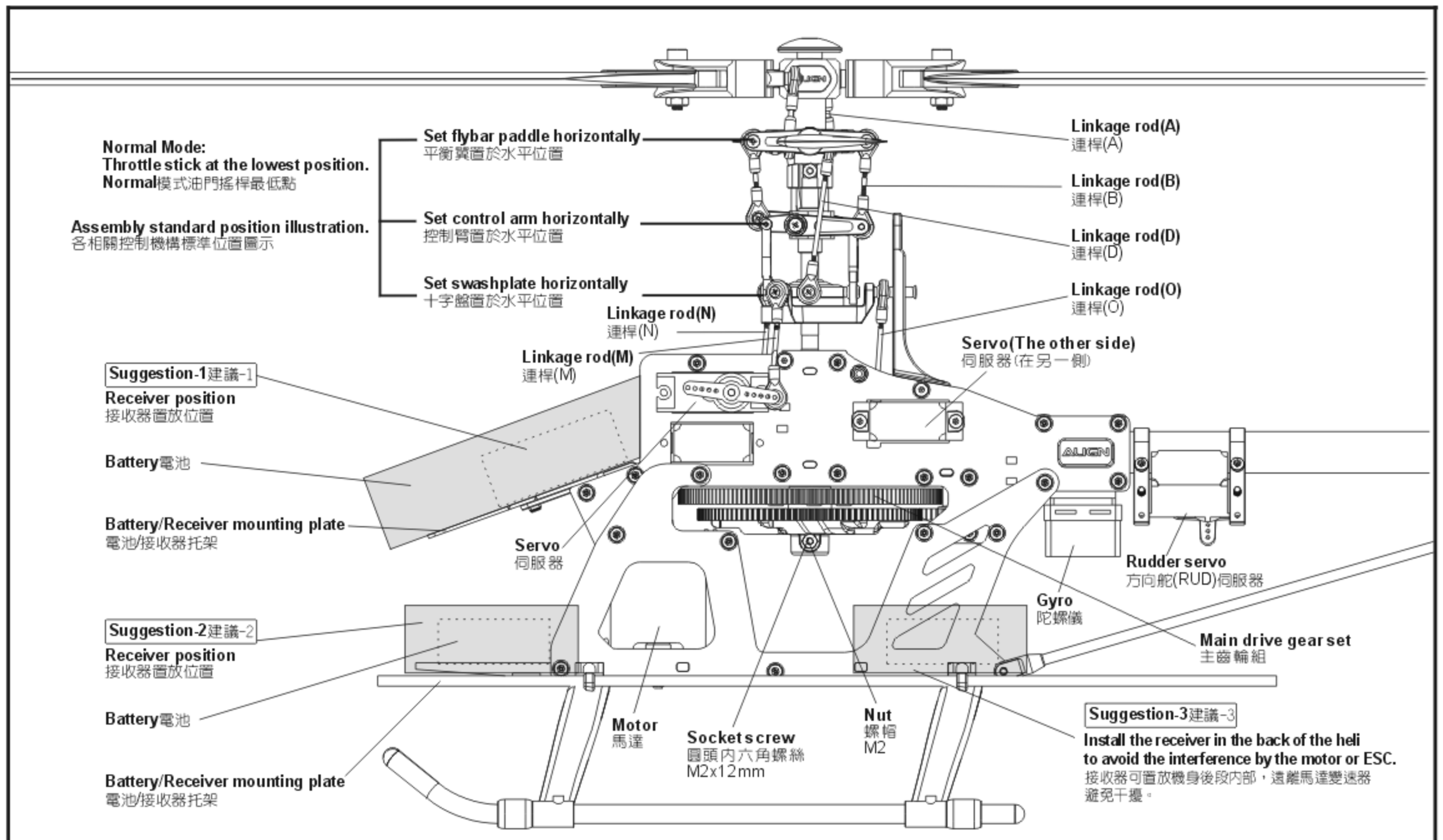

8.MAIN ROTOR ADJUSTMENTS 主旋翼平衡與雙槳校正

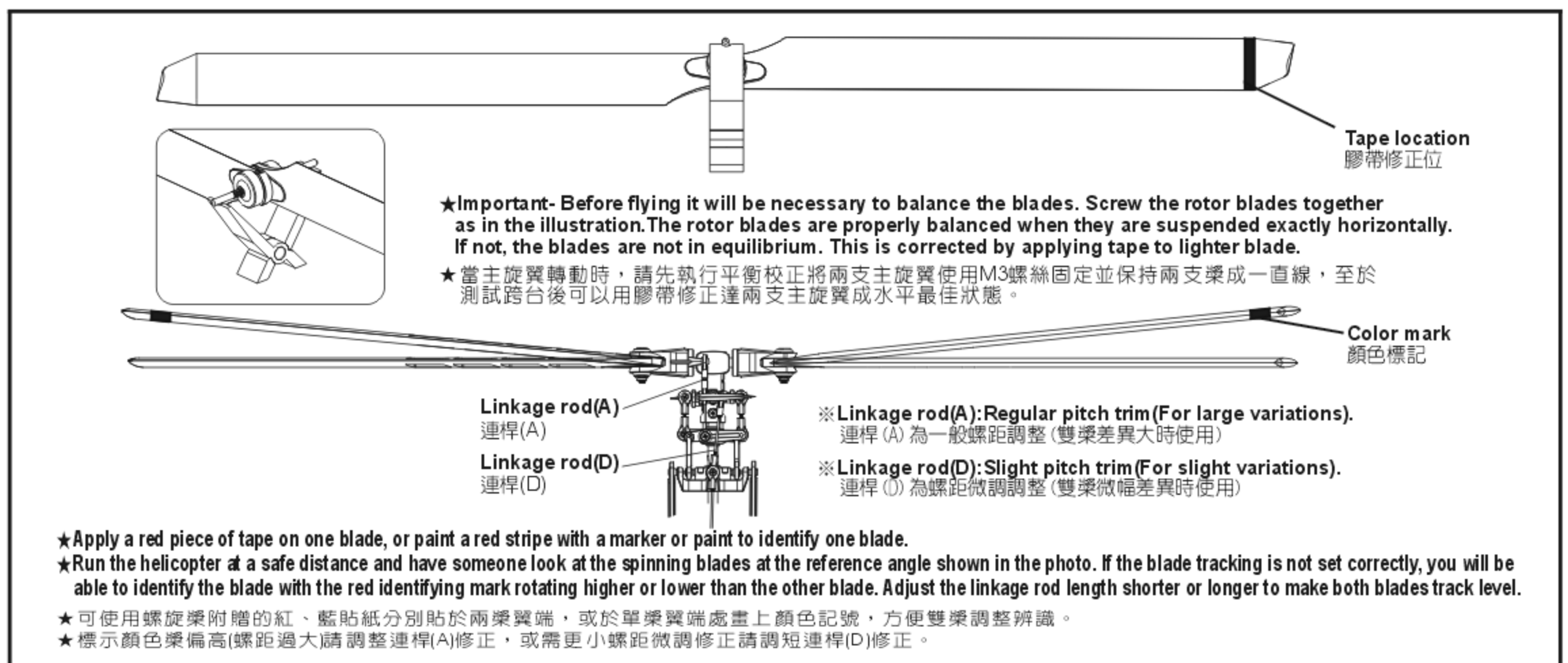

9.TROUBLESHOOTING THE POWER SYSTEM 動力異常檢查

Please check the followings when the power or speed gets abnormally slow:

1. Check the battery is the correct specification for the helicopter and is fully charged.
2. Check if the pitch setting is too high. (If the pitch setting is too high, it will affect the power efficiency and flight time.)
3. Check the tightness of the main rotor blades. Blades should be tightened so that they do not move freely, but can be moved by applying slight pressure by hand.
4. Check for vibration on the main and tail rotors (vibration can be caused by main shaft/feathering shaft wear, damage, or loosens, check all linkages and bearings for excess play or wear).
5. Check for interference caused by improper gear mesh or belt tension.

您的標準動力配置如有發現動力效能與速度明顯降低時!可注意下列幾點因素:

1. 電池規格效能與電力是否足夠!
2. Pitch是否過大!(過大pitch設定，將明顯影響動力效能與飛行時間)
3. 主旋翼是否有雙槳!
4. 主旋翼與尾旋翼是否明顯震動!(主軸、主/橫軸變型與鬆動所產生震動※必要時請更新或上膠固定)
5. 各傳動齒或傳動軸是否太緊的干涉!(特別注意!馬達主齒與主齒輪需有適當間隙)
6. 皮帶是否太鬆而震動或太緊的干涉!

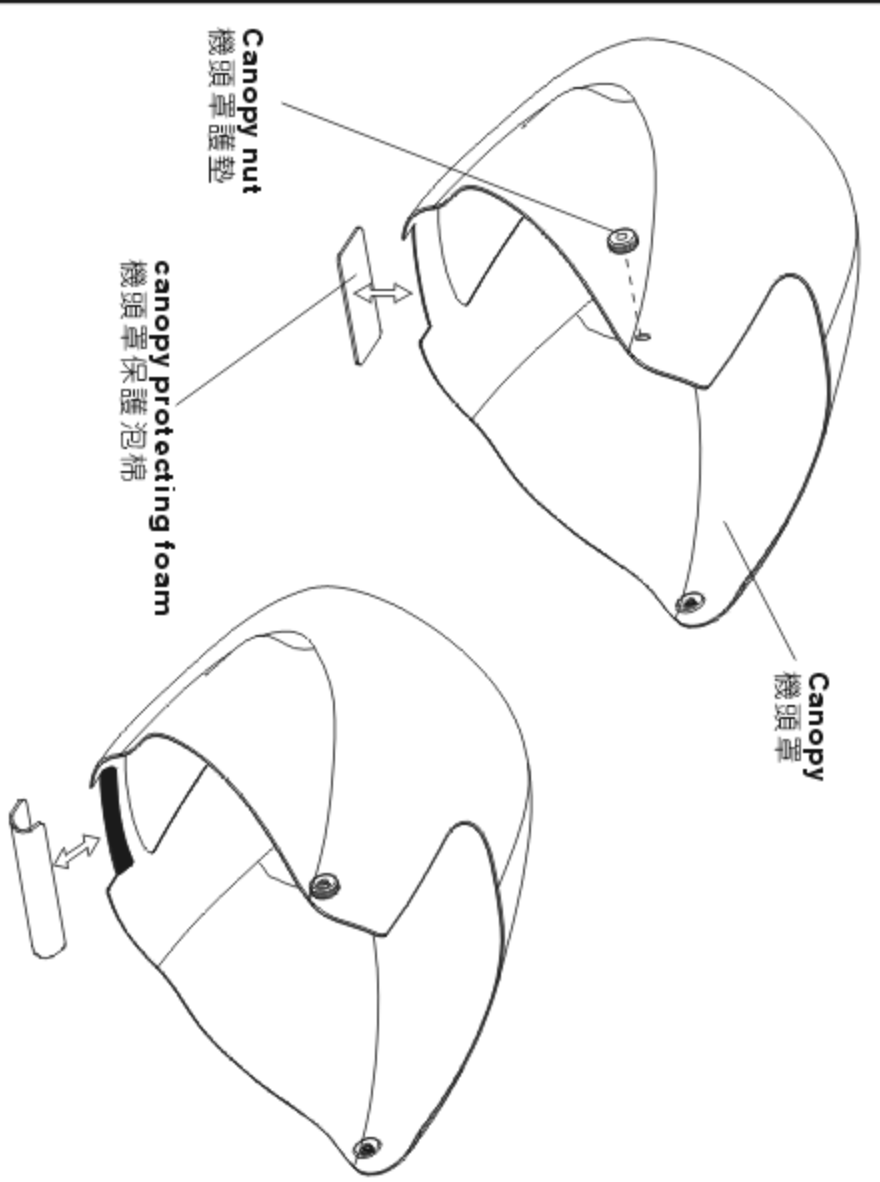
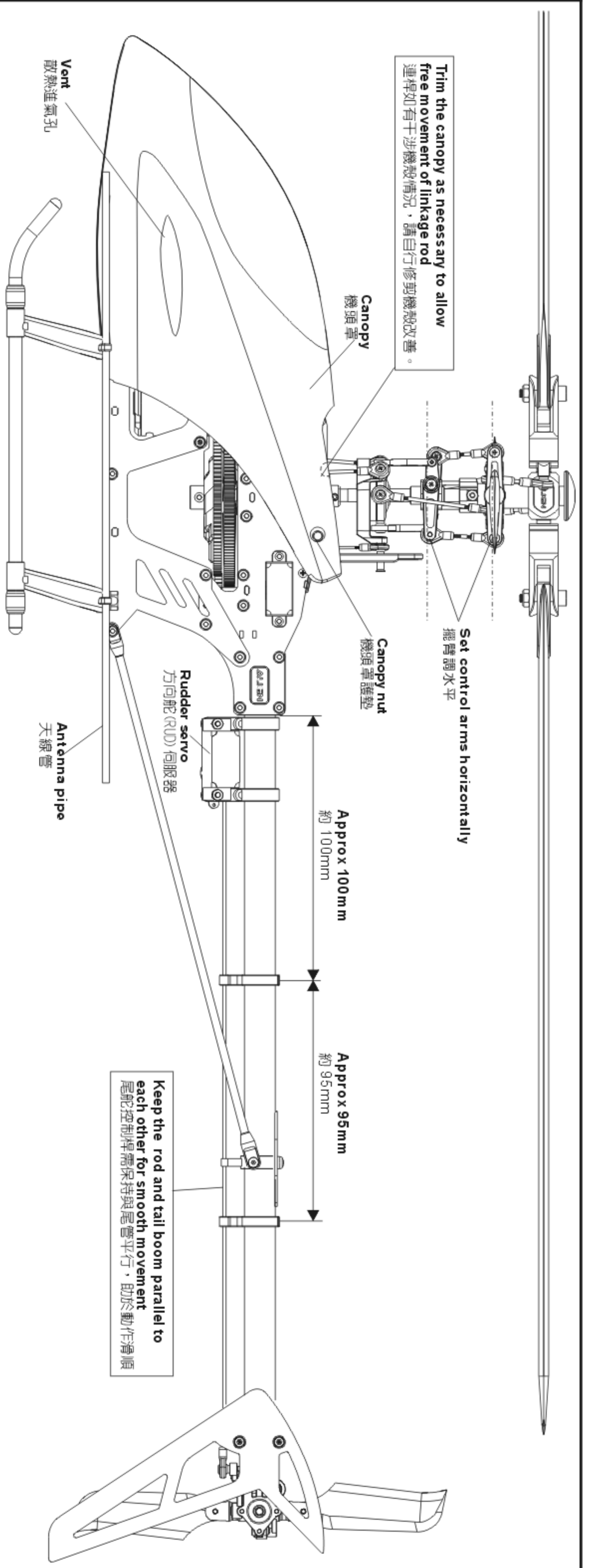

First clean the taping surface of canopy, and then tape a canopy protecting foam on as illustration. 先將機頭罩貼合面擦拭乾淨，再使用機頭罩保護泡棉貼附於上圖所示

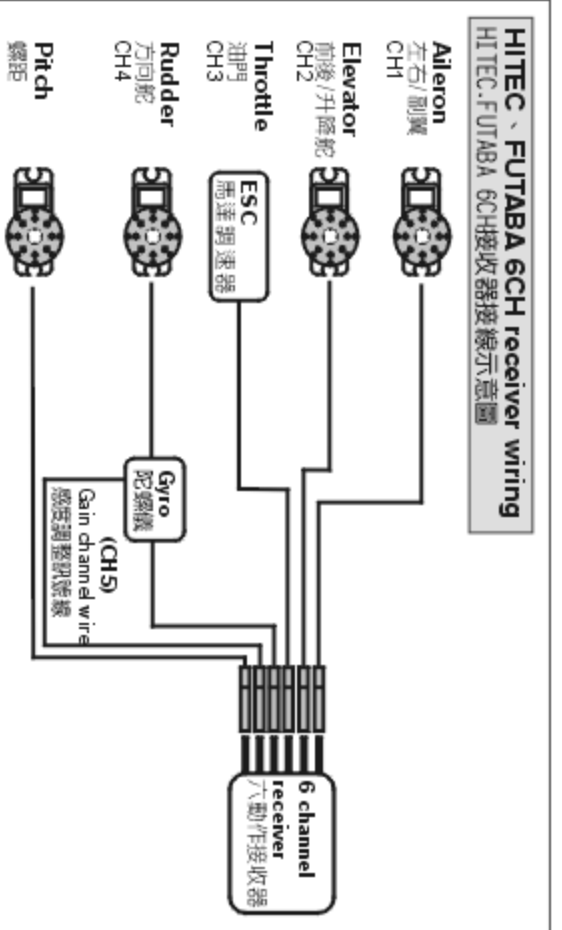

6-Channel Receiver is adequate for the requirements of the T-REX heli. You will need the following channels at a minimum: Throttle, Rudder, Elevator, Aileron, and especially Pitch(CH6) and Gyro(CH5) controls. 六動作的接收器已足夠應對T-REX遙控直升機的各項需求，除了油門、方向舵、升降舵、副翼等基本動作外，亦可以對應具備感度調整訊號線的陀螺儀(CH5)與螺距(CH6)。

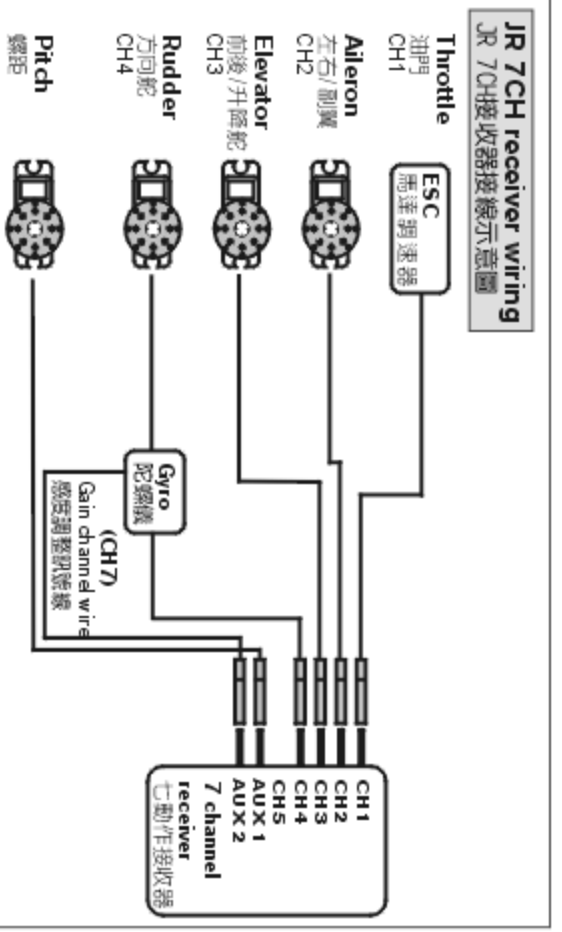

7-Channel Receiver is adequate for the requirements of the T-REX heli. You will need the following channels at a minimum: Throttle, Rudder, Elevator, Aileron, and especially Pitch(AUX 1) and Gyro(AUX 2) controls. 七動作的接收器已足夠應對T-REX遙控直升機的各項需求，除了油門、方向舵、升降舵、副翼等基本動作外，亦可以對應具備感度調整訊號線的陀螺儀(AUX 2)與螺距(AUX 1)。

To set this option is to turn on the transmitter and connect to the helicopter power. Note: For the safety, please do not connect ESC to the brushless motor before the setting to avoid the motor running and cause the accident during the setting.

此項設定只要開啓發射器，接上直昇機電源即可進行操作。注意：為了安全起見，設定前請先不要將無刷調速器與無刷馬達的三條線接上，以免調整時啓動馬達而發生危險。

JR Transmitter/Servo
JR遙控器對應伺服器關係

If any interference caused by rod(N) and outer covering, please install the ball links inside.
若連桿(前)端之連桿頭與機殼會碰觸，則請連桿頭裝置於內側。

Please note to set the subtrim neutral for the first trial flight. If the helicopter wags, please trim linkage rod(M) (N). Trim both rods simultaneously to adjust for forward/backward tilt. Trim rod(M) or (N) for right/left tilt.
首航飛行測試，注意遙控器機調均設定中立點，若發現飛行時，機身前後左右偏移，請先調整連桿(M) (N) 前後偏移：連桿(M) (N) 同步調整；左右偏移：連桿(M) (N) 單獨調整為標準。

Positions of CH2、CH6 are exchangeable, After assembling as photo (Note: Set the transmitter under CCPM 120 degrees mode), pull throttle stick (pitch) upward. If one swashplate servo (or two servos) moves downward, adjust reverse switch (REV) on the transmitter to make it moves upward. If three servo move downward, adjust the travel value (+-) of SWASH CH6 on the transmitter to make them move upward. When the actions of Aileron and Elevator are opposite, adjust travel values of SWASH CH2 and CH3.

CH2、CH6可互換配置，依圖連結後(注意：遙控器須設定於CCPM 120°十字盤模式)，將油門搖桿(Pitch)往上推，若十字盤伺服器有1個或2個往下移時，請調整遙控器的反轉開關(REV)使伺服器往上，若3個伺服器同時往下移時，請調整遙控器 SWASH CH6 行程量的正負值，使伺服器同時往上移，副翼與前後動作相反時，同樣調整 SWASH CH2、CH3 行程量正負值。

FUTABA/HITEC Transmitter/Servo
FUTABA/HITEC遙控器對應伺服器關係

Positions of CH1、CH6 are exchangeable, After assembling as photo (Note: Set the transmitter under CCPM 120 degrees mode), pull throttle stick (pitch) upward. If one swashplate servo (or two servos) moves downward, adjust reverse switch (REV) on the transmitter to make it moves upward. If three servo move downward, adjust the travel value (+-) of SWASH CH6 on the transmitter to make them move upward. When the actions of Aileron and Elevator are opposite, adjust travel values of SWASH CH1 and CH2.

CH1、CH6可互換配置，依圖連結後(注意：遙控器須設定於CCPM 120°十字盤模式)，將油門搖桿(Pitch)往上推，若十字盤伺服器有1個或2個往下移時，請調整遙控器的反轉開關(REV)使伺服器往上，若3個伺服器同時往下移時，請調整遙控器 SWASH CH6 行程量的正負值，使伺服器同時往上移，副翼與前後動作相反時，同樣調整 SWASH CH1、CH2 行程量正負值。

Recommend to choose Head Lock type for Gyro and turn off Revolution mixing(RVMX) mode on the transmitter, then set the gain switch on the transmitter and the gyro to Head lock mode. The gain setting is about 70%, and after transmitter setting, connect to the helicopter power for working on tail neutral setting. Note: When connecting to the helicopter power, please do not touch tail rudder stick and the helicopter. Then wait for 3 seconds, make tail servo horn and tail servo at a right angle(90 degrees), tail pitch assembly must be correctly fixed about in the middle of the travel of tail rotor shaft for standard neutral setting.

陀螺儀選擇，建議選用鎖定式陀螺儀，且發射器內陀螺儀設定請關閉根軸混控模式，並將發射器上的感度開關與陀螺儀切至鎖定模式，感度設約 70% 左右，發射器設定完成後接上直昇機電源，即可進行尾中立點設定。注意：當接上直昇機電源時請勿撥動尾舵搖桿或碰觸機體，待3秒陀螺儀鎖定後尾伺服器需與尾尾翼約成 90°，尾旋翼控制組須正確置於尾橫軸行程約中間位置，即為標準尾中立點設定。

TAIL NEUTRAL SETTING 尾中立點設定

After setting Head Lock mode, correct setting position of tail servo and tail pitch assembly is as photo. If the tail pitch assembly is not in the middle position, please adjust the length of rudder control rod to trim.
陀螺儀鎖定後尾伺服器與尾 Pitch 控制組正確擺置位置。若尾 Pitch 控制組未置中時請調整尾控制連桿的長度來修正。

HEAD LOCK DIRECTION SETTING OF GYRO 陀螺儀鎖定方向設定

To check the head lock direction of gyro is to move the tail counterclockwise and the tail servo horn will be trimmed clockwise. If it trims in the reverse direction, please switch the gyro to "REVERSE".
陀螺儀鎖定方向確認，當手搖尾部反時鐘擺動，尾伺服器應順時鐘修正，反向時請切換陀螺儀上"鎖定反向"開關修正。

GENERAL FLIGHT 一般飛行模式

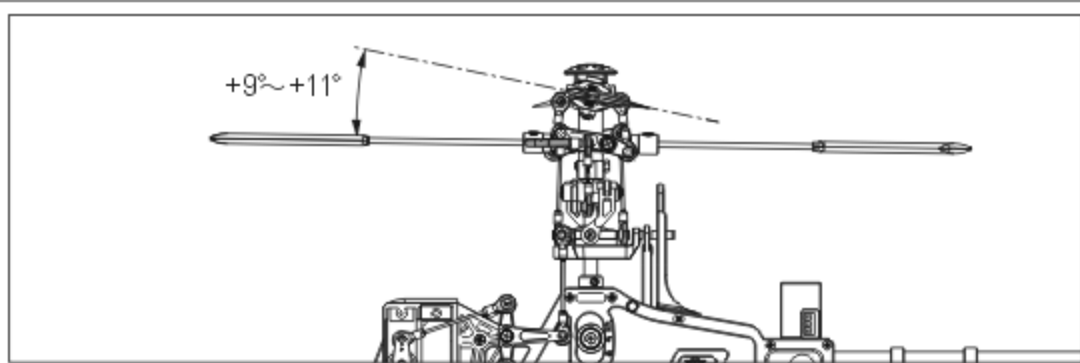

Stick position at high/Throttle 100%/Pitch +9° ~ +11°
搖桿高速/油門100%/Pitch +9° ~ +11°

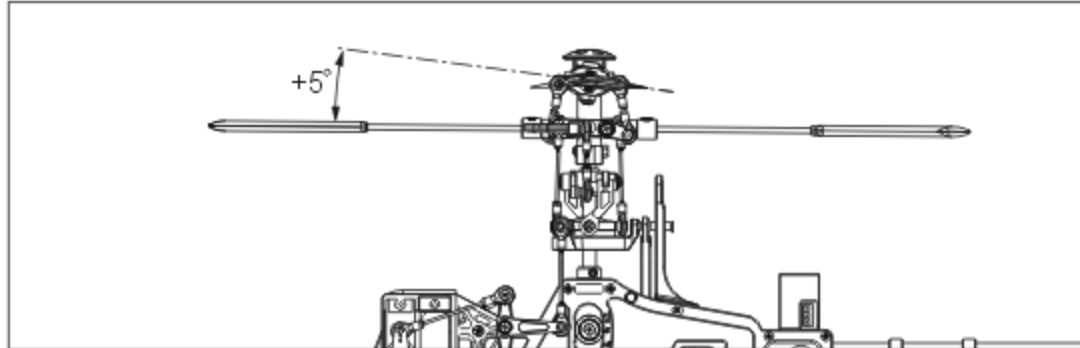

Stick position at Hovering/Throttle 65%~70%/Pitch +5°~+6°
搖桿停懸/油門65%~70%/Pitch +5°~+6°

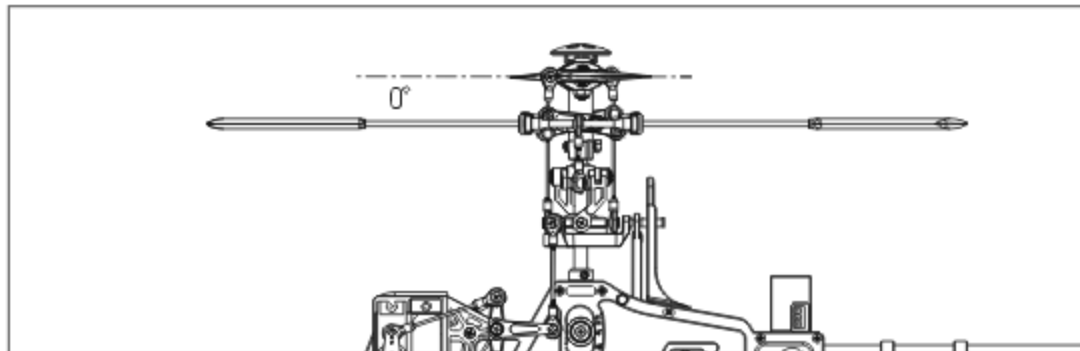

Stick position at low/Throttle 0%/Pitch 0°
搖桿低速/油門0%/Pitch 0°

GENERAL FLIGHT 一般飛行模式

	Throttle 油門	Pitch 螺距
5	100% High speed 100% 高速	+9° ~ +11°
4	85%	
3	65%~70% Hovering 65%~70% 停懸	+5°
2	40%	
1	0% Low speed 0% 低速	0°

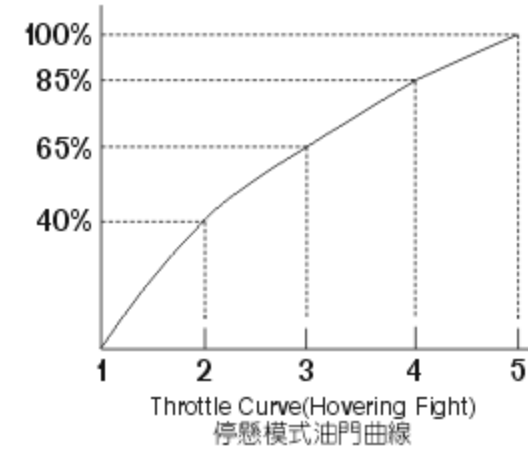

Pitch and Rotation Speed Pitch與轉速關係

TIP: It is recommended to use a lower pitch setting when using higher RPM Head speed. This will allow for better power.

搭配要領: 如果使用較高轉速馬達動力建議搭配調低 Pitch, 將獲得較佳動力效能。

3D FLIGHT 3D特技飛行模式

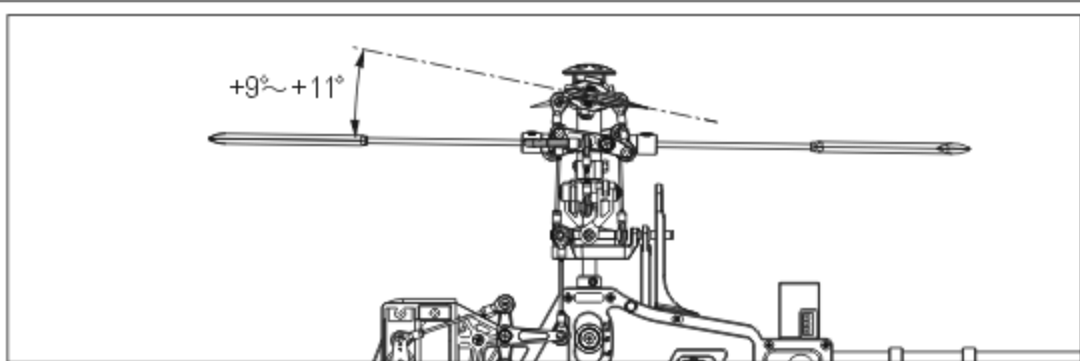

Stick position at high/Throttle 100%/Pitch +9° ~ +11°
搖桿高速/油門100%/Pitch +9° ~ +11°

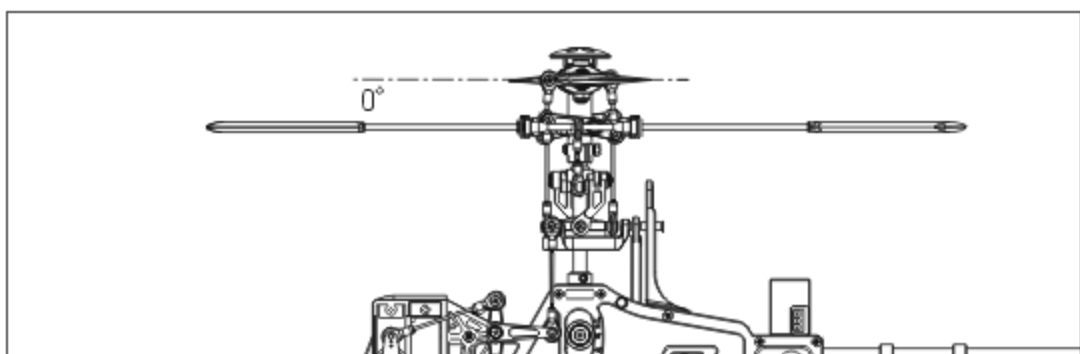

Stick position at middle/Throttle 90%/Pitch 0°
搖桿中速/油門90%/Pitch 0°

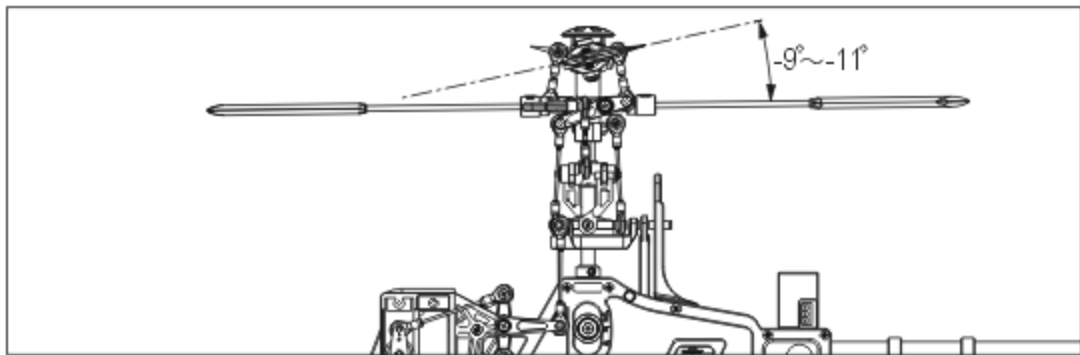

Stick position at low/Throttle 100%/Pitch -8° ~ -10°
搖桿低速/油門100%/Pitch -8° ~ -10°

IDLE 1: SPORT FLIGHT

	Throttle 油門	Pitch 螺距
5	100%	+9° ~ +11°
4	85%	
3	80%	+5°
2	85%	
1	90%	-5°

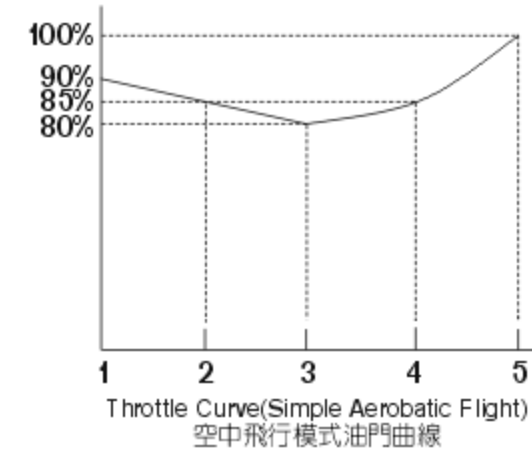

IDLE 2: 3D FLIGHT

	Throttle 油門	Pitch 螺距
5	100% High 100% 高	+9° ~ +11°
3	90% Middle 90% 中	0°
1	100% Low 100% 低	-9° ~ -11°

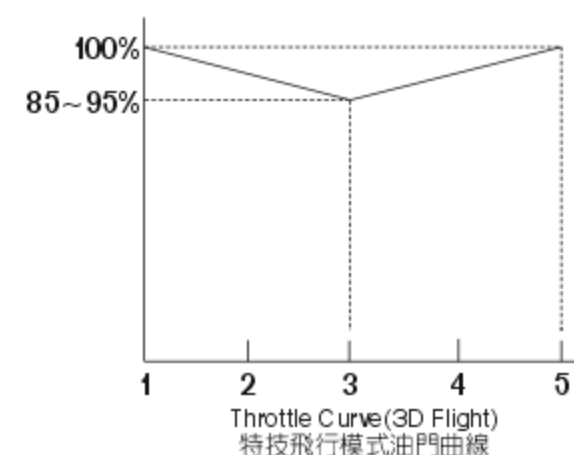

1. Pitch range: Approx. 25 degrees.
2. If the pitch is set too high, it will result in shorter flight duration and poor motor performance.
3. Setting the throttle to provide a higher speed is preferable to increasing the pitch too high.



1. 螺距 (Pitch) 總行程約 25°
2. 過大螺距設定, 會導致動力與飛行時間降低。
3. 動力提昇以較高轉速的設定方式, 優於螺距調大的設定。

Battery 電池: ALIGN Li-Poly 11.1V 2100mAh

Motor Gear 馬達主齒	Main Rotor Blade 主旋翼規格	PITCH 螺距		Current(A) approx. 電流(A) 大約值	Throttle Curve 油門曲線	RPM approx. 主旋翼轉速 大約值
12T	325mm PRO Blade PRO 主旋翼	Hover 停懸	+5°	7.9	0/50/70/85/100%	2160
		Idle 2	0°	9.9	100/100/100/100/100%	2980
			±9°	23.0		2390
13T	325mm PRO Blade PRO 主旋翼	Hover 停懸	+5°	8.1	0/50/65/85/100%	2170
		Idle 2	0°	11.7	100/100/100/100/100%	3160
			±9°	25.0		2450
12T	325mm Blade 主旋翼	Hover 停懸	+5°	7.8	0/50/65/85/100%	2150
		Idle 2	0°	10.6	100/100/100/100/100%	3000
			±9°	25.1		2390
13T	325mm Blade 主旋翼	Hover 停懸	+5°	8.2	0/50/60/85/100%	2170
		Idle 2	0°	12.8	100/100/100/100/100%	3130
			±9°	26.6		2450

Note: Please use the pitch gauge to adjust the pitch value. Incorrect pitch setting may affect the helicopter performance and reduce ESC's life and battery's life.

註: 請務必使用螺距規來量測調整螺距, 不正確的設定不但無法發揮直昇機的特性, 更會影響到無刷調速器與電池的壽命。

15.POWER SYSTEM RECOMMENDATION FOR STANDARD EQUIPMENT 原裝動力搭配建議

Align RCM-BL430X 3550KV high efficiency brushless motor

When hovering, general, 3D flights, recommend to use motor gear 12T, rotor blade 315 or 325mm, and Max. Pitch +9° ~ +10° for beginner/intermediate pilot.

For hand 3D flight, recommend to use motor gear 13T, rotor blade 315 or 325mm and Pitch setting at ±9°

亞拓RCM-BL430X 3550KV高效率無刷馬達

初中階者飛行停懸、空中、3D飛行模式, 建議搭配12T馬達主齒, 使用315、325槳最大Pitch+9° ~ +10°

暴力3D飛行模式建議搭配13T馬達主齒, 使用315、325槳Pitch設 ±9°

16.RCE-BL35X ESC Setting suggestion 無刷調速器程式設定建議:

⊙ **Brake Option: When flying helicopters, select "Brake disable(1-1)".**

第一項制動設定: 使用於直昇機時務必設定在(1-1) "無制動" 模式。

⊙ **Timing Option: When using 6 pole or more brushless motor, select "Mid-timing(2-2) to get better efficiency.**

If select "High-timing(2-3) to increase power, it will increase current and cause power consumption.

第二項進角設定: 搭配六極以上無刷馬達時, 請設定於(2-2) "中進角", 以獲得較佳的效率; 若設定為高進角雖可提升動力輸出, 但會因電流提高而較為耗電。

⊙ **Battery Protection Option: Will cause the motor to pulse, this notifies pilots of low voltage in battery.**

For 3D flight, recommend to select "Middle cutoff voltage protection (3-2)" to avoid low voltage to prematurely damage the battery; For beginner to practice hovering or do a general flight, recommend to select "High cutoff voltage protection (3-1)". To avoid the low voltage caused by battery over-discharging.

第三項電池截止電壓保護設定: 3D飛行模式建議設定在(3-2) "中截止電壓" 保護, 以避免特技飛行時因電流較高, 產生較大的壓降而提早啟動截止電壓保護; 初學者僅作停懸練習或一般飛行模式時請將設定改為(3-1) "高截止電壓保護", 以免對電池過放造成電壓偏低而影響電池壽命。

NOTE: Please use full-charged battery to fly. If the battery is not full-charged, ESC may erroneously set the cut-off voltage and cause the battery over-discharged.

注意: 飛行時務必使用已充飽之電池, 若電池未充飽或電壓過低的電池, 可能會造成電變誤判保護截止電壓, 而有造成電池過放電之可能。

⊙ **Aircraft Option: Default setting is "Helicopter 1 (4-2)" and this option provides Soft Start. You can select "Norma Airplane (4-1)" to cancel this option, or select "Helicopter 2 (4-3)" and this option provides Soft Start and Governor Mode.**

第四項飛機模式: 本變速器初始值已設定為(4-2) "直昇機模式", 具有緩啟動功能, 若欲取消此功能可更改設定為(4-1) "飛機模式" 或(4-3) "直昇機模式2" 具有緩啟動及定速功能。

⊙ **Throttle response speed: Default setting is "Quick throttle response (5-3)", suitable for 3D flight.**

The user can change to the other options according to the demand, "Standard throttle response (5-1)" or "Medium throttle response (5-2)" for soft response speed.

第五項油門反應速度設定: 初始設定為(5-3) "高油門反應速度", 適合3D飛行; 使用者可依需求自行修改設定(5-1) "標準油門反應速度" 或(5-2) "中油門反應速度", 可使油門的反應較為柔和。

PLEASE PRACTICE SIMULATION FLIGHT BEFORE REAL FLYING 飛行前請事先熟練模擬飛行

Do a simulation flight until you familiarize your fingers with the movements of the rudders, and keep practicing until the fingers move naturally.

1. Place the helicopter in a clear open field (Make sure the power OFF) and the tail of helicopter point to yourself.
2. Practice to operate the throttle stick(as below illustration) and repeat practicing "Throttle high/low", "Aileron left/right", "Rudder left/right", and "Elevator up/down".
3. The simulation flight practice is very important, please keep practicing until the fingers move naturally when you hear operation orders being call out.
4. Another safe and effective practice method is to use the transmitter flying on the computer through simulator software sold on the market.

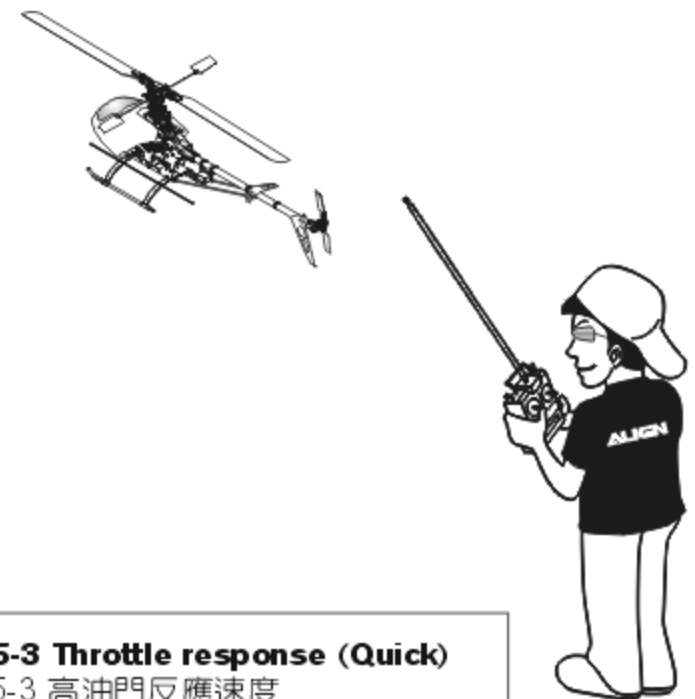

在還沒瞭解直昇機各動作的操控方式前，嚴禁通電飛行，請先進行模擬飛行的練習，並不斷的重複，直到手指可熟練的控制各個動作及方向。

1. 將直昇機放在空曠的地方(確認電源為關閉)，並將直昇機的機尾對準自己。
2. 練習操作遙控器的各搖桿(各動作的操作方式如下圖)，並反覆練習油門高/低、副翼左/右、升降舵前/後及方向舵左/右操作方式。
3. 模擬飛行的練習相當重要，請重複練習直到不需思索，手指能自然隨著喊出的指令移動控制。
4. 另外一種最有效、最安全的練習方式，就是透過市面販售的模擬軟體，以遙控器在電腦上模擬飛行，熟悉各種方向的操控。

ESC setting (RCE-BL35X):

調速器設定建議:

- | | | |
|-------------------------------------|--|---|
| 1-1 Brake Disable
1-1 無煞車 | 3-2 Battery Protection(Middle)
3-2 中電池截止電壓保護 | 5-3 Throttle response (Quick)
5-3 高油門反應速度 |
| 2-2 Mid timing
2-2 中進角 | 4-2 Helicopter 1
4-2 直昇機模式1 | |

Mode 1	Mode 2	Illustration圖示

FLIGHT ADJUSTMENT AND NOTICE FOR BEGINNERS 初學飛行調整與注意

★When arriving at the flying field.
★當抵達飛行場



- Check if the screws are firmly tightened.
- Check if the transmitter battery power and the helicopter battery power are fully charged.
- 再次確認→螺絲是否鎖固?
- 發射器和直昇機電池電力是否足夠。

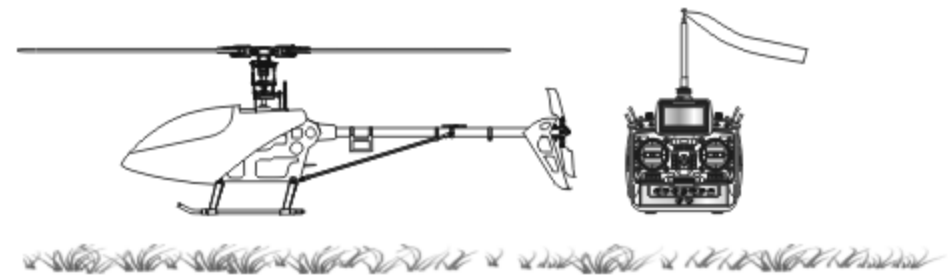

If there are other radio control aircraft at the field, make sure to check their frequencies and tell them what frequency you are using. Frequency interference can cause your model, or other models to crash and increase the risk of danger.
假使飛行場有其他遙控飛機，請確認他們的頻率，並告知他們你正在使用的頻率，相同的頻率會造成干擾導致失控和大大地增加風險。

STARTING AND STOPPING THE MOTOR 啟動和停止馬達



First check to make sure no one else is operating on the same frequency. Then place the throttle stick at lowest position and turn on the transmitter.
首先確認附近沒有其他相同頻率的使用，然後打開發射器將油門搖桿推到低點。

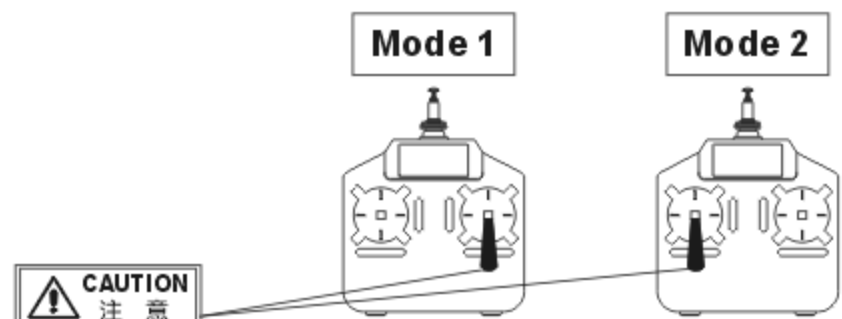

Check if the throttle stick is set at the lowest position. 確認油門搖桿是在最低的位置。

★Check the movement.
★動作確認

- Are the rudders moving according to the controls?
- Follow the transmitter's instruction manual to do a range test.
- 方向舵是否隨著控制方向移動?
- 根據發射器說明書進行距離測試。



ON! Step1
First turn on the transmitter.
先開啓發射器



ON! Step2
Connect to the helicopter power
接上直昇機電源



OFF! Step3
Reverse the above orders to turn off.
關閉電源時請依上述操作動作反執行。

Main rotor adjustments 主旋翼雙槳平衡調整



Tracking adjustment is very dangerous, so please keep away from the helicopter at a distance of at least 5m.
調整軌跡非常危險，請於距離飛機最少5公尺的距離。

1. Before adjusting, apply a red piece of tape on one blade, or paint a red stripe with a marker or paint to identify on blade.
 2. Raise the throttle stick slowly and stop just before the helicopter lifts-off ground. Look at the spinning blades from the side of the helicopter.
 3. Look at the path of the rotor carefully. If the two blades rotate in the same path, it does not need to adjustment. If one blade is higher or lower than the other blade, adjust the tracking immediately.
 4. Linkage rod (A): Regular pitch trim (For large variations). Linkage rod (D): Slight pitch trim (For slight variations).
1. 調整前先在其中一支主旋翼的翼端，貼上有顏色的貼紙或畫上顏色記號，方便雙槳調整辨識。
2. 慢慢的推起油門搖桿到高點並且停止，在飛機離開地面前，從飛機側邊觀察主旋翼轉動。
3. 仔細觀察旋翼軌跡(假如兩支旋翼移動都是相同軌跡，則不需要調整;可是如果一支旋翼較高或較低產生“雙槳”的情形時，則必須立刻調整軌跡)。
4. 連桿(A)為一般螺距調整(雙槳差異大時使用)。連桿(D)為螺距微調調整(雙槳微幅差異時使用)。

- A. When rotating, the blade with higher path means the pitch too big. Please lengthen pitch linkage rod (A) for regular trim or shorten linkage rod (D) for slight pitch trim.**
B. When rotating, the blade with lower path means the pitch too small. Please shorten pitch linkage rod (A) for regular trim or lengthen linkage rod (D) for slight pitch trim.

- A. 旋翼轉動時較高軌跡的主旋翼表示螺距(PITCH)過大，請調長連桿(A)修正，或需要更小的螺距微調時，請調短連桿(D)修正。
B. 旋翼轉動時較低軌跡的主旋翼表示螺距(PITCH)過小，請調短連桿(A)修正，或需要更小的螺距微調時，請調長連桿(D)修正。



Incorrect tracking may cause vibrations. Please repeat adjusting the tracking to make sure the rotor is correctly aligned. After tracking adjustment, please check the pitch angle is approx. +5° when hovering.

不正確的旋翼軌跡會導致震動，請不斷重複調整軌跡，使旋翼軌跡精準正確。在調整軌跡後，確認一下Pitch角度在停旋時應為大約+5°。



FLIGHT ADJUSTMENT AND NOTICE FOR BEGINNERS 初學飛行調整與注意



- ⊙ Make sure that no one or obstructions in the vicinity.
- ⊙ You must first practice hovering for flying safety. This is a basic flight action. (Hovering means keeping the helicopter in mid air in a fixed position)
- ⊙ 確認鄰近地區沒有人和障礙物。
- ⊙ 為了飛行安全，你必須先練習停旋，這是飛行動作的基礎（停旋：直昇機滯留空中並保持固定位置）。

- ⊙ Please stand approximately 5m diagonally behind the helicopter.
- ⊙ 練習時，請站在直昇機後方5公尺。

Beginner may install a training landing gear to avoid any crash caused by offset effect while landing.

必要時初學者可以在腳架下方安裝練習架，可避免降落時因重心偏移導致主旋翼或直昇機損毀。

STEP 1 THROTTLE CONTROL PRACTICE 油門控制練習

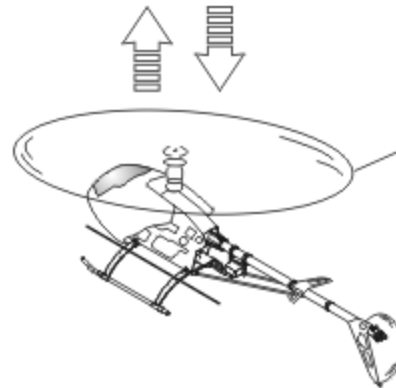
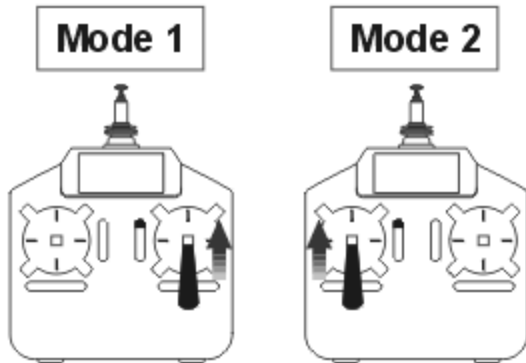

- ⊙ When the helicopter begins to lift-off the ground, slowly reduce the throttle to bring the helicopter back down. Keep practicing this action until you control the throttle smoothly.

- ⊙ 當直昇機開始離地時，慢慢降低油門將飛機降下。持續練習飛機從地面上升和下降直到你覺得油門控制很順。

STEP 2 AILERON AND ELEVATOR CONTROL PRACTICE 副翼和升降控制練習

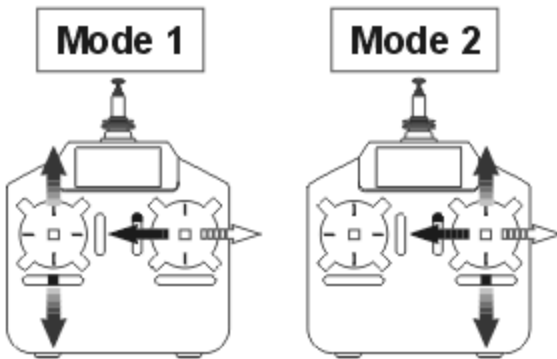

1. Raise the throttle stick slowly.
2. Move the helicopter in any direction back, forward, left and right, slowly move the aileron and elevator sticks in the opposite direction to fly back to its original position.

1. 慢慢升起油門搖桿。
2. 使直昇機依指示：移動向後/向前/向左/向右，慢慢的反向移動副翼和升降搖桿並將直昇機開回到原來位置。

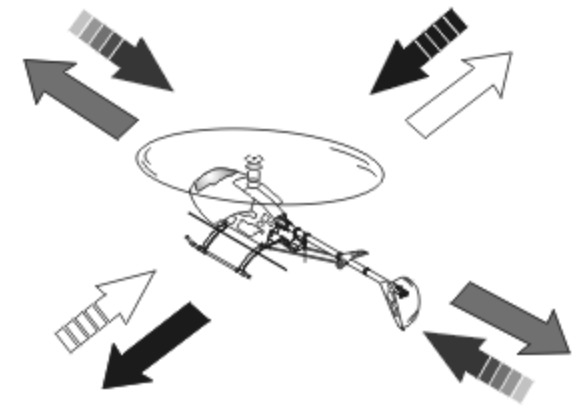

- ⊙ If the nose of the helicopter moves, please lower the throttle stick and land the helicopter. Then move your position diagonally behind the helicopter 5m and continue practicing.
- ⊙ If the helicopter flies too far away from you, please land the helicopter and move your position behind 5m and continue practicing.
- ⊙ 當直昇機機頭偏移時，請降低油門並且降落，然後移動自己的位置到直昇機的正後方5公尺再繼續練習。
- ⊙ 假如直昇機飛離你太遠，請先降落直昇機，並到直昇機後5公尺再繼續練習。

STEP 3 RUDDER CONTROL PRACTICING 方向舵操作練習

1. Slowly raise the throttle stick.
2. Move the nose of the helicopter to right or left, and then slowly move the rudder stick in the opposite direction to fly back to its original position.

1. 慢慢升起油門搖桿。
2. 將直昇機機頭移動左或右，然後慢慢反向移動方向舵搖桿並將直昇機飛回原本位置。

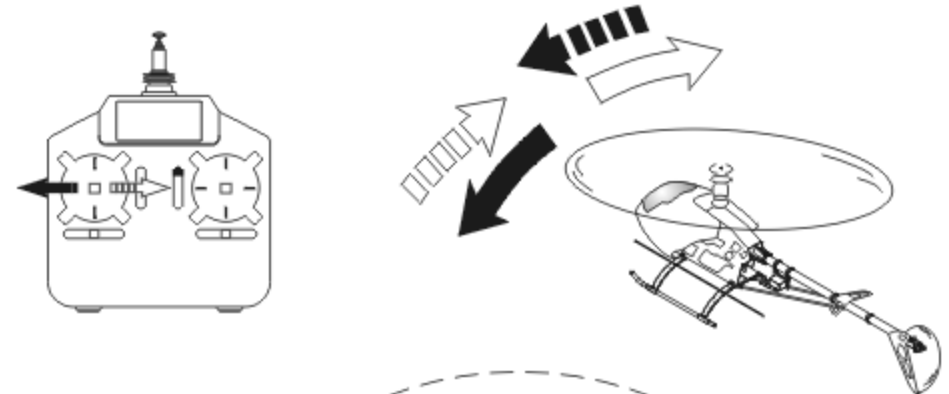

STEP 4

After you are familiar with all actions from Step1 to 3, draw a circle on the ground and practice within the circle to increase your accuracy.

當你覺得 step1-3 動作熟悉了，在地上畫圈圈並在這個圈圈的範圍內練習飛行，以增加你操控的準確度。

- ⊙ You can draw a smaller circle when you get more familiar with the actions.
- ⊙ 當你更加習慣操作動作，你可以畫更小的圈圈。

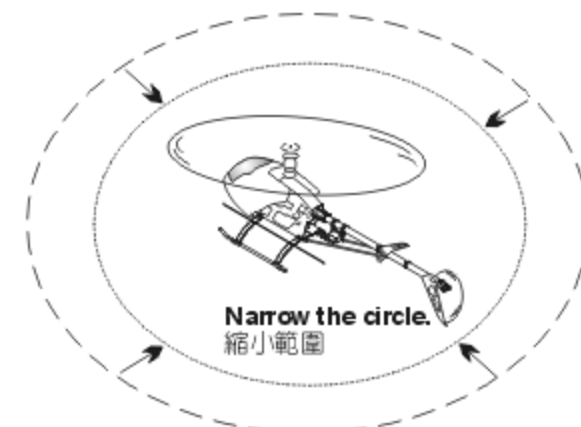

STEP 5 DIRECTION CHANGE AND HOVERING PRACTICE 改變直昇機方向和練習停旋

After you are familiar with Step1 to 4, stand at side of the helicopter and continue practicing Step1 to 4.

Then repeat the Step1 to 4 by standing right in front of the helicopter.

當你覺得step1-4動作熟悉了，站在面對直昇機側邊並繼續練習step1-4。之後，站在直昇機機頭右邊重複步驟練習。

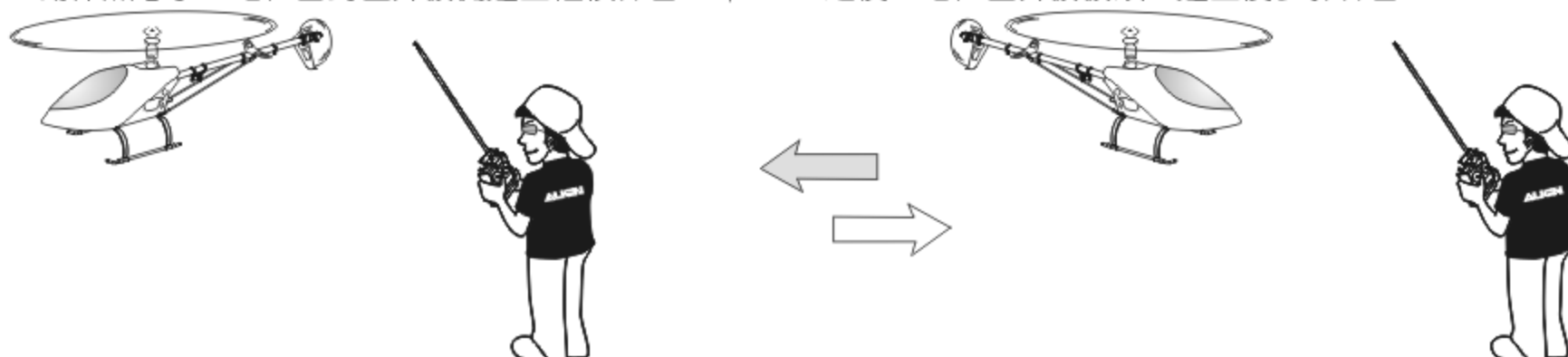

ADJUSTMENT OF EACH TRIM 飛行動作微調

Slowly raise the throttle stick and just as the helicopter lift-off the ground, you can use the trim to correct the action if the helicopter leans in a different direction.

慢慢升起油門搖桿，當直昇機剛剛離開地面時，若直昇機傾向不同方向，可使用微調修正動作。

1. Adjustment of Rudder trim 調整方向舵微調

Just before the helicopter lift-off, the nose lean left/right...

When leans right, adjust the trim to left side.
When leans left, adjust the trim to right side.

在直昇機正要起飛時，機頭朝左/右方向偏移...
向右偏移時，微調向左調整。
向左偏移時，微調向右調整。

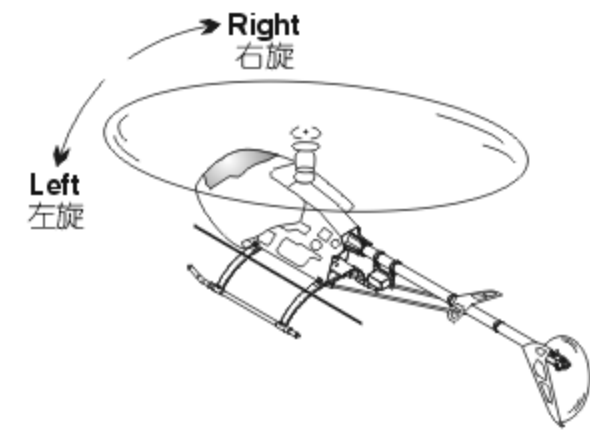
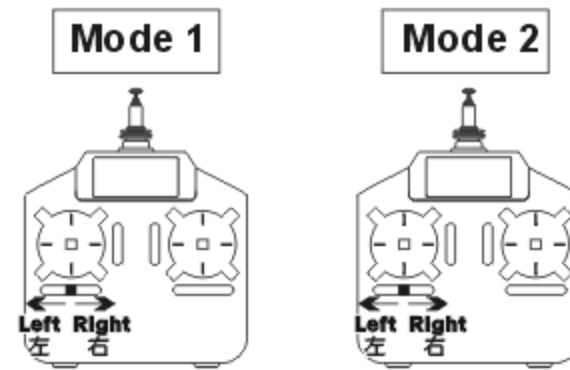

2. Adjustment of Elevator trim 調整升降舵微調

Just before the helicopter lift-off, the nose lean forward/backward...

When leans forward, adjust the trim down.
When leans backward, adjust the trim up.

在直昇機正要起飛時，機頭朝前/後方向偏移...
向前偏移時，微調向下調整。
向後偏移時，微調向上調整。

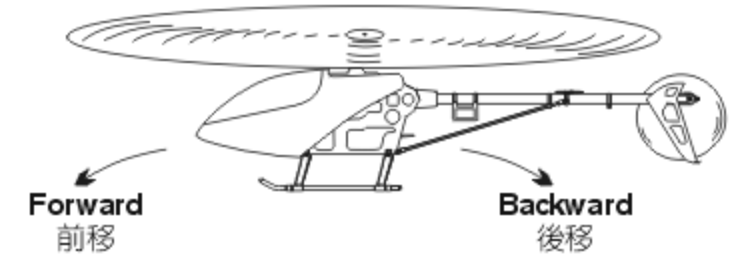
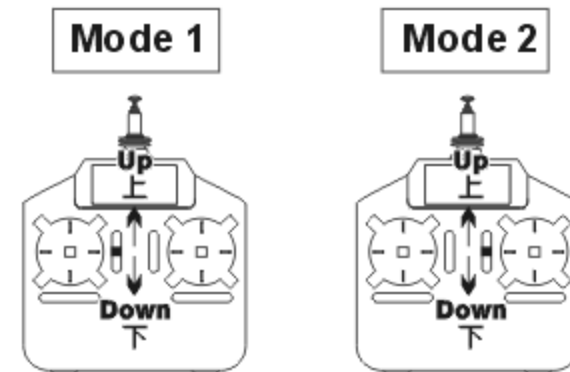

3. Adjustment of Aileron trim 調整副翼微調

Just before the helicopter lift-off, the body lean left/right...

When leans right, adjust the trim to left side.
When leans left, adjust the trim to right side.

在直昇機正要起飛時，機身朝左/右方向偏移...
向右偏移時，微調向左調整。
向左偏移時，微調向右調整。

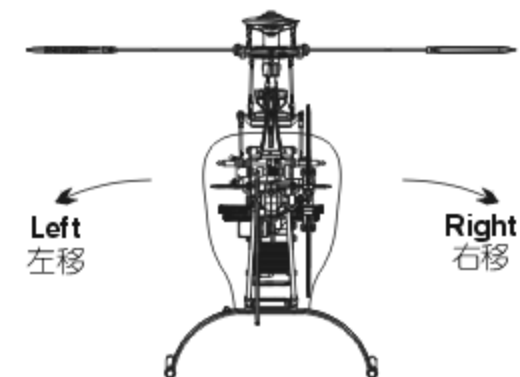
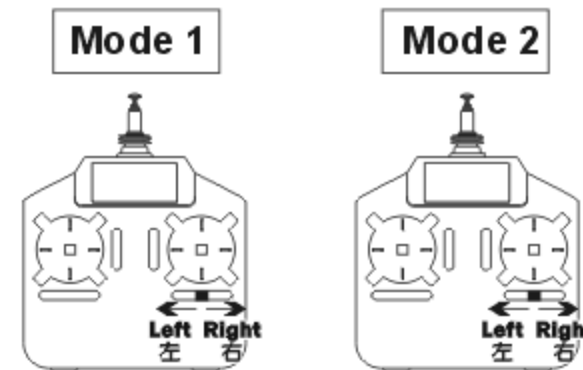

TROUBLE SHOOTING DURING FLIGHT 如何排除飛行中的狀況

	Situation 狀況	Cause 原因	Way to deal 對策
Blade Tracking 雙槳平衡	Out of tracking 雙槳	Adjustment of pitch rod has not been done. PITCH連桿長度調整不平均	Adjust the length of linkage rod(A) → Regular trim Adjust the length of linkage rod(D) → Slight trim 調整連桿(A)長度 → 一般調整 調整連桿(D)長度 → 微調整
During Hovering 停旋	Low rotation of the rotor 主旋翼轉速偏低	★ Pitch of main blade is high. ★ 主旋翼的PITCH偏高 ★ Throttle curve is too low during hovering. ★ 停旋點油門曲線過低	★ Lower the pitch about 5 degrees during hovering (The rotation should be about 2,000rpm during hovering). ★ 調低Pitch停旋Pitch約5° (停旋時主旋翼需為約2000RPM) ★ Heighten the throttle curve during hovering. ★ 調高停旋點油門曲線
	High rotation of the rotor 主旋翼轉速偏高	★ Pitch of main blade is low. ★ 主旋翼的PITCH偏低 ★ Throttle curve is too high during hovering. ★ 停旋點油門曲線過高	★ Adjust the pitch rod (A) (The rotation should be about 2,000rpm during hovering). ★ 調整連桿 (A) (停旋時主旋翼需為約2000RPM) ★ Lower the throttle curve during hovering. ★ 調低停旋點油門曲線
Sensitivity of the gyro 陀螺儀敏感度	The tail leans to one side during hovering, or when trim the rudder and return to the neutral, the tail lags and cannot stay in a control position. 停旋時尾翼向某一邊偏移，或撥動方向舵並回復到中立點時，尾翼產生延遲，無法停頓在所控制位置上。	★ Failure setting of tail neutral point. ★ 尾中立點設定不當 ★ The sensitivity of the gyro is low. ★ 陀螺儀敏感度偏低	★ Reset tail neutral point. ★ 重設尾中立點 ★ Increase the sensitivity. ★ 增加敏感度
	The tail wags left and right during flight at hovering or full speed. 停懸或全油門時尾翼左右來回搖擺。	The sensitivity of the gyro is high. 陀螺儀敏感度偏高	Decrease the sensitivity. 降低敏感度

※ If the problem is still there even after tried above, stop flying and contact with your seller.

※ 在做完以上調整後，仍然無法改善情況時，應立即停止飛行並連絡您的經銷商。

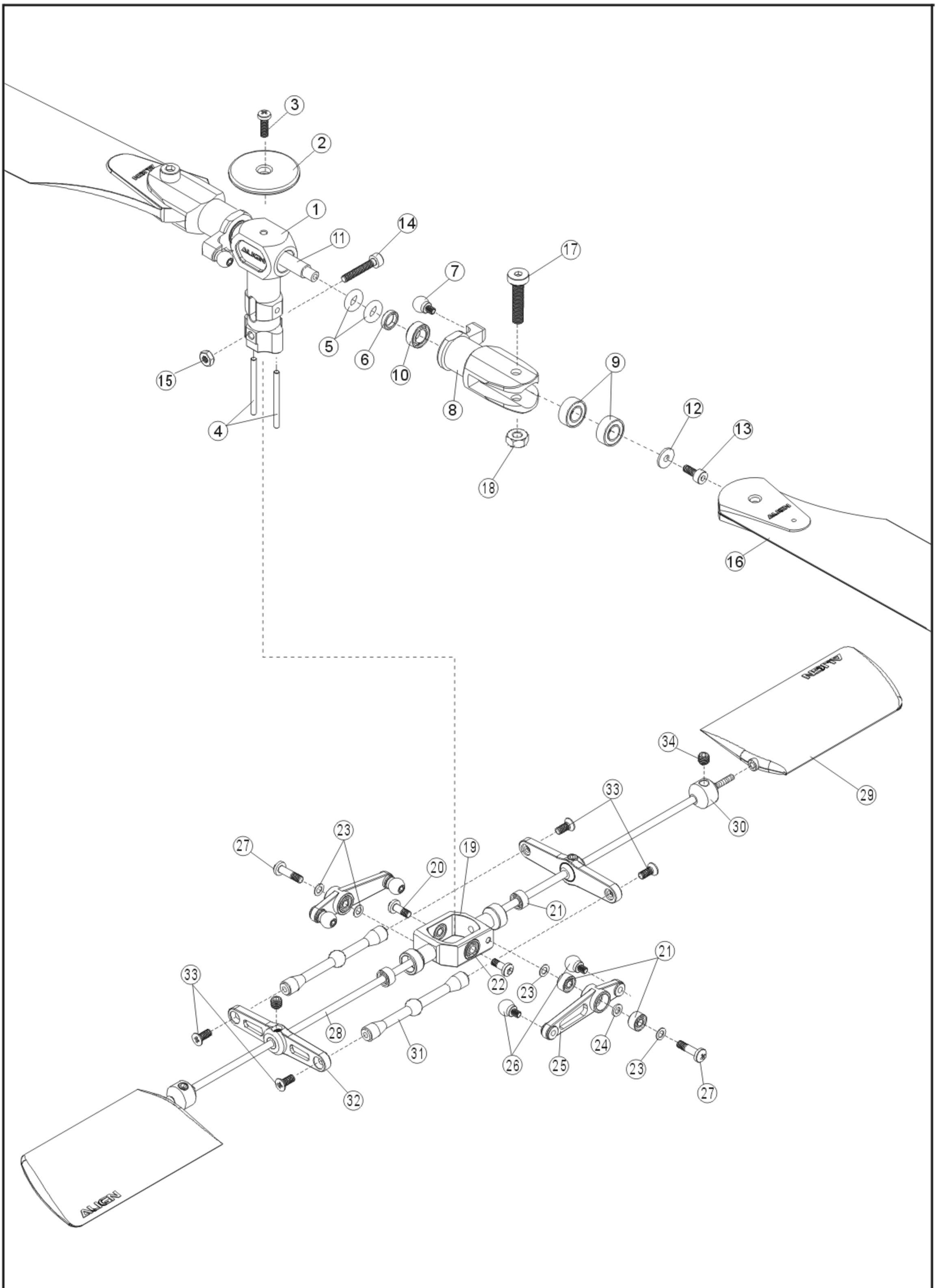

No.	Code No.	Name	Specification	Quantity	Remarks
1	HH2015	Metal main rotor housing 金屬主旋翼固定座	17x37.5x11mm	1	
2	HH2012L	Metal head stopper 金屬旋翼頭制動器	φ 18X6mm	1	
3	T12006	Screw 圓頭十字螺絲	M2X6mm	1	
4	HH2003-1	Pin 定位插銷	φ 1.5X18.7mm	2	
5	HH2004	O-Ring P3油封	φ 3X φ 6.5X2mm	4	
6	HH2005-1	Aluminum collar 橫軸鋁套	φ 3X φ 5X1.5mm	2	
7	HH4006S-1	Linkage ball A(M2x2.5) 球頭A(M2x2.5)	φ 4.75x7.18mm	2	
8	HH2010L	Metal main rotor holder 金屬主旋翼夾座	36.65X10.5mm	2	
9	HMR63ZZ	Bearing MR63ZZ 軸承MR63ZZ	φ 3X φ 6X2.5mm	2	
10	H693ZZ	Bearing 693ZZ 軸承693ZZ	φ 3X φ 8X4mm	4	
11	HH2007	Feathering shaft 橫軸	φ 4X41mm	1	
12	W10020	Washer 華司	φ 2X φ 6X0.6mm	2	
13	T52005	Socket screw 圓頭內六角螺絲	M2X5mm	2	
14	T52012	Socket screw 圓頭內六角螺絲	M2X12mm	1	
15	N10020-1	Nut 螺帽	M2	1	
16	HH3016	325 PRO Blade 325 PRO主旋翼	325mm	1 set	
17	T53014-1	Socket screw 圓頭內六角螺絲	M3X14mm	2	
18	N10030	Nut M3防鬆螺帽	M3	2	
19	HH4002L-1	Metal flybar seesaw holder 金屬平衡桿固定座	36X14.5X7mm	1	
20	T52055	Socket button head collar screw 半圓頭內六角軸套螺絲	M2X5.5mm	2	
21	HMR52ZZ	Bearing MR52ZZ 軸承MR52ZZ	φ 2X φ 5X2.5mm	6	
22	HFMR52ZZ	Bearing FMR52ZZ 軸承FMR52ZZ	φ 2X φ 5X φ 6X2.3mm	2	
23	W10020-1	Washer 華司	φ 2X φ 3.6X0.2mm	4	
24	W10020-2	Washer 華司	φ 2X φ 3.6X0.5mm	2	
25	HH4005AL	Metal SF mixing arm 金屬SF控制搖臂	31.45X5.5mm	2	
26	HH4006S-1	Linkage ball A(M2x2.5) 球頭A(M2x2.5)	φ 4.75x7.18mm	4	
27	T12008-2	Collar screw 軸套螺絲	M2X8mm	2	
28	HH4003-2	Flybar rod 平衡翼桿	φ 1.97X220mm	1	
29	HH4022	Flybar paddle 平衡翼		2	
30	HH4018	Flybar weight 平衡翼重錘	φ 7.5X8mm	2	
31	HH4012S	Flybar control rod 平衡翼控制球桿	φ 4.3X39mm	2	
32	HH4014	Flybar control arm 平衡翼T型控制臂	38.3X4.5mm	2	
33	S72005-3	Cross screw 圓頭十字螺絲	M2X5mm	4	
34	T73003	Set screw 止洩螺絲	M3X3mm	4	

Specifications, contents of parts and availability are subject to change, Align RC is not responsible for inadvertent errors in this publications.
 本說明書內的材質、規格或零件包裝之內容物僅供參考。本公司將不對此印刷物之異動負責，也無法主動通知消費者，任何更新或異動，請以亞拓網頁為主。

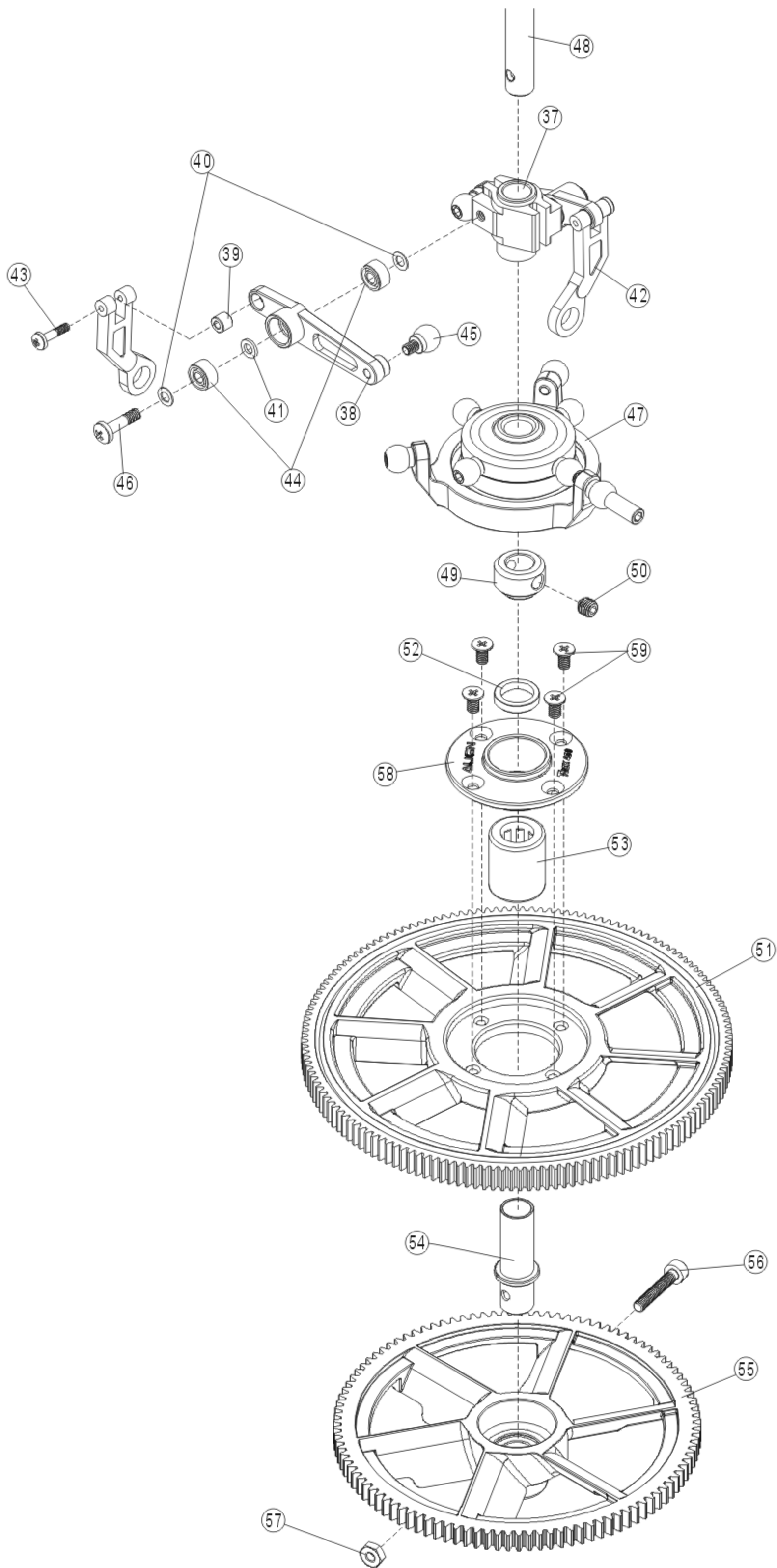

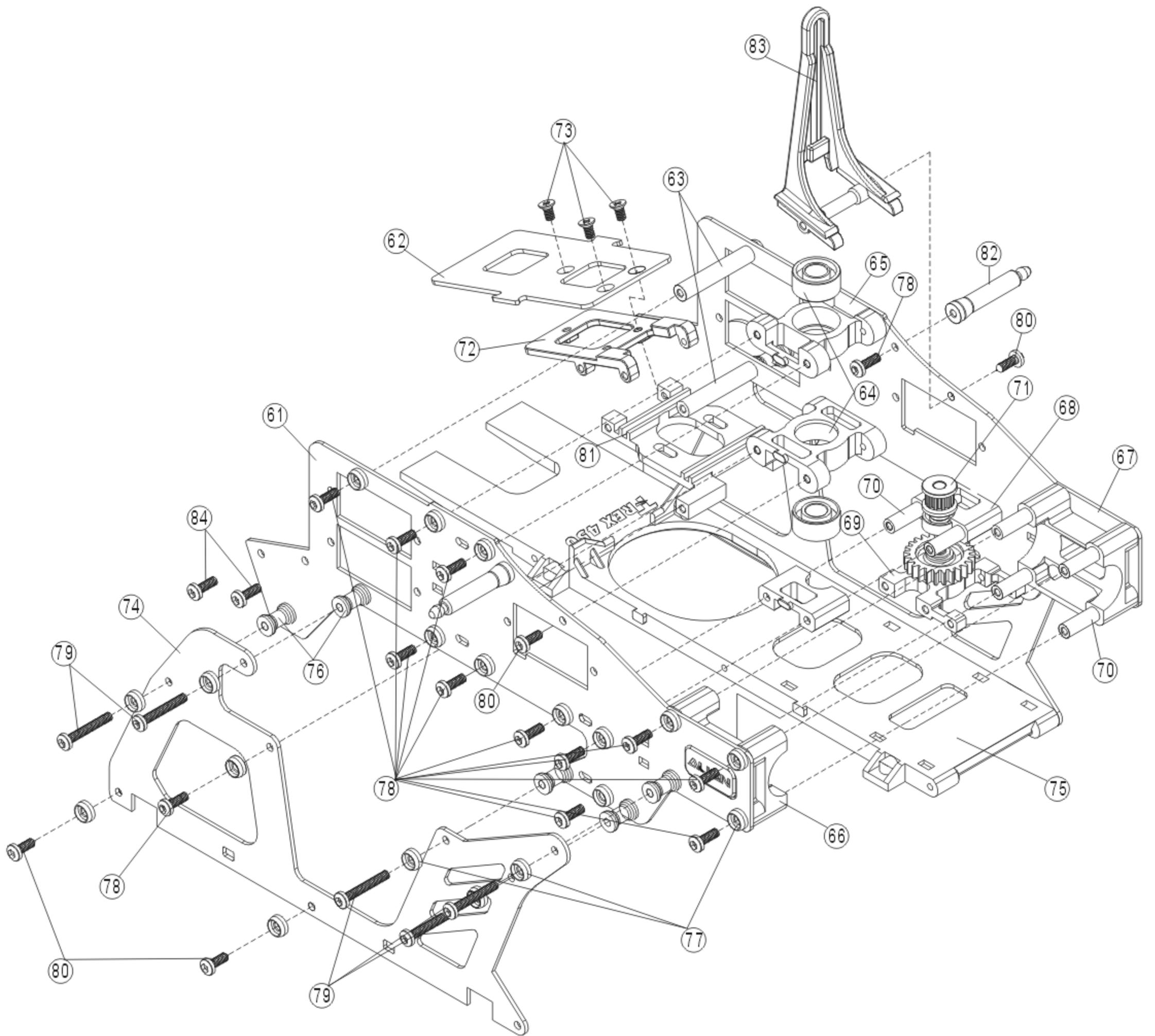

No.	Code No.	Name	Specification	Quantity	Remarks
37	HH5002L-2	Metal washout base 金屬向位器	13X13X10mm	1	
38	HH5003AL-1	Metal washout control arm 金屬穩定控制搖臂	32.5X5.5mm	2	
39	HH5008	Collar 穩定翼控制臂銅套	φ 1.4X φ 3X2.4mm	2	
40	W10020-1	Washer 華司	φ 2X φ 3.6X0.2mm	4	
41	W10020-2	Washer 華司	φ 2X φ 3.6X0.5mm	2	
42	HH5003B-3	Radius arm Radius連桿		2	
43	S41465	Collar screw 軸套螺絲	M1.4X6.5mm	2	
44	HMR52ZZ	Bearing MR52ZZ 軸承MR52ZZ	φ 2X φ 5X2.5mm	4	
45	HH4006S-1	Linkage ball A(M2x2.5) 球頭A(M2x2.5)	φ 4.75x7.18mm	2	
46	T12008-2	Collar screw 軸套螺絲	M2X8mm	2	
47	HH5004A-5	CCPM Swashplate CCPM十字盤組		1 set	
48	HH6002-2	Main shaft 主軸	φ 5X116mm	1	
49	HH6003	Lock ring 主軸固定套	φ 5X6mm	1	
50	T73003	Set screw 止洩螺絲	M3X3mm	1	
51	HB6006	New main drive gear 新型主齒輪	150T	1	
52	HB6003-2	Shaft ring 單向軸套圈	φ 6X φ 8X1.6mm	1	
53	HF0612-1	One-way bearing 單向軸承	φ 6X φ 10X12mm	1	
54	HB6002	One-way bearing shaft 單向軸承套	φ 5X φ 6X21.5mm	1	
55	HB6007	New autorotation tail drive gear 新型尾驅動主齒	106T	1	
56	T52012	Socket screw 圓頭內六角螺絲	M2X12mm	1	
57	N10020-1	Nut 螺帽	M2	1	
58	HB6008	450 Main gear case 450主齒中心座	φ 10X φ 21.5X7.8mm	1	
59	S72004-1	Cross screw 皿頭十字螺絲	M2x4mm	4	

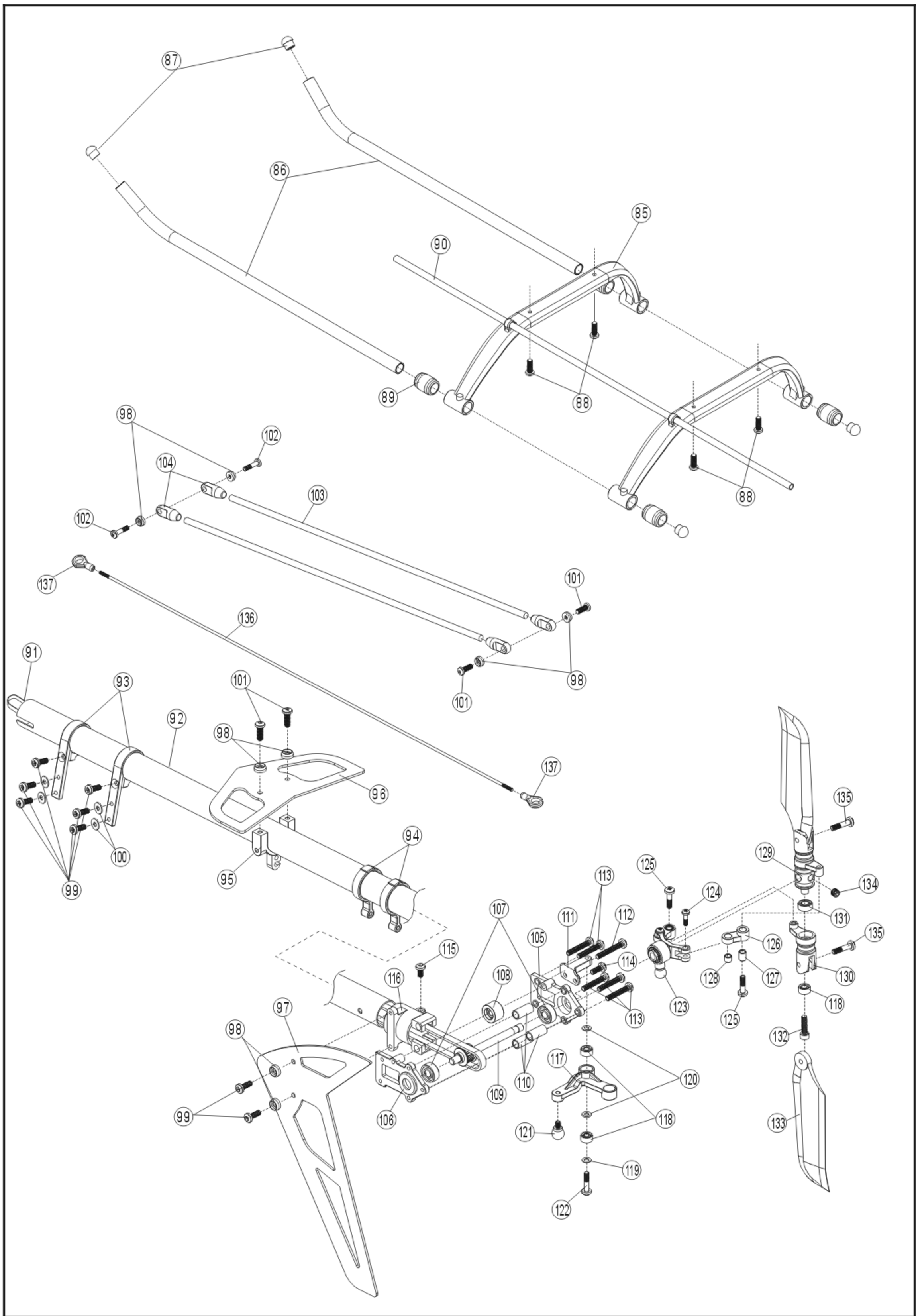

No.	Code No.	Name	Specification	Quantity	Remarks
61	HB2027	Glass fiber upper frame 玻纖上側板	161.14X58.25X1.2mm	2	
62	HB2029	Glass fiber battery mounting plate 玻纖電池座	50X36X1.2mm	1	
63	HB2005CF	Frame mounting bolt 機身鋁固定柱	φ 4X22mm	2	
64	HB9001CF	Metal main shaft mount 金屬主軸固定座	23X22X7mm	2	
65	H685ZZ	Bearing 685ZZ 軸承685ZZ	φ 5X φ 11X5mm	2	
66	HB1112	Metal tail boom mount(L) 金屬尾管固定座(左)	27.5X21.7X11.5mm	1	
67	HB1113	Metal tail boom mount(R) 金屬尾管固定座(右)	27.5X21.7X11.5mm	1	
68	HB1110CF-1	Metal upper bearing block 金屬尾組培林上固定座	18X11X3.5mm	2	
69	HB1111CF	Metal lower bearing block 金屬尾組培林下固定座	25X22X4mm	1	
70	HB9002CF	Aluminum tube 鋁套管	φ 3.5X19.7mm	6	
71	HB3001-5	Tail drive gear assembly 尾旋翼傳動輪組		1set	
72	HB1002CF-1	Aluminum battery mount 電池鋁座	36X22X5.75mm	1	
73	S72004-1	Cross screw 皿頭十字螺絲	M2X4mm	3	
74	HB2028	Glass fiber lower frame 玻纖下側板	147X62.9X1.2mm	2	
75	HB1006CF	Bottom plate 底板	172.5X39X5mm	1	
76	HB2014CF	Aluminum link 上下側板接合鋁柱	φ 2X φ 5X7.5mm	10	
77	HB2015CF	M2 specialty washer M2特殊華司	φ 2X φ 5X2mm	38	
78	T52006	Socket button head screw 半圓頭內六角螺絲	M2X6mm	26	
79	T52014	Socket button head screw 半圓頭內六角螺絲	M2X14mm	10	
80	T52006-1	Socket button head self tapping screw 半圓頭內六角鐵板螺絲	T2X6mm	6	
81	HB1001CF-1	Metal motor mount 金屬馬達固定座	36.4X39mm	1	
82	HB2006CF	Canopy mounting bolt 機頭罩鋁固定柱	φ 5X24.5mm	2	
83	HB4007-1	Anti rotation bracket spacer 十字盤導板		1	
84	T52004	Socket button head screw 半圓頭內六角螺絲	M2X4mm	4	

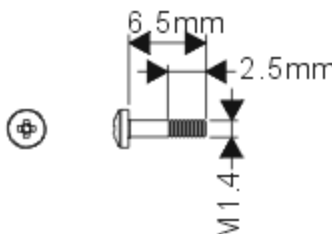
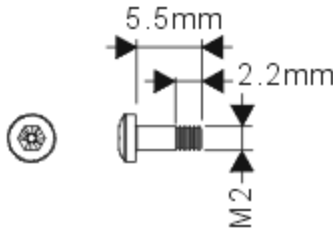
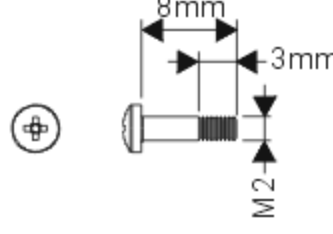
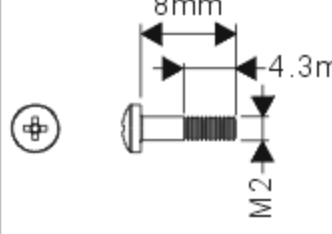
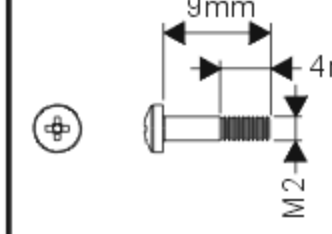
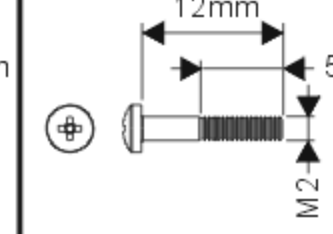
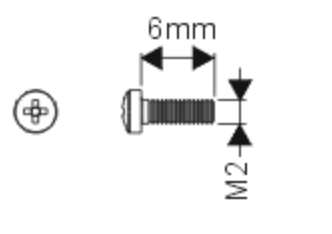
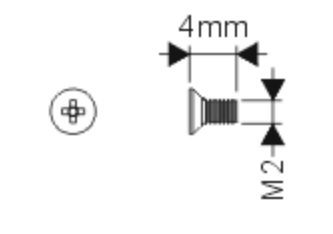
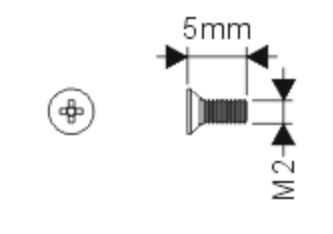
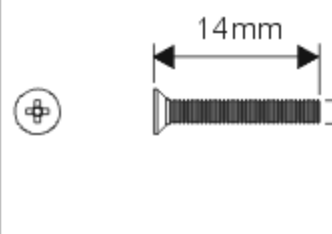
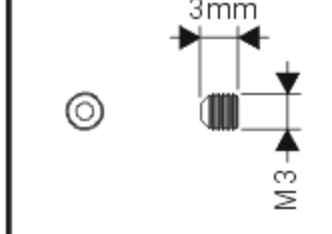
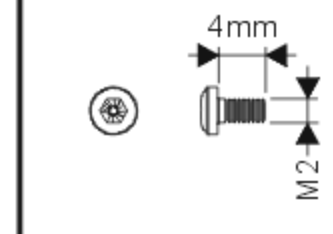
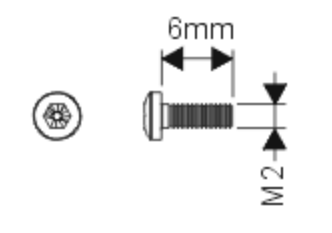
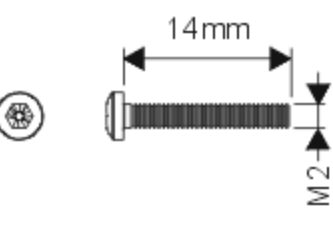
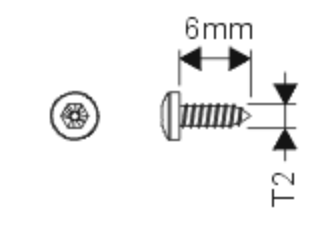
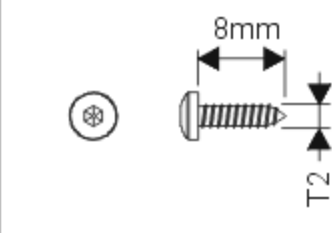
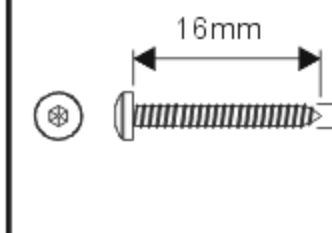
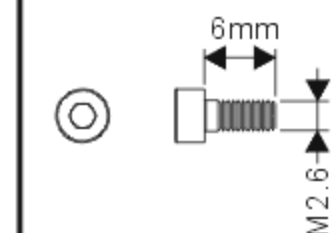
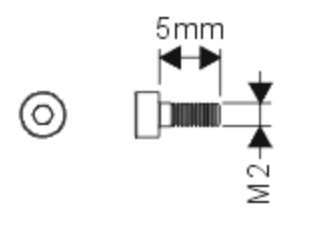
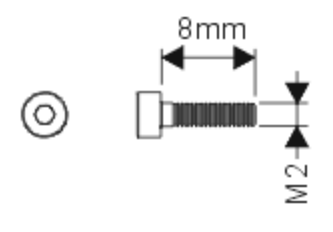
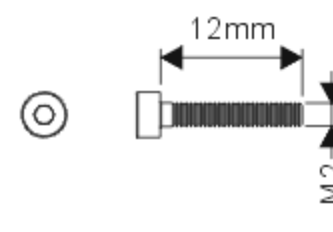
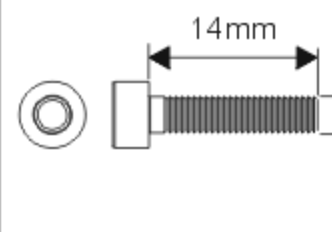
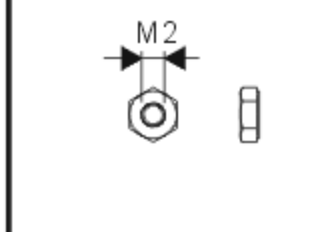
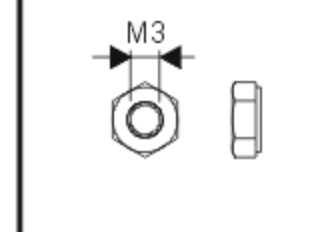
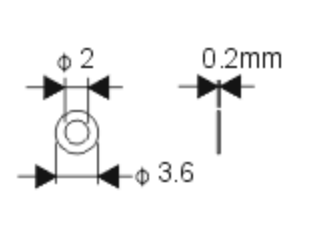
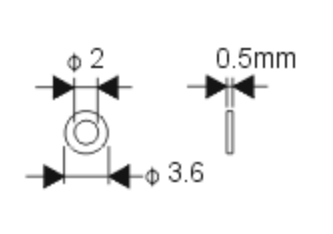
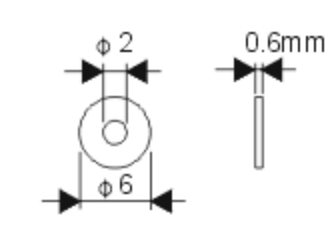
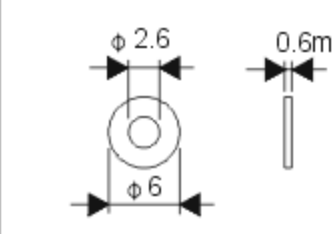
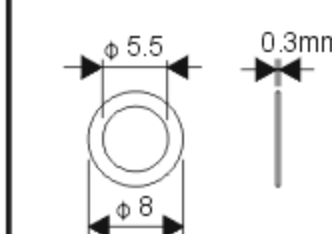
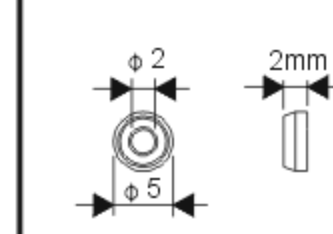
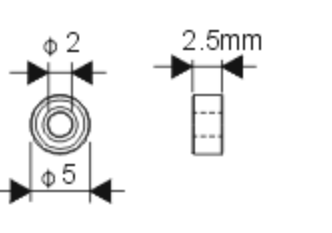
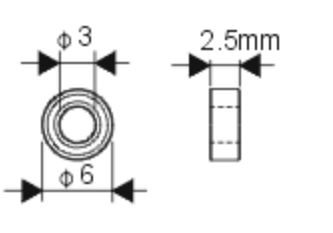
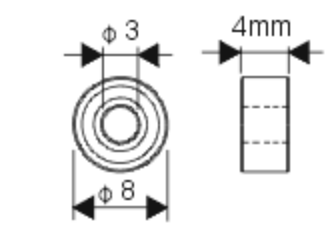
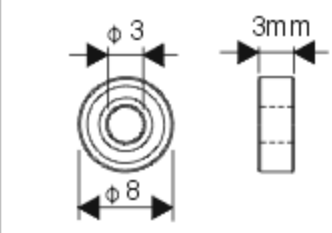
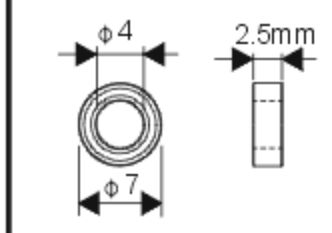
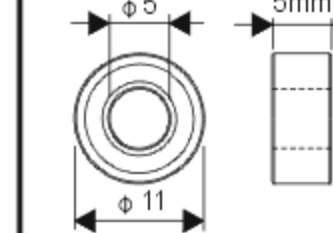
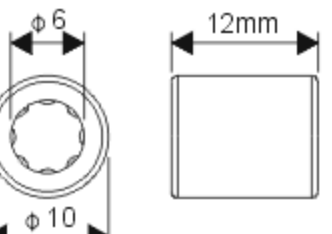

No.	Code No.	Name	Specification	Quantity	Remarks
85	HF2002-2	Landing skid 腳架		2	
86	HF2003	Skid pipe 腳架鋁管	φ 5.5X180mm	2	
87	HF2004	Skid pipe end cap 腳架鋁管保護套	φ 4.5X φ 2.5mm	4	
88	T52008-1	Socket button head self tapping screw 半圓頭內六角鐵板螺絲	T2X8mm	4	
89	K10181-1	Landing skid nut 起落架襯墊	φ 5X φ 8.5X10mm	4	
90	HF2007	Antenna pipe 天線管	φ 3X300mm	1	
91	HT1003	Tail drive belt 尾傳動皮帶	397MXL	1	
92	HT2004	Tail boom 尾管	φ 12X347mm	1	
93	HT2002CF-1	Metal tail servo mount 金屬尾伺服器座		2	
94	HT9004	Tail control guide 尾控制桿固定環	φ 12.2X φ 14.6X4mm	2	
95	HT3003	Stabilizer mount 水平翼固定座		1	
96	HT3013	Glass Fiber horizontal stabilizer 玻纖水平翼		1	
97	HT3014	Glass Fiber vertical stabilizer 玻纖垂直翼		1	
98	HB2015CF	M2 specialty washer M2特殊華司	φ 2X φ 5X2mm	8	
99	T52006	Socket button head screw 半圓頭內六角螺絲	M2X6mm	8	
100	W10020	Washer 華司	φ 2X φ 6X0.6mm	4	
101	T52008-1	Socket button head self tapping screw 半圓頭內六角鐵板螺絲	T2X8mm	4	
102	T12009-1	Collar screw 軸套螺絲	M2X9mm	2	
103	HT2003A	Tail boom brace 尾管支撐架	φ 3X205mm	2	
104	HT2003S	Tail boom brace end 金屬尾管支撐架接頭		4	
105	HT4001CF-1	Metal tail unit housing(R) 金屬尾齒輪座(右)	29.5X14.75X3.7mm	1	
106	HT4002CF-1	Metal tail unit housing(L) 金屬尾齒輪座(左)	29.5X14.75X3.7mm	1	
107	HMR83ZZ	Bearing MR83ZZ 軸承MR83ZZ	φ 3X φ 8X3mm	2	
108	HT4003CF-1	Tail pulley assembly 尾皮帶導輪組		1set	
109	HT5001CF-1	Tail rotor shaft assembly 尾旋翼主軸組		1set	
110	HT4008CF	Aluminum collar 尾組齒輪座鋁套	φ 3X φ 4X8.5mm	3	
111	HT4007CF	Control arm holder 金屬尾控制臂固定座	11x22mm	1	
112	T52014	Socket button head screw 半圓頭內六角螺絲	M2X14mm	1	
113	T52012-1	Socket button head screw 半圓頭內六角螺絲	M2X12mm	5	
114	T52004	Socket button head screw 半圓頭內六角螺絲	M2X4mm	1	
115	T52006	Socket button head screw 半圓頭內六角螺絲	M2X6mm	1	
116	HT4006CF	Tail gear case 金屬尾組齒輪固定座	φ 14X20X20mm	1	
117	HT4009	Tail rotor control arm 尾旋翼控制臂	18.5x14mm	1	
118	HMR52ZZ	Bearing MR52ZZ 軸承MR52ZZ	φ 2X φ 5X2.5mm	4	
119	W10020-1	Washer 華司	φ 2X φ 3.6X0.2mm	1	
120	W10020-2	Washer 華司	φ 2X φ 3.6X0.5mm	2	
121	50H012-1	Linkage ball A(M2x3.5) 球頭A(M2x3.5)	φ 4.75X8.18mm	1	
122	T12009-1	Collar screw 軸套螺絲	M2X9mm	1	
123		Tail pitch assembly 尾旋翼控制組		1set	
124	T12006-1	Collar screw 軸套螺絲	M2X6mm	2	
125	T12008-4	Collar screw 軸套螺絲	M2X8mm	2	
126	HT7003B	Control ball link 尾控制連桿頭	φ 5.1X11.58X4.2mm	2	
127	50T106	Collar A 尾連桿頭銅套A	φ 2X φ 3X4mm	2	
128	HT7003C	Collar B 尾連桿頭銅套B	φ 2X φ 3X2.5mm	2	
129	HT6001S-2	Tail rotor hub 尾旋翼T型座	φ 8X18.2mm	1	
130	HT6006L-2	Metal tail rotor holder 金屬尾旋翼夾座		2	
131	HMR63ZZ	Bearing MR63ZZ 軸承MR63ZZ	φ 3X φ 6X2.5mm	2	
132	T52008	Socket screw 圓頭內六角螺絲	M2X8mm	2	
133	HT6011	Tail rotor blade 尾旋翼	60.75x2.2mm	2	
134	T73003	Set screw 止洩螺絲	M3X3mm	1	
135	T12008-2	Collar screw 軸套螺絲	M2X8mm	2	
136	HT9003	Rudder control rod 尾舵控制連桿	φ 1.3X280mm	1	
137	HZ009-1	Ball link(Long) 連桿頭(長)		2	

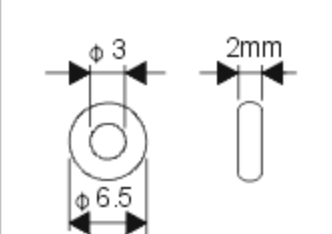
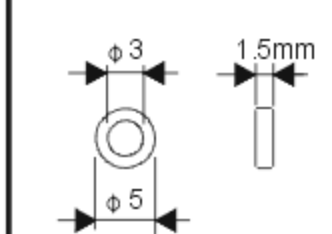
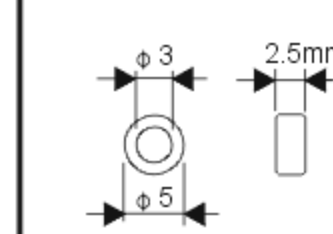
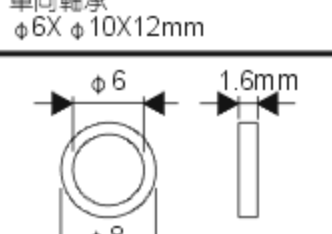
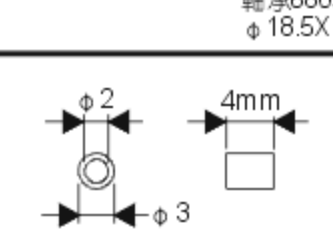
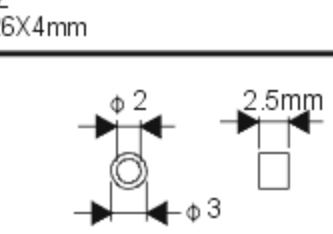
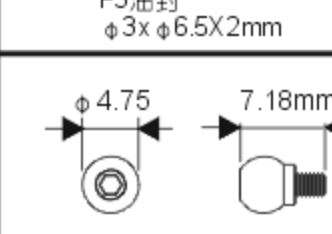
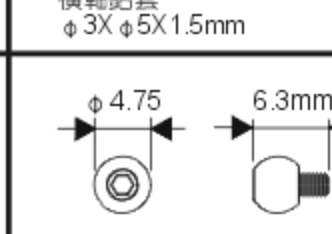
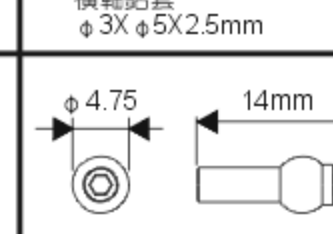
 <p>Collar screw 轉套螺絲 M1.4X6.5mm</p>	 <p>Socket button head collar screw 半圓頭內六角轉套螺絲 M2X5.5mm</p>	 <p>Collar screw 轉套螺絲 M2X8mm</p>	 <p>Collar screw 轉套螺絲 M2X8mm</p>	 <p>Collar screw 轉套螺絲 M2X9mm</p>	 <p>Collar screw 轉套螺絲 M2X12mm</p>
 <p>Screw 圓頭十字螺絲 M2X6mm</p>	 <p>Cross screw 圓頭十字螺絲 M2X4mm</p>	 <p>Cross screw 圓頭十字螺絲 M2X5mm</p>	 <p>Cross screw 圓頭十字螺絲 M2X14mm</p>	 <p>Set screw 止洩螺絲 M3X3mm</p>	 <p>Socket button head screw 半圓頭內六角螺絲 M2X4mm</p>
 <p>Socket button head screw 半圓頭內六角螺絲 M2X6mm</p>	 <p>Socket button head screw 半圓頭內六角螺絲 M2X14mm</p>	 <p>Socket button head self tapping screw 半圓頭內六角鐵板螺絲 T2X6mm</p>	 <p>Socket button head self tapping screw 半圓頭內六角鐵板螺絲 T2X8mm</p>	 <p>Socket button head self tapping screw 半圓頭內六角鐵板螺絲 T2X6mm</p>	 <p>Socket screw 圓頭內六角螺絲 M2.6X6mm</p>
 <p>Socket screw 圓頭內六角螺絲 M2x5mm</p>	 <p>Socket screw 圓頭內六角螺絲 M2x8mm</p>	 <p>Socket screw 圓頭內六角螺絲 M2x12mm</p>	 <p>Socket screw 圓頭內六角螺絲 M3x14mm</p>	 <p>Nut 六角螺帽 M2</p>	 <p>Nut 防鬆螺帽 M3</p>
 <p>Washer 華司 φ2X φ3.6X0.2mm</p>	 <p>Washer 華司 φ2X φ3.6X0.5mm</p>	 <p>Washer 華司 φ2X φ6X0.6mm</p>	 <p>Washer 華司 φ2.6X φ6X0.6mm</p>	 <p>Washer 華司 φ5.5X φ8X0.3mm</p>	 <p>M2 specialty washer M2特殊華司 φ2X φ5X2mm</p>
 <p>Bearing MR52ZZ 軸承MR52ZZ φ2X φ5X2.5mm</p>	 <p>Bearing MR63ZZ 軸承MR63ZZ φ3X φ6X2.5mm</p>	 <p>Bearing MR693ZZ 軸承MR693ZZ φ3X φ8X4mm</p>	 <p>Bearing MR83ZZ 軸承MR83ZZ φ3X φ8X3mm</p>	 <p>Bearing MR74ZZ 軸承MR74ZZ φ4X φ7X2.5mm</p>	 <p>Bearing 685ZZ 軸承685ZZ φ5X φ11X5mm</p>
 <p>One-way bearing 單向軸承 φ6X φ10X12mm</p>	 <p>Bearing 6803ZZ 軸承6803ZZ φ18.5X φ26X4mm</p>		 <p>O-Ring P3油封 φ3x φ6.5X2mm</p>	 <p>Aluminum collar 橫軸鋁套 φ3X φ5X1.5mm</p>	 <p>Aluminum collar 橫軸鋁套 φ3X φ5X2.5mm</p>
 <p>One-way shaft ring 單向軸套圈 φ6X φ8X1.6mm</p>	 <p>Collar A 尾連桿頭鋼套A φ2X φ3X4mm</p>	 <p>Collar B 尾連桿頭鋼套B φ2X φ3X2.5mm</p>	 <p>Linkage ball A (M2x2.5) 球頭A (M2x2.5) φ4.75x7.18mm</p>	 <p>Linkage ball E (M2x2.5) 球頭E (M2x2.5) φ4.75x6.3mm</p>	 <p>Long linkage ball (M2x3) 導板長球頭 (M2x3) φ4.75x14mm</p>

Specifications & Equipment/規格配備:

Length/機身長: 650mm (25.6 in)

Height/機身高: 230mm (9.1 in)

Main Blade Length/主旋翼長: 325mm

Main Rotor Diameter/主旋翼直徑: 700mm (27.6 in)

Tail Rotor Diameter/尾旋翼直徑: 150mm (5.9 in)

Motor Pinion Gear/馬達主齒: 12T/13T

Main Drive Gear/傳動主齒輪: 150T

Autorotation Tail Drive Gear/尾驅動主齒: 106T

Tail Drive Gear/尾翼傳動齒: 25T

Drive Gear Ratio/齒輪傳動比: 1:12.5:4.24/1:11.5:4.24

Weight(w/o main blade)/空機重: Approx 430g(0.95 lbs)

Flying Weight/全配重: Approx 690g(1.52 lbs)

