

# ***Swift Carbon 550***

## ***ELECTRIC R/C HELICOPTER***

### ***Kit Instruction Manual***



#### Mechanical Specs:

Main Rotor Blades: 520-550mm

Tail Rotor Blades: 75-85mm

Length: 105cm

Height: 34.4cm

Weight: 1.54kg (configured with brushless motor and servos)

#### Electronic Specs:

Speed Control: 50-80 Amp

Motor: 900-1250kv (based on battery)

Battery: 4S-6S Li-Po or 12 cell NiMH or NiCd

Main Gear: 96 Tooth

Pinion: 9-15 Tooth

Head Speed: 1600-2100 RPM

# **Century Helicopter Products**

Designed and Developed in USA

1st Edition June 2007 All rights reserved.

# 1. Introduction

Congratulations on your purchase of Century Helicopter Product's Swift Carbon 550 Kit. The Swift Carbon 550 is a high performance machine providing the agility and durability that is expected out of a helicopter of this caliber. The attention and praise by the R/C helicopter community is well deserved as the Century Swift line is unmatched in affordability, quality and performance.

In order to take advantage of your Swift's performance capabilities we recommend using a high quality computer radio system with 120 degree eCCPM mixing. The radio system should have at least 6 channels to use modern heading lock gyros, Standard servos can be used with a specialized high speed tail servo.

## Warning

This radio controlled model is not a toy! It is a precision machine requiring proper assembly and setup to avoid accidents. It is the responsibility of the owner to operate this product in a safe manner as it can inflict serious injury otherwise. It is recommended that if you are in doubt of your abilities, seek assistance from experienced radio control modelers and associations. As manufacturer, we assume no liability for the use of this product.

## Pre-assembly Information

Upon opening the kit, all components are in individual bags. Please thoroughly read through this manual before attempting assembly. Some specialized tools are recommended but not required for full assembly. Be careful when opening each bag as not to lose any hardware. As a reminder, all metal to metal screw assemblies require "blue" thread lock compound, all metal to plastic screw assemblies require slow setting CA and all bearing race to metal shafts should use "red" thread lock compound.

## Warranty

Your new equipment is warranted to the original purchaser against manufacturer defects in material and workmanship for 30 days from the date of purchase. During this period, Century Helicopter Products will repair or replace, at our discretion, any component that is found to be factory defective at no cost to the purchaser. This warranty is limited to the original purchaser and is not transferable. This warranty does not apply to any unit which has been improperly installed, mishandled, abused, or damaged in a crash, or to any unit which has been repaired or altered by any unauthorized agencies. Under no circumstances will the buyer be entitled to consequential or incidental damages. This limited warranty gives you specific legal rights. You also have other rights which may vary from state to state.

## Century Helicopter Products

1740-C Junction, Ave.  
San Jose, CA 95112  
Fax: 408-451-1156  
[www.centuryheli.com](http://www.centuryheli.com)

# Lithium Polymer Battery Safety

For Lithium Polymer and NiMH/NiCD cell or battery packs purchased.

1. Never fast-charge any battery type unattended.
2. Never charge Li-Poly cells or battery packs at any rate unattended.
3. Only charge Li-Poly cells or battery packs with a charger designed specifically for lithium polymer chemistry.
4. Li-Poly cells can ignite because of unmatched cell capacity or voltage, cell damage, charger failure, incorrect charger setting and other factors.
5. Always use the correct charging voltage. Li-Poly cells or battery packs may ignite if connected to a charger supplying more than 5 volts per cell.
6. Always assure the charger is working properly.
7. Always charge Li-Poly cells or battery packs where no harm can result, no matter what happens. We suggest a brick box or likeness. Have sand handy in a bucket for any need to extinguish any fire. NEVER use water on any cells or battery packs.
8. Never charge a cell or battery pack in a model. A hot pack may ignite wood, foam, plastic, etc.
9. Never charge a cell or battery pack inside a motor vehicle or in a vehicle's engine compartment.
10. Never charge a cell or battery pack on a wooden workbench or on any flammable material.
11. If a cell or battery pack is involved in a crash:
  - a. Remove the cell or battery pack from model.
  - b. Carefully inspect the cell or battery pack for shorts in the wiring or connections. If in doubt, cut all wires from cell or battery pack.
  - c. Disassemble the pack
  - d. Inspect cells for dents, cracks and splits. Dispose of damaged cells.
12. Dispose of cells or battery packs as follows:
  - a. Discharge: with the cells or battery pack in a safe area, connect a moderate resistance across the terminals until the cell or battery pack is discharged. CAUTION: cell or battery pack may be hot.
  - b. Discard:
    - i. NiMH: place in regular trash
    - ii. NiCD: recycle (cadmium is toxic)
    - iii. Li-Poly: puncture plastic envelope, immerse in salt water for several hours and place in regular trash.
13. Handle all cells or battery packs with care, as they can deliver high currents if shorted. Shorting by a wedding ring, for example, will remove a finger.
14. Always store cells or battery packs in a secure location where they cannot be shorted or handled by children.
15. When constructing a battery pack, always use cells of the same capacity (mAh)
16. DO NOT store fully charged or discharged batteries in your helicopter.
17. When cutting wires, always cut ONLY ONE WIRE AT A TIME.

\*\* Century Helicopter Products will not be liable for any damages that may occur to your helicopter due to any misuse or mishandling as explained above.

\*\* Century Helicopter Products, its successors, heirs and assignees are not responsible in way for any and all bodily injuries) and/or property damage that may occur from the use of, or caused by in any way from Lithium Polymer and NiMH/NiCD cells or battery packs offered by and or distributed by Century Helicopter Products.

### 3. Required Items for Operation

This is the general list of items required to get the Swift Carbon 550 helicopter flying. Century produces a full spectrum of accessories and tools to assemble your helicopter. The Swift Carbon 550 is an electronic cyclic collective pitch mixing type helicopter requiring a standard helicopter radio (the helicopter radio requires eCCPM mixing for this model). The Swift Carbon 550 uses 4 servos to operate critical systems. Gyroscopes are required to operate the model safely.

#### Necessary Items "Not Included" in the kit.

Transmitter



PG2000 II Dual Rate Piezo Gyro #CN2018 (or equivalent)



Brushless Electric Motor Century Outrunner 550/600 PLUS # CNE271/CNE273

Servos (4)



Receiver



Receiver Battery Pack



Electron 80/100 Brushless Speed Control w/ Heat Sink #CNE480



Power plant battery pack 4S-6S Li-Po or 12 Cell NiMH

**IMPORTANT: 6 Channel helicopter radio or better with 120° eCCPM mixing required.**

#### Fastener and ball bearing dimensions

Hardware Description and Identification:

M3x6 = 3x6mm and can refer to screws or ball bearings.

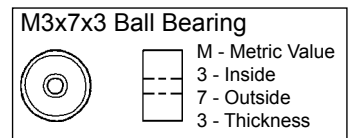
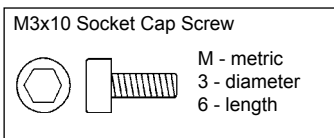
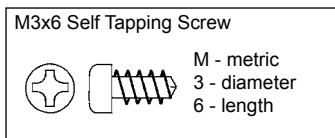
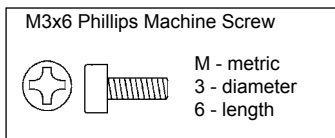

**WARNING: Do not overtighten bolts or screws possibly damaging threads of bolts or components.**

#### Recommended Tools & Accessories

The tools and materials listed below are the minimum needed to build the helicopter:

- Screwdrivers - Slotted and Phillips head
- Long-Nosed Pliers
- Allen Wrenches - 1.5mm, 2.0mm, 2.5mm + 3.0mm
- Appropriate Socket Wrench
- Hobby Scissors
- Double Sided Foam Tape ( 1/16" - 3/32" )
- Foam Rubber ( Radio Packing )
- Thread lock liquid (e.g. Loctite)
- Hobby Grease (Super Lube)
- Oil to lubricate sliding shafts
- CA (Cyanoacrylate) Glue

In addition, the following will make assembly and setup easier, and prove useful later in your model toolbox:

- Part#CN2015 Hardened Tip Hex Screw Driver Set
- Part#CN2026 Pitch Gauge with Paddle Gauge
- Part#CN2034A 15° Curve Tip Ball link Pliers
- Part#CN2052 Main Blade Balancer
- Part#CN2055 Ball Link Sizing Tool
- Part#CN2070 Universal Flybar Lock
- Part#CN2219 Ball Link Easy Driver
- Part#CN2255 Control Rod Gauge
- Part#CNWI26555 5.5mm Nut Driver
- Part#CNWI26570 7.0mm Nut Driver

Hobby scissors #CN2262



Main Blade Pitch Gauge w/Paddle Gauge #CN2026



Loctite #CN2025BS blue #CN2025RS red



Needle Nose Pliers & Cutter Pliers



Lubrication #CN2024T



## 4. Before You Begin

Every attempt has been made to ease the assembly of your kit, at each step where there are complex instructions there are detailed written instructions to walk you through each step. Remember to take a few minutes before each step to carefully examine each process to become familiar with the parts and assembly before beginning that step.

Symbols used to help assist you in building the kit:



Whenever this symbol appears, use CA (cyanoacrylate) glue.



Whenever this symbol appears, use blue thread lock. (CN2025BS)



Whenever this symbol appears, use red thread lock. (CN2025RS)



Whenever this symbol appears, use grease.

## 5. Safety

Before flying, please check to make sure no one else is operating on the same frequency.

Before flight, please check if the batteries or transmitter have enough capacity.

Before turning on the transmitter, please check to ensure the throttle stick is in the lowest position. IDLE switch is Off.

When turning on the unit, please follow the power on/off procedure. Power ON - Turn on the transmitter first and then turn on the receiver. Power OFF - Turn off the receiver first and then turn on the transmitter. If this protocol is not followed, control of the model may be lost.

Before operation, check movement of all controls are smooth and no linkages are binding. Carefully inspect servos for full operation.

Check for missing, damaged, or loose items. Carefully inspect main rotor blades and tail blades for damage. If damaged, replace with new ones to ensure a safe flight.

Check all ball links to ensure proper fitment. If loose, replace ball links with new ones.

Check servo plugs, ESC plugs, motor plugs, gyro plugs, and battery plugs to make sure they are securely fastened. A loose plug may result in a complete lose of control over the model.

Check the tail belt tension to make sure the belt is not too loose. No more than 5mm movement when pushed inward.

# 6. Assembly Instructions

## Main Blade Grip

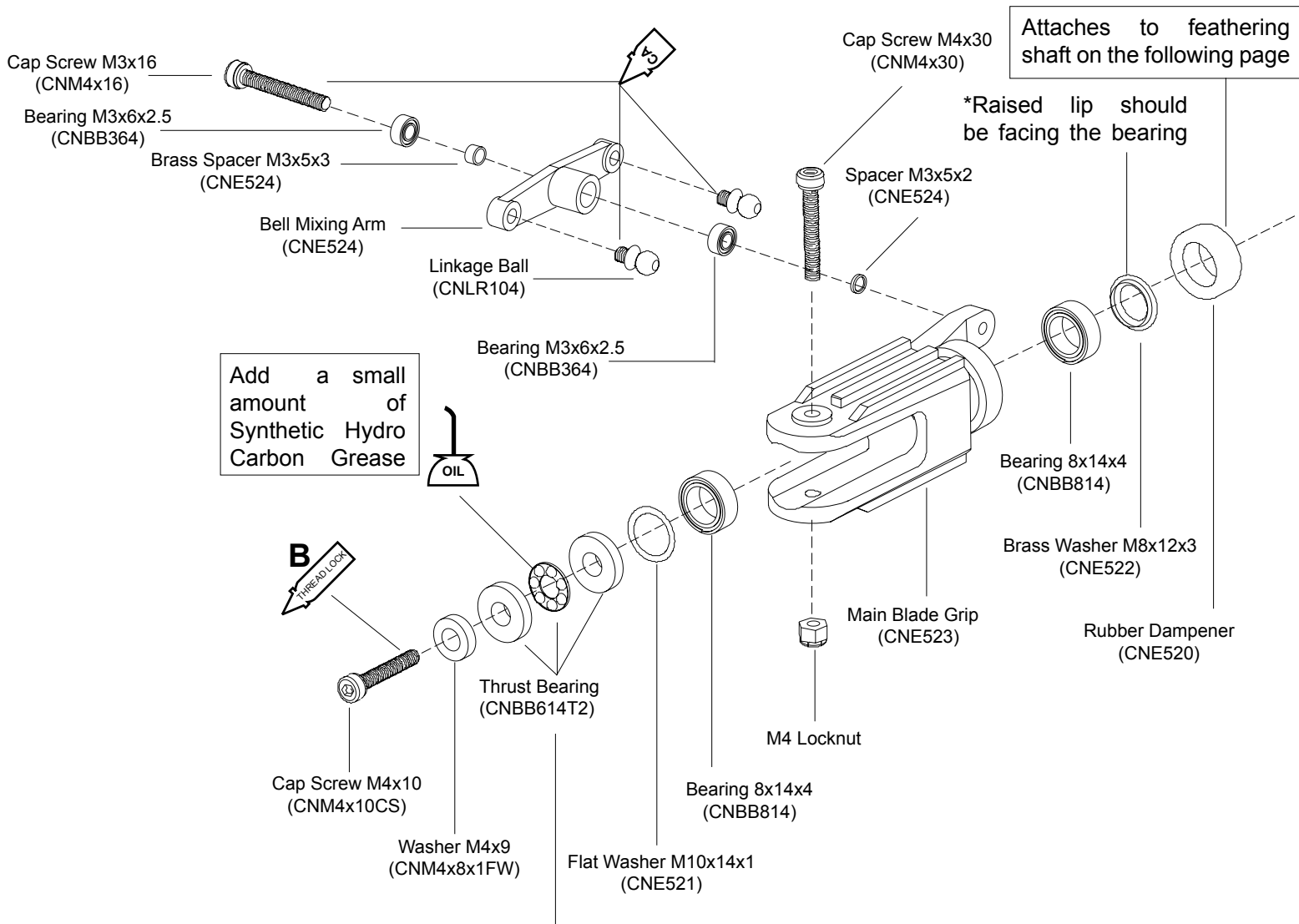

\*The thrust bearing washer with the bigger inner race should be closer to the head block. The thrust bearing washer with the smaller inner race should be closer to the rotor blade.

## Preparing the Flybar Paddles

Wipe the paddles with 70% Isopropyl alcohol making sure that it is free from oil. Use the flybar paddle cover found on the decal sheet. Wrap around the flybar paddle.

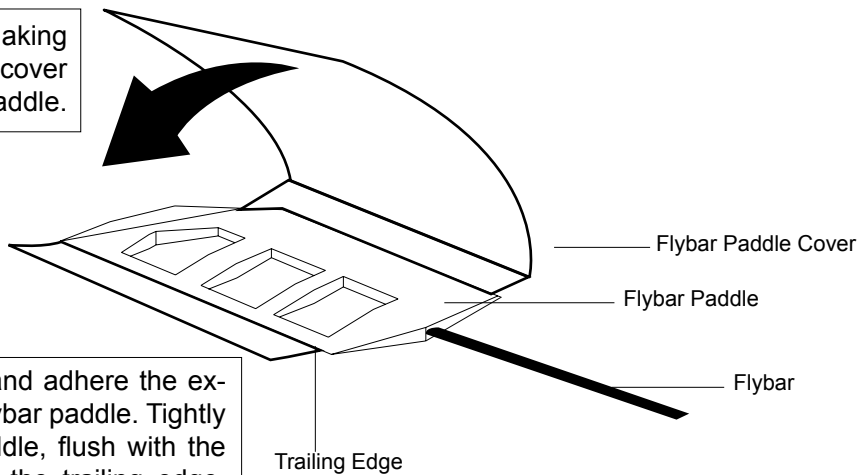

Hint: Cover the bottom end of the flybar paddle and adhere the excess covering material to the trailing edge of the flybar paddle. Tightly pull the top side of the cover over the flybar paddle, flush with the trailing edge and cut the excess material along the trailing edge.

# 6. Assembly Instructions

## Head Block

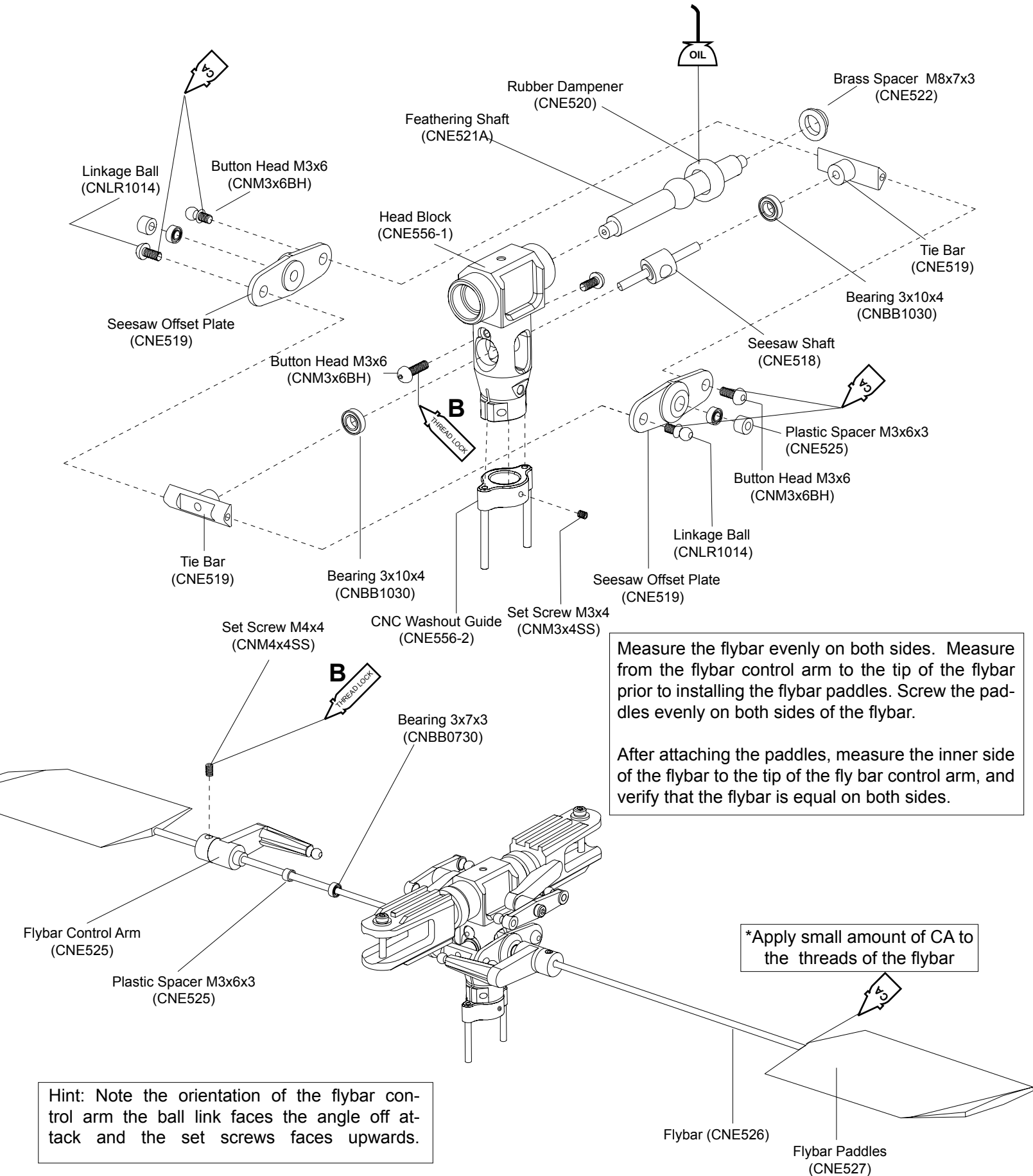

## 6. Assembly Instructions

### Adjusting the Flybar

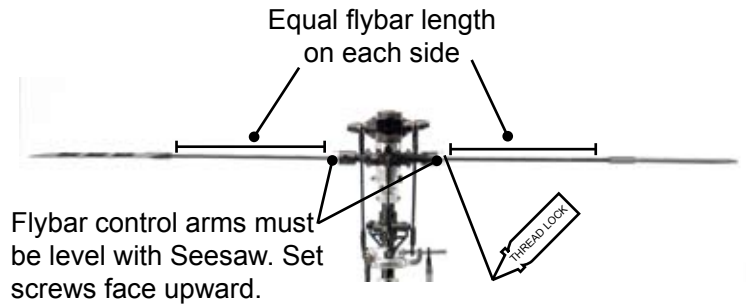
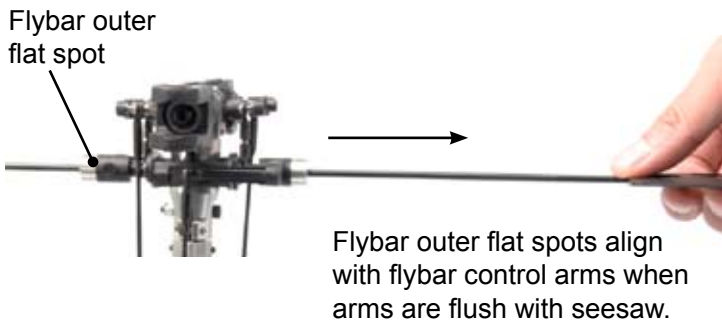

### Swashplate and Washout Assembly

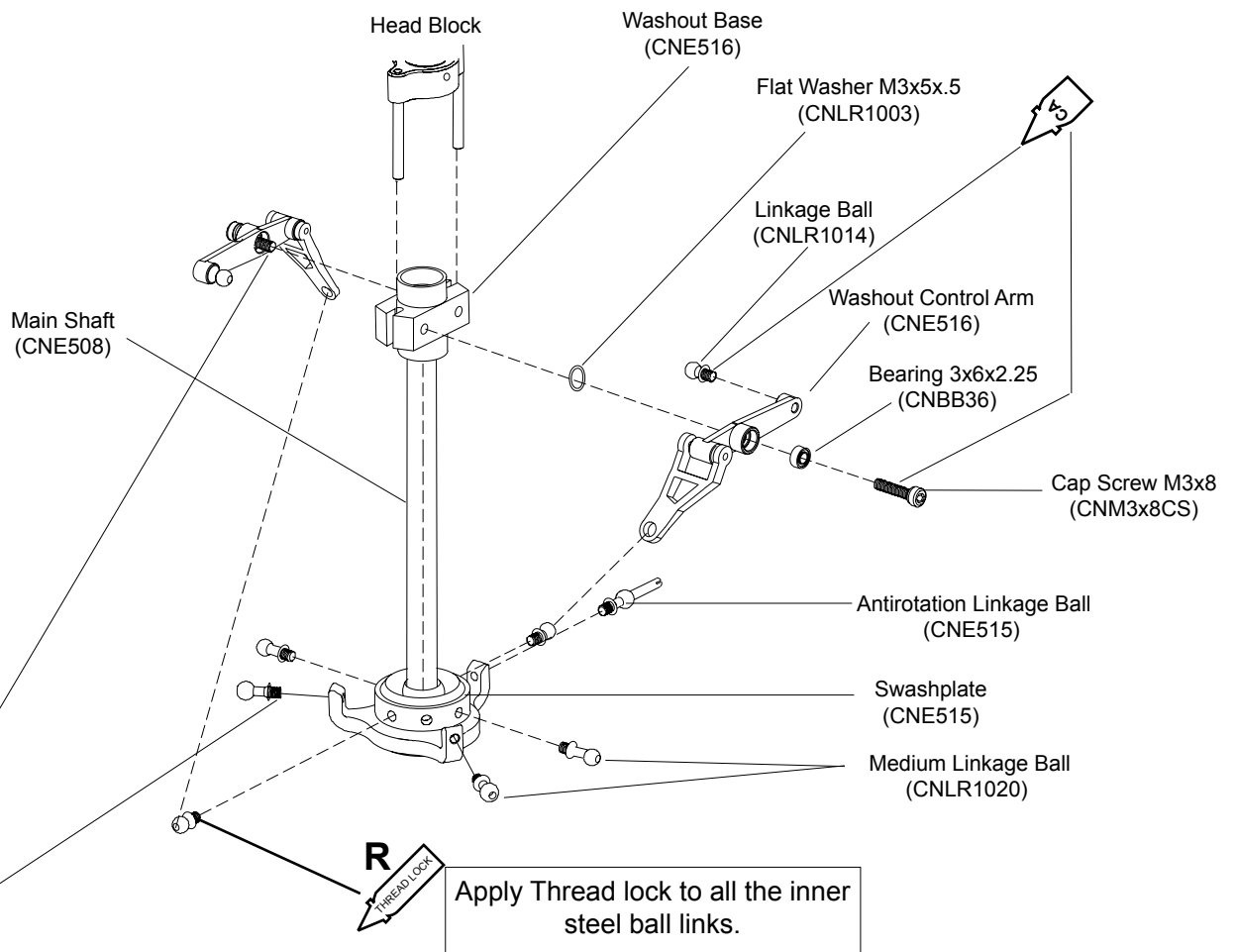

\*Hint: Undo the cap screws and linkage balls to the assembled parts. Apply CA on metal to plastic assembly. Apply blue thread lock on metal to metal assembly. Do not over tighten when screwing the attached assembly to its subassembly.



# 6. Assembly Instructions

## A-Arm Assembly

1. Screw the ball link into the A-arm, make sure it is screwed all the way in. Back it off so that it is parallel with the face of the Arm.

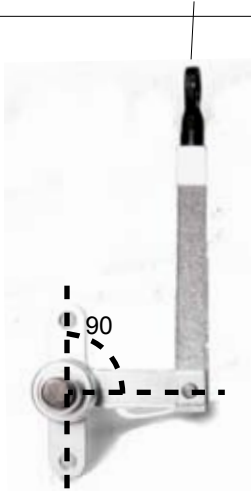

2. Place the elevator push pull bellcrank onto the shaft and the two spacers. Level up the bellcrank so that it is 90 degrees to the A-arm.

3. Use calipers to measure 52mm from one end of the spacer to the other, increase the gap between the bellcrank until this is so. Now double check your 90 degree alignment, and snug all 3 of the set screws, with lock tight.

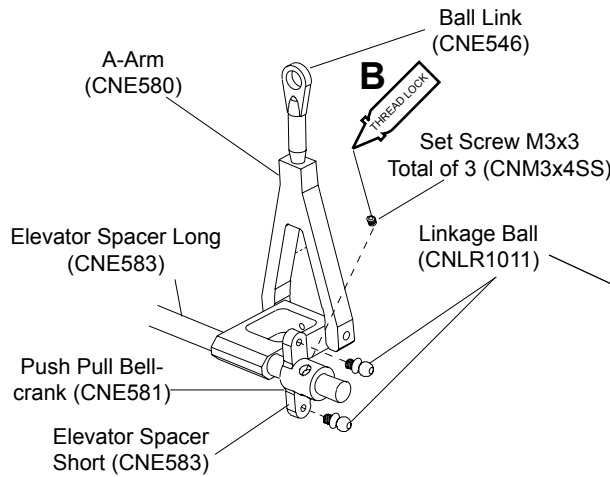
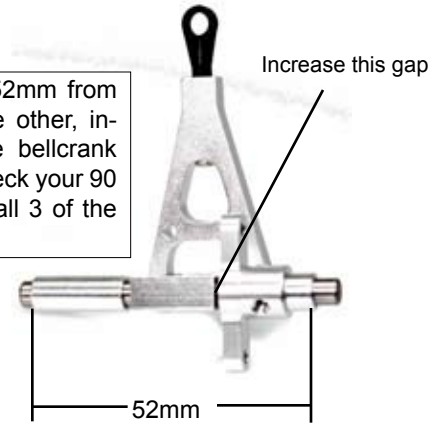

4. Once the set screws are all locked in, screw in the 2 ball links, with blue lock tight.

## Bellcrank Assembly

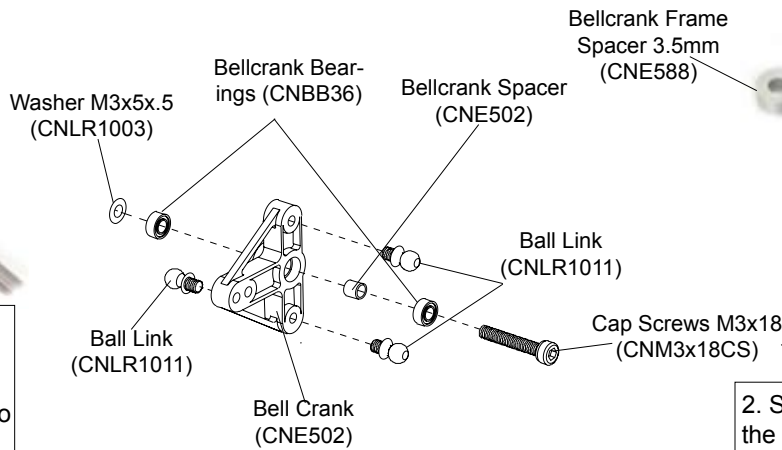

1. The bellcrank is symmetrical. Use thin CA to tightly secure the Ball Links in place as shown. Press the bearings and spacer into the bellcrank, they are a tight fit and do not require CA.

2. Slot the Cap Screw through the bearings and place the small washer



3. Use a M3 Hex Nut to secure the assembled bellcrank through the frames in the hole next to the servo position, Tighten until the bellcrank will spin freely but does not have any slop.

4. Repeat this step for the other side of the frame, remember to install it on the opposite side of the frame.

# 6. Assembly Instructions

## Upper Bearing Block Assembly

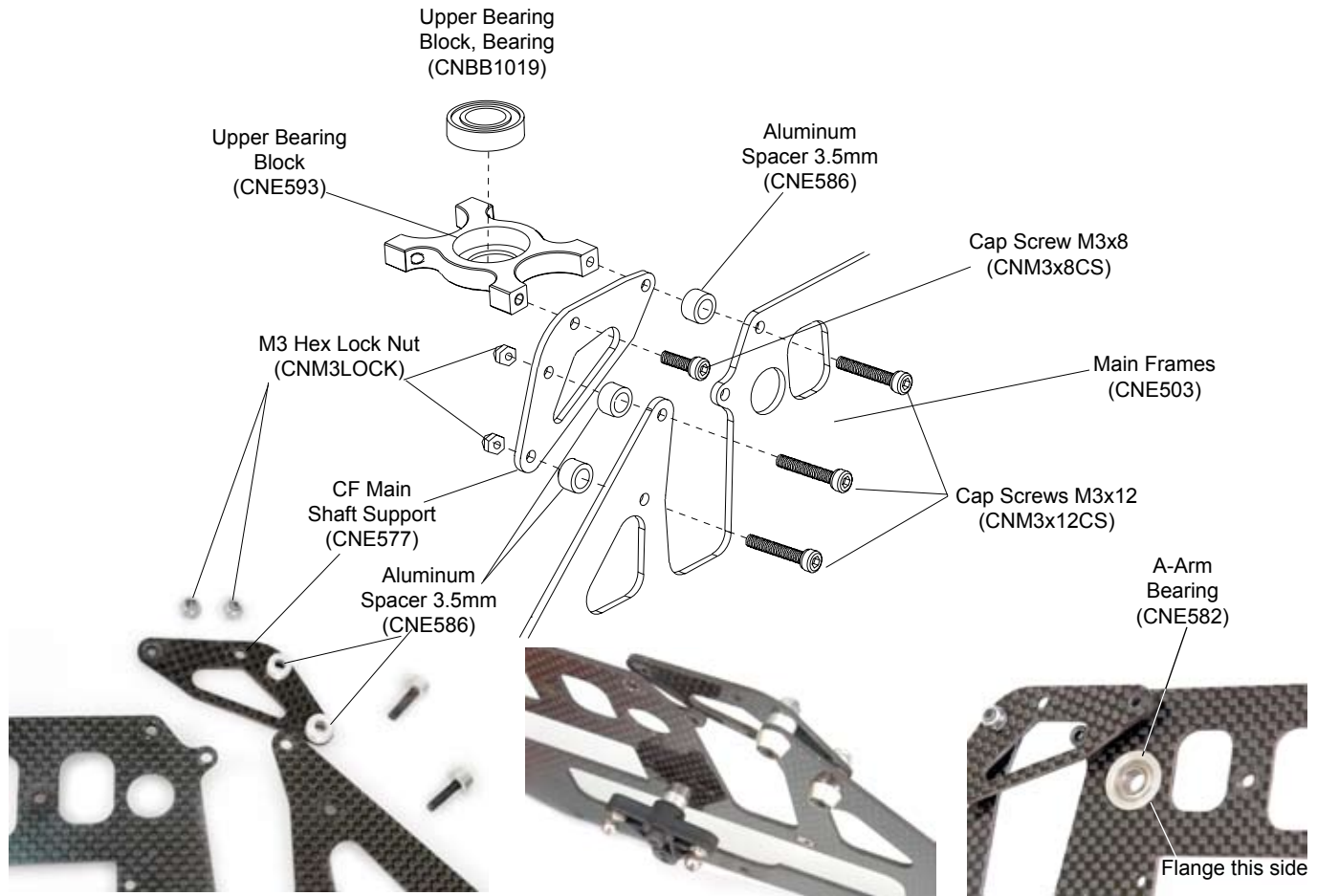

1. Lay down part; CF Main Shaft Support over the holes to ensure correct orientation.

2. Be sure to install the plate on the opposite side to the bellcrank

3. The hole for the A-arm bearing is tight and may require sanding in order for the bearing to fit. Remember to do this in a well ventilated area and use a mask. The bearing should be pushed through from the inside of the frame.

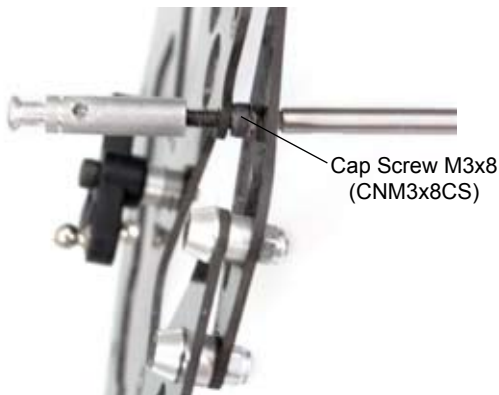

4. Screw the canopy mount through the main frames using a M3x8 Cap Screw.

5. Perform steps 1 to 3 in a mirror fashion to the other side of the frame.



6. Insert the Aluminum spacer between the two carbon pieces. Apply blue lock tight to the cap screws and insert them through the frame into the bearing block. Make sure the bearing is facing up. Do not attach the other side of the frame at this stage.

## 6. Assembly Instructions

### Lower Bearing Block Assembly

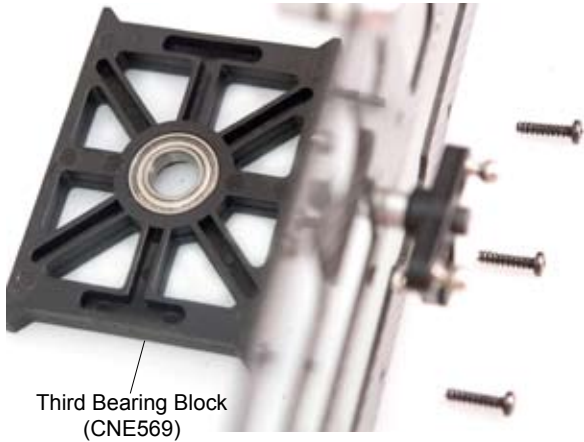

1. Push the bearing (CNBB1019) into the Third Bearing Block (CNE569) and attach to the bottom of the frames, using: Self Tapping Screw M3x10. Make sure your block is facing upwards.

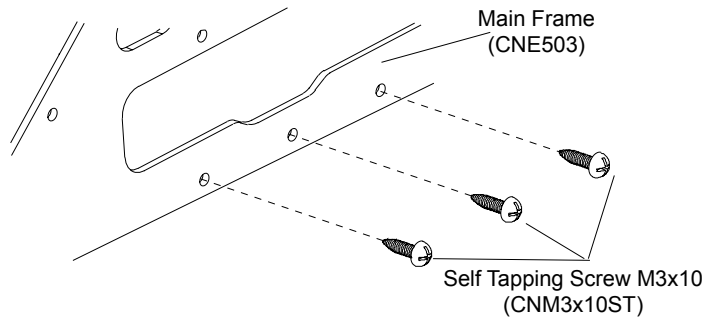

### Motor Mount Assembly



1. Use blue lock tight to install the Motor mount to the inside of the frame. The Motor Mount smooth side must be facing up.

2. Included in your kit is a small piece of sand paper. You may have to sand down the edges of your radio tray and gyro plate in order for them to fit perfectly. When sanding, remove small amounts of material and test fit the parts. You want the parts to fit snugly in place. \*WARNING: Before sanding, make sure you and your model are in a well ventilated area, or outside. When sanding carbon, you must wear a dust mask as inhaling the dust particles can be harmful to your health.\*

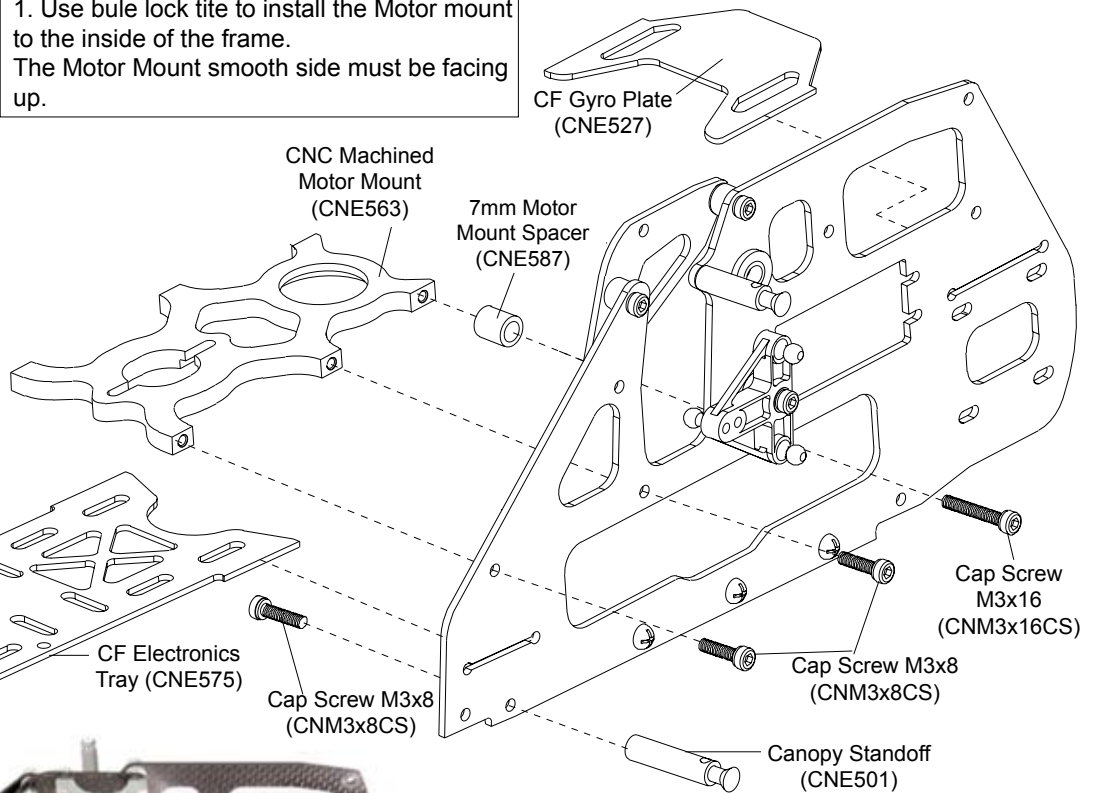

3. Screw in the remaining Canopy Standoff into the main frames, using blue lock tight.

4. Assembly is almost complete, be sure that the opposing frame has the necessary hardware installed.

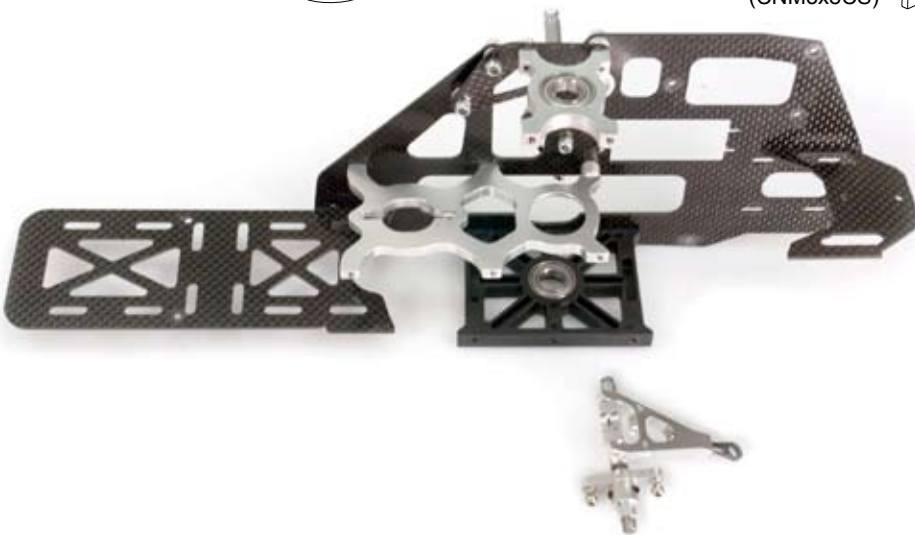

# 6. Assembly Instructions

## Main Frame Assembly

1. Place the two side frames together with the elevator A-arm assembly in-between them.  
When looking through the back the elevator bellcrank should be on the left side.

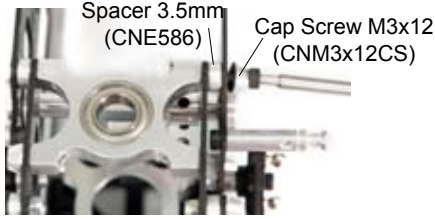

2. First secure the Upper bearing block using a M3x12 cap screw and a M3x8 cap screw, With the Ali-spacer between the carbon frame and the carbon support. Use Blue Locktite.

3. Install the Self tapping screws to secure the bottom.

Button Head Cap Screw M3x8 (CNM3x8BH)

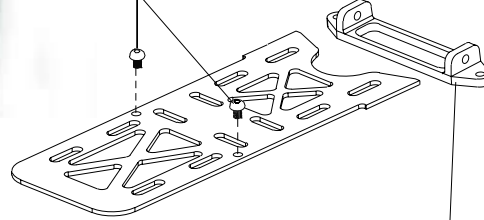

4. Attach the Carbon Switch plate to the two supports, then the supports to the underneath of the CF Radio tray

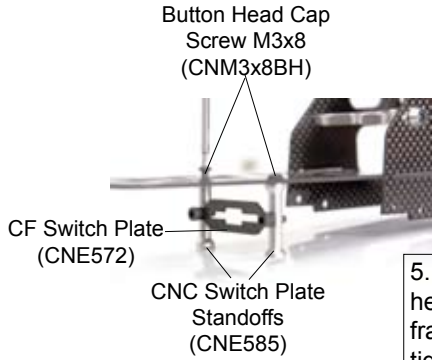
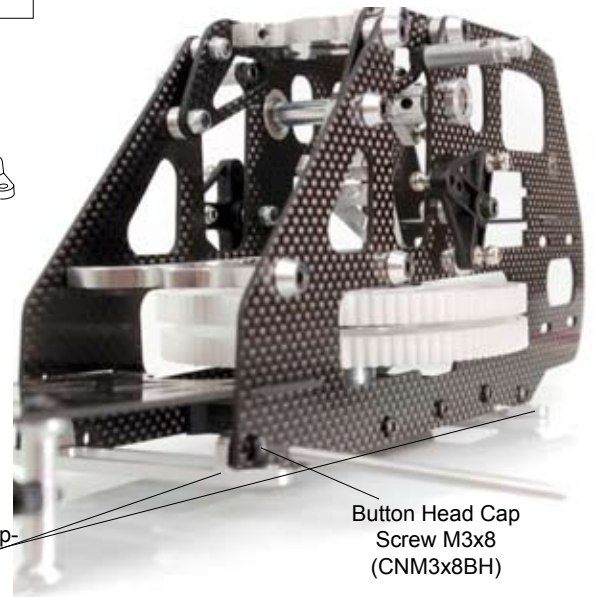

5. Use the remaining four Button head screws to attach the Main frame supports, using blue Lock tight

## Split Gear Assembly

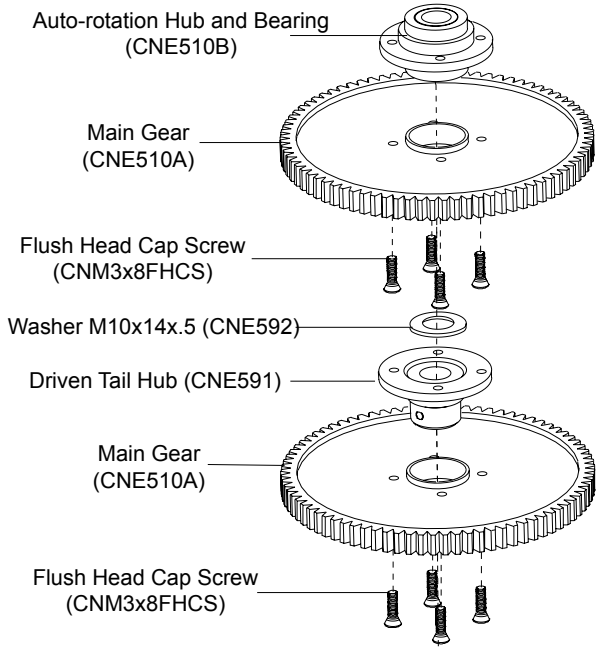

1. Locate which side of your frame assembly has the larger slot for your gear to pass through. Install the first gear inside the frame and push up on the gear until the bearing is fully pressed into the motor mount.

2. Make sure you have the washer on the gear, pass this gear through the slot, this will only be difficult if the top gear is not pushed up far enough. If you continue to have difficulty you can remove the third bearing block.

# 6. Assembly Instructions

## Tail Component Assembly

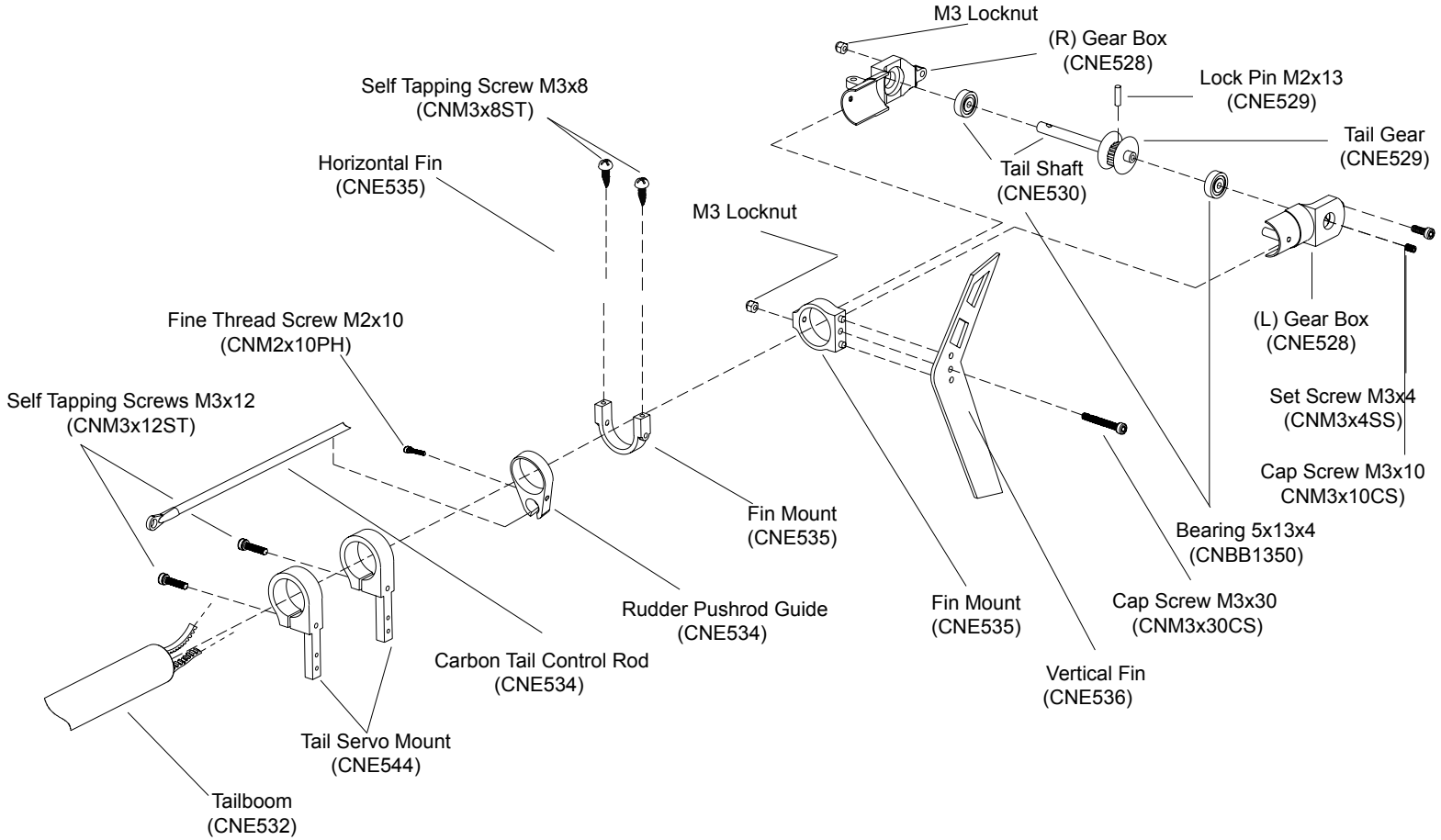

## Tail Boom Support Struts and Rudder Control Rod

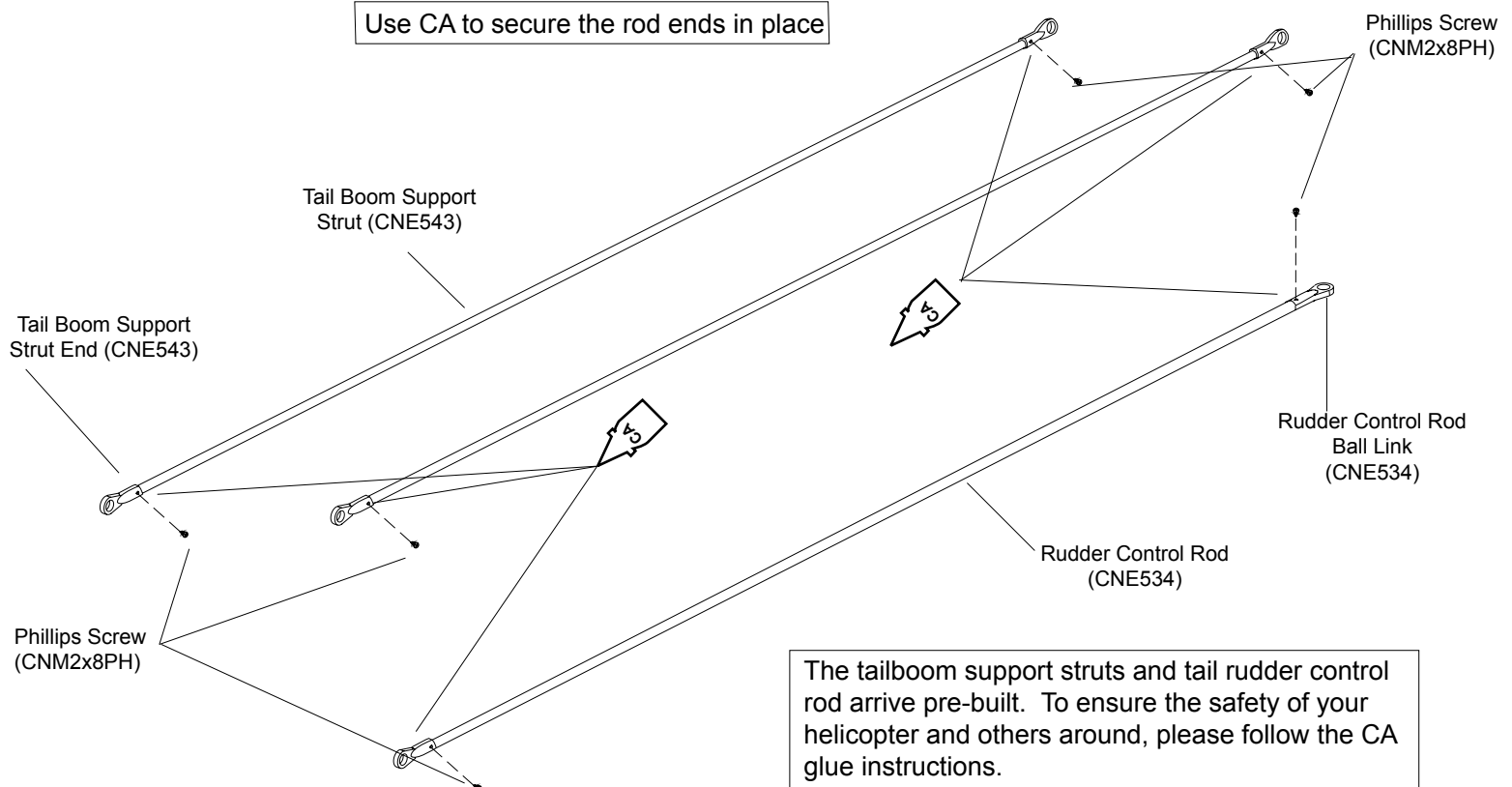

# 6. Assembly Instructions

## Tail Transmission Assembly

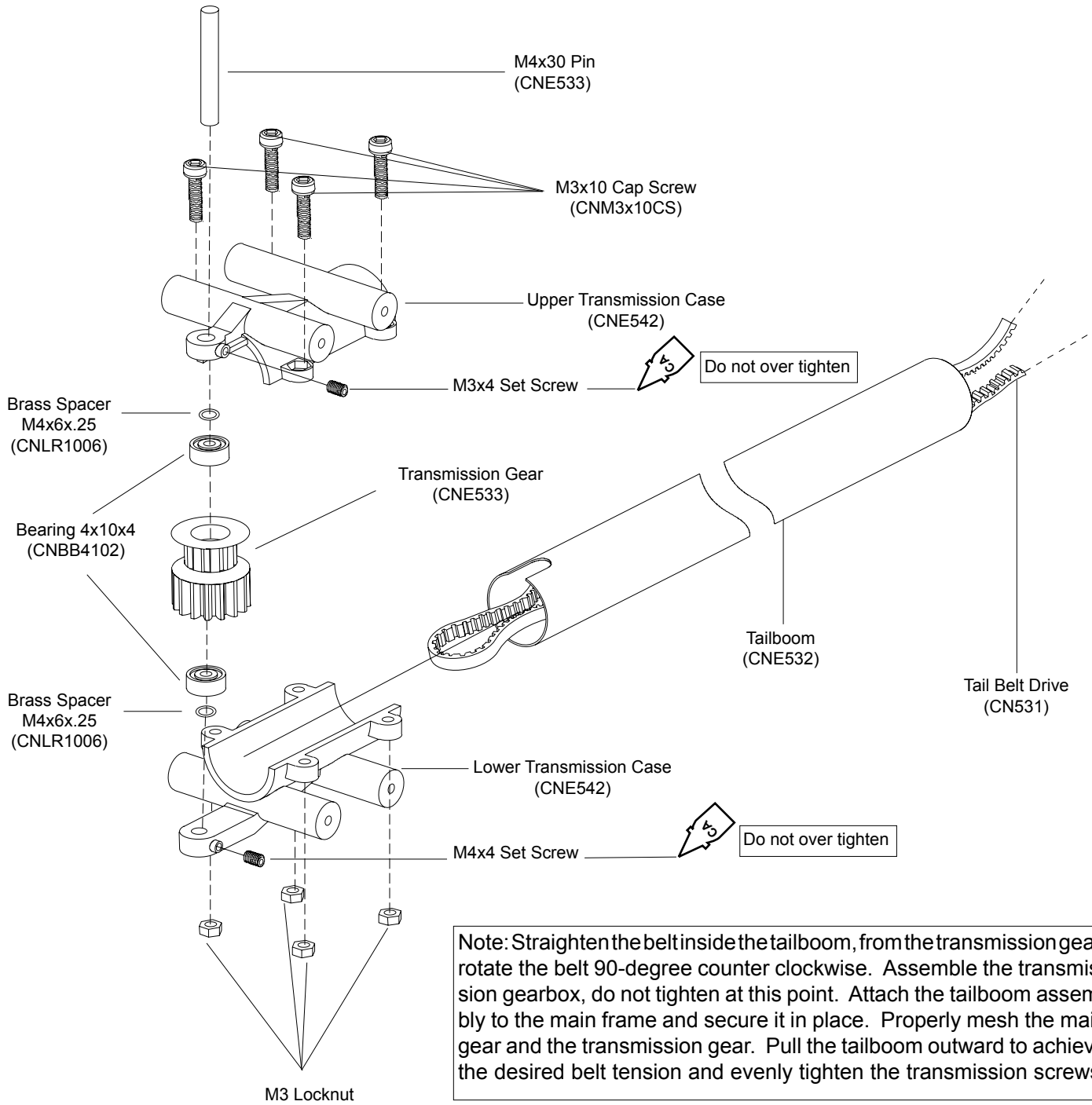

Back of Heli

Tail Drive Belt Direction

Front of Heli

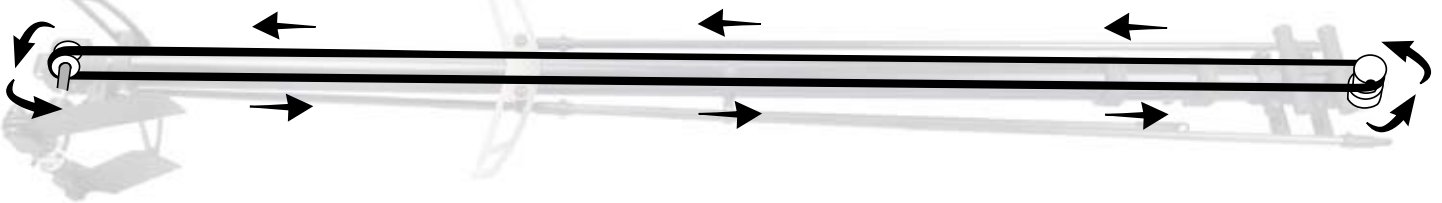

While facing the tail, the tail blades should spin counter clockwise.

# 6. Assembly Instructions

## Tail Gear Box Assembly / Autorotation Hub Assembly

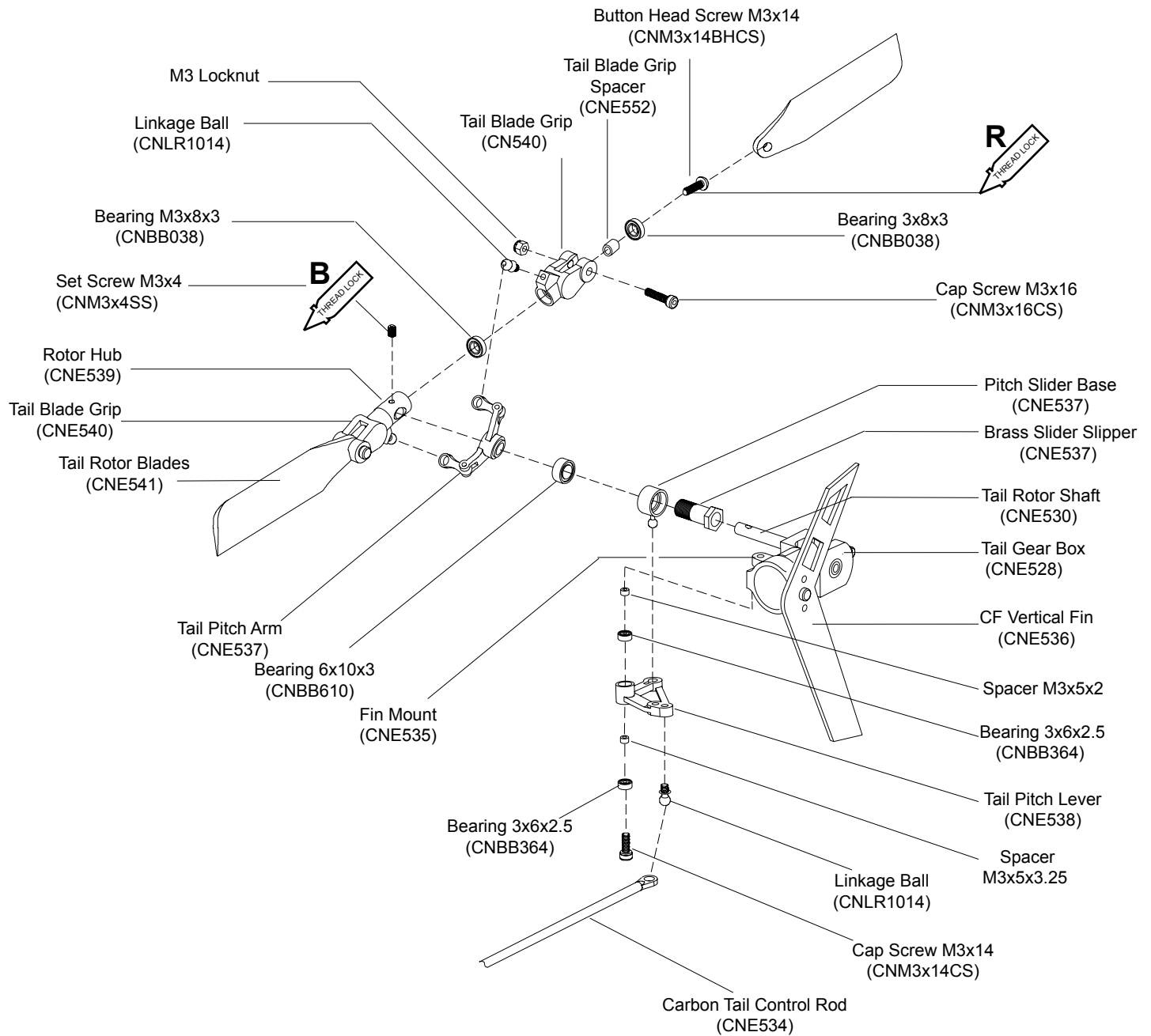

The tail pitch lever will fit, if the lever socket is heated with warm water and ball link pliers are used to pop the ball into the socket. The whole assembly will be nice and free after being put together.

# 6. Assembly Instructions

## Landing Gear Assembly

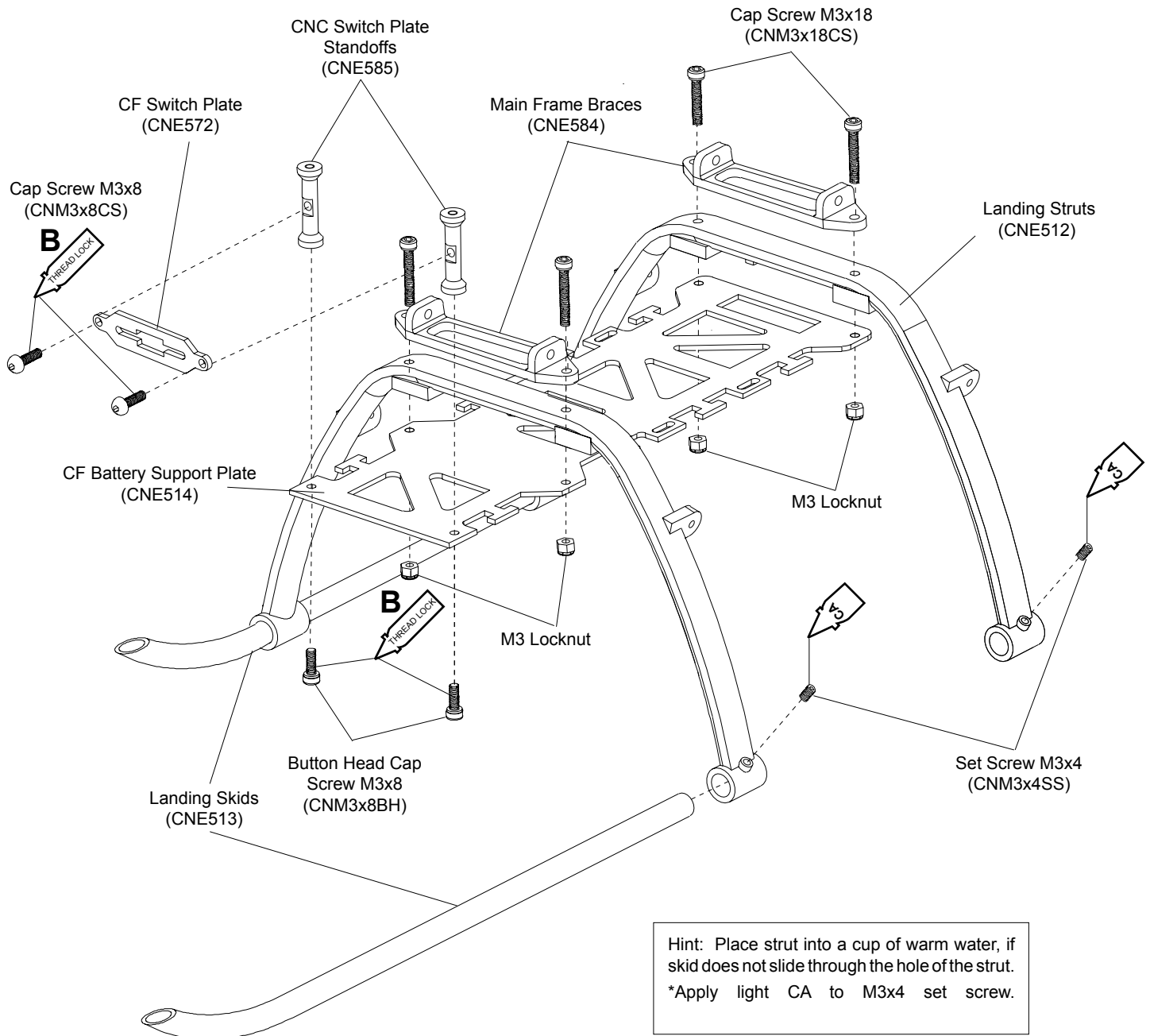

Hint: Place strut into a cup of warm water, if skid does not slide through the hole of the strut.  
\*Apply light CA to M3x4 set screw.



# 7. Putting Together Your Model

## Assembling the Components

After completing the previous steps, the following instructions are for putting together the sub-assemblies. Please follow the instructions and any hints along the way to ensure that you have a properly flying model.



1) Align the mounting posts from the front transmission gearbox with the mounting posts at the rear of the main frame. The horizontal fin on the tail boom facing should face up so the rudder pushrod and tail boom support struts hang below the tail boom.

2) Using the hardware provided attach the tail section to the frame section. **Do not fully tighten the screws till the following step.**

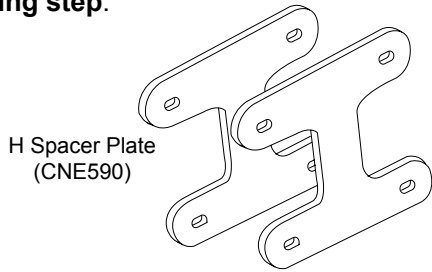

- 1) Place the collar onto the main shaft.
- 2) Place the assembled head through the upper bearing block and down through the gear assembly. Fasten in place with a M3x20 socket head cap screw and Lock Nut.
- 3) Pull up on the head and fasten the set screws into place.

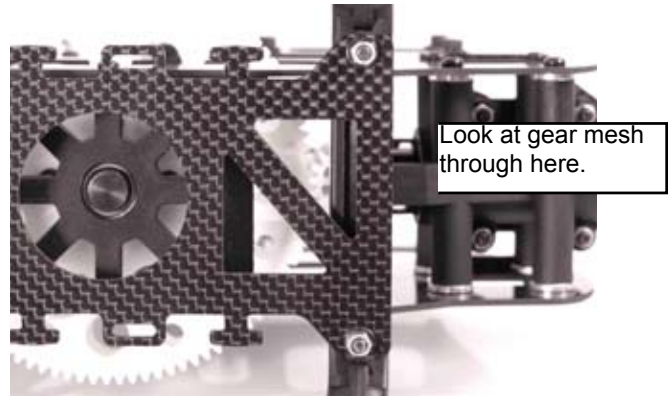

1) Align the transmission gear mesh before fully tightening the screws holding the frame and tail sections. Good alignment is smooth and free of resistance without slipping or skipping teeth. (HINT:) place a strip of paper between the gears to give proper clearance. Turn the main gear while feeding the strip of paper between the gears. If the strip of paper comes out torn, then the gear mesh is too tight. If the strip of paper comes out not matching the obvious accordion pattern from the gears' teeth, then the gear mesh is too loose.

2) Attach the tail boom support struts to the horizontal fin clamp and the rear mounting posts on the landing struts as shown by tightening the four set screws. (HINT:) To help prevent rotation of the horizontal fin mount, wrap the area under the horizontal fin mount with a few layers of electrical tape.

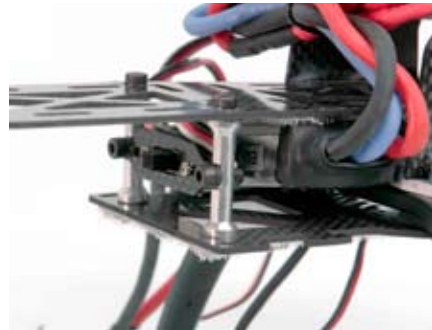

1) Mounting the switch underneath the battery tray keeps it away from moving parts and allows you to access the the switch when the canopy is on. Remember to use locktite on the M3 socket head cap screws.

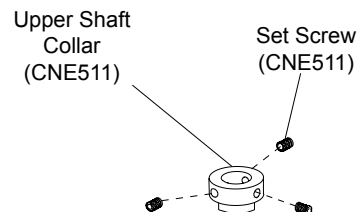

# 7. Putting Together Your Model

## Servo Linkage Lengths

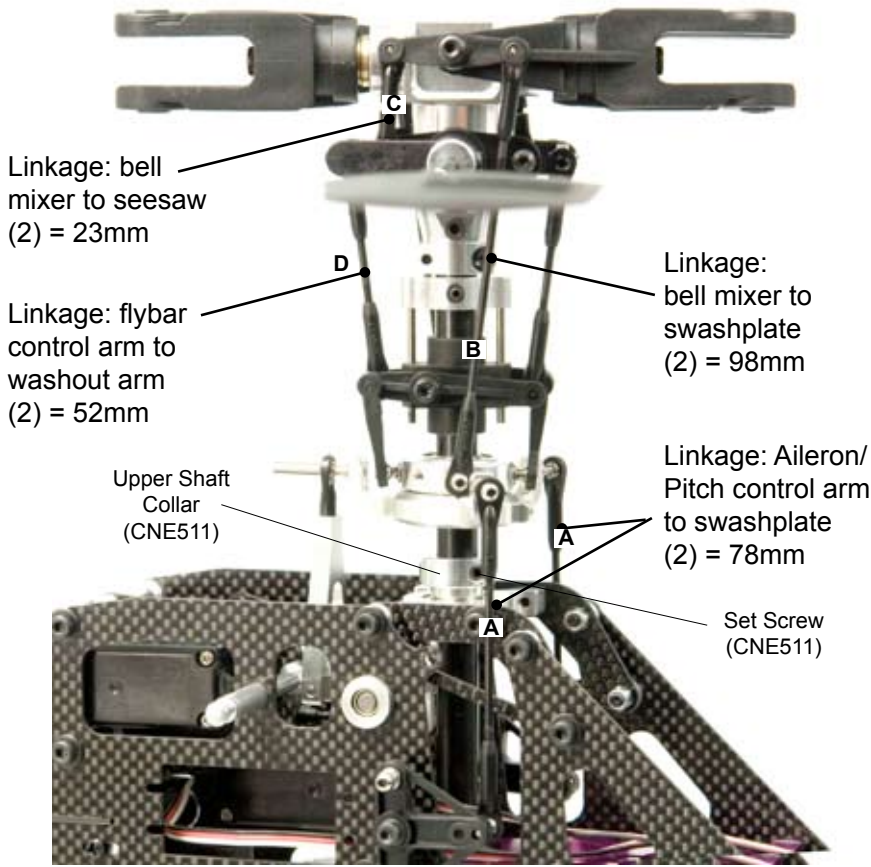

Linkage: bell mixer to seesaw (2) = 23mm

Linkage: flybar control arm to washout arm (2) = 52mm

Linkage: bell mixer to swashplate (2) = 98mm

Linkage: Aileron/Pitch control arm to swashplate (2) = 78mm

Upper Shaft Collar (CNE511)

Set Screw (CNE511)

1) Before proceeding to measure and install the pushrods, make sure you have adjusted the flybar to it's optimal level (flybar paddles flat and parallel to the ground). Adjust the flybar until the outer flat spots align with the set screws in the flybar control arms (set screws facing upward and flybar control arms are flush up against the seesaw).

2) Make certain that the flybar is equal in length on both sides of the rotor head before tightening the flybar control arms. Set the flybar control arms flush and level to the seesaw and **tighten the set screws using locktite.**

It is very important that before you install the pushrod linkages that your transmitter's batteries are fully charged. Then remove all the servo horns from the servos and center all the mechanical or electronic trims on the radio.

Due to the different types of radio and servos that are chosen to install into the helicopter, match each pushrod to the lengths in the table for optimum setup.

**Note: All dimensions are in millimeters and are measured from the centers of the control balls or ball ends.**

**(Optional Part) CN2255 Control Rod Setup Gauge**

Easily duplicates pushrods by attaching a master pushrod and match new pushrods as they are assembled. Gauge has millimeter scale for accurate lengths center to center.

Location	Length	ID
Aileron/Pitch Control Arm to Swashplate	78mm	A
Swashplate to Bell Mixer Link	98mm	B
Bell Mixer to Seesaw	23mm	C
Flybar Control Arm Linkage to Washout Arm	52mm	D

These lengths should allow for approximately +/- 12 degrees of pitch with 0 degrees at center stick (typical 3D setup).

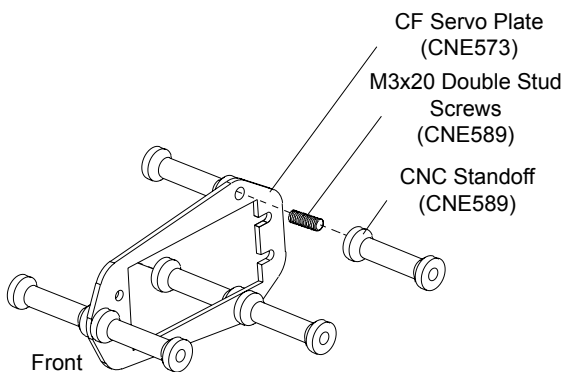

Install your elevator servo so the output or horn is at the front of the Servo Plate.

## 8. Installing and Adjusting Control Components

### Adjusting the Servos

There are three servos that are mounted on the left and right main frames. They work together to tilt the swashplate producing the collective pitch, roll cyclic pitch (aileron control) and the fore-aft cyclic pitch (elevator control). Before beginning this section you should center all servos using the radio. All servo arms must be set with linkages as pictured at 90 degree angles. **All servos mount with M2.5x12 self tapping screws, M2 servo balls and M2 Nuts.** IMPORTANT: Century logo on all ball links must face OUTWARD as pictured.

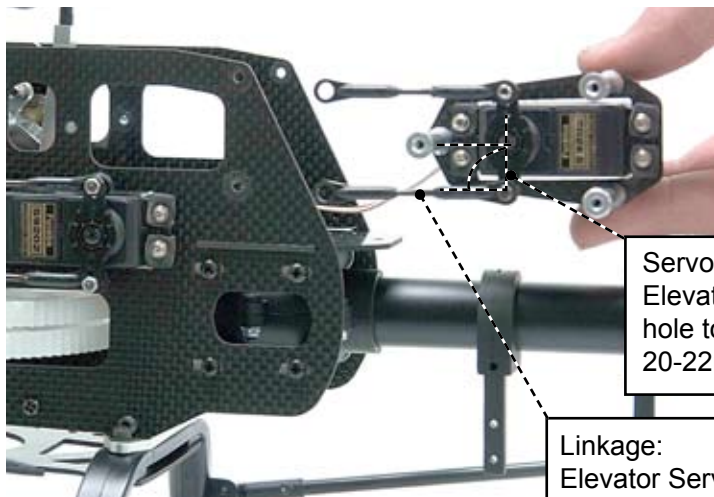

Servo Arm:  
Elevator Servo  
hole to hole =  
20-22mm

Linkage:  
Elevator Servo  
to bellcrank (2)  
=47mm

Century logo on all ball links must face OUTWARD as pictured

Use the 4 servo screws and 2 servo mounting tabs to mount the elevator servo with the servo arm output facing toward the front inside of the frame (pictured above). The distance from the center of the servo to the center of the ball on the servo arm should be between 20-22mm

Place one servo ball to the pitch servo arm facing inside toward the frame. Attach two 50mm linkage to the servo arm ball then to the balls on the elevator bellcrank (CNE581).

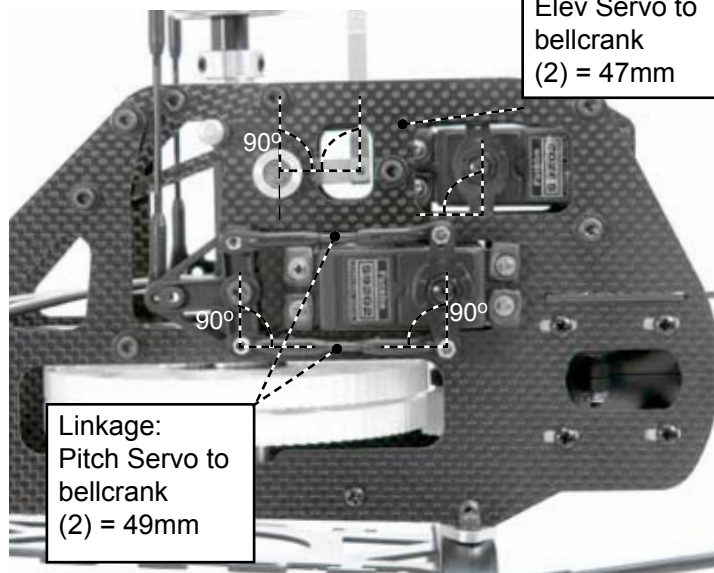

Linkage:  
Elev Servo to  
bellcrank  
(2) = 47mm

Linkage:  
Pitch Servo to  
bellcrank  
(2) = 49mm

The pitch servo will mount with a full servo arm on the lower opening of the left side of the main frame. The distance between the steel balls (center of ball) on the servo arm should be 25mm. Use the 4 servo screws and 2 servo mounting tabs to mount the pitch servo with the servo arm further toward the rear of the frame (pictured above).

Place two servo balls on to the pitch servo arm facing inside toward the frame. Attach 2 of the 49mm linkages to the servo arm balls then to the balls on the pitch bellcrank.

The aileron servo will mount with a full servo arm on the lower opening of the right side of the main frame. The distance between the steel balls (center of ball) on the servo arm should be 12.5mm. Use the 4 servo screws and 2 servo mounting tabs to mount the aileron servo with the servo arm further toward the rear of the frame (pictured above).

Place two servo balls to the aileron servo arm facing inside toward the frame. Attach 2 of the 49mm linkages to the servo arm balls then to the balls on the aileron bellcrank.

Move the collective stick to its maximum position and watch for any roll (aileron) or pitch (elevator) inputs. If an input is found, the problem will be one of the following in the table. The table describes the symptom and the steps to correct them.



Linkage:  
Elevator Servo  
to bellcrank(2)  
= 50mm

Elevator Bellcrank needs to be pushed up against bearing (CNE582).

# 8. Installing and Adjusting Control Components

## CCPM Servo Guidelines

The goal in the end after all the servos are mounted is to have the swashplate sit level or at 90 degrees to the main shaft and have the swashplate move equally fore, aft and side to side. The swashplate will also travel up and down as the three servos work together. This will result if the previous instructions have been followed and the ATV function for the three CCPM servos has been set very, very accurately to eliminate pitch change when moving the aileron or elevator sticks.

**View: Left Side**

Swashplate is aligned 90° with main shaft

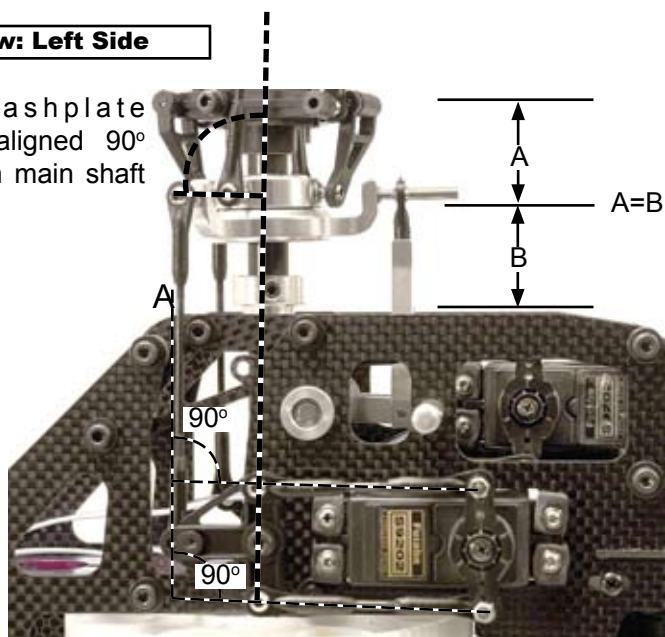

After installing the three cyclic pushrods, the swashplate should sit level.

Move the collective stick to its maximum position and watch for any roll (aileron) or pitch (elevator) inputs. If an input is found, the problem will be one of the following in the table. The table describes the symptom and the steps to correct them.

Symptom	Corrective Solution
metal control ball distance	move ball location to match other servos, or carefully use ATV
angle of horn & servo not 90°	set radio to 0%, place horn on, if not 90, take off and turn until it is.
angle of horn & linkage not 90°	adjust pushrod until set exactly parallel to bellcrank/
swashplate is not level	adjust pushrod A length to level

## Setting Up the Rudder Servo

The Rudder Servo Pushrod changes the pitch of the tail rotor blades to increase or decrease the torque compensation to rotate the nose of the helicopter about the main shaft.

Use a servo horn in the shape of a cross and trim the 3 of the 4 arms off. The Rudder Servo Pushrod has a preset length from the factory. Use the 4 Servo screws and 2 servo mounting tabs to mount the servo with the servo output facing the forward right side of the helicopter (pictured to the right). At this point, turn on your radio equipment to center the rudder servo. Attach the servo horn at 90 degrees aligned with the servo.

Use a servo ball on the outside of the servo arm. Attach the front end of the rudder control rod to the servo ball.

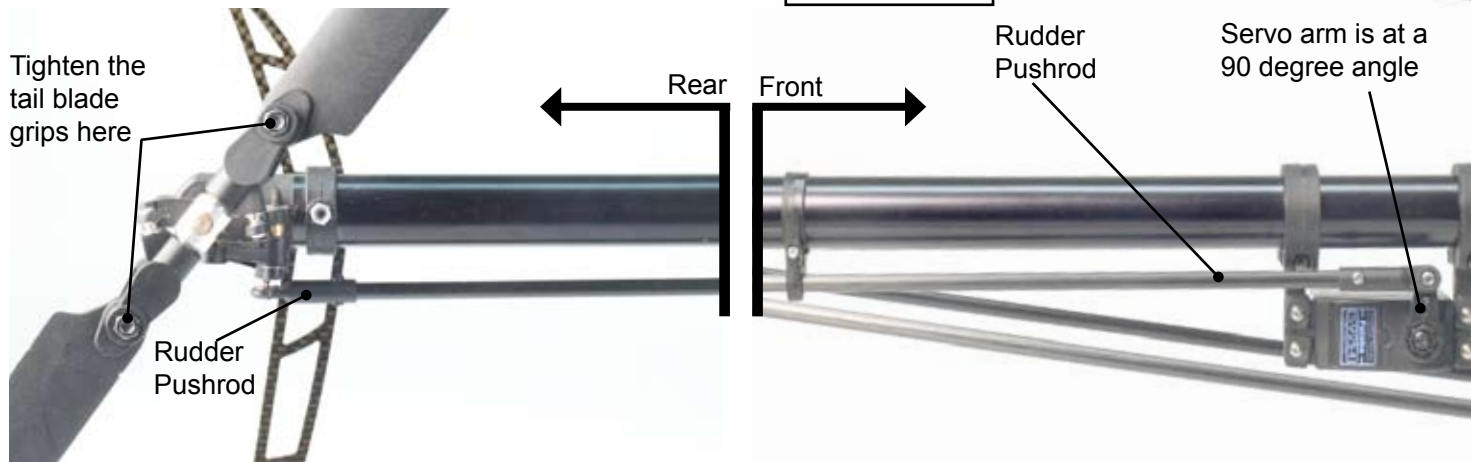
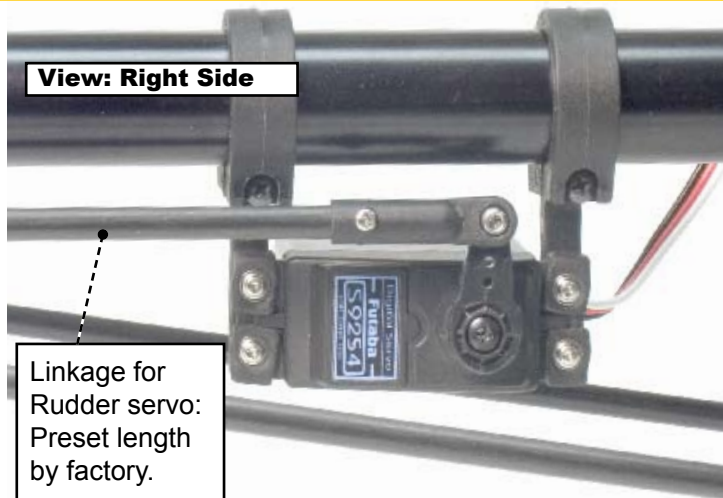

## 8. Installing and Adjusting Control Components

### Setting Tail Rudder Pushrod & Blades

- 1) When setting up the pitch of the tail blades, the tail pitch plate should be first set in the middle position of the tail rotor shaft. The tail blades should have no pitch in that position. Tighten the tail rotor blades until the blade grips hold firm yet soft enough so that the tail blades can still fold back in the event of a blade strike.
- 2) Adjust the position of the rudder servo bracket so that the tail pitch plate is centered on the tail rotor shaft while the servo arm is at a 90 degree angle.

#### Hint: Setting zero pitch for tail blades



Tail rotor blades with zero pitch (blade tips will be in-line)

As the rudder stick is moved to the right, the rudder pushrod will move forward increasing the thrust in the tail blades rotating the nose to the right.

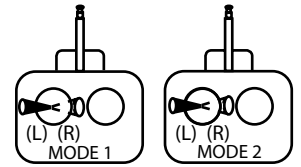

Tail blades will line up in a flat straight line



### Mounting Motor and Electronics

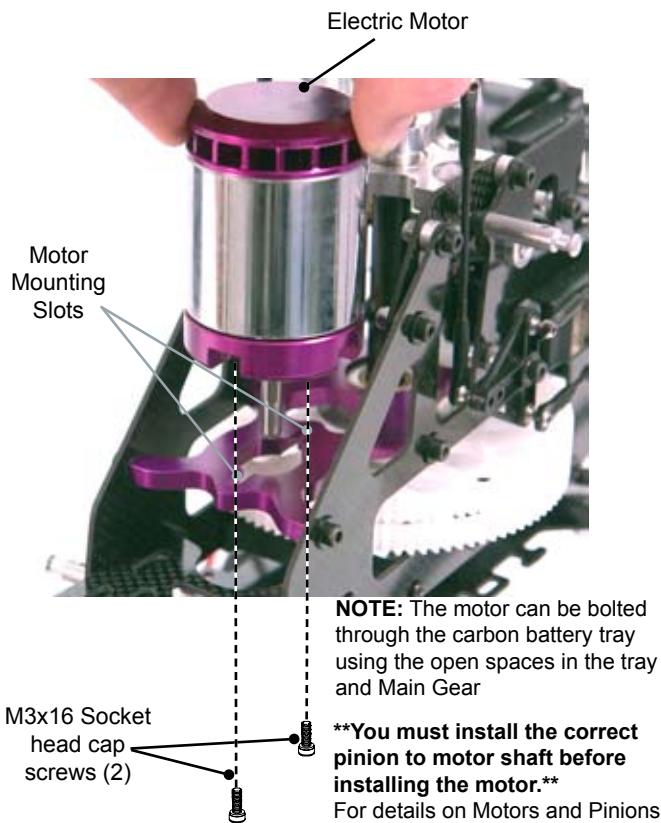

(1) Dry fit the pinion gear to the main motor prior to mounting. Make sure the main motor gear rides in line with the main gear on the Swift. The key to installing the motor is the gear mesh. The elongated slots for mounting the motor allow space to adjust the mesh between the motor pinion gear and the main gear. Install the motor to the motor mounting plate and secure with hardware provided by the manufacturer of the motor.

(2) Install the batteries and control system neatly onto the electronics tray. When installing electronics make sure that wires are not going to come into contact with moving parts. Use foam rubber wrap to wrap the receiver. **\*\* The actual arranged components may be different than the picture illustrates.**

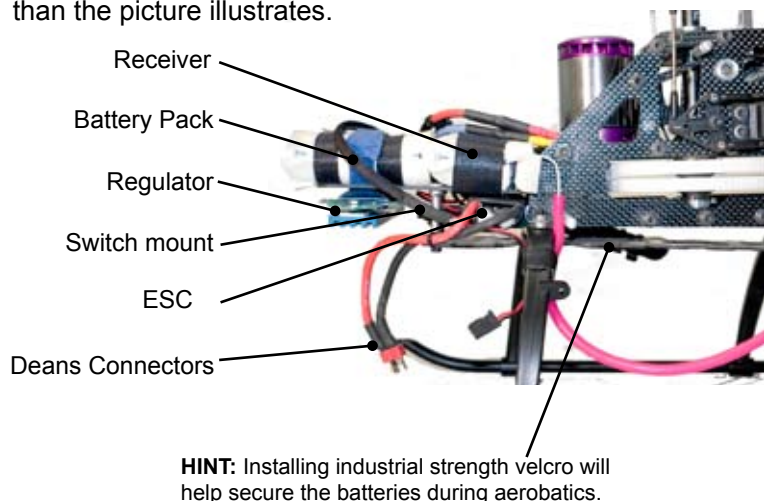

## 9. Final Preparations

### Mounting the Gyro

The built in Gyro Mounting Plate can be used to mount the gyro at the rear of the helicopter. It is extremely important that the gyro is attached using only the supplied two sided tape onto a clean flat surface. Keep all wires and components away from the gyro housing. Do not use straps or elastics to secure the gyro.

Install the gyro using double sided foam tape ( supplied with gyro ) put a full strip along the bottom of the gyro unit and press onto the surface. For a good bond make sure both surfaces are clean and dry.



### Preparing the Canopy

Cut the windshield of the canopy to align with the windshield lip of the canopy. Use the supplied hardware to attach the windshield to the canopy. **(HINT:)** Use Krylon 'Fusion' paint if attempting to paint.

**Make sure the canopy's surface is free from oils prior to applying the decals.** Decals are designed for application as pictured. Mount the decals in such a way that they do not come too close to the canopy mounting grommets.

Mount the canopy to the front of the helicopter using the four grommet posts as shown. Be sure that the rotor head linkage is not obstructed and the swashplate has room to move.



The canopy may require cutting to make space for certain batteries or other extras. We recommend the use of a dremel. A face mask and goggles should be used when cutting fiberglass



### Preparing, Mounting & Tracking The Main Rotor Blades

The Main Rotor Blades are not included in Swift Carbon 550 kit. Please refer to your blades instructions for proper care and storage of your blades. In the event of a crash-landing, discard rotor blades. Scuffs or marks on the blade tips may be the only visible damage however there is no method for inspecting the internal structure of the rotor blades for stress cracks which can cause total blade failure at an unpredictable time. Also, do not store rotor blades indoors in direct sunlight or near heat sources for any period of time. Simply wipe blades clean after each flight.

Blades rotate clockwise, so observe the leading edge. To install the blades, slide the root into the rotor grip and insert one 4mm x 30 Shouldered Socket Cap Screw through the top grip and secure using one 4mm Locknut. Repeat for opposite rotor blade. Blade bolt tension will affect how the blades perform. To set proper tension, start from loose blades (bolt is loose enough for the blade to pivot freely from the grip) and tighten the bolts a little at a time until the blades will hold straight as the helicopter is tipped on its side. Slightly tighter is good. Too tight and a vibration will occur, too loose and a tail boom strike can happen. Tail blades can be set the same way.

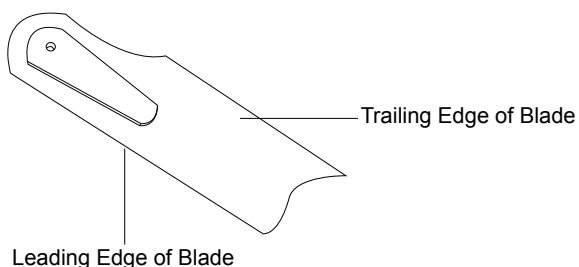

For aerobatic/stunt flight, the Swift Carbon 550 flies best using symmetrical rotor blades. For your convenience you can also use semi-symmetrical for smooth aerobatics and scale flying.

#### Recommended High Performance Rotorblades Main & Tail

CN265166C	Rotortech Carbon 515mm Main Blades
CN265501	Rotortech Carbon 550mm Main Blades
CN265666	Rotortech Carbon 560mm SG 3D Blades
CN260762	Rotortech Carbon 75mm Tail Blades
CN25080	Carbon 80mm Tail Blades

## 9. Final Preparations

### Preparing, Mounting & Tracking The Main Rotor Blades

(1) The Swift Carbon 550 does not come with main rotor blades. Please refer to the instructions included with your blades (must be purchased separately and are not included with the Swift Carbon 550 kit).

(2) Use the 2 M4x30 blade bolts and M4 locknuts to secure the blades to the blade grips on the main rotor head. Main rotor blades should have their leading edge turning clockwise.

**IMPORTANT NOTE: MAIN BLADES AND FLYBAR PADDLES TURN CLOCKWISE.**

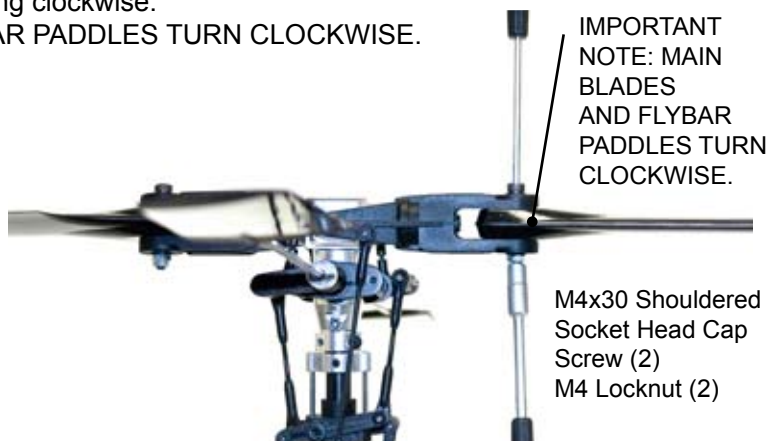

Balance is the most important part in maintaining a safe and reliable helicopter. First check the blades for balance, this can be done on a blade balancer.

(Optional Item) CN2052 Accuratech Main Blade Balancer.

### Tracking Adjustment

(3) Tracking refers to trimming the actual pitch of the main rotor blades to be equal. On the first flight, bring the rotor head up to speed without leaving the ground and look at the side or profile of the rotor disk (FROM A VERY SAFE DISTANCE, MAKING SURE TO WEAR EYE PROTECTION).

(4) Only one rotor blade should be visible, if there are two distinctive blades then the tracking linkage must be changed. Observe which blade is tracking above the other by marking one first. Track that blade lower by shortening the 'bell mixer to swashplate' linkage rod.



**ASSEMBLY COMPLETE! MODELER IS RESPONSIBLE FOR COMPLETENESS AND SAFETY OF THE MODEL.**

# 10. Setup and Adjustment

## Final Adjustments - Radio Setup

Now that the servo installation into the helicopter is finished the following pages should be reviewed. As various types of radios can be used to setup the helicopter, some of the following information may not apply.

### Servo Direction (Servo Reversing)

Check that all servos move in the correct directions.

### Dual Rates

For beginners (using flybar weights, or optional beginner paddles Part #HI3179) the dual rate values should be set as follows:

Normal position: (high rate) 100%  
Switch position 1: (low rate) 75%

### Exponential

The exponential function allows adjustment of how sensitive the cyclic controls are when the machine is hovering. It is recommended that a negative amount of expo is applied to make the heli more precise in the hover.

### Pitch & Throttle Curve Adjustments

With today's speed controllers with built in governors, it is recommended that you always fly in idle up with a flat throttle curve at about 90%

### Pitch Curve Adjustment

The following chart shows the values for the collective pitch measured in degrees which are made on the helicopter using a pitch gauge. The Travel Adjustment function (if available makes these settings easy).

For the beginner it is recommended to set the low stick position to 0 degrees to avoid damaging the helicopter while reducing the power during the first few flights. These settings will need slight adjustments to keep the helicopter at a consistent height at mid stick.

Pitch Curve Values by Degrees

Flight Mode	Setup Method	Low Pitch (Low Stick)	Hovering (Mid Stick)	High Pitch (High Stick)
N	Beginner	-5	0	10
1	Stunt & Aerobatics	-7	0	10
2	3D**	-10	0	10
H	Auto-rotation	-11	0	11

( N - Normal flight mode, 1 - Stunt mode one, 2 - Stunt mode two, H - Throttle hold-autorotation )

## Setting up eCCPM

### General guideline in setting up eCCPM

1. Power up radio and center both sticks. (Tip: add a point above and below the center point of the pitch curve and change them to 50% to widen the "center and zero" portion of the pitch curve for easier reference BUT BE SURE TO REMOVE THEM BEFORE FLIGHT )
2. Place servo horns on all 3 cyclic/pitch servo's as close to 90° to the pushrod as possible.
3. Using a square, straightedge, or other means use the radio SUBTRIM to fine tune servo positions to ensure they are exactly 90° to the pushrod. Once the subtrims are set, do not adjust them again as this is the reference neutral position.
4. Now align the swash to be perfectly centered and leveled on the mainshaft (left/right and fore/aft tilt) using a swash leveling tool or something similar. If it is off fore/aft or left/right adjust the swash pushrods accordingly but DO NOT adjust subtrim.
5. Once the swash is perfectly centered/leveled at mid stick it is time to set END POINTS/ATV's.
6. Move the stick to full collective and again check to see if the swash is perfectly leveled. If it is not adjust the end points of the specific servo that is offering too much or too little travel (tip: leave the elevator servo at 100% both directions and adjust just the pitch/ail servo's to keep a reference center). The adjustment amounts should not exceed 6-7% or you may have different sized arm lengths on the servo's.
7. Move the stick to low collective and again check to see that it is perfectly leveled. If it is not adjust the end point of the specific servo that is offering too much or too little travel.
- 8: Go back and remove the two extra points from the pitch curve from Step 1.

If you need to trim your heli for neutral flight do so with the trim sliders but DO NOT ADJUST SUBTRIMS.

You can now fine tune any interaction by doing the following:

1. Trim the heli for neutral hovering.
2. Do a few full collective climb outs and note if the heli pitches fore/aft or left/right.

If there were pitch changes note the direction and go back to the ATV screen to fine tune the cyclic servo travel. (example: Heli pitches back when full collective is applied, either add a few percent to the full stick elevator travel or reduce both aileron/pitch servo travel) Only change a few percent at a time and do several climb outs before adjustments to ensure it is not environmental changes causing the pitch changes.

- 3: Do a few full negative inverted climb out and note the same as above. Make adjustments on the LOW stick side instead of HIGH stick side.



# 11. Final Preparations

## Final Adjustments - Tail Rotor Setup

What separates airplane radio equipment from the helicopter version is in the control of the individual curves discussed earlier and in the Revo-mixing\*.

Take a moment to consider the helicopter hovering in front of you.

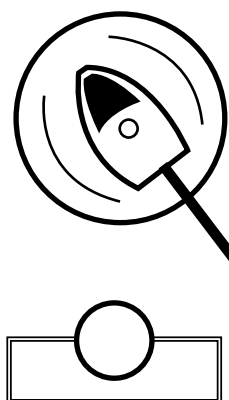

### 1 Nose rotates left at hover

**Problem:** Not enough pitch in tail rotor to match torque setting of motor.

**Action:** Increase pitch by shortening the rudder push-rod.

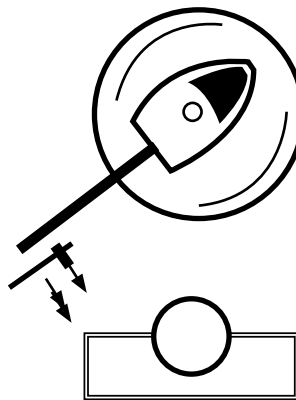

### 2 Nose rotates right at hover

**Problem:** Too much pitch in tail rotor to match torque setting of motor.

**Action:** Decrease pitch by lengthening the rudder push-rod.

## Gyro Gain Adjustment

The gyro assists in holding the tail rotor, actually compensating for changes in wind direction or quick movements.

First check that the gyro is installed correctly by watching the rudder servo. While holding the rotor head move the rudder stick to the right and observe the direction the servo arm moves. Now quickly rotate the nose to the left, the servo horn should move in the same direction. If the rudder servo horn moves in the opposite direction reverse the gyro direction.

Generally the starting setting for the gyro gain is 60%, keep increasing the gain setting until the tail starts oscillating back and forth, then reduce the setting slightly.

**Problem:** Tail rotor makes sudden uncontrolled rotations.

**Action:** The gyro direction is possibly set in the wrong direction.

## Before Flying Your Helicopter

Before each flight, check that all bolts and screws are tight. Simply flying your helicopter, will loosen any screws which are not threadlocked or secured with a lock nut.

## First Flights

For the beginner pilot, a training pod is strongly recommended to assist in learning to hover the helicopter with substantially reduced risk of crashing. These systems provide an on ground training capability to allow pilots to become familiar with the helicopter before actually leaving the ground. (Optional Item) Part # CN2007A.

## Radio

Always turn the transmitter on first, then the turn on your receiver. Before every flight, it is recommended that a range check is performed. This is performed by walking away from your helicopter with the antenna fully collapsed to 30 paces and have someone verify that all control surfaces are operating. If at any time the inputs being provided changes (signaled by the person assisting you), then there may possibly be a communication problem. If you do not make this distance, have an experienced modeler check over your setup. do not fly until then.

## 12. Pre-Flight

### Basic Hovering

When all is set, ready and checked, attach your training gear/pod and plug in your battery.

- 1) Place the helicopter pointing into the wind and stand behind the model about 15' away.
- 2) Always watch the nose of the helicopter, move the rudder left and the nose will move left.
- 3) Start by increasing the throttle slowly until the helicopter rises 2-6 inches off the ground then set it back down.
- 4) Repeat this process until you become comfortable with the holding the model in the same spot for a few seconds then land it.

After some time at this you can increase the height slightly up to 1 foot (be very careful not to get too high) as you are practicing taking off and landing. This is the most basic but required skill for the beginner to learn.

### Beyond Hovering

It cannot be stressed enough that mastering the hovering skill is crucial to becoming a good helicopter pilot. As you progress in your learning, always practice hovering until you are completely comfortable in holding the helicopter in any direction at any altitude. Perfecting hovering enables you to learn all the types and styles of helicopter flying, forward flight, loops and rolls, 3D (aerobatic flying) and anything you want to do with your Swift helicopter as it can be set up for a beginner through to expert. Lastly, have fun!

### Pre-Flight Checklist

- 1) After turning radio on, move each servo separately, looking for unusual or excessive movement.
- 2) Lubricate the main shaft above the swashplate and the pitch slider on the tail output shaft with oil.
- 3) Inspect the main and tail rotor grips for play or binding.
- 4) Turn the main gear in both directions to feel if a problem is developing in the drive train.
- 5) Check the connectors on the battery(s), servos, and receiver to ensure they are still connected.

### Pre-Flight Check Up and Trim Adjustments

All trim adjustments are to allow you to lift the helicopter straight up and can be made one click at a time on the radio.

1) Collective & Throttle: Slowly raise the throttle stick, the helicopter should lift off at half stick. If it tends not to lift off increase the hover pitch on the radio or increase the throttle trim. If the helicopter lifts off before mid stick decrease these settings.

2) Rudder: When the helicopter is ready to take off, make a correction trim first then use the rudder stick to control the Left & Right. Note, now is a good time to make a final adjustment on the gyro, see gyro manual.

3) Elevator: If at hover the helicopter tends to move forward, move the trim down, if it moves backward move the trim upwards. Use the elevator stick to control the Forward & Backward.

4) Roll (Aileron): If at hover the helicopter tends to move left, move the trim right, if the helicopter moves to the right move the trim left. Move the Aileron stick to control the slide of the helicopter to the Right & Left.

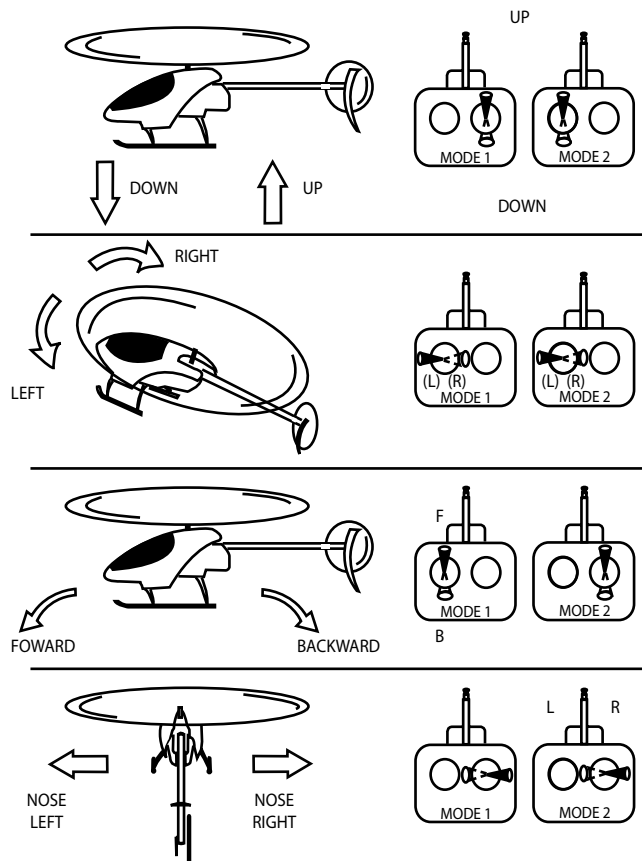

# 13. Replacement Parts



CNE501  
Canopy Standoffs &  
Grommets



CNE502  
CCPM Bellcrank Set



CNE508SL  
Solid Main Shaft - Triple  
Bearing



CNE510  
Main Gear With Auto-  
rotation Hub



CNE510A  
Main Gear Only



CNE510B  
Auto-rotation Hub &  
Bearing Only



CNE511  
Upper Shaft Collar



CNE512  
Landing Struts



CNE513  
Landing Skids



CNE514  
Carbon Fiber  
Support Frame



CNE516  
Washout Assembly



CNE556  
Head Block



CNE518  
Seesaw Shaft



CNE519  
Seesaw Assembly



CNE520  
Black Rubber  
Dampeners



CNE521A  
Feathering Spindle  
Reinforced



CNE522  
Main Blade Grip  
Spacers



CNE523  
Main Blade Grips



CNE524  
Bell Mixer Set



CNE525  
Flybar Control  
Arms



CNE526  
Flybar



CNE527  
Flybar Paddles



CNE528  
Tail Gear Box



CNE529  
Tail Gear Box Gear  
With Pin



CNE530  
Tail Rotor Shaft



CNE531  
Swift 16/550 Tail Drive Belt



CNE532  
Swift 16/550 Tail Boom



CNE533  
Transmission Gear  
With Pin



CNE534  
Rudder Control  
Rod Set



CNE535  
Fin Mounts

## 13. Replacement Parts



CNE536A  
Carbon Fiber Fin Set



CNE537  
Tail Pitch Slider



CNE538  
Tail Pitch Lever



CNE539  
Tail Rotor Hub



CNE540  
Tail Blade Grips



CNE541  
Tail Rotor Blades



CNE542  
Tail Transmission  
Gear Box



CNE543  
Tail Boom  
Support Set



CNE544  
Tail Servo Mounts



CNE545  
Pushrod Set



CNE546  
Ball Link Set  
(22 Long, 4 Short)



CNE549FPW  
Fiber Glass  
Canopy



CNE550  
Windshield



CNE551  
Decal Set



CNE553  
Rubber Battery  
Clamps (4)  
\*Requires 4



CNE561  
CNC Machined  
Swashplate



CNE563  
CNC Machined  
Motor Mount



CNE572  
Carbon Switch  
Plate



CNE573  
Elevator Carbon Plate



CNE574  
Carbon 550 Main  
Frames  
(Left and Right)



CNE575  
Front Electronics Tray



CNE577  
Carbon Gyro Plate



CNE579  
Carbon Main Shaft  
Supports (2)



CNE580  
Metal A-Arm



CNE581  
Metal Elevator Bell-  
mixer



CNE582  
Elevator Bearings  
28



CNE583  
Elevator Arm Spacers



CNE584  
Main Frame Brace



CNE585  
Switch Plate Standoffs



CNE586  
Short Spacers x6

# 14. Replacement Parts



CNE587  
Motor Mount  
Spacer (2)



CNE588  
Bell Crank  
Spacer (2)



CNE589  
Elevator Plate Standoffs



CNE590  
Transmission Box  
Spacer (2)



CNE591  
Driven Tail Hub

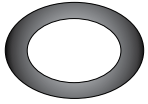

CNE592  
Tail Hub Spacer



CNE593  
Upper Bearing Block



CN2217S  
Silver Screw Caps  
(10)



CNBB364  
CCPM Bell Crank  
Bearing (4)



CNBB364  
Tail Pitch Lever  
Bearing (4)



CNBB0730  
Seesaw Bearing (2)



CNBB0384  
Tail Blade Grip  
Bearings (4)



CNBB1350  
Tail Gear Box  
Bearing (2)



CNBB614T2  
Main Blade Grip  
Thrust Bearing (2)



CNBB814  
Main Blade Grip  
Radial Bearings (2)



CNBB1019  
Upper/Lower Bearing  
Block Bearing (1)



CNBB4102  
Transmission Gear  
Bearing (2)



CNBB610  
Tail Pitch Slider  
Bearing (2)



CNBB364  
Bell Mixer Bearing (4)



CNBB1030  
Rotor Hub Bearing (2)

# 15. Upgrades



CNE556-1  
CNC Main Rotor  
Hub Only



CNE566-2  
CNC Washout Guide



CNE557  
CNC Blade Grip  
(1pc)



CNE557-1  
Main Blade Grip  
Only



CNE557-2  
Main Blade Grip  
Arm Only



CNE558  
CNC Bell Mixer



CNE559  
CNC Flybar Control Arms



CNE560  
CNC Washout Arms



CNE564  
CNC Seesaw Spacer



CNE567S  
CNC Tail Boom Clamp

## 15. Upgrades/Accessories



CN265166C  
Rotortech Carbon 515mm  
Main Blades



CN265501  
Rotortech Carbon  
550mm Main Blades



CN265666  
Rotortech Carbon  
560mm SG 3D  
Blades



CN260762  
Rotortech Carbon  
75mm Tail Blades



CN25080  
Carbon 80mm Tail  
Blades



CN25510  
Century Carbon Fiber  
Paddle



CNMG509  
Motor Gear- 9T,  
5MM, 1.0



CNMG510  
Motor Gear- 10T,  
5MM, 1.0



CNMG511  
Motor Gear- 11T,  
5MM, 1.0



CNMG512  
Motor Gear- 12T,  
5MM, 1.0



CNMG513  
Motor Gear- 13T,  
5MM, 1.0



CNMG514  
Motor Gear- 14T,  
5MM, 1.0



CN2215ASF  
Machined Head Button



CNE271  
Century Outrunner  
550 Plus



CNE273  
Century Outrunner  
600 Plus



CN2235  
Triple B.B Tail Assembly



CNE566  
CNC Tail Gear Box  
(Pitch Slider not included)



CND421900Y  
Foam Insulator  
with Velcro



CNE455  
Electron 55/70  
4S ESC



CNE480  
Electron 80/100  
6S ESC

## 16. Motors and Pinions

Use this table as a guide, your setup and flight conditions will make these results fluctuate. For ultimate performance with head speeds reaching close to 2000rpm, Century recommends the use of high quality flight packs with at least 20C constant discharge rate.

Motors	4S (14.8V)		5S (18.5V)		6S (22.2V)	
	Pinion	Headspeed	Pinion	Headspeed	Pinion	Headspeed
<u>Century 550 PLUS</u> (CNE271) RPM/V: 1470	9T	1730	9T	2160	N/A	
<u>Century 600 PLUS</u> (CNE273) RPM/V: 1110	13T	1890	10T	1820	9T	1990
<u>NEU 1907 1.5Y</u> (NEU190715Y) RPM/V: 915	14T	2040	11T	2000	N/A	
<u>Kontronik Tango 45-10</u> (KONG2320) RPM/V: 920	14T	1700	13T	1940	N/A	
	N/A		N/A		10T	1920