

Swift Carbon 620SE

ELECTRIC R/C HELICOPTER

Kit Instruction Manual

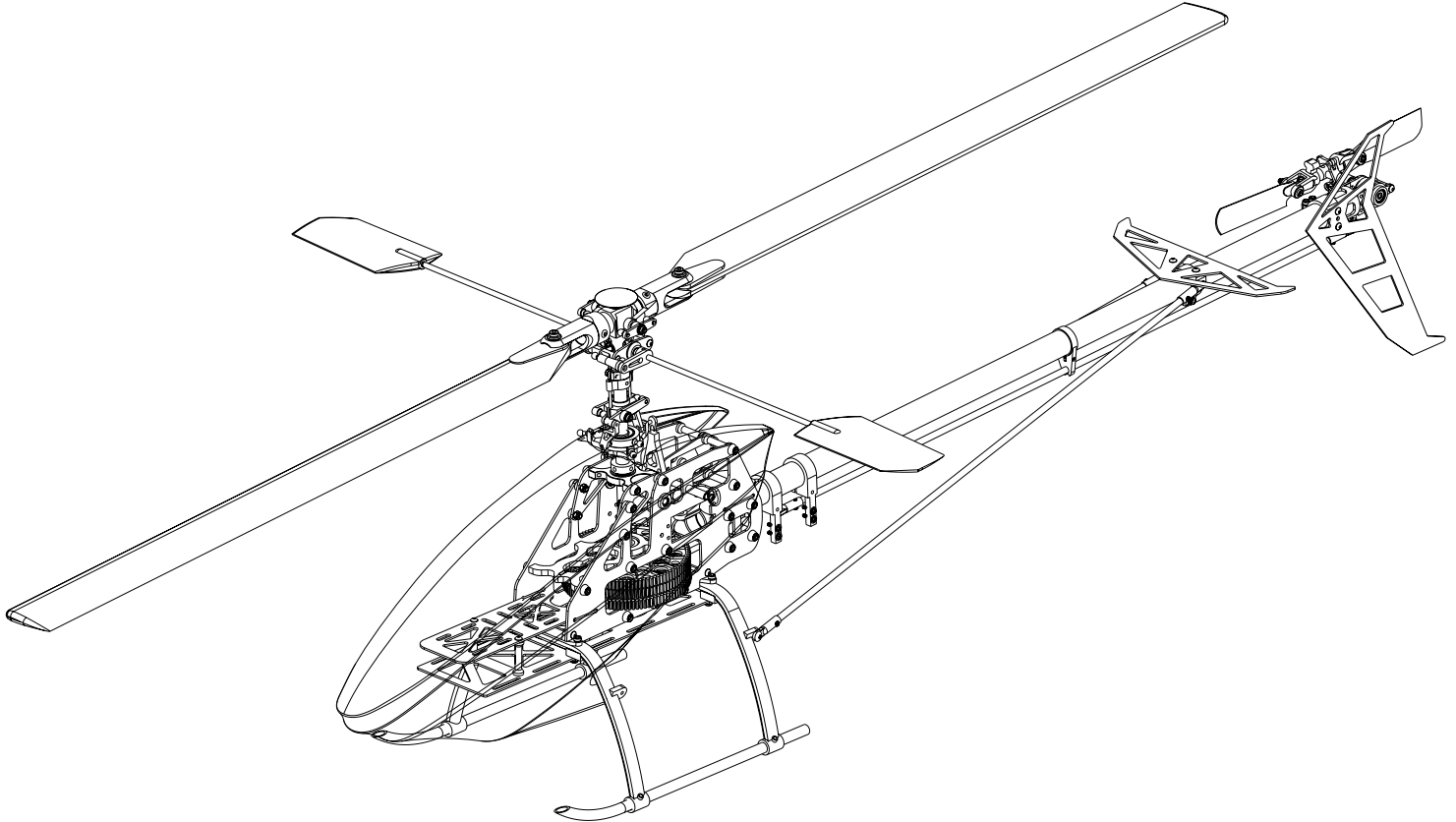

Mechanical Specs:

Main Rotor Blades: 600-620mm

Tail Rotor Blades: 75-85mm

Length: 113.3cm

Height: 34.4cm

Weight: 1.76kg (configured with brushless motor and servos)

Electronic Specs:

Speed Control: 50-85 Amp

Motor: 800-1250kv (based on battery)

Battery: 4S-10S Li-Po

Main Gear: 96 Tooth

Pinion: 9-14 Tooth

Head Speed: 1600-2300 RPM

Century Helicopter Products

Designed and Developed in USA

2nd Edition May 2008 All rights reserved.

1. Introduction

Congratulations on your purchase of Century Helicopter Product's Swift Carbon 620SE Kit. The Swift Carbon 620SE is a high performance machine providing the agility and durability that is expected out of a helicopter of this caliber. The attention and praise by the R/C helicopter community is well deserved as the Century Swift line is unmatched in affordability, quality and performance.

In order to take advantage of your Swift's performance capabilities we recommend using a high quality computer radio system with 120 degree eCCPM mixing. The radio system should have at least 6 channels to use modern heading lock gyros, Standard servos can be used with a specialized high speed tail servo.

Warning

This radio controlled model is not a toy! It is a precision machine requiring proper assembly and setup to avoid accidents. It is the responsibility of the owner to operate this product in a safe manner as it can inflict serious injury otherwise. It is recommended that if you are in doubt of your abilities, seek assistance from experienced radio control modelers and associations. As manufacturer, we assume no liability for the use of this product.

Pre-assembly Information

Upon opening the kit, all components are in individual bags. Please thoroughly read through this manual before attempting assembly. Some specialized tools are recommended but not required for full assembly.

Be careful when opening each bag as not to lose any hardware. As a reminder, all metal to metal screw assemblies require "blue" thread lock compound, all metal to plastic screw assemblies require slow setting CA and all bearing race to metal shafts should use "red" thread lock compound.

Warranty

Your new equipment is warranted to the original purchaser against manufacturer defects in material and workmanship for 30 days from the date of purchase. During this period, Century Helicopter Products will repair or replace, at our discretion, any component that is found to be factory defective at no cost to the purchaser. This warranty is limited to the original purchaser and is not transferable. This warranty does not apply to any unit which has been improperly installed, mishandled, abused, or damaged in a crash, or to any unit which has been repaired or altered by any unauthorized agencies. Under no circumstances will the buyer be entitled to consequential or incidental damages. This limited warranty gives you specific legal rights. You also have other rights which may vary from state.

Century Helicopter Products

1740-C Junction, Ave.

San Jose, CA 95112

Fax: 408-451-1156

www.centuryheli.com

Lithium Polymer Battery Safety

For Lithium Polymer and NiMH/NiCD cell or battery packs purchased.

1. Never fast-charge any battery type unattended.
2. Never charge Li-Poly cells or battery packs at any rate unattended.
3. Only charge Li-Poly cells or battery packs with a charger designed specifically for lithium polymer chemistry.
4. Li-Poly cells can ignite because of unmatched cell capacity or voltage, cell damage, charger failure, incorrect charger setting and other factors.
5. Always use the correct charging voltage. Li-Poly cells or battery packs may ignite if connected to a charger supplying more than 4.5 volts per cell.
6. Always assure the charger is working properly.
7. Always charge Li-Poly cells or battery packs where no harm can result, no matter what happens. We suggest a brick box or likeness. Have sand handy in a bucket for any need to extinguish any fire. NEVER use water on any cells or battery packs.
8. Never charge a cell or battery pack in a model. A hot pack may ignite wood, foam, plastic, etc.
9. Never charge a cell or battery pack inside a motor vehicle or in a vehicle's engine compartment.
10. Never charge a cell or battery pack on a wooden workbench or on any flammable material.
11. If a cell or battery pack is involved in a crash:
 - a. Remove the cell or battery pack from model.
 - b. Carefully inspect the cell or battery pack for shorts in the wiring or connections. If in doubt, cut all wires from cell or battery pack.
 - c. Disassemble the pack
 - d. Inspect cells for dents, cracks and splits. Dispose of damaged cells.
12. Dispose of cells or battery packs as follows:
 - a. Discharge: with the cells or battery pack in a safe area, connect a moderate resistance across the terminals until the cell or battery pack is discharged. CAUTION: cell or battery pack may be hot.
 - b. Discard:
 - i. NiMH: place in regular trash
 - ii. NiCD: recycle (cadmium is toxic)
 - iii. Li-Poly: puncture plastic envelope, immerse in salt water for several hours and place in regular trash.
13. Handle all cells or battery packs with care, as they can deliver high currents if shorted. Shorting by a wedding ring, for example, will remove a finger.
14. Always store cells or battery packs in a secure location where they cannot be shorted or handled by children.
15. When constructing a battery pack, always use cells of the same capacity (mAh)
16. DO NOT store fully charged or discharged batteries in your helicopter.
17. When cutting wires, always cut ONLY ONE WIRE AT A TIME.

** Century Helicopter Products will not be liable for any damages that may occur to your helicopter due to any misuse or mishandling as explained above.

** Century Helicopter Products, its successors, heirs and assignees are not responsible in way for any and all bodily injuries) and/or property damage that may occur from the use of, or caused by in any way from Lithium Polymer and NiMH/NiCD cells or battery packs offered by and or distributed by Century Helicopter Products.

3. Required Items for Operation

This is the general list of items required to get the Swift Carbon 620 helicopter flying. Century produces a full spectrum of accessories and tools to assemble your helicopter. The Swift Carbon 620 is a electronic cyclic collective pitch mixing type helicopter requiring a standard helicopter radio (the helicopter radio requires eCCPM mixing for this model). The Swift Carbon 620 uses 4 servos to operate critical systems. Gyroscopes are required to operate the model safely.



Necessary Items "Not Included" in the kit.



Fastener and ball bearing dimensions

Hardware Description and Identification:

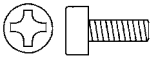
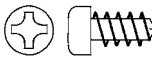
M3X6 = 3X6mm and can refer to screws or ball bearings.

<p>M3X6 Phillips Machine Screw</p>  <p>M - metric 3 - diameter 6 - length</p>	<p>M3X6 Self Tapping Screw</p>  <p>M - metric 3 - diameter 6 - length</p>	<p>M3X10 Socket Cap Screw</p>  <p>M - metric 3 - diameter 6 - length</p>	<p>M3X7x3 Ball Bearing</p>  <p>M - Metric Value 3 - Inside 7 - Outside 3 - Thickness</p>
--	--	---	---

WARNING: Do not overtighten bolts or screws possibly damaging threads of bolts or components.

Recommended Tools & Accessories

The tools and materials listed below are the minimum needed to build the helicopter:

- Screwdrivers - Slotted and Phillips head
- Long-Nosed Pliers
- Allen Wrenches - 1.5mm, 2.0mm, 2.5mm + 3.0mm
- Appropriate Socket Wrench
- Hobby Scissors
- Double Sided Foam Tape (1/16" - 3/32")
- Foam Rubber (Radio Packing)
- Thread lock liquid (e.g. Locktite)
- Hobby Grease (Super Lube)
- Oil to lubricate sliding shafts
- CA (Cyanoacrylate) Glue

In addition, the following will make assembly and setup easier, and prove useful later in your model toolbox:

- Part#CN2015 Hardened Tip Hex Screw Driver Set
- Part#CN2026 Pitch Gauge with Paddle Gauge
- Part#CN2034A 15° Curve Tip Ball link Pliers
- Part#CN2052 Main Blade Balancer
- Part#CN2055 Ball Link Sizing Tool
- Part#CN2070 Universal Flybar Lock
- Part#CN2219 Ball Link Easy Driver
- Part#CN2255 Control Rod Gauge
- Part#CNWI26555 5.5mm Nut Driver
- Part#CNWI26570 7.0mm Nut Driver

Hobby scissors
#CN2262

Pitch Gauge
#CN2027

Locktite
#CN2025BS blue
#CN2025RS red

Needle Nose Pliers & Cutter Pliers

Lubrication
#CN2024T



4. Before You Begin

Every attempt has been made to ease the assembly of your kit, at each step where there are complex instructions there are detailed written instructions to walk you through each step. Remember to take a few minutes before each step to carefully examine each process to become familiar with the parts and assembly before beginning that step. All hardware associated with the part has been bagged and bundled together. When installing a part, make sure to open each bag individually to ease construction of your Swift Carbon 620SE

Symbols used to help assist you in building the kit:



Whenever this symbol appears, use CA (cyanoacrylate) glue.



Whenever this symbol appears, use blue thread lock. (CN2025BS)



Whenever this symbol appears, use red thread lock. (CN2025RS)



Whenever this symbol appears, use grease.

5. Safety

Before flying, please check to make sure no one else is operating on the same frequency.

Before flight, please check if the batteries or transmitter have enough capacity.

Before turning on the transmitter, please check to ensure the throttle stick is in the lowest position. IDLE switch is Off.

When turning on the unit, please follow the power on/off procedure. Power ON - Turn on the transmitter first and then turn on the receiver. Power OFF - Turn off the receiver first and then turn on the transmitter. If this protocol is not followed, control of the model may be lost.

Before operation, check movement of all controls are smooth and no linkages are binding. Carefully inspect servos for full operation.

Check for missing, damaged, or loose items. Carefully inspect main rotor blades and tail blades for damage. If damaged, replace with new ones to ensure a safe flight.

Check all ball links to ensure proper fitment. If loose, replace ball links with new ones.

Check servo plugs, ESC plugs, motor plugs, gyro plugs, and battery plugs to make sure they are securely fastened. A loose plug may result in a complete lose of control over the model.

Check the tail belt tension to make sure the belt is not too loose. No more than 5mm movement when pushed inward.

6. Assembly Instructions

Main Blade Grip

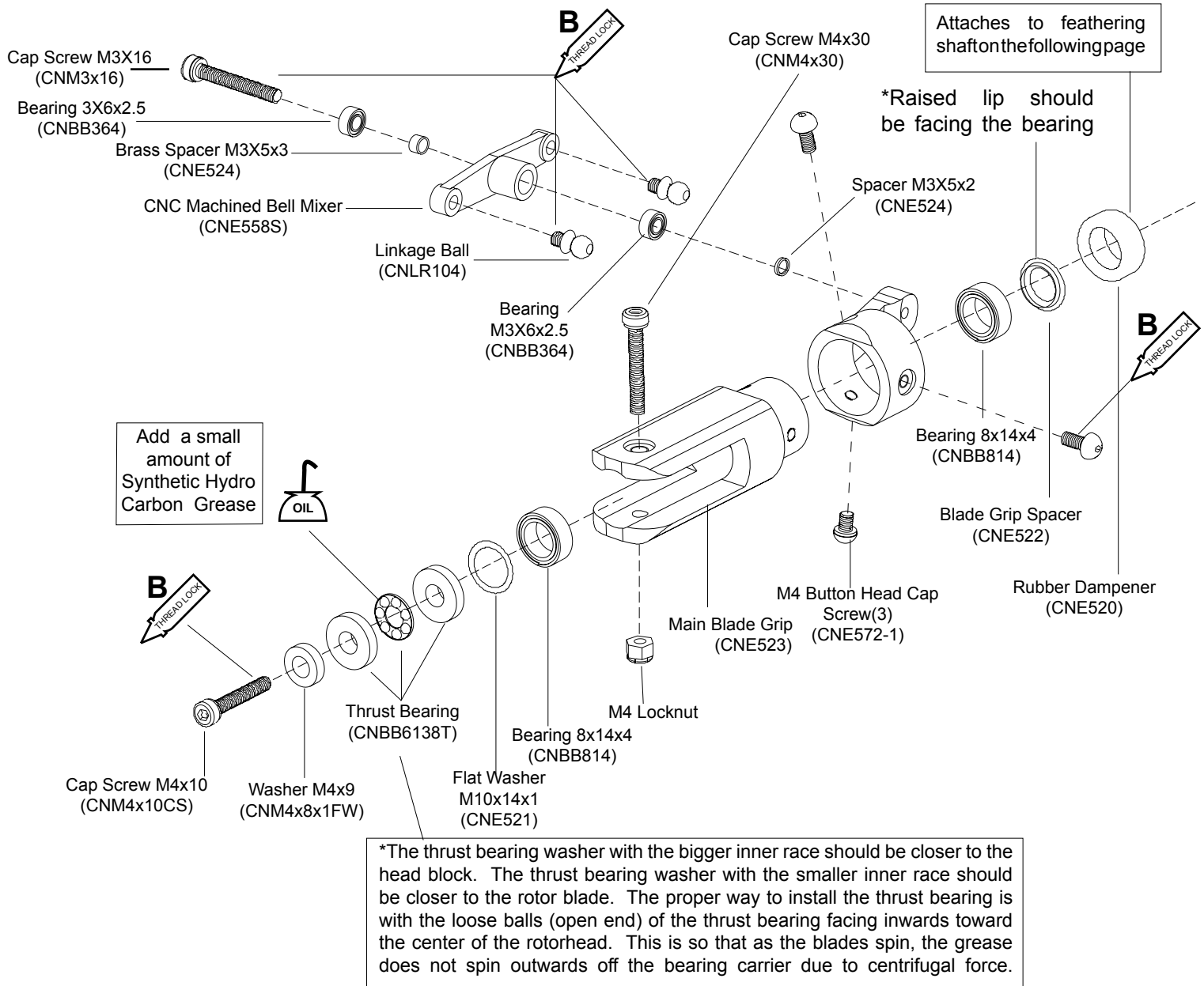

6. Assembly Instructions

Head Block

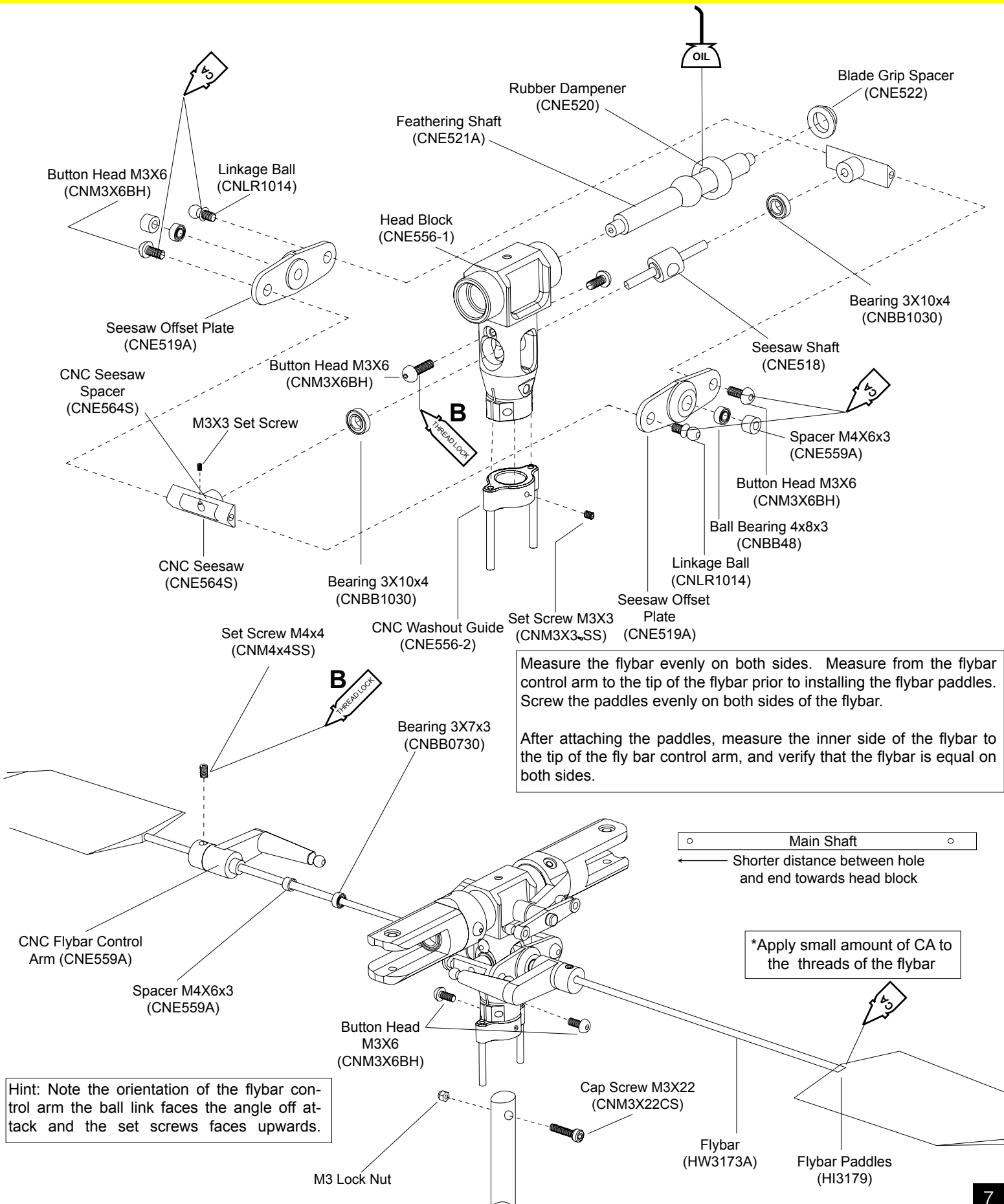

6. Assembly Instructions

Adjusting the Flybar

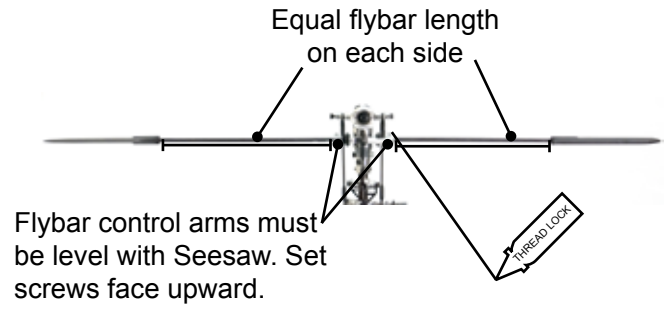
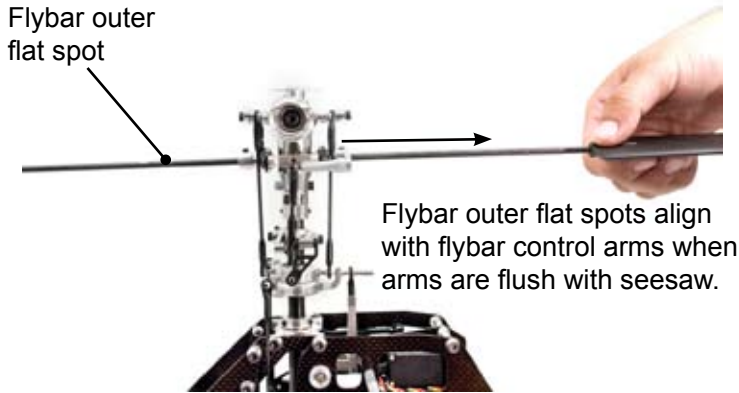

Swashplate and Washout Assembly

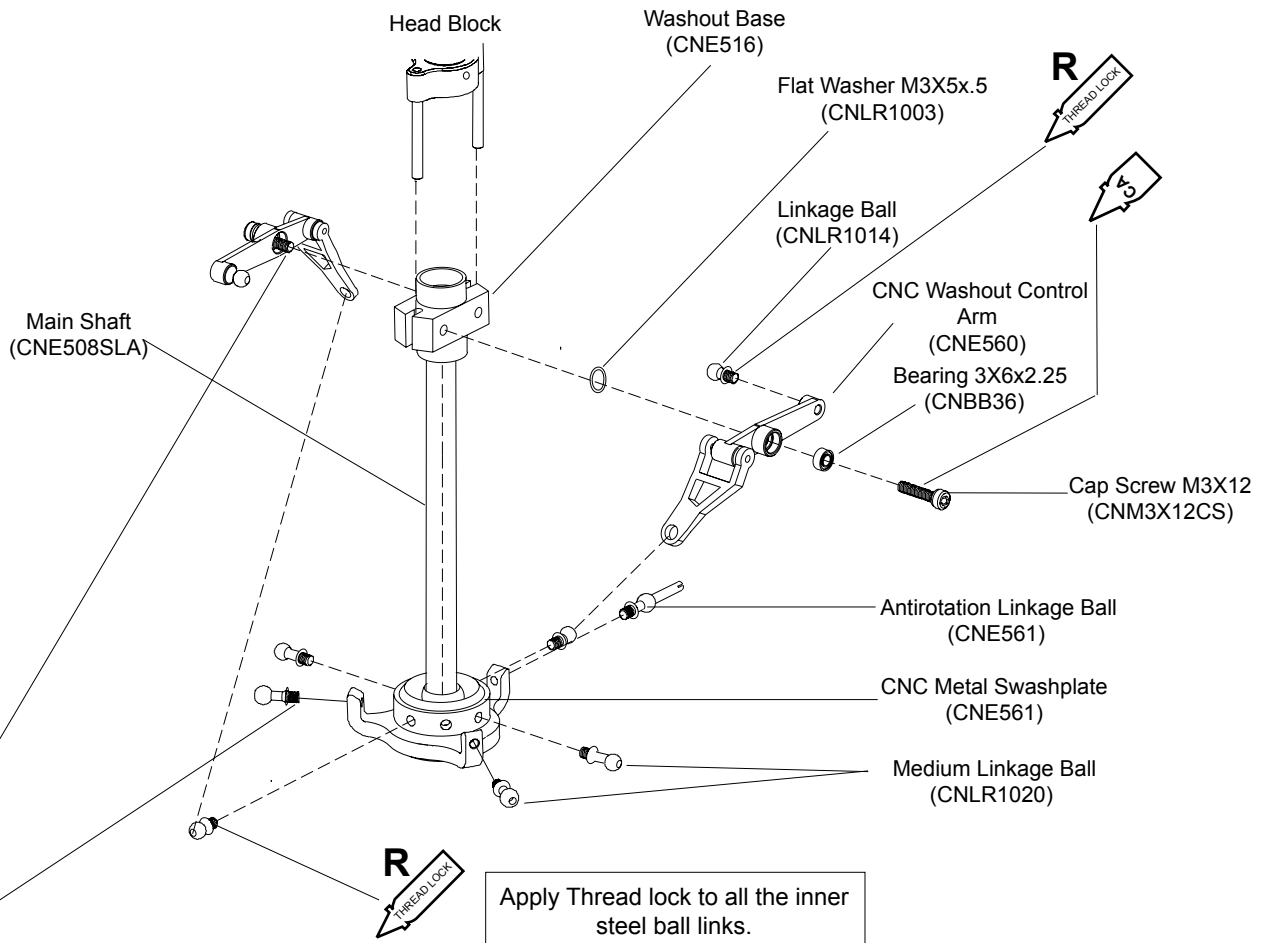

*Hint: Undo the cap screws and linkage balls to the assembled parts. Apply CA on metal to plastic assembly. Apply blue thread lock on metal to metal assembly. Do not over tighten when screwing the attached assembly to its subassembly.

6. Assembly Instructions

Upper Bearing Block Assembly

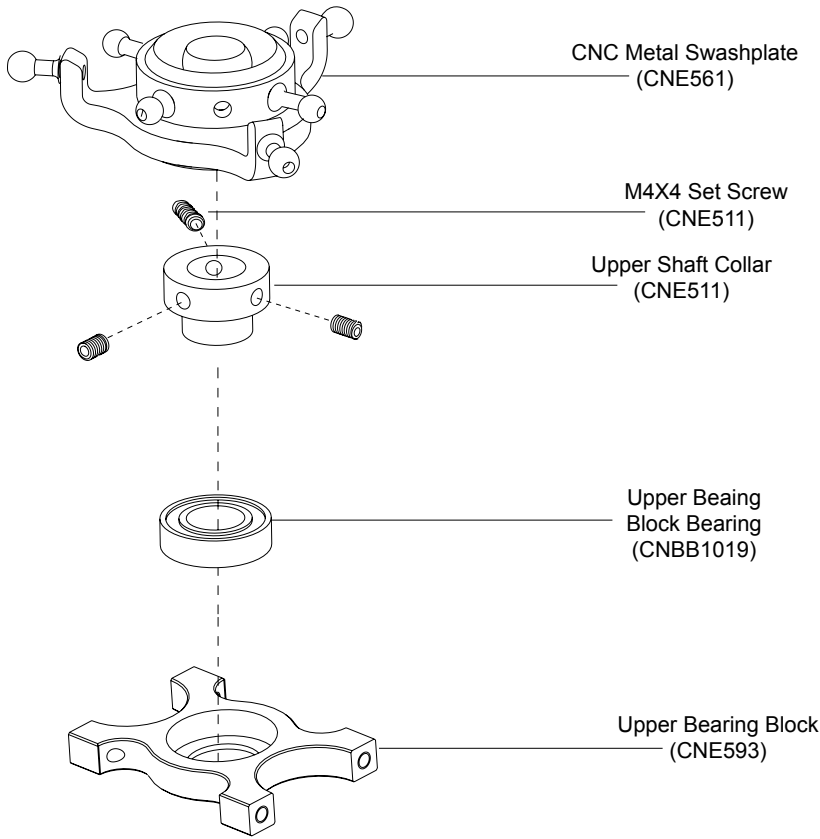

B **THREAD LOCK** ***Blue threadlock all cap screws in this diagram, that screw into metal parts***

Elevator Servo Plate Assembly

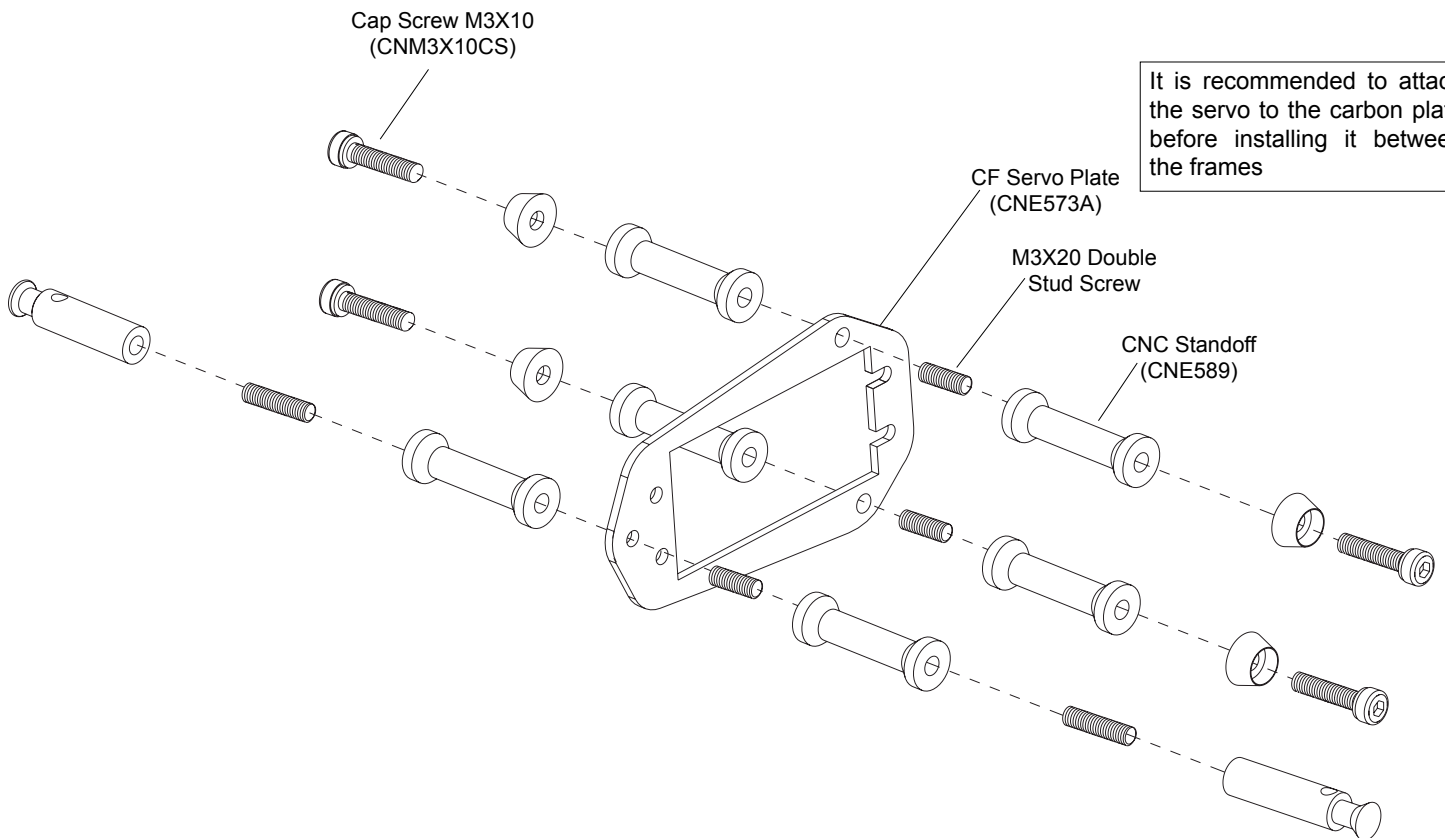

It is recommended to attach the servo to the carbon plate before installing it between the frames

6. Assembly Instructions

Main Frame Assembly

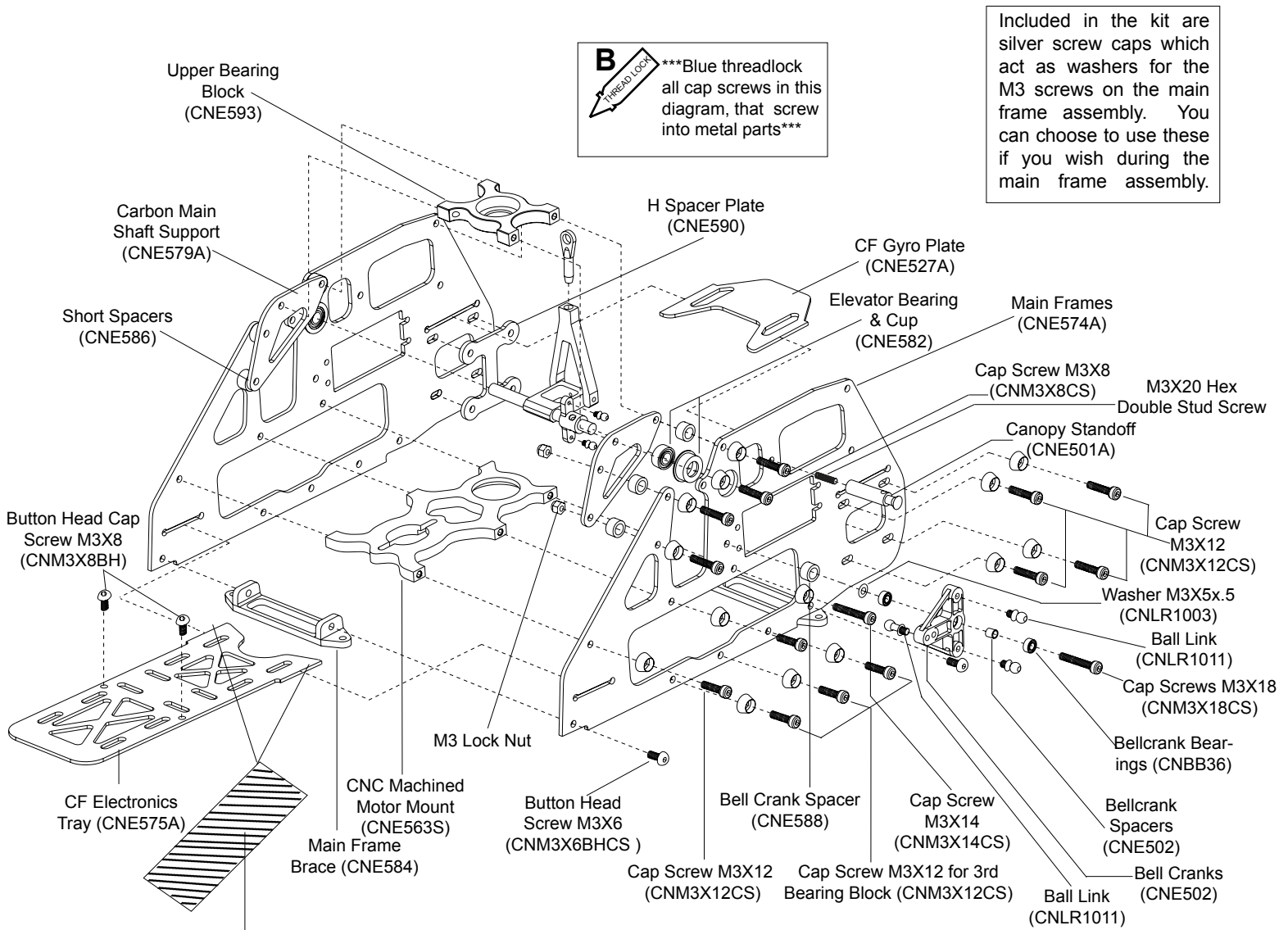

Included in your kit is a small piece of sand paper. Tolerances are so fine on this kit that you may have to sand down the edges of your carbon radio tray and gyro plate in order for them to fit perfectly. When sanding, remove small amounts of material and test fit the parts. You want the parts to fit snugly in place. If the parts are loose, apply a small dab of CA to keep the parts in place. *WARNING: Before sanding, make sure you and your model are in a well ventilated area, or outside. When sanding carbon, you must wear a dust mask as inhaling the dust particles can be harmful to your health.*

You may find it easier to install the main gear hub assembly if you place it in between the main frames while they are being put together.

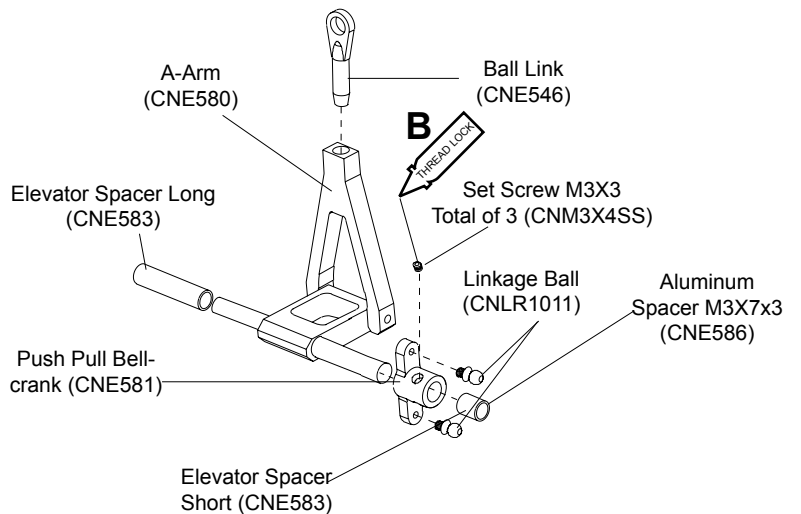

6. Assembly Instructions

Tail Gear Box Assembly

*The thrust bearing washer with the bigger inner race should be closer to the head block. The thrust bearing washer with the smaller inner race should be closer to the rotor blade. The proper way to install the thrust bearing is with the loose balls (open end) of the thrust bearing facing inwards toward the center of the rotorhead. This is so that as the blades spin, the grease does not spin outwards off the bearing carrier due to centrifugal force.

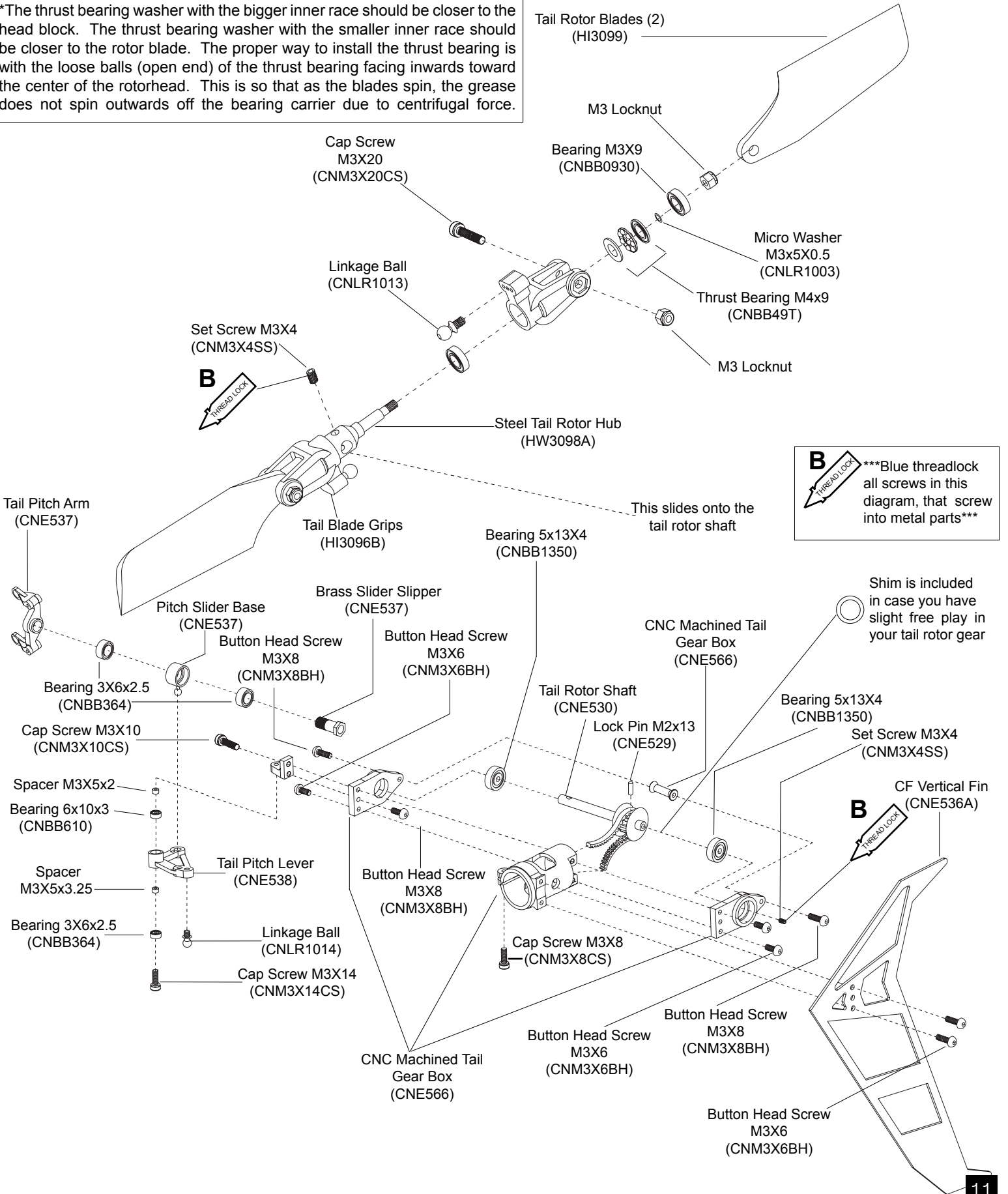

6. Assembly Instructions

Autorotation Hub Assembly

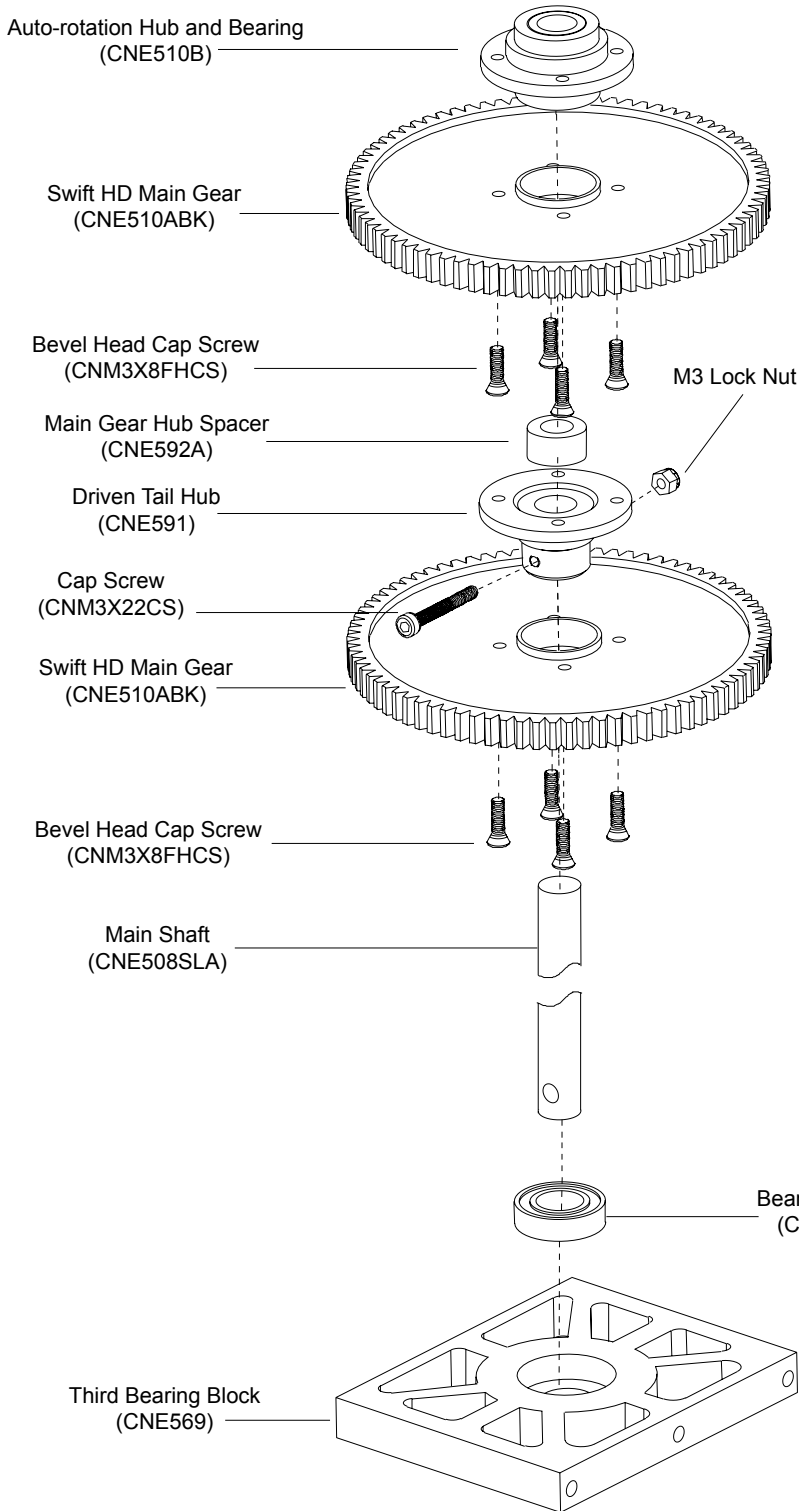

Optional Stacked Gear Setup (For High Voltage Power Systems)

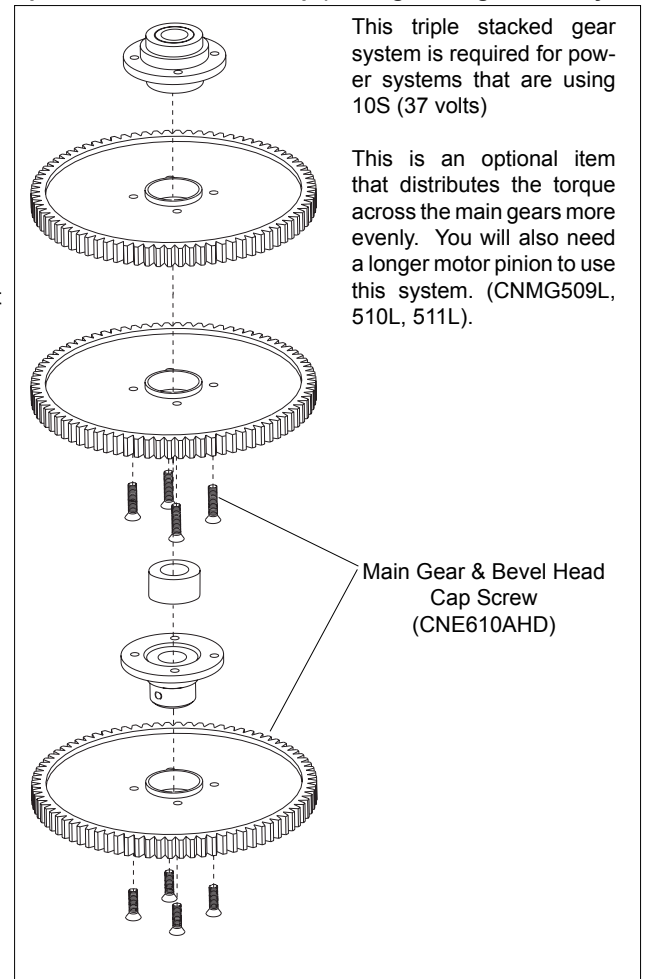

6. Assembly Instructions

Tail Transmission Assembly

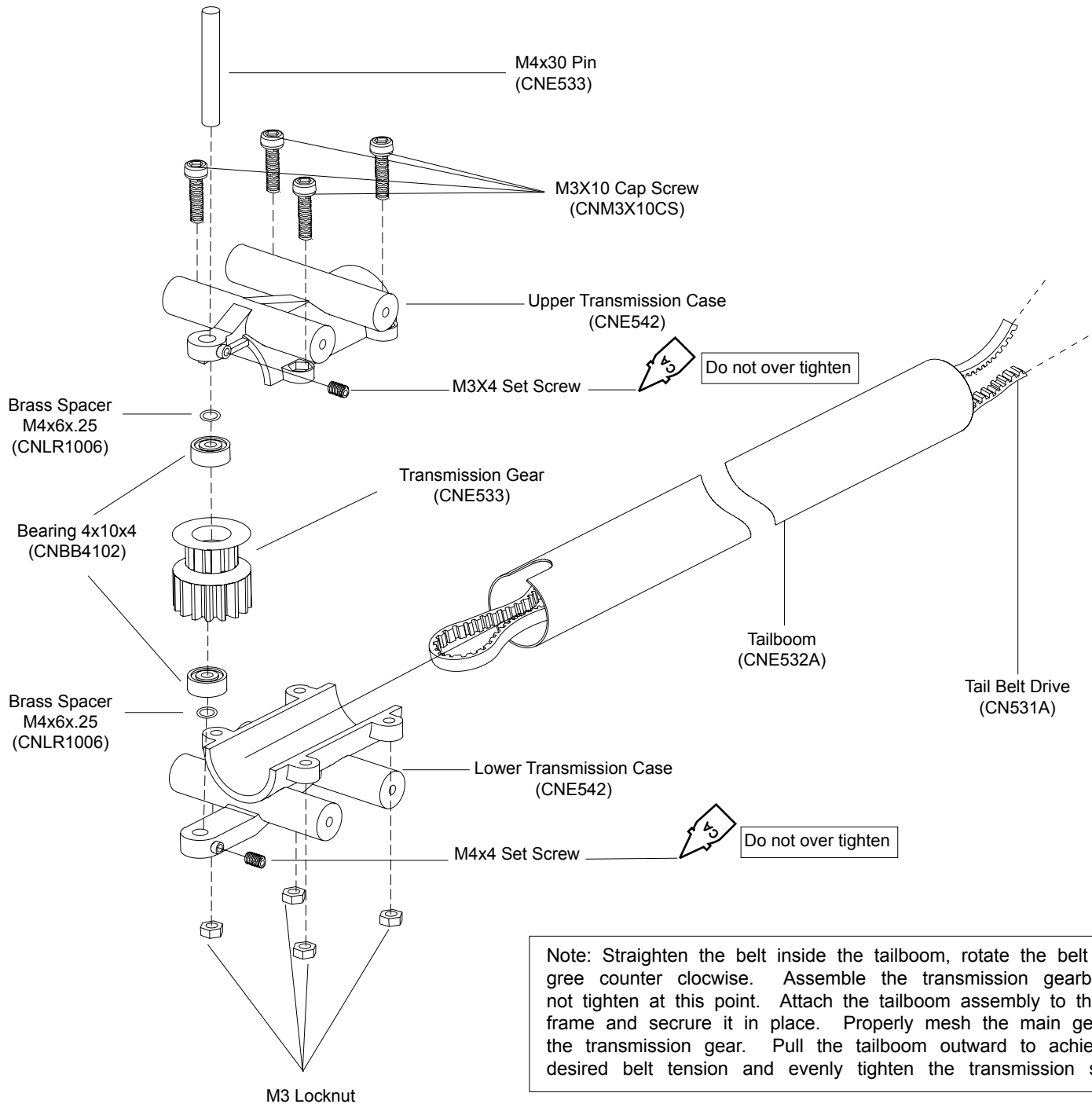

Back of Heli

Tail Drive Belt Direction

Front of Heli

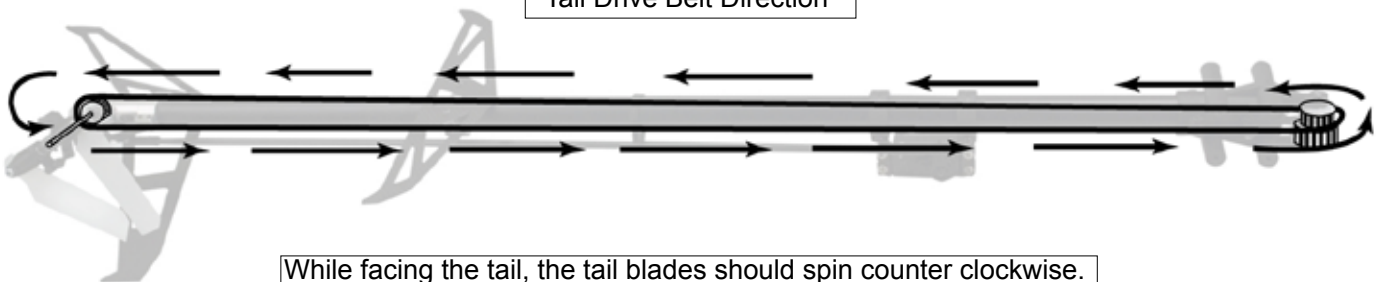

6. Assembly Instructions

Tail Component Assembly

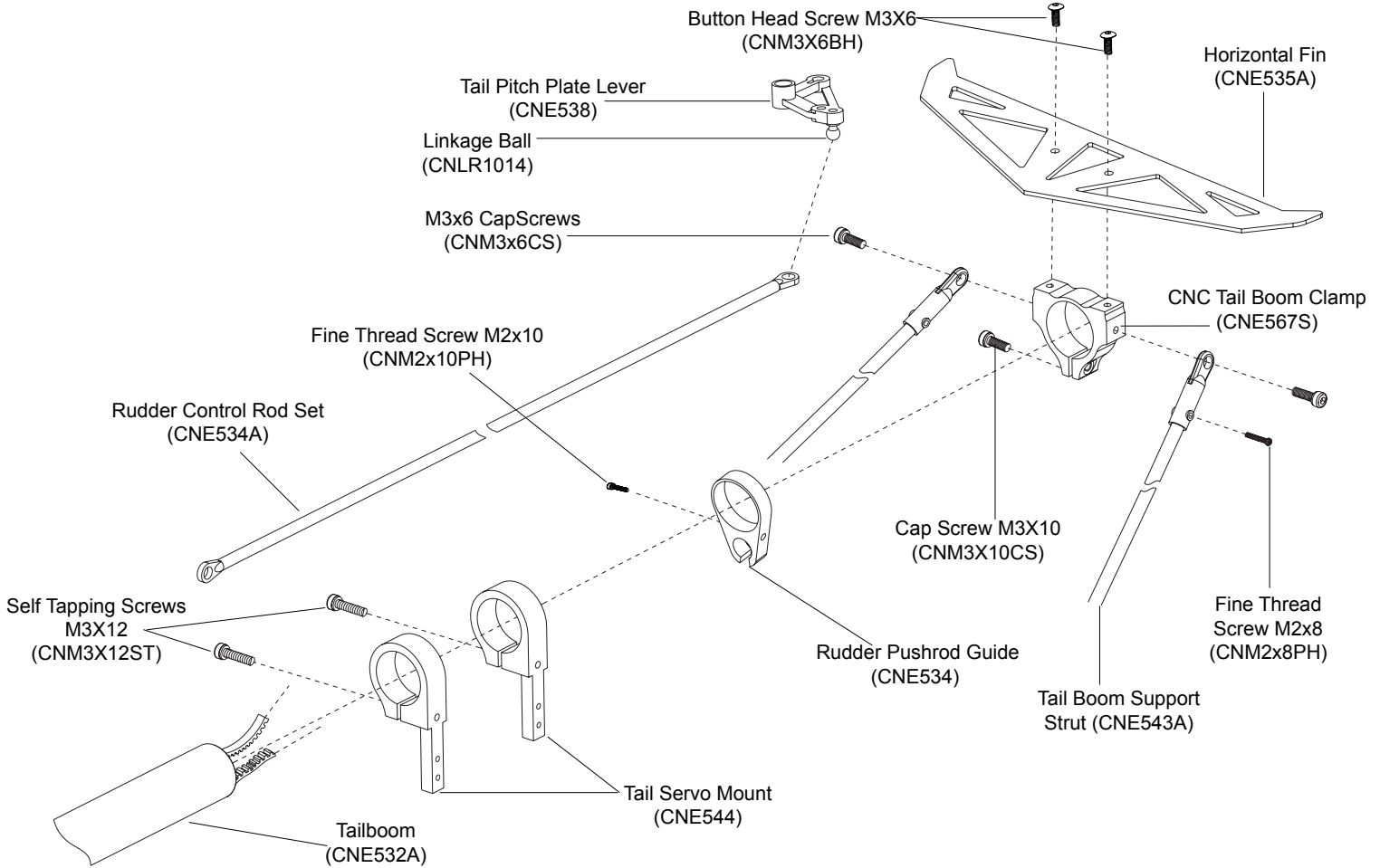

Tail Boom Support Struts and Rudder Control Rod

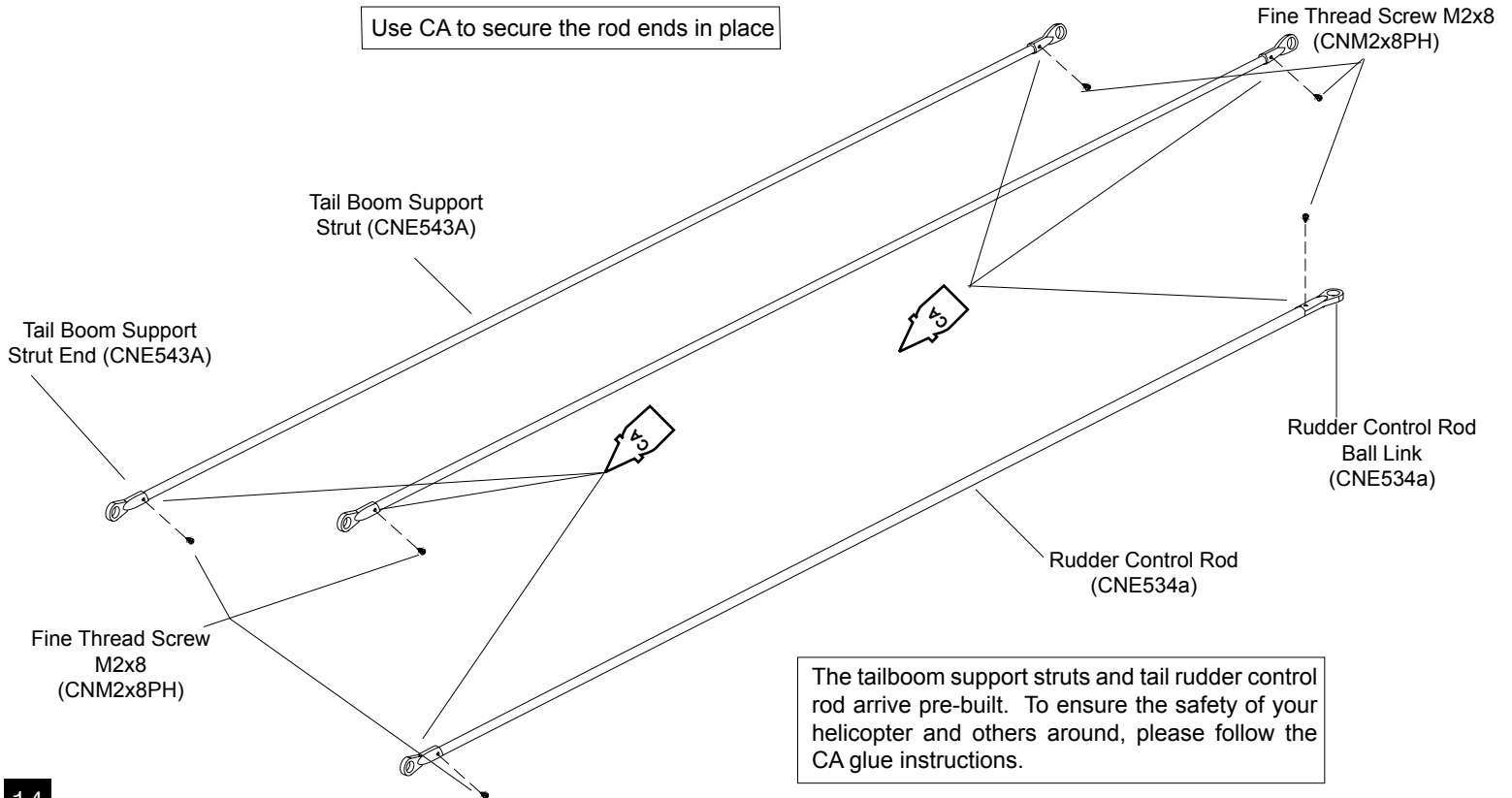

6. Assembly Instructions

Landing Gear Assembly

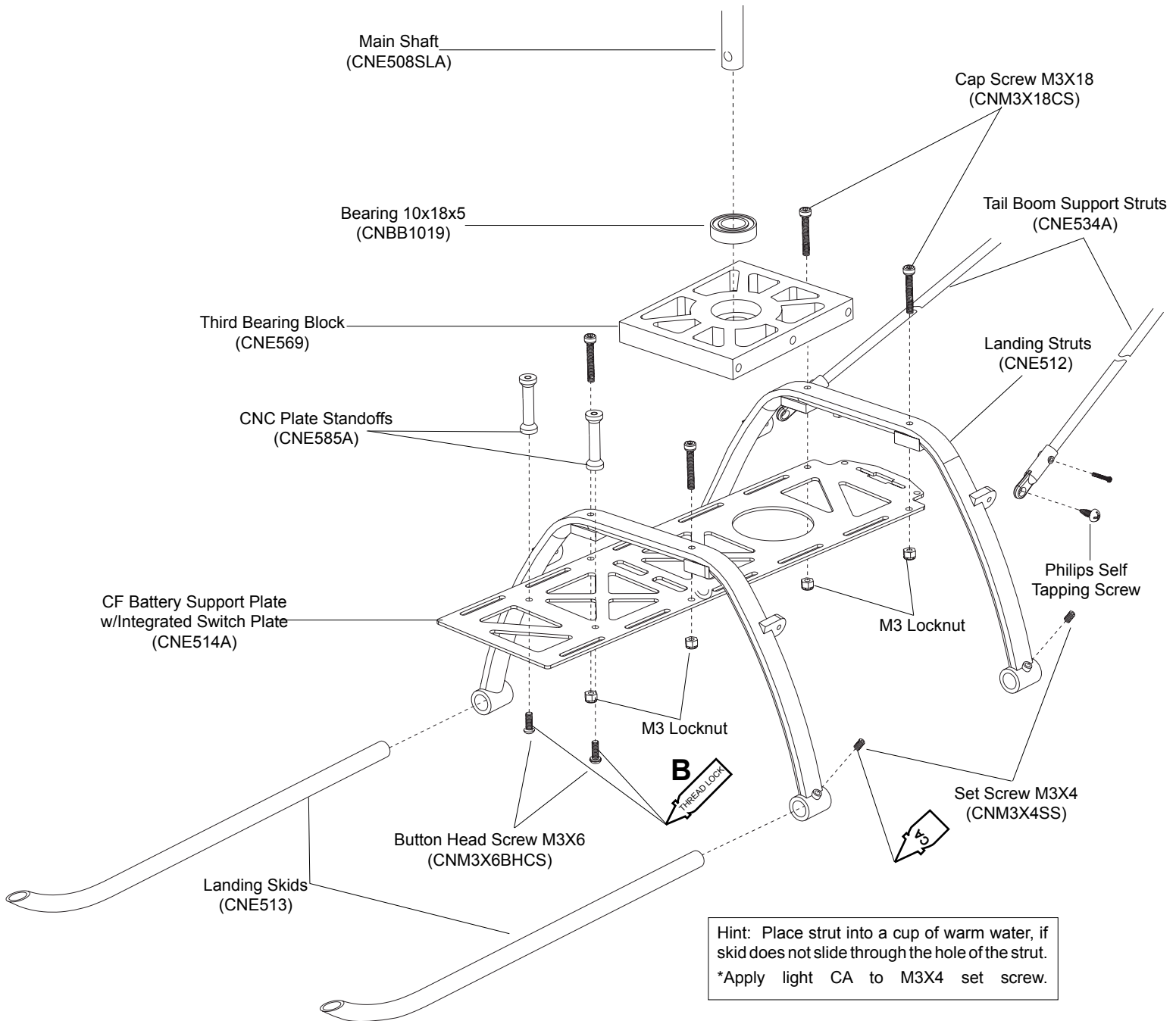

7. Putting Together Your Model

Assembling the Components

After completing the previous steps, the following instructions are for putting together the sub-assemblies. Please follow the instructions and any hints along the way to ensure that you have a properly flying model.

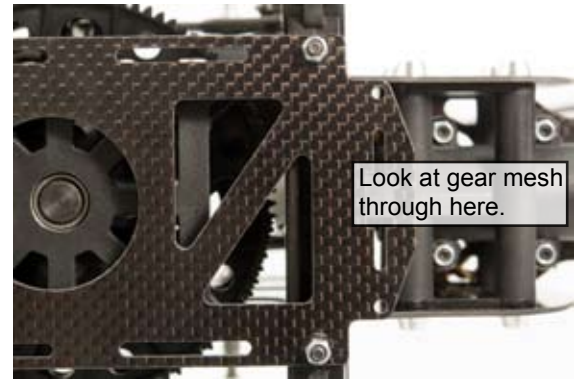

1) Align the mounting posts from the front transmission gearbox with the mounting posts at the rear of the main frame. The horizontal fin on the tail boom facing should face up so the rudder pushrod and tail boom support struts hang below the tail boom.

2) Using the hardware provided attach the tail section to the frame section. **Do not fully tighten the screws till the following step.**

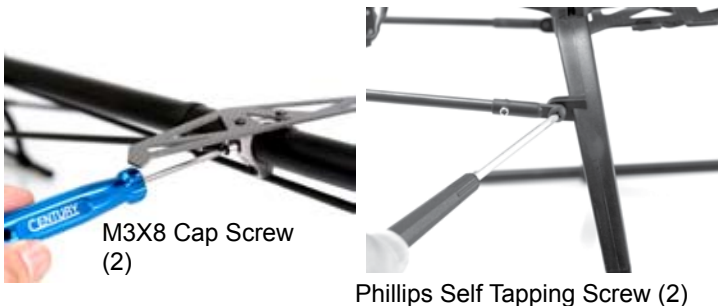

1) Align the transmission gear mesh before fully tightening the screws holding the frame and tail sections. Good alignment is smooth and free of resistance without slipping or skipping teeth. (HINT:) place a strip of paper between the gears to give proper clearance. Turn the main gear while feeding the strip of paper between through the gears. If the strip of paper comes out torn, then the gear mesh is too tight. If the strip of paper comes out not matching the obvious accordion pattern from the gears' teeth, then the gear mesh is too loose.

2) Attach the tail boom support struts to the horizontal fin clamp and the rear mounting posts on the landing struts as shown by tightening the four set screws. (HINT:) To help prevent rotation of the horizontal fin mount, wrap the area under the horizontal fin mount with a few layers of electrical tape.

1) Mounting the switch underneath the battery tray keeps it away from moving parts and allows you to access the switch when the canopy is on. Remember to use locktite on the M3 socket head cap screws.



7. Putting Together Your Model

Servo Linkage Lengths

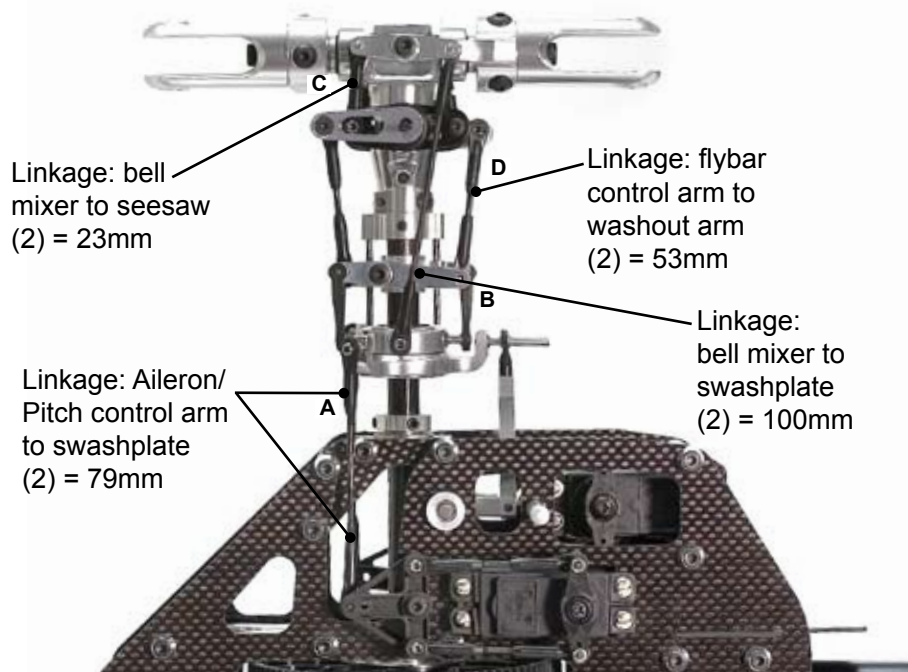

1) Before proceeding to measure and install the pushrods, make sure you have adjusted the flybar to it's optimal level (flybar paddles flat and parallel to the ground). Adjust the flybar until the outer flat spots align with the set screws in the flybar control arms (set screws facing upward and flybar control arms are flush up against the seesaw).

2) Make certain that the flybar is equal in length on both sides of the rotor head before tightening the flybar control arms. Set the flybar control arms flush and level to the seesaw and **tighten the set screws using locktite.**

It is very important that before you install the pushrod linkages that your transmitter's batteries are fully charged. Then remove all the servo horns from the servos and center all the mechanical or electronic trims on the radio.

Due to the different types of radio and servos that are chosen to install into the helicopter, match each pushrod to the lengths in the table for optimum setup.

Note: All dimensions are in millimeters and are measured from the centers of the control balls or ball ends.

Location	Length	ID
Aileron/Pitch Control Arm to Swashplate	79mm	A
Swashplate to Bell Mixer Link	100mm	B
Bell Mixer to Seesaw	23mm	C
Flybar Control Arm Linkage to Washout Arm	53mm	D

These lengths should allow for approximately +/- 12 degrees of pitch with 0 degrees at center stick (typical 3D setup).

Optional Tools Necessary for Perfect Setup



CN2255 Control Rod Setup Gauge

Easily duplicates pushrods by attaching a master pushrod and match new pushrods as they are assembled. Gauge has millimeter scale for accurate lengths center to center.



CN2027 G-Force Pitch Gauge

Provides easy pitch setup of main blades. Self centering weighted indicator offers easy to read pitch numbers during setup. No more need to eyeball the amount of pitch that's being dialed in.



CN2050 Paddle Gauge v.2

Allows you to gauge your paddles during pitch setup. Easy clip on with thumb screws for a secure fit.

8. Installing and Adjusting Control Components

Adjusting the Servos

There are three servos that are mounted on the left and right main frames. They work together to tilt the swashplate producing the collective pitch, roll cyclic pitch (aileron control) and the fore-aft cyclic pitch (elevator control). Before beginning this section you should center all servos using the radio. All servo arms must be set with linkages as pictured at 90 degree angles. **All servos mount with M2.5x12 self tapping screws, M2 servo balls and M2 Nuts.** IMPORTANT: Century logo on all ball links must face OUTWARD as pictured.

View: Left Side

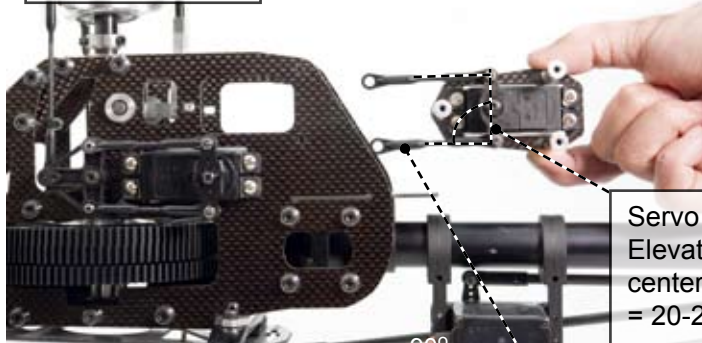

Servo Arm:
Elevator Servo
center to hole.
= 20-22mm

Linkage:
Elevator Servo
to bellcrank (2)
=50mm

Century logo on all ball links must
face OUTWARD as pictured

View: Left Side

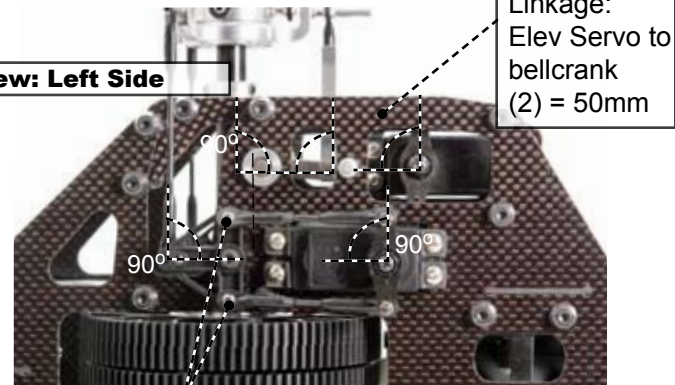

Linkage:
Elev Servo to
bellcrank
(2) = 50mm

Linkage:
Pitch Servo to
bellcrank
(2) = 50mm

Use the 4 servo screws and 2 servo mounting tabs to mount the elevator servo with the servo arm output facing toward the front inside of the frame (pictured above). The distance from the center of the servo to the center of the ball on the servo arm should be between 20-22mm

Place one servo ball to the pitch servo arm facing inside toward the frame. Attach two 50mm linkage to the servo arm ball then to the balls on the elevator bellcrank (CNE581).

The pitch servo will mount with a full servo arm on the lower opening of the left side of the main frame. The distance between the steel balls (center of ball) on the servo arm should be 12.5mm. Use the 4 servo screws and 2 servo mounting tabs to mount the pitch servo with the servo arm further toward the rear of the frame (pictured above).

Place two servo balls on to the pitch servo arm facing inside toward the frame. Attach 2 of the 50mm linkages to the servo arm balls then to the balls on the pitch bellcrank.

View: Top

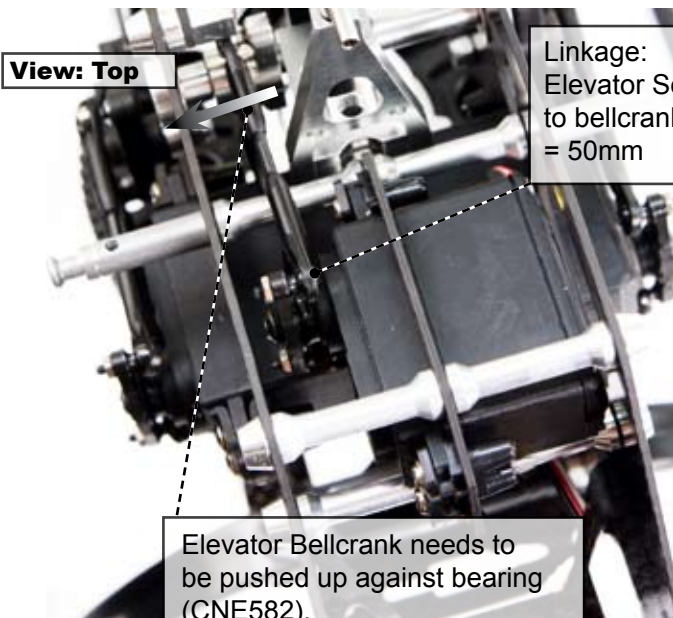

Linkage:
Elevator Servo
to bellcrank(2)
= 50mm

Elevator Bellcrank needs to
be pushed up against bearing
(CNE582).

The aileron servo will mount with a full servo arm on the lower opening of the right side of the main frame. The distance between the steel balls (center of ball) on the servo arm should be 12.5mm. Use the 4 servo screws and 2 servo mounting tabs to mount the aileron servo with the servo arm further toward the rear of the frame (pictured above).

Place two servo balls to the aileron servo arm facing inside toward the frame. Attach 2 of the 50mm linkages to the servo arm balls then to the balls on the aileron bellcrank.

Move the collective stick to its maximum position and watch for any roll (aileron) or pitch (elevator) inputs. If an input is found, the problem will be one of the following in the table. The table describes the symptom and the steps to correct them.

8. Installing and Adjusting Control Components

CCPM Servo Guidelines

The goal in the end after all the servos are mounted is to have the swashplate sit level or at 90 degrees to the main shaft and have the swashplate move equally fore, aft and side to side. The swashplate will also travel up and down as the three servos work together. This will result if the previous instructions have been followed and the ATV function for the three CCPM servos has been set very, very accurately to eliminate pitch change when moving the aileron or elevator sticks.

View: Left Side

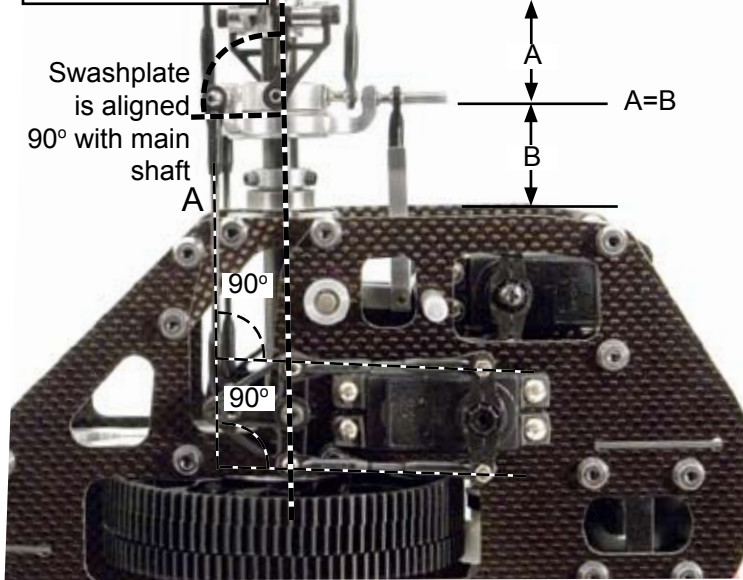

After installing the three cyclic pushrods, the swashplate should sit level.

Move the collective stick to its maximum position and watch for any roll (aileron) or pitch (elevator) inputs. If an input is found, the problem will be one of the following in the table. The table describes the symptom and the steps to correct them.

Symptom	Corrective Solution
metal control ball distance	move ball location to match other servos, or carefully use ATV
angle of horn & servo not 90°	set radio to 0%, place horn on, if not 90, take off and turn until it is.
angle of horn & linkage not 90°	adjust pushrod until set exactly parallel to bellcrank/
swashplate is not level	adjust pushrod A length to level

Setting Up the Rudder Servo

The Rudder Servo Pushrod changes the pitch of the tail rotor blades to increase or decrease the torque compensation to rotate the nose of the helicopter about the main shaft.

Use a servo horn in the shape of a cross and trim the 3 of the 4 arms off. The Rudder Servo Pushrod has a preset length from the factory. Use the 4 Servo screws and 2 servo mounting tabs to mount the servo with the servo output facing the forward right side of the helicopter (pictured to the right). At this point, turn on your radio equipment to center the rudder servo. Attach the servo horn at 90 degrees aligned with the servo.

Use a servo ball on the outside of the servo arm. Attach the front end of the rudder control rod to the servo ball.



Tighten the tail blade grips here

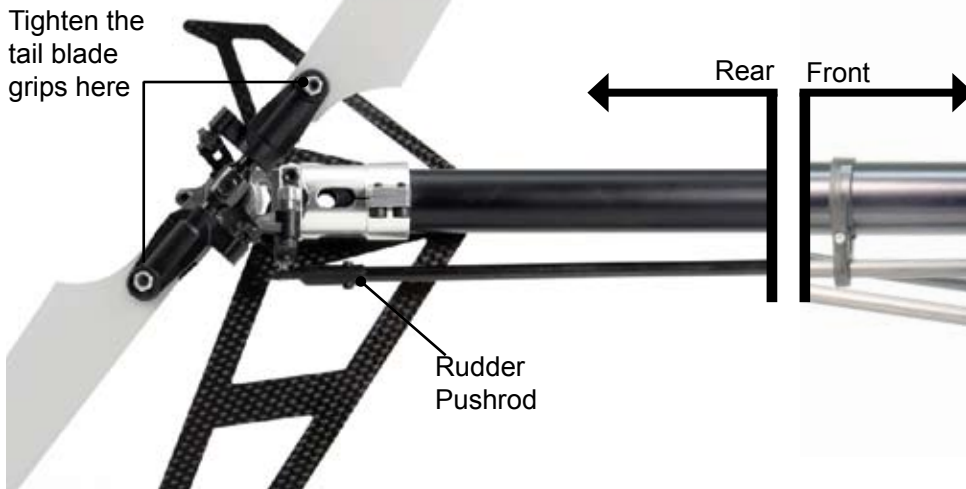

Rudder Pushrod

Servo arm is at a 90 degree angle

8. Installing and Adjusting Control Components

Setting Tail Rudder Pushrod & Blades

1) When setting up the pitch of the tail blades, the tail pitch plate should be first set in the middle position of the tail rotor shaft. The tail blades should have no pitch in that position. Tighten the tail rotor blades until the blade grips hold firm yet soft enough so that the tail blades can still fold back in the event of a blade strike.

2) Adjust the position of the rudder servo bracket so that the tail pitch plate is centered on the tail rotor shaft while the servo arm is at a 90 degree angle.

Hint: Setting zero pitch for tail blades



As the rudder stick is moved to the right, the rudder pushrod will move forward increasing the thrust in the tail blades rotating the nose to the right.

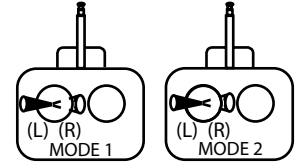

Tail blades will line up in a flat straight line



Mounting Motor and Electronics

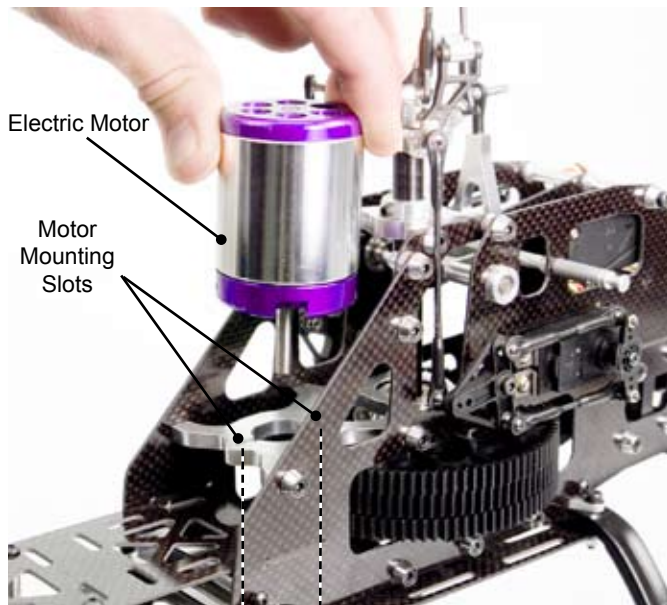

(1) Dry fit the pinion gear to the main motor prior to mounting. Make sure the main motor gear rides in line with the main gear on the Swift. The key to installing the motor is the gear mesh. The elongated slots for mounting the motor allow space to adjust the mesh between the motor pinion gear and the main gear. Install the motor to the motor mounting plate and secure with hardware provided by the manufacturer of the motor.

(2) Install the batteries and control system neatly onto the electronics tray. When installing electronics make sure that wires are not going to come into contact with moving parts. Use foam rubber wrap to wrap the receiver. ** The actual arranged components may be different than the picture illustrates.

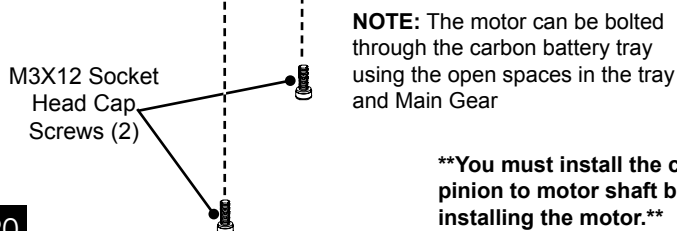

NOTE: The motor can be bolted through the carbon battery tray using the open spaces in the tray and Main Gear

****You must install the correct pinion to motor shaft before installing the motor.****
For details on Motors and Pinions See page 27.

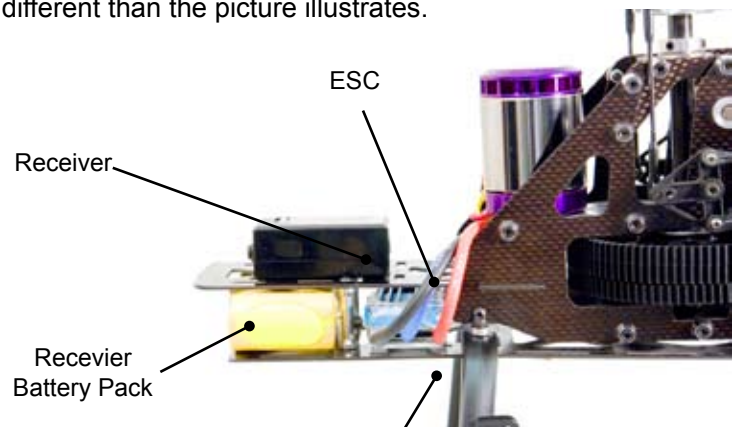

HINT: Installing industrial strength velcro will help secure the batteries during aerobatics.

9. Final Preparations

Mounting the Gyro

The built in Gyro Mounting Plate can be used to mount the gyro at the rear of the helicopter. It is extremely important that the gyro is attached using only the supplied two sided tape onto a clean flat surface. Keep all wires and components away from the gyro housing. Do not use straps or elastics to secure the gyro.

Install the gyro using double sided foam tape (usually supplied with gyro) putting a full strip along the bottom of the gyro unit and press onto the surface. For a good bond make sure both surfaces are clean and dry prior to application



Preparing, Mounting & Tracking The Main Rotor Blades

The Main Rotor Blades are not included in Swift Carbon 620 kit. Please refer to your blades instructions for proper care and storage of your blades. In the event of a crash-landing, discard rotor blades. Scuffs or marks on the blade tips may be the only visible damage however there is no method for inspecting the internal structure of the rotor blades for stress cracks which can cause total blade failure at an unpredictable time. Also, do not store rotor blades indoors in direct sunlight or near heat sources for any period of time. Simply wipe blades clean after each flight.

Blades rotate clockwise, so observe the leading edge. To install the blades, slide the root into the rotor grip and insert one 4mm x 30 Shouldered Socket Cap Screw through the top grip and secure using one 4mm Locknut. Repeat for opposite rotor blade. Blade bolt tension will affect how the blades perform. To set proper tension, start from loose blades (bolt is loose enough for the blade to pivot freely from the grip) and tighten the bolts a little at a time until the blades will hold straight as the helicopter is tipped on its side. Slightly tighter is good. Too tight and a vibration will occur, too loose and a tail boom strike can happen. Tail blades can be set the same way.

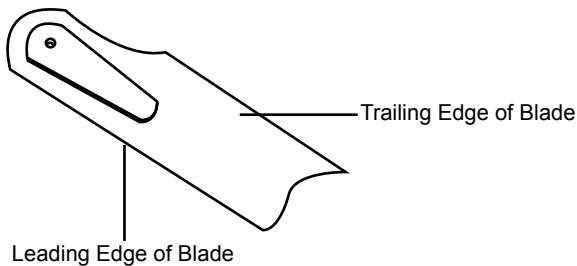

For aerobatic/stunt flight, the Swift Carbon 620 flies best using symmetrical rotor blades. For your convenience you can also use semi-symmetrical for smooth aerobatics and scale flying.

Recommended High Performance Blades & Paddles

CN266001	Rotortech Carbon 600mm Main Blades
CN266166C	Rotortech Carbon 610mm Main Blades
CN260853	Rotortech Carbon 85mm Tail Blades
CN25080	Carbon 80mm Tail Blades
CN262463	Rotortech Carbon Paddles - 19.8g

9. Final Preparations

Preparing, Mounting & Tracking The Main Rotor Blades

(1) The Swift Carbon 620 does not come with main rotor blades. Please refer to the instructions included with your blades (must be purchased separately and are not included with the Swift Carbon 620 kit).

(2) Use the 2 M4x30 blade bolts and M4 locknuts to secure the blades to the blade grips on the main rotor head. Main rotor blades should have their leading edge turning clockwise.

IMPORTANT NOTE: MAIN BLADES AND FLYBAR PADDLES TURN CLOCKWISE.



Balance is the most important part in maintaining a safe and reliable helicopter. First check the blades for balance, this can be done on a blade balancer.

(Optional Item) CN2052 Accuratech v.2 Main Blade Balancer.

Tracking Adjustment

(3) Tracking refers to trimming the actual pitch of the main rotor blades to be equal. On the first flight, bring the rotor head up to speed without leaving the ground and look at the side or profile of the rotor disk (FROM A VERY SAFE DISTANCE, MAKING SURE TO WEAR EYE PROTECTION).

(4) Only one rotor blade should be visible, if there are two distinctive blades then the tracking linkage must be changed. Observe which blade is tracking above the other by marking one first. Track that blade lower by shortening the 'bell mixer to swashplate' linkage rod.



ASSEMBLY COMPLETE! MODELER IS RESPONSIBLE FOR COMPLETENESS AND SAFETY OF THE MODEL.

10. Setup and Adjustment

Final Adjustments - Radio Setup

Now that the servo installation into the helicopter is finished the following pages should be reviewed. As various types of radios can be used to setup the helicopter, some of the following information may not apply.

Servo Direction (Servo Reversing)

Check that all servos move in the correct directions.

Dual Rates

For beginners (using flybar weights, or optional beginner paddles Part #HI3179) the dual rate values should be set as follows:

Normal position: (high rate) 100%
Switch position 1: (low rate) 75%

Exponential

The exponential function allows adjustment of how sensitive the cyclic controls are when the machine is hovering. It is recommended that a negative amount of expo is applied to make the heli more precise in the hover.

Pitch & Throttle Curve Adjustments

With today's speed controllers with built in governors, it is recommended that you always fly in idle up with a flat throttle curve at about 90%

Pitch Curve Adjustment

The following chart shows the values for the collective pitch measured in degrees which are made on the helicopter using a pitch gauge. The Travel Adjustment function (if available makes these settings easy).

For the beginner it is recommended to set the low stick position to 0 degrees to avoid damaging the helicopter while reducing the power during the first few flights. These settings will need slight adjustments to keep the helicopter at a consistent height at mid stick.

Pitch Curve Values by Degrees

Flight Mode	Setup Method	Low Pitch (Low Stick)	Hovering (Mid Stick)	High Pitch (High Stick)
N	Beginner	-5	0	10
1	Stunt & Aerobatics	-7	0	10
2	3D**	-10	0	10
H	Auto-rotation	-11	0	11

(N - Normal flight mode, 1 - Stunt mode one, 2 - Stunt mode two, H - Throttle hold-autorotation)

Setting up eCCPM

General guideline in setting up eCCPM

1. Power up radio and center both sticks. (Tip: add a point above and below the center point of the pitch curve and change them to 50% to widen the "center and zero" portion of the pitch curve for easier reference BUT BE SURE TO REMOVE THEM BEFORE FLIGHT)
2. Place servo horns on all 3 cyclic/pitch servo's as close to 90° to the pushrod as possible.
3. Using a square, straightedge, or other means use the radio SUBTRIM to fine tune servo positions to ensure they are exactly 90° to the pushrod. Once the subtrims are set, do not adjust them again as this is the reference neutral position.
4. Now align the swash to be perfectly centered and leveled on the mainshaft (left/right and fore/aft tilt) using a swash leveling tool or something similar. If it is off fore/aft or left/right adjust the swash pushrods accordingly but DO NOT adjust subtrim.
5. Once the swash is perfectly centered/leveled at mid stick it is time to set END POINTS/ATV's.
6. Move the stick to full collective and again check to see if the swash is perfectly leveled. If it is not adjust the end points of the specific servo that is offering too much or too little travel (tip: leave the elevator servo at 100% both directions and adjust just the pitch/ail servo's to keep a reference center). The adjustment amounts should not exceed 6-7% or you may have different sized arm lengths on the servo's.
7. Move the stick to low collective and again check to see that it is perfectly leveled. If it is not adjust the end point of the specific servo that is offering too much or too little travel.
- 8: Go back and remove the two extra points from the pitch curve from Step 1.

If you need to trim your heli for neutral flight do so with the trim sliders but DO NOT ADJUST SUBTRIMS.

You can now fine tune any interaction by doing the following:

1. Trim the heli for neutral hovering.
2. Do a few full collective climb outs and note if the heli pitches fore/aft or left/right.

If there were pitch changes note the direction and go back to the ATV screen to fine tune the cyclic servo travel. (example: Heli pitches back when full collective is applied, either add a few percent to the full stick elevator travel or reduce both aileron/pitch servo travel) Only change a few percent at a time and do several climb outs before adjustments to ensure it is not environmental changes causing the pitch changes.

- 3: Do a few full negative inverted climb out and note the same as above. Make adjustments on the LOW stick side instead of HIGH stick side.

11. Final Preparations

Final Adjustments - Tail Rotor Setup

What separates airplane radio equipment from the helicopter version is in the control of the individual curves discussed earlier and in the Revo-mixing*.

Take a moment to consider the helicopter hovering in front of you.

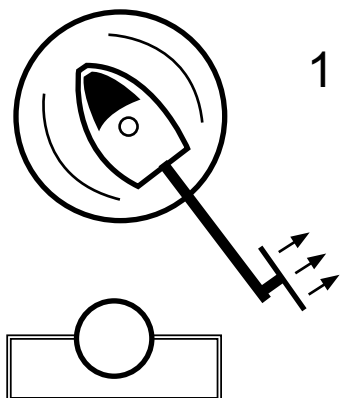

1 Nose rotates left at hover

Problem: Not enough pitch in tail rotor to match torque setting of motor.

Action: Increase pitch by shortening the rudder push-rod.

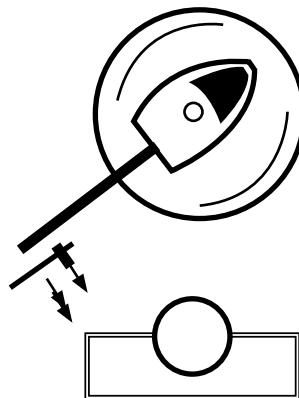

2 Nose rotates right at hover

Problem: Too much pitch in tail rotor to match torque setting of motor.

Action: Decrease pitch by lengthening the rudder push-rod.

Gyro Gain Adjustment

The gyro assists in holding the tail rotor, actually compensating for changes in wind direction or quick movements.

First check that the gyro is installed correctly by watching the rudder servo. While holding the rotor head move the rudder stick to the right and observe the direction the servo arm moves. Now quickly rotate the nose to the left, the servo horn should move in the same direction. If the rudder servo horn moves in the opposite direction reverse the gyro direction.

Generally the starting setting for the gyro gain is 60%, keep increasing the gain setting until the tail starts oscillating back and forth, then reduce the setting slightly.

Problem: Tail rotor makes sudden uncontrolled rotations.

Action: The gyro direction is possibly set in the wrong direction.

Before Flying Your Helicopter

Before each flight, check that all bolts and screws are tight. Simply flying your helicopter, will loosen any screws which are not threadlocked or secured with a lock nut.

First Flights

For the beginner pilot, a training pod is strongly recommended to assist in learning to hover the helicopter with substantially reduced risk of crashing. These systems provide an on ground training capability to allow pilots to become familiar with the helicopter before actually leaving the ground. (Optional Item) Part # CN2007A.

Radio

Always turn the transmitter on first, then turn on your receiver. Before every flight, it is recommended that a range check is performed. This is performed by walking away from your helicopter with the antenna fully collapsed to 30 paces and have someone verify that all control surfaces are operating. If at any time the inputs being provided changes (signaled by the person assisting you), then there may possibly be a communication problem. If you do not make this distance, have an experienced modeler check over your setup and do not fly until doing so.

12. Pre-Flight

Basic Hovering

When all is set, ready and checked, attach your training gear/pod and plug in your battery.

- 1) Place the helicopter pointing into the wind and stand behind the model about 15' away.
- 2) Always watch the nose of the helicopter, move the rudder left and the nose will move left.
- 3) Start by increasing the throttle slowly until the helicopter rises 2-6 inches off the ground then set it back down.
- 4) Repeat this process until you become comfortable with the holding the model in the same spot for a few seconds then land it.

After some time at this you can increase the height slightly up to 1 foot (be very careful not to get too high) as you are practicing taking off and landing. This is the most basic but required skill for the beginner to learn.

Beyond Hovering

It cannot be stressed enough that mastering the hovering skill is crucial to becoming a good helicopter pilot. As you progress in your learning, always practice hovering until you are completely comfortable in holding the helicopter in any direction at any altitude. Perfecting hovering enables you to learn all the types and styles of helicopter flying, forward flight, loops and rolls, 3D (aerobatic flying) and anything you want to do with your Swift helicopter as it can be set up for a beginner through to expert. Lastly, have fun!

Pre-Flight Checklist

- 1) After turning radio on, move each servo separately, looking for unusual or excessive movement.
- 2) Lubricate the main shaft above the swashplate and the pitch slider on the tail output shaft with oil.
- 3) Inspect the main and tail rotor grips for play or binding.
- 4) Turn the main gear in both directions to feel if a problem is developing in the drive train.
- 5) Check the connectors on the battery(s), servos, and receiver to ensure they are still connected.

Pre-Flight Check Up and Trim Adjustments

All trim adjustments are to allow you to lift the helicopter straight up and can be made one click at a time on the radio.

1) Collective & Throttle: Slowly raise the throttle stick, the helicopter should lift off at half stick. If it tends not to lift off increase the hover pitch on the radio or increase the throttle trim. If the helicopter lifts off before mid stick decrease these settings.

2) Rudder: When the helicopter is ready to take off, make a correction trim first then use the rudder stick to control the Left & Right. Note, now is a good time to make a final adjustment on the gyro, see gyro manual.

3) Elevator: If at hover the helicopter tends to move forward, move the trim down, if it moves backward move the trim upwards. Use the elevator stick to control the Forward & Backward.

4) Roll (Aileron): If at hover the helicopter tends to move left, move the trim right, if the helicopter moves to the right move the trim left. Move the Aileron stick to control the slide of the helicopter to the Right & Left.

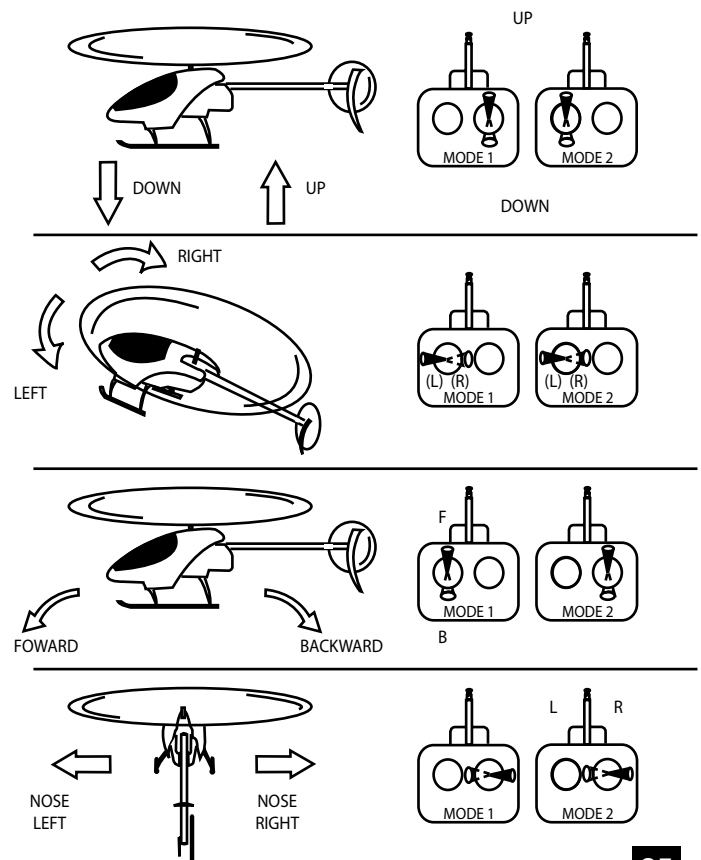

13. Replacement Parts



CNE601
620 Canopy Stand-offs & Grommets



CNE502
CCPM Bellcrank Set



CNE608
620 Solid Main Shaft



CNE610
Main Gear With Auto-rotation Hub



CNE610A
Main Gear Only



CNE510B
Auto-rotation Hub & Bearing Only



CNE511
Upper Shaft Collar



CNE512
Landing Struts



CNE513
Landing Skids



CNE514A
Carbon Fiber Support Frame



CNE518
Seesaw Shaft



CNE564S
CNC Seesaw Spacer



CNE520
Black Rubber Dampeners



CNE521A
Feathering Spindle Reinforced



CNE522
Main Blade Grip Spacers



CNE529
Tail Gear Box Gear With Pin



CNE530
Tail Rotor Shaft



CNE631
620 Tail Drive Belt



CNE632
620 Tail Boom



620 Transmission Gear With Pin



CNE634
620 Rudder Control Rod Set



CNE636
620 Carbon Fin Set



CNE537
Tail Pitch Slider



CNE538
Tail Pitch Lever



CNE542
Tail Transmission Gear Box



CNE643
620 Tail Boom Support Set



CNE544
Tail Servo Mounts



CNE545
Pushrod Set



CNE546
Ball Link Set
(22 Long, 4 Short)



CNE649FP
620 Fiber Glass Canopy

13. Replacement Parts



CNE556
Head Block



CNE556-1
CNC Main Rotor Hub
Only



CNE556-2
CNC Washout Guide



CNE557-1
Main Blade Grip
Only



CNE557-2
Main Blade Grip Arm
Only



CNE558
CNC Bell Mixer



CNE559
CNC Flybar
Control Arms



CNE560
CNC Washout
Arms



CNE561
CNC Machined
Swashplate



CNE563
CNC Machined Motor
Mount



CNE566
CNC Tail Gear Box



CNE567S
CNC Tail Boom Clamp



CNE573
Elevator Carbon Plate



CNE674
620 Carbon Main
Frames
(Left and Right)



CNE675
620 Front Electronics
Tray



CNE677
620 Carbon Gyro
Plate



CNE679
620 Carbon Main
Shaft Supports (2)



CNE580
Metal A-Arm



CNE581
Metal Elevator Bellmixer



CNE582
Elevator Bearings



CNE583
Elevator Arm Spacers



CNE584
Main Frame Brace



CNE585
620 Front Plate Standoffs



CNE586
Short Spacers x6



CNE587
Motor Mount
Spacer (2)



CNE588
Bell Crank
Spacer (2)



CNE589
Elevator Plate Standoffs



CNE590
Transmission Box
Spacer (2)



CNE591
Driven Tail Hub



CNE692
620 Main Gear Hub
Spacer

14. Replacement Parts



CNE593
Upper Bearing Block



CN2217S
Silver Screw Caps
(10)



CNBB364
CCPM Bell Crank
Bearing (4)



CNBB364
Tail Pitch Lever
Bearing (4)



CNBB0730
Seesaw Bearing (2)



CNBB0384
Tail Blade Grip
Bearings (4)



CNBB610
Tail Pitch Slider
Bearing (2)



CNBB614T2
Main Blade Grip
Thrust Bearing (2)



CNBB814
Main Blade Grip
Radial Bearings (2)



CNBB1019
Upper/Lower Bearing
Block Bearing (1)



CNBB364
Bell Mixer Bearing (4)



CNBB1030
Rotor Hub Bearing (2)



CNBB1350
Tail Gear Box
Bearing (2)



CNBB4102
Transmission Gear
Bearing (2)



HI3096B
Tail Blade Grips



HW3098A
Steel Tail Rotor Hub



HI3099
85mm Tail Rotor Blades



HW3173A
4mm Flybar



HI6179
21g Flybar Paddles



CNE551A
620 Decal Set

15. Upgrades/Accessories



CN266001
Rotortech Carbon
600mm Main Blades



CN266166C
Rotortech Carbon
610mm SG 3D Blades



CN266101 Rotortech Car-
bon 615mm Main Blades



CN260853
Rotortech Carbon
85mm Tail Blades



CN262463
RotorTech 3D Carbon
Fiber Paddles



CNMG509
Motor Gear- 9T,
5MM, 1.0



CNMG510
Motor Gear- 10T,
5MM, 1.0



CNMG511
Motor Gear- 11T,
5MM, 1.0



CNMG512
Motor Gear- 12T,
5MM, 1.0



CN2215ASF
Machined Head Button

15. Upgrades/Accessories/Tools



CNE610HE
High Efficiency Main
Gear (Gray)



CNE610AS
Triple Gear Gear
Upgrade Kit



CNE274
Century Outrunner
600A+ 1100kV



CNE275
Century Outrunner
650A+ 800kV



CNE276
Century Outrunner
650A+ 565kV



CN2017
Kryptonite Hex Drivers
M5, M3, M2.5, M2, M1.5



CN2027
G-Force Pitch
Gauge



CN2051
Accuratech Blade
Balancer v.2



CN2050
Paddle Gauge v.2



CND421900Y
Foam Insulator
with Velcro



CN2282S
Metal Tail
Pitch Slider



CN2236
CNC Triple B.B Tail
Assembly



CNE594
Aluminum Washout Hub



CNE480
Electron 80/100
6S ESC



CNE485
Electron 85/110
10S ESC



CNMG509L
Motor Gear- 9T,
5MM, 1.0, Long



CNMG510L
Motor Gear- 10T,
5MM, 1.0, Long



CNMG511L
Motor Gear- 11T,
5MM, 1.0, Long

16. Motors and Pinions

Use this table as a guide, your setup and flight conditions will make these results fluctuate. For ultimate performance with head speeds reaching close to 2000rpm, Century recommends the use of high quality flight packs with at least 20C constant discharge rate.

Motor	4S (14.8V)		5S (18.5V)		6S (22.2V)	
	Pinion	Headspeed	Pinion	Headspeed	Pinion	Headspeed
Century 600A+ (CNE274) RPM/V: 1110	13T	2002	10T	1925	9T	2079
	14T	2156	11T	2118		
Century 650A+ (CNE275) RPM/V: 800	8S (29.6V)		Motor		10S (37.0V)	
	Pinion	Headspeed	Century 650A+ (CNE276) RPM/V: 565		Pinion	Headspeed
	9T	1998	10T	1960		
	10T	2220	11T	2156		

