

DURATRAX

EVADER™ ST



Length: 15.2" [385mm]

Width: 13" [330mm]

Height: 5.8" [147mm]

Weight: 3 lbs 6.3 oz

Wheelbase: 11.6" [295mm]

Motor: Photon Speed™ 20 Turn

Radio: 2-channel surface frequency

ASSEMBLY AND OPERATION MANUAL

Warranty

- **DuraTrax®** will warranty this kit for 90 days after the purchase date from defects in materials or workmanship. DuraTrax will either repair or replace, at no charge, the incorrectly made part.
- Make sure you **save the receipt or invoice** you were given when you bought your model! It is your proof of purchase and we must see it before we can honor the warranty.
- To return your Evader ST for repairs covered under warranty you should send your truck to:

Hobby Services
1610 Interstate Drive
Champaign, Illinois 61822
Attn: Service Department
Phone: (217) 398-0007 9:00 am - 5:00 pm Central Time M-F
E-mail: hobbyservices@hobbico.com

If the buyer is not prepared to accept the liability associated with the use of this product, the buyer is advised to return this kit immediately in new and unused condition to the place of purchase.

**READ THROUGH THIS MANUAL BEFORE STARTING.
IT CONTAINS IMPORTANT INSTRUCTIONS AND
WARNINGS CONCERNING THE ASSEMBLY AND USE
OF THIS MODEL.**

DURATRAX

1610 Interstate Drive Champaign, IL 61822
(217) 398-8970, Ext. 2
carsupport@duratrax.com

TABLE OF CONTENTS

INTRODUCTION.....	2
IMPORTANT SAFETY PRECAUTIONS.....	2
HELPFUL HINTS.....	2
STRESS TECH PARTS GUARANTEE.....	3
REPAIR SERVICE.....	3
SPECIFICATION & DESCRIPTION CHANGES.....	3
REQUIRED ITEMS FOR COMPLETION.....	3
TOOLS NEEDED FOR COMPLETION.....	3
TOOLS INCLUDED FOR MAINTENANCE.....	3
FINISHING THE RTR VERSION.....	4
FINISHING THE PRE-BUILT VERSION.....	5
Preparing the Radio System.....	5
Charge Your Battery.....	5
Steering Servo Installation.....	6
Receiver Installation.....	7
ELECTRONIC SPEED CONTROL SET-UP.....	8
MAINTENANCE TIPS.....	8
Before Each Run.....	8
After Each Run.....	8
After Every Ten Runs.....	8
ASSEMBLY GUIDE.....	9
TUNING GUIDE.....	11
Caster.....	11
Camber.....	11
Front Toe-In and Toe-Out.....	Back Cover
Wheelbase.....	Back Cover
Battery Placement.....	Back Cover
Ride Height.....	Back Cover
Camber Link Placement.....	Back Cover
Slipper Adjustment.....	Back Cover
Front Shock Adjustment.....	Back Cover
Rear Shock Adjustment.....	Back Cover
Shock Oils & Shock Springs.....	Back Cover

INTRODUCTION

Thank you for purchasing the DuraTrax Evader ST. This manual contains the instructions you need to build, operate and maintain your new electric R/C stadium truck. Read over this manual thoroughly before building or operating the Evader ST.

SAFETY PRECAUTIONS

When the safety precautions are followed, the Evader ST will provide years of enjoyment. Use care and good sense at all times when operating this radio controlled stadium truck. Failure to use this vehicle in a safe, sensible manner can result in injury or damage to property. You and you alone must insure that the instructions are carefully followed and all safety precautions are obeyed.

- Do not operate the Evader ST near people. Spectators should be behind the driver or at a safe distance away from the vehicle.
- Make sure to read the instructions with the battery and charger before charging.
- Do not leave the charger unattended during charging. If the battery or charger become hot at any time disconnect the battery from the charger immediately! Failure to do so may cause permanent damage to the charger and battery, and may cause bodily harm.
- Do not cover the air intake holes on the charger during charging, this may cause the charger to overheat.
- Do not allow the electronic speed control (ESC) or radio equipment to come into contact with moisture. Water can cause the electronics to short out and can cause permanent damage.
- Always turn on the transmitter before turning on the electronic speed control.
- Before turning on your radio check to make sure that no one else is running on the same frequency as your Evader ST.

HELPFUL HINTS

- Avoid working over a deep pile carpet. If you drop a small part or screw, it will be difficult to find.
- Place a mat or towel over your work surface. This will prevent parts from rolling off and will protect the work surface.
- Avoid running the truck in cold weather. The plastic and metal parts can become brittle at low temperatures. In addition, grease and oil become thick, causing premature wear and poor performance.
- Test fit all parts before attaching them permanently.

STRESS-TECH™ PARTS GUARANTEE

We have engineered the Evader ST to take the rough and tumble abuse that makes R/C stadium trucks fun. We are so confident of the quality and durability of the Stress-Tech plastic parts that we will replace any Stress-Tech plastic part you break during the first 12 months you own the truck. Just send in the part to us and we will send you a FREE replacement. Please see the Evader ST parts list for the items covered under the Stress-Tech guarantee.

To receive your free replacement part please send the following to the Hobby Services address listed on the cover of this manual.

- 1. The broken part must be included.
- 2. The part number and description of the broken part.
- 3. Dated copy of your invoice or purchase receipt.
- 4. Your name, phone number and shipping address.

REPAIR SERVICE

Repair service is available anytime.

- After the 90 day warranty, you can still have your Evader ST repaired for a small charge by the experts at DuraTrax's authorized repair facility, Hobby Services, at the address listed on the front page of this manual.

To speed up the repair process, please follow the instructions listed below.

- 1. Under most circumstances return the ENTIRE system: truck and radio. The exception would be sending in a Stress-Tech part. See the instructions under Stress-Tech Guarantee.
- 2. Make sure the transmitter is turned off, and all of the batteries are removed.
- 3. Send written instructions which include: a list of all items returned, a THOROUGH explanation of the problem, the service needed and your phone number during the day. If you expect the repair to be covered under warranty, be sure to include a proof of date of purchase (your store receipt or purchase invoice).
- 4. Also be sure to include your full return address.

SPECIFICATION & DESCRIPTION CHANGES

All pictures, descriptions and specifications found in this instruction manual are subject to change without notice. DuraTrax maintains no responsibility for inadvertent errors in this manual.

REQUIRED ITEMS FOR COMPLETION



To operate the Evader ST the following items are required:

- DuraTrax 6 cell battery pack (DTXC2065)
- DuraTrax 6-7 cell charger (DTXP4000)

For the pre-built version of the Evader ST, you will also need:

- 2-channel radio with one (1) standard servo (FUTJ24**)
- Eight (8) "AA" batteries (for the transmitter)

TOOLS NEEDED FOR COMPLETION

- Hobby knife (HCAR0105)
- #11 Blades (HCAR0211)
- #2 Phillips head screwdriver (DTXR0124)
- Needle nose pliers (DTXR0300)

TOOLS INCLUDED FOR MAINTENANCE AND CLEANING

- 3/32", 1.5mm & 2.5mm hex Wrenches
- Turnbuckle wrench
- Nut driver (4-way)

FINISHING THE EVADER ST RTR VERSION (DTXD20**)

- ❑ 1. Remove the Evader ST and radio system from the box.
- ❑ 2. Charge the (not included) 6 or 7 cell battery on the (not included) charger. **See Safety Precautions before charging and charge the battery according to the instructions that came with your charger.**

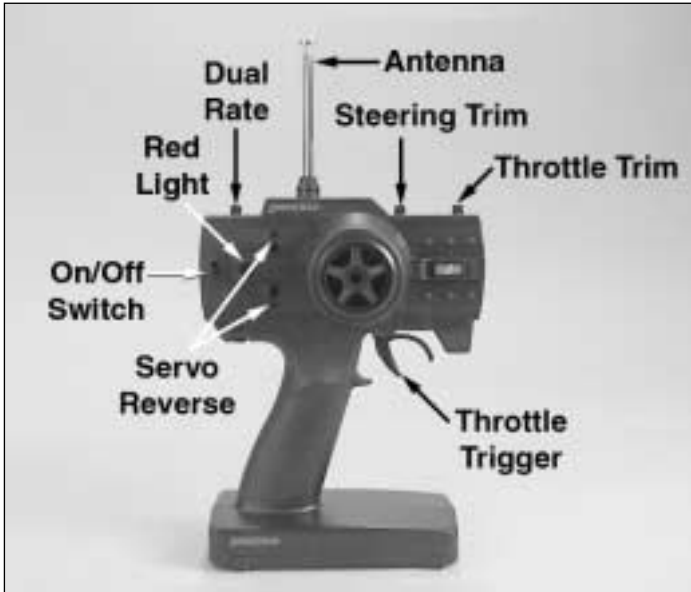

- ❑ 3. Install the transmitter antenna by screwing it into the hole on the top of the transmitter.



- ❑ 4. Slide open the battery door on the bottom of the transmitter. Install eight (8) "AA" batteries into the transmitter in the configuration molded into the plastic on the battery holder. Re-install the battery door.
- ❑ 5. Turn on the transmitter using the on/off (see step 3). The red light on the transmitter should light up. If there is no light on, turn the transmitter off and check to ensure that the batteries are making contact with the metal contacts in the battery holder. Make sure the batteries are installed correctly. Turn the transmitter on and check for the red light. If the red light appears, turn off the transmitter. If the red light blinks, the batteries are low and should be replaced.

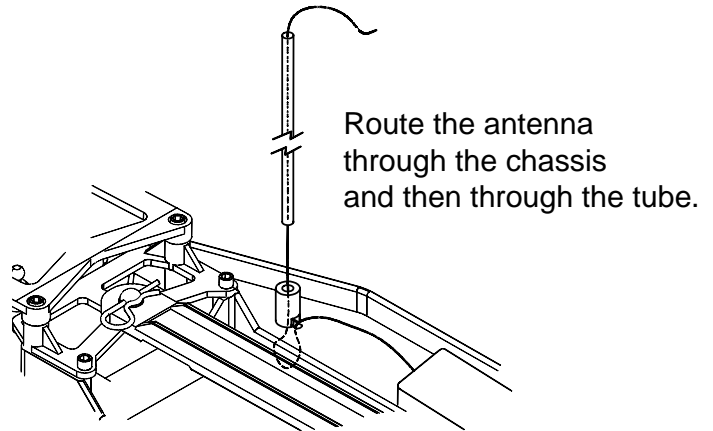

- ❑ 6. Straighten the receiver antenna. Route the receiver antenna through the holes in the chassis as shown above. Locate the antenna tube, and thread the receiver antenna through the antenna tube. The antenna will be longer than the antenna tube. **DO NOT CUT OR COIL THE ANTENNA WIRE.** Press fit the antenna tube into the hole in the chassis. **Tip: Run the antenna wire through your fingers to straighten out the kinks before running through the antenna tube. Also, applying a small amount of soap and water to the antenna wire will help lubricate the wire for threading into the antenna tube.**

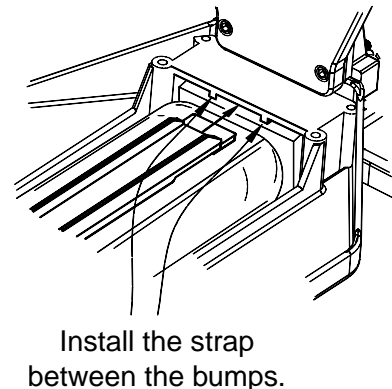
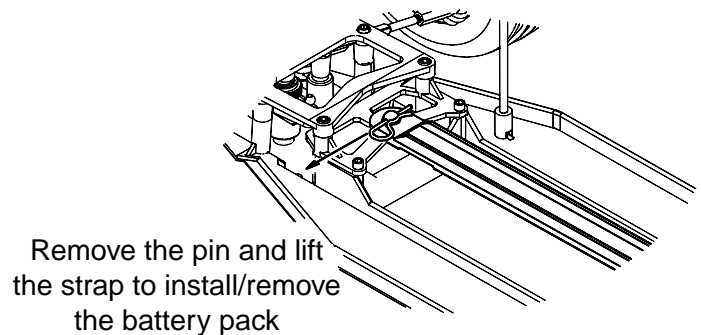

- ❑ 7. Remove the body pin from the battery strap post, and remove the battery strap from the Evader ST.



□ 8. Install the charged 6 or 7 cell battery into the battery slot. Re-install the battery strap onto the Evader ST. **Note that there is a channel in the chassis for the battery strap to rest in.** Re-install the body clip into the battery strap post.

□ 9. The transmitter features a dual rate knob labeled “D/R” on the top of the transmitter. Turning it fully clockwise will give you the greatest amount of steering travel. Turning it

counterclockwise will reduce the amount of steering travel. If you are just learning to drive R/C you may want to use less steering travel at first.



□ 10. Decal the body as desired.

□ 11. Proceed to page 8 for **Maintenance Tips**.

FINISHING THE EVADER ST PRE-BUILT VERSION (DTXC0020)

PREPARING THE RADIO SYSTEM

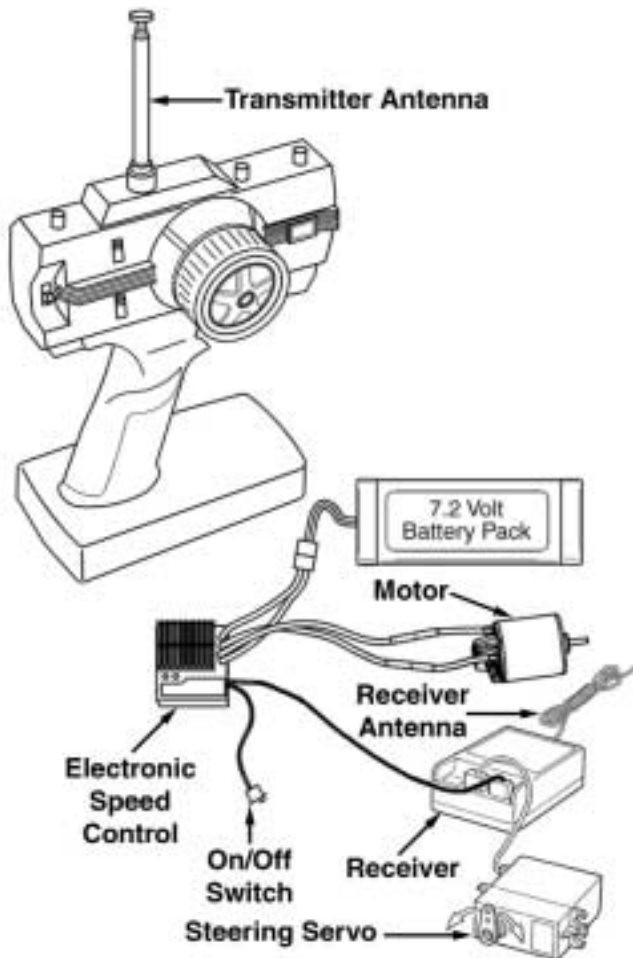

- 1. Install the “AA” batteries in the transmitter.
- 2. Install and extend the transmitter antenna.
- 3. Connect the steering servo and electronic speed control to the receiver.
- 4. Uncoil and extend the receiver antenna.
- 5. Hook up the charged 6 or 7 cell battery to the electronic speed control.
- 6. Adjust the servo trims of the transmitter to the neutral position.
- 7. Switch on the transmitter.
- 8. Switch on the electronic speed control.
- 9. Operate the steering and throttle control. Make sure the steering servo arm and motor move in proportion to the movement of the steering wheel and throttle trigger.
- 10. Switch off the receiver, then the transmitter.

CHARGE YOUR BATTERY



- 1. Charge the 6 or 7 cell battery (not included) on your charger (not included). **See Safety Precautions before charging.**

STEERING SERVO INSTALLATION

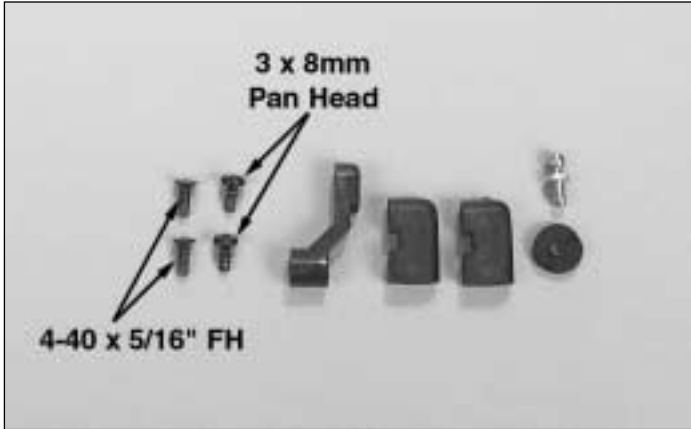

□ 1. Locate and remove from the parts bag two (2) steering servo mounts, one (1) servo arm (determine which servo arm is required for your radio system), one (1) 4-40 ball stud, one (1) foam washer, two (2) 3x8mm pan head screws and two (2) 4-40 x 5/16" flat head machined screws. To ensure that you are using the right size screw, match the screw to the picture on the hardware chart.



□ 2. Attach the servo mounts to the servo using the two (2) 3x5mm screws as shown.



□ 3. Install the 4-40 ball stud into the flat side of the steering servo arm in the upper hole. With the steering servo centered as described in "Preparing the Radio System", install the correct steering servo arm onto the servo splines as shown above. (Note: If the steering servo is not properly centered, the steering could be off). Re-install the servo horn screw, securing the horn onto the servo.

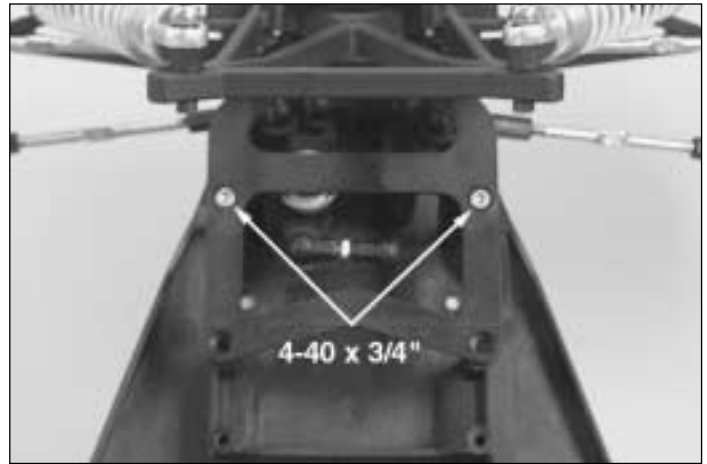

□ 4. Remove the two (2) 4-40 x 3/4" socket head machined screws from the upper plate and rotate the front of the truck forward. (Note: Be careful that you do not loosen any of the steering assembly parts during this process).

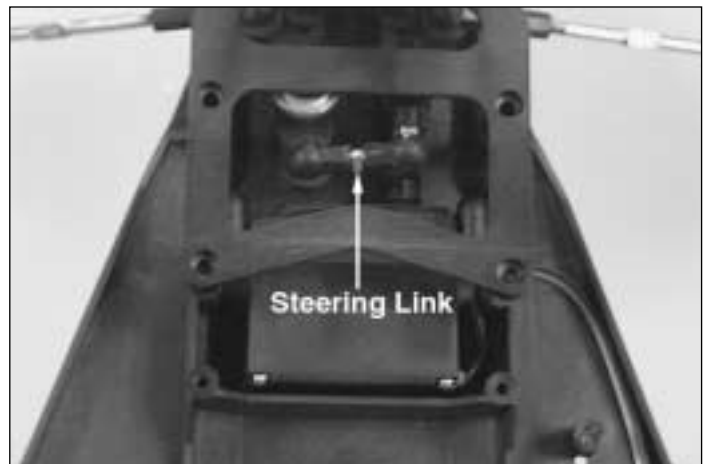
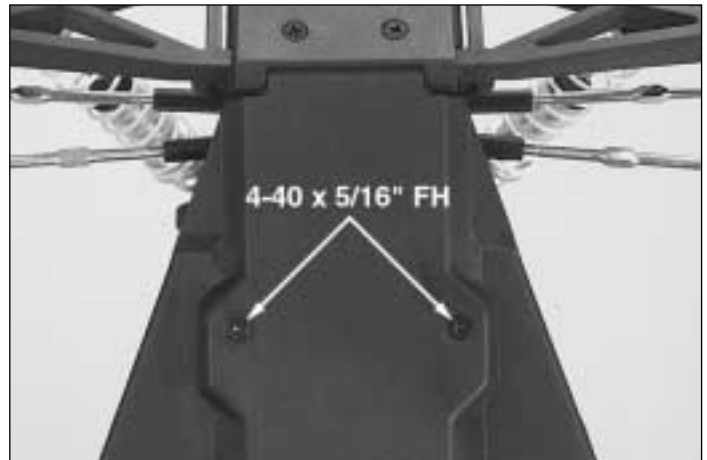

□ 5. Install the steering servo into the mounting slot. Line up the holes in the servo mounts with the two holes in the chassis. (Note: there are two different mounting holes in the servo mounts. Use the appropriate holes for your servo). Install the two (2) 4-40 x 5/16" flat head machined screws through the bottom of the chassis into the servo mounts. Attach the steering link ball cup onto the 4-40 ball stud on the servo.



- 6. Install the servo brace onto the chassis using the two (2) 4-40 x 3/8" socket head machined screws and two (2) 4-40 x 3/4" socket head cap screws. Re-install the two (2) 4-40 x 3/4" socket head cap screws into the upper plate.

RECEIVER INSTALLATION

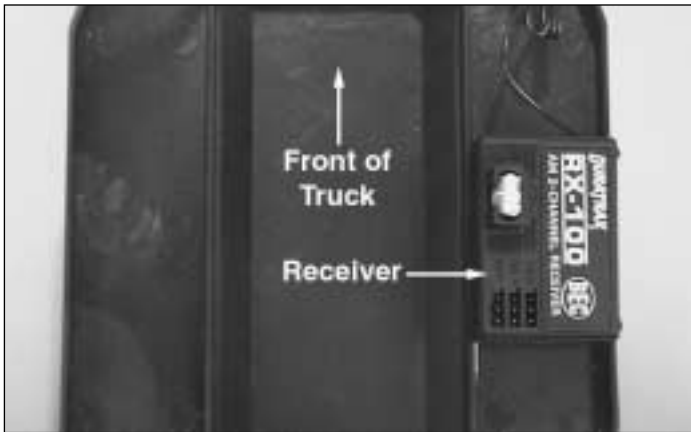

- 1. Install the receiver onto the chassis as shown. Remove the protective backing from one side of the included 1/4" thick piece of foam tape and install it onto the chassis. Then remove the other piece of protective backing and install the receiver onto the foam rubber.

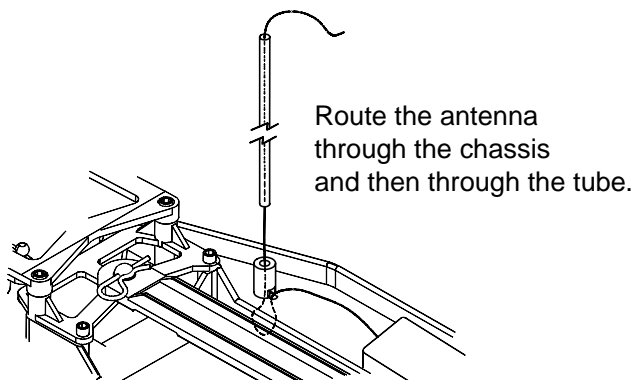

- 2. Route the receiver antenna through the holes in the chassis as shown above. Locate the antenna tube, and thread the receiver antenna through the antenna tube. The antenna will be longer than the antenna tube. **DO NOT CUT OR COIL THE ANTENNA WIRE.** Press fit the antenna tube

into the hole in the chassis. **Tip: Run the antenna wire through your fingers to straighten out the kinks before running through the antenna tube. Also, applying a small amount of soap and water to the antenna wire will help lubricate the wire for threading into the antenna tube.**

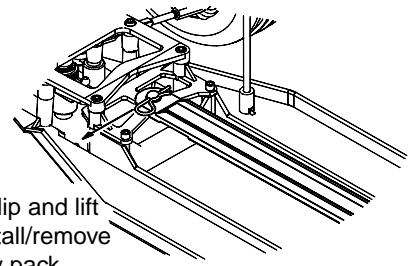

Remove the clip and lift the strap to install/remove the battery pack

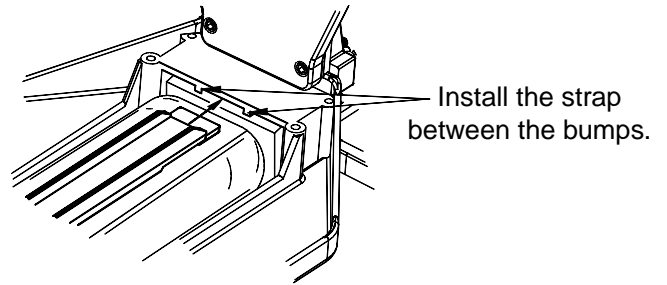

Install the strap between the bumps.

- 3. Remove the body pin from the battery strap post, and remove the battery strap from the Evader ST.



- 4. Install the charged 6 or 7 cell battery into the battery slot. Re-install the battery strap onto the Evader ST. **Note that there is a channel in the chassis for the battery strap to rest in.** Re-install the body clip into the battery strap post.



- 4. Decal the body if desired.

ELECTRONIC SPEED CONTROL SET UP

NOTE: The Sprint electronic speed control is pre-set at the factory. The following instructions should be followed if the pre-set needs to be changed. During normal running, the speed control should be switched “on” and not given input from the transmitter for 2 seconds. This bypasses the set-up stage of the ESC.

Note: The set-up portion of the Sprint ESC occurs in the first 2 seconds when the speed control is turned on.

- 1. Set the throttle trim of the transmitter at neutral.
- 2. Turn the transmitter on.
- 3. Turn the electronic speed control on.
- 4. Squeeze the throttle trigger all of the way and hold it for 2 seconds.
- 5. Push the throttle trigger to full reverse and hold it for 2 seconds.
- 6. Return the throttle trigger to neutral. The green LED should turn on after a few seconds.
- 7. The speed control will hold this setting until it is reset.
- 8. If the speed control did not set-up, repeat the steps.

MAINTENANCE TIPS

BALL DIFFERENTIAL BREAK-IN

The ball differential has been adjusted at the factory for proper “break-in”. Do not tighten the differential before the truck has been properly broken-in or you can damage the differential.

After running the truck for 2 or 3 battery packs, the ball differential will require readjustment. This is the “normal” break-in period for the ball differential. You will hear a “squealing” sound when accelerating from a stop and the truck will accelerate slower. This indicates that the differential is properly broken-in and now requires adjustment. Do not run the truck until the differential is properly readjusted as follows.

Adjusting the differential is quick and easy. Access the adjusting screw by disconnecting the rear camber link (using pliers) at the right rear wheel. Rotate the wheel and universal joint out of the way.

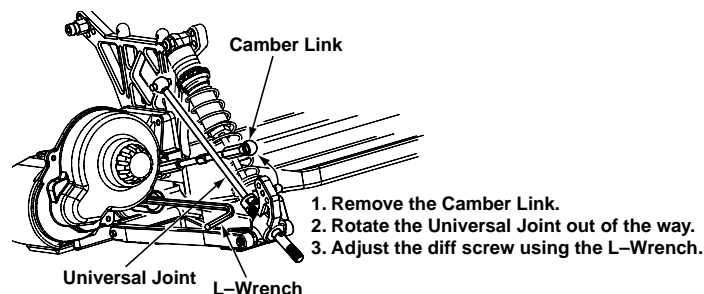

While holding the left rear tire, tighten the adjusting screw by inserting the included L-wrench into the cap screw on the right side of the ball differential. The screw should be

tightened until it is “just snug.” **Caution:** Do not over tighten the adjusting screw or you will damage the differential. Next, loosen the screw 1/8 of a turn.

Reinstall the universal shaft back into the differential and reattach the camber link. The ball differential may need occasional adjustment to maintain performance.

BEFORE EACH RUN

- 1. Check to make sure that all screws are tight and there are not any screws missing.
- 2. Check to make sure that the transmitter batteries are not low.
- 3. Check to make sure that all of the moving parts of the Evader move freely and do not bind.
- 4. Check for broken or damaged parts. Replace any broken or damaged parts before running the Evader ST. Running of the Evader ST with broken or damaged parts could result in damage to other parts.
- 5. Check to make sure that the receiver and speed control are still properly secured to the chassis.
- 6. Check to make sure that all wires are properly connected.

AFTER EACH RUN

- 1. Clean any large globs of dirt or debris from the chassis and moving parts.
- 2. Disconnect and remove the battery from the Evader.
- 3. Check for any broken or damaged parts. This way parts may be replaced before the next run.

AFTER EVERY 10 RUNS

- 1. The servo saver is factory set. During normal maintenance, check its operation by grasping the servo arm and linkage and turning one of the front tires left and right. If the wheels turn without moving the linkages and servo arm then the unit is operating properly. If the linkage and servo arm move, loosen the knurled adjustment nut on the left side servo saver shaft. If the servo saver becomes clogged with dirt, it may not work properly which could cause servo or linkage damage. The servo saver needs to be disassembled, cleaned and readjusted. To safely adjust the servo saver, loosen the knurled aluminum collar on the left side steering post completely. Then reinstall 1½ turns onto the post. Retest the servo saver as described above. Adjust the servo saver tighter or looser if needed.
- 2. Check to make sure that the bearings are free of dirt and debris, and roll smoothly.
- 3. Check the shocks for oil leakage. If the shocks have leaked any shock fluid out, you should properly refill the shocks for best performance. Inspect the shock shafts for deep scratches.
- 4. Check the motor brushes for wear. If the motor brushes are severely worn or discolored they should be replaced.
- 5. Check for buildup and wear on the bushings of the motor. If the bushings are dirty, use DuraTrax Power Shot to clean them. If the bushings are worn, replace the motor.
- 6. Make sure the servo saver is free moving and does not bind. This will help prevent stripping of the servo during running.
- 7. Check for smooth gear mesh between the spur and pinion gear.

ASSEMBLY GUIDE

The following information has been provided to help maintain and tune the Evader ST.

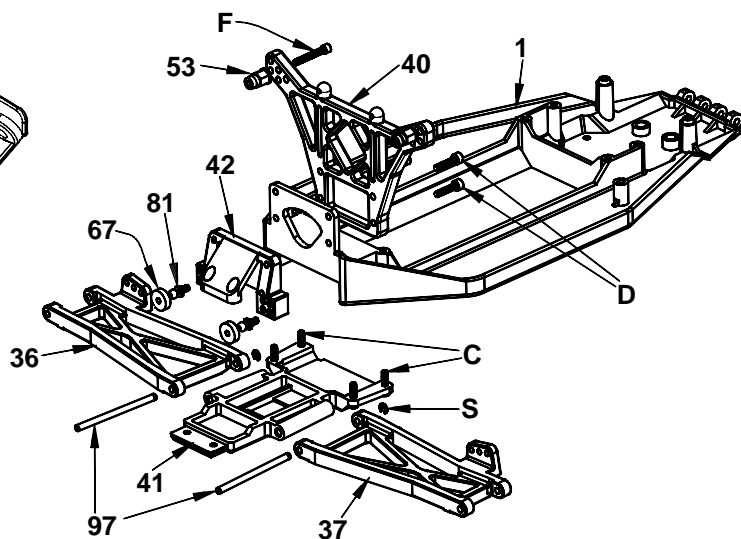
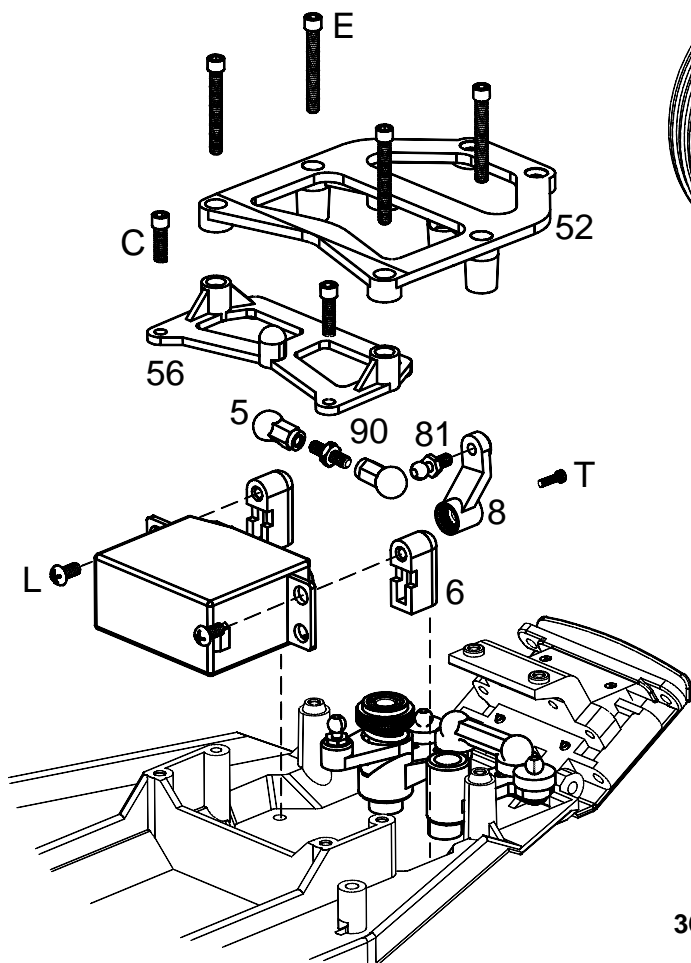
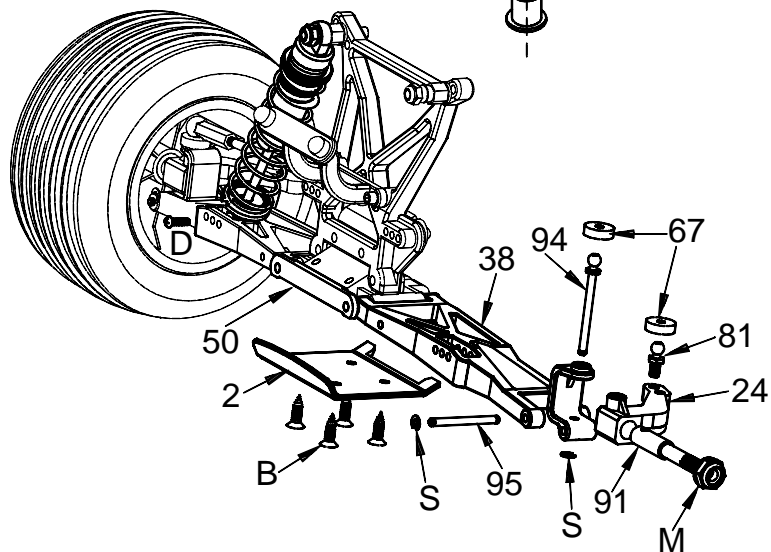
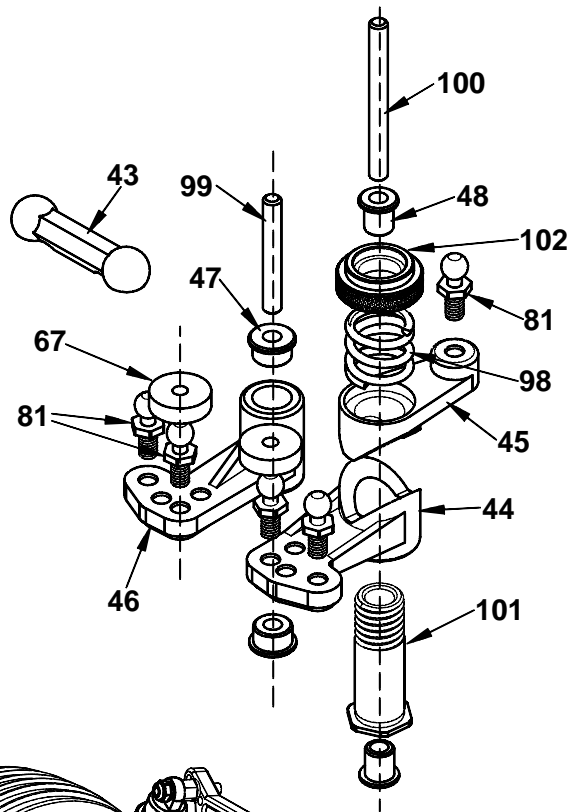
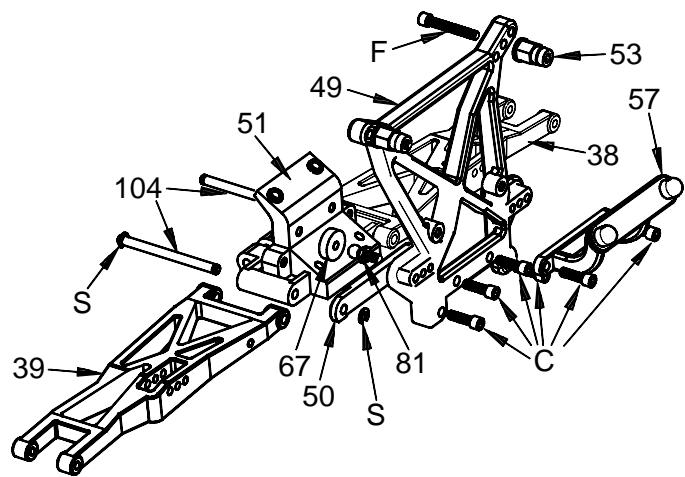

The diff can be properly adjusted by tightening the diff bolt until snug and then back off 1/8 turn.

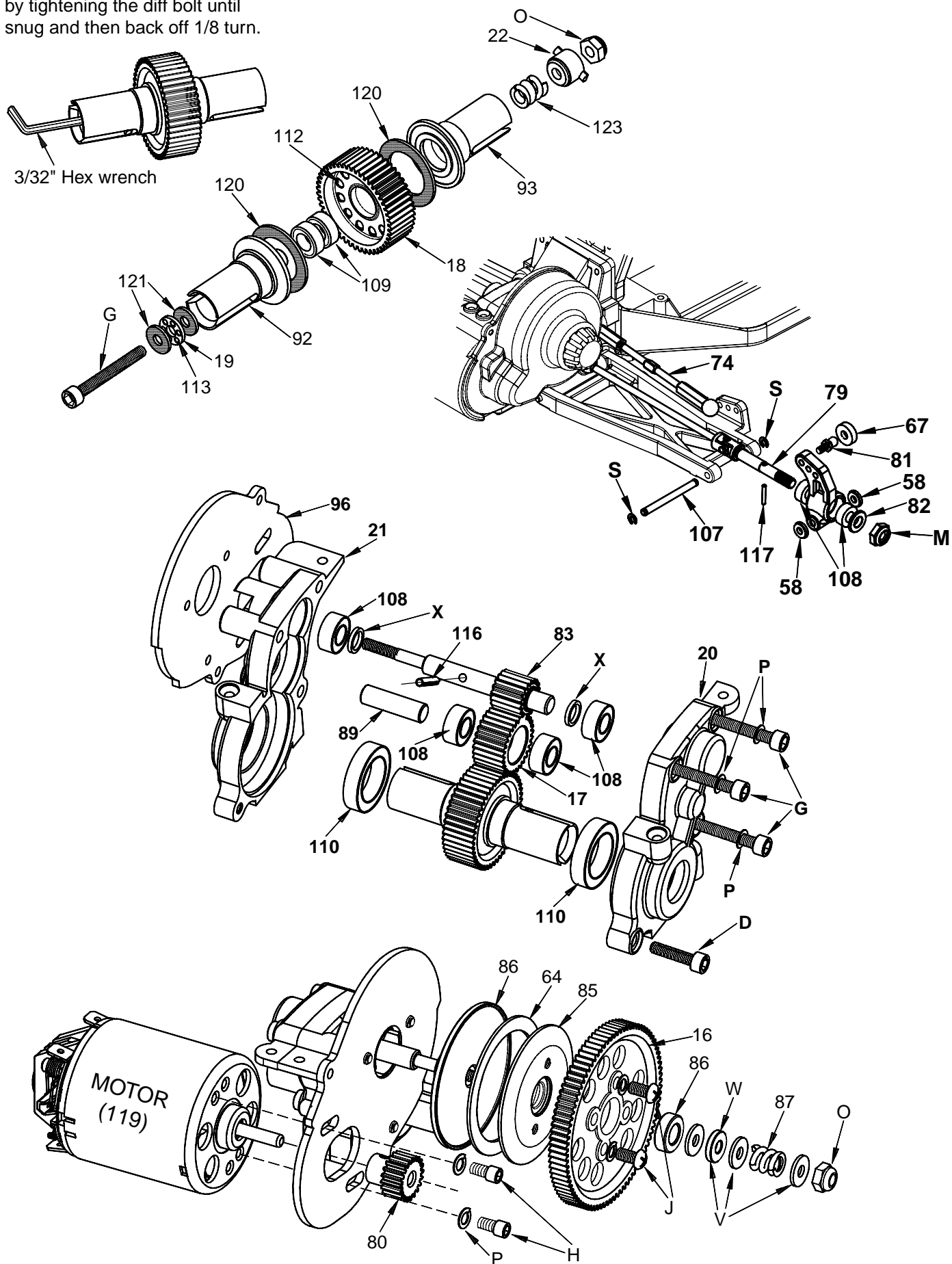

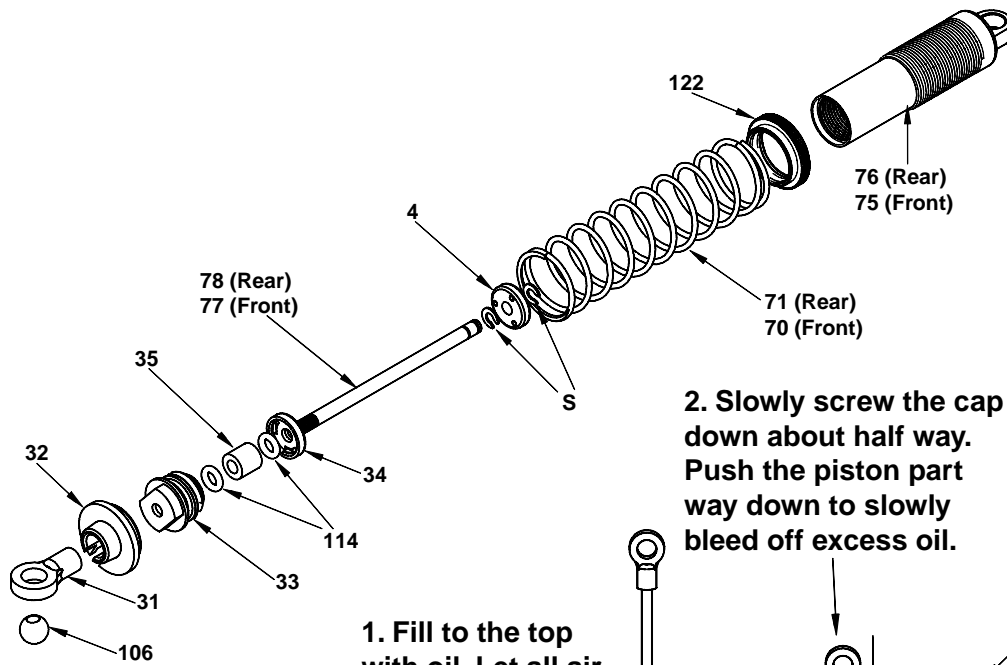

1. Fill to the top with oil. Let all air bubbles rise to the top before assembly.

2. Slowly screw the cap down about half way. Push the piston part way down to slowly bleed off excess oil.

3. Tighten the cap a little more and push the piston down the rest of the way.

4. Finally, tighten the cap all the way.

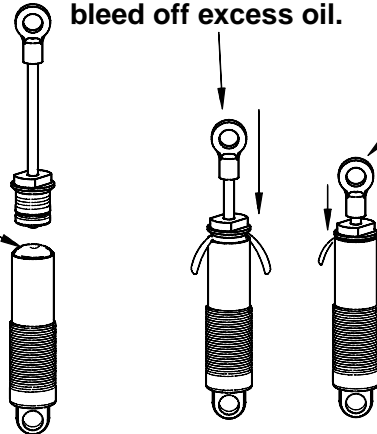

With a properly filled shock, the piston can be pushed in completely and will then rebound about 3/8". Exercise the shock a few times and listen for air bubbles. If you hear any squishing, rebuild the shock.

TUNING GUIDE

When tuning the Evader ST make sure that you have equal length shocks on both sides (left and right), camber rods and steering rods. Also, make sure to have the shock pre-load adjusters at the same setting from left to right. They do not have to be the same front to rear.

CASTER

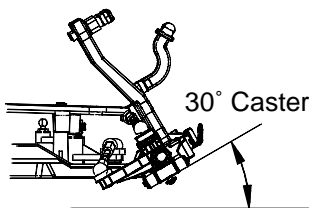

Caster refers to the angle at which the kingpin is at in relation to the surface when viewed from the side. 0 degrees of caster means that the kingpin is straight up and down. The Evader comes stock with 30 degrees of caster and is not adjustable.

CAMBER

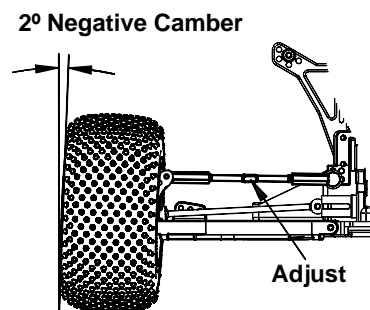

Camber refers to the angle at which the tire and wheel ride in relation to the ground when viewed from the front or rear. Negative camber is when the tire and wheel lean inward and positive camber is when the tire and wheel lean outward. Typically you want 0 to 2 degrees of negative camber. Never put in positive camber. Make sure that both sides have equal amounts of camber by keeping the camber turnbuckles equal in length.

FRONT TOE-IN AND TOE-OUT

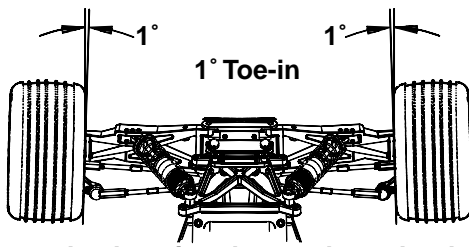

Front wheels pointed towards each other

Toe-in and toe-out refers to the angle at which the tire is at when viewed from above. Toe-in increases stability under acceleration. However, toe-in also decreases steering when entering a corner. Toe-out will increase steering into corners, but will decrease the overall stability during acceleration. The front typically is set-up with 0 to -2 degrees of toe-in.

Rear toe-in affects the traction of both the front and rear of the truck. Rear toe-in increases the amount of traction in the rear, but decreases steering. Decreasing rear toe-in will increase steering, but will give less rear traction. The Evader comes pre-set with 3 degrees of rear toe-in.

WHEEL BASE

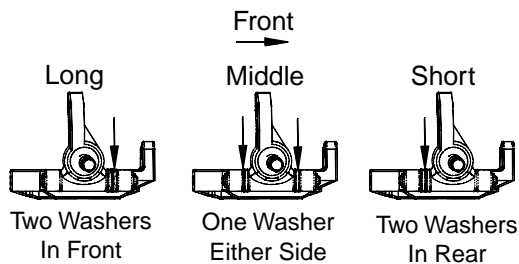

Wheel base is the distance from the center of the front wheel to the center of the rear wheel. By lengthening the wheel base of the Evader it increases steering, but decrease rear traction as a result of increase weight distribution to the front wheels. Decreasing the wheel base of the Evader will increase rear traction, but decrease steering.

BATTERY PLACEMENT

The battery placement of the Evader can be adjusted with the foam spacers which will affect the trucks rear traction. Spacing the battery in the forward position will create less rear traction. Spacing the battery in the rear position will create more rear traction.

RIDE HEIGHT

The ride height of the Evader ST effects how it jumps and handles. The ride height of the Evader ST is adjustable through the threaded pre-load adjusters on the shock bodies. To measure the ride height of the Evader, set the truck up as if you are ready to run. Push the front of the truck down all of the way and release it. When the truck returns the front arms should be parallel with the surface. The rear ride height is set

up the same except that the drive shafts are parallel with the surface. Lowering the front ride height will increase steering response due to more weight on the front wheels. Lowering the rear ride height will increase rear traction and reduce steering response due to more weight on the rear wheels.

CAMBER LINK PLACEMENT

The camber link placement affects the traction and handling on rough tracks. By using a long mounting position, it will increase traction but decrease stability. By shortening the link, it will increase stability, but decrease traction.

SLIPPER ADJUSTMENT

The slipper clutch is designed to help prevent gear breakage during jumping and controls traction. The slipper should not be over tightened, this could cause damage to the differential gears. The slipper should be set so that it slips for 1-2 feet from a stop with a fully charged battery.

FRONT SHOCK ADJUSTMENT

Moving the tops of the shocks out will increase steering and quicker suspension reaction. Moving the tops of the shocks in will result in slower steering reaction, but will be smoother over bumps. Mounting the bottoms of the shocks in the inside hole will give more slow speed steering but will take away some high speed steering.

REAR SHOCK ADJUSTMENT

Moving the tops of the shocks in will result in more traction in the corners and will be smoother over the bumps. Moving the tops of the shocks out will give the truck more steering and handle large jumps better.

SHOCK OILS AND SHOCK SPRINGS

Many different combinations can be used between the shock oils and shock springs. Some basic guidelines when setting up the Evader are that if the rear end is stiff it will give the truck more steering and have less rear traction. Hardening the front will result in less steering and more rear traction. (Changing the position of the threaded shock pre-load adjusters results in ride-height change. It does not change the spring tension). Thinner shock oil make the shocks react faster, but makes the truck less stable and may cause the truck to bottom out over large jumps. Thicker shock oil makes the truck smoother over large jumps and in straights, but less reactive over rough sections. We have filled the shocks with 20 weight shock oil, which is a good choice for most driving conditions.

STEERING DUAL RATE

Adjust the dual rate knob to increase or decrease the steering travel. When first learning to drive, adjust the dual rate knob for less steering travel. As you get to be a better driver, adjust the dual rate knob for more steering travel.