

12Z

12 CHANNEL RADIO CONTROL SYSTEM
PCMG3/PCM1024/FM selectable

INSTRUCTION MANUAL



TABLE OF CONTENTS

INTRODUCTION	4	●Registration of the user's name	24
●Support and Service	4	●Home screen	25
●Application, Export, and Modification	5		
●Definitions of Symbols.....	6	FUNCTIONS OF SYSTEM MENU	27
●Safety Precautions (do not operate without reading)	6	Trainer.....	28
		Display	30
BEFORE USE	9	Sound.....	31
●Features of 12Z	9	System Timer	32
●Contents and technical specifications	10	User Name.....	33
●Accessories.....	11	H/W Reverse	35
●Transmitter controls.....	12	Information	36
Cautions on handling antenna	12		
LED monitor	13	MODEL BASIC SETTING PROCEDURE ...	37
Switch (SA-SH).....	13	●Airplane/gliders basic setting procedure.....	37
Volume (LD, CD, RD).....	14	●Helicopter basic setting procedure.....	39
Slide Lever (LS, RS).....	14	●Receiver and servos connection.....	43
Digital trim (T1-T4)	14	●Servo connection by model type.....	44
Edit key	15		
Stick Adjustment	15	FUNCTIONS OF LINKAGE MENU	48
CF card.....	17	(Common Functions)	
Connector/Plug.....	18	Linkage Menu functions table	48
Attachment and detachment of the battery.	18	Servo Monitor.....	49
RF module MZ-FM.....	19	Model Select.....	50
●Receiver nomenclature.....	20	Model Type.....	52
●Safety precautions when installing receiver and servos	21	Frequency.....	54
		Function	55
		Sub-Trim	57
		Servo Reverse	58
		Fail Safe.....	59
BASIC OPERATION	22	End Point (ATV).....	60
●Battery Charging	22	Throttle Cut (Airplane/helicopter only).....	61
How to charge the Lithium Ion Battery	22	Idle Down (Airplane/helicopter only).....	62
How to charge the Ni-Cd Battery	22	Swash (Helicopter only).....	63
●How to turn On/OFF the transmitter	23	Timer	65
When turning on	23	Dial Monitor	66
When turning off.....	23	Data Reset	67
●How to change the frequency/How to set the receiver's ID	23	Condition Hold switching (Helicopter only)	68
●In case of using PCM1024, PPM receivers... ..	24		

FUNCTIONS OF MODEL MENU

●Common Functions	69	●Helicopter Functions	106
Servo Monitor (Linkage Menu 49)		Model Menu functions list.....	106
Condition Select.....	70	PIT Curve/Pit trim.....	107
AFR (D/R).....	72	THR Curve/Throttle hover trim.....	110
Program Mix.....	74	Acceleration	112
Fuel Mixture	77	Throttle Hold	113
●Airplane/Glider/EP Glider Functions.....	78	Swash Mix.....	114
Model Menu functions list.....	78	Throttle Mix.....	115
AIL Differential	80	PIT to Needle	116
Flap Setting.....	81	PIT to RUD (Revolution mix)	117
AIL to Camber FLP.....	82	Fuel Mixture (Common functions 77)	
AIL to Brake FLP.....	83	Gyro (for GY type gyro)	118
AIL to RUD.....	84	Governor	119
Airbrake to ELE.....	85	●Common Operations used in function setup	
RUD to AIL.....	87	screen	120
Camber Mix.....	88	●T12Z software updating procedure	127
ELE to Camber	90		
Camber FLP to ELE	91		
Butterfly	92		
Trim Mix 1/2	94		
Airbrake.....	96		
Gyro (for GYA type gyro).....	98		
V-tail	99		
Ailevator.....	100		
Winglet.....	101		
Motor.....	102		
RUD to ELE.....	103		
Snap Roll.....	104		
Multi Engine	105		

INTRODUCTION

Thank you for purchasing the Futaba® 12Z series digital proportional R/C system. In order for you to make the best use of your system and to fly safely, please read this manual carefully. If you have any difficulties while using your system, please consult the manual, our online Frequently Asked Questions (on the web pages referenced below), your hobby dealer, or the Futaba Service Center.

Due to unforeseen changes in production procedures, the information contained in this manual is subject to change without notice.

Support and Service: It is recommended to have your Futaba equipment serviced annually during your hobby's "off season" to ensure safe operation.

IN NORTH AMERICA

Please feel free to contact the Futaba Service Center for assistance in operation, use and programming. Please be sure to regularly visit the 12Z Frequently Asked Questions web site at <http://www.futaba-rc.com/faq/faq/index.html>. This page includes extensive programming, use, set up and safety information on the 12Z radio system and is updated regularly. Any technical updates and US manual corrections will be available on this web page. If you do not find the answers to your questions there, please see the end of our F.A.Q. area for information on contacting us via email for the most rapid and convenient response.

Don't have Internet access? Internet access is available at no charge at most public libraries, schools, and other public resources. We find internet support to be a fabulous reference for many modelers as items can be printed and saved for future reference, and can be accessed at any hour of the day, night, weekend or holiday. If you do not wish to access the internet for information, however, don't worry. Our support teams are available Monday through Friday 8-5 Central time to assist you.

FOR SERVICE ONLY

Futaba Service Center
3002 N. Apollo Drive, Suite 1
Champaign, IL 61822
Phone: 217-398-0007
service@futaba-rc.com

FOR SUPPORT

(PROGRAMMING AND USER QUESTIONS)

Please start here for answers to most questions:
www.futaba-rc.com
FACSIMILE: 217-398-7721
PHONE: 217-398-8970 option 2

OUTSIDE NORTH AMERICA

Please contact your Futaba importer in your region of the world to assist you with any questions, problems or service needs. Please recognize that all information in this manual, and all support availability, is based upon the systems sold in North America only. Products purchased elsewhere may vary. Always contact your region's support center for assistance.

Application, Export, and Modification

1. This product is suitable for model airplane, surface or 50 MHz (license required) use, if on the correct frequency. It is not intended for use in any application other than the control of models for hobby and recreational purposes. The product is subject to regulations of the FCC and is restricted under United States law to such purposes.

2. Exportation precautions:

(a) When this product is exported from the country of manufacture, its use is to be approved by the laws governing the country of destination which govern devices that emit radio frequencies. If this product is then re-exported to other countries, it may be subject to restrictions on such export. Prior approval of the appropriate government authorities may be required. If you have purchased this product from an exporter outside your own country and not the authorized Futaba distributor in your country, please contact the seller immediately to determine if such export regulations have been met.

(b) Use of this product with other than models may be restricted by Export and Trade Control Regulations, and an application for export approval must be submitted. In the US, use of 72MHz (aircraft only), 75MHz (ground models only) and 27MHz (both) frequency bands are strictly regulated by the FCC. This equipment must not be utilized to operate equipment other than radio controlled models. Similarly, other frequencies (except 50MHz, for HAM operators) must not be used to operate models.

3. Modification, adjustment, and replacement of parts: Futaba is not responsible for unauthorized modification, adjustment, and replacement of parts on this product. Any such changes may void the warranty.

The Following Statement Applies to the Receiver (for U.S.A.)

This device complies with part 15 of the FCC rules. Operation is subject to the following two conditions:

- (1) This device may not cause harmful interference.
- (2) This device must accept any interference received, including interference that may cause undesirable operation.



The RBRC™ SEAL on the nickel-cadmium battery contained in Futaba products indicates that Futaba Corporation of America is voluntarily participating in an industry-wide program to collect and recycle these batteries at the end of their useful lives, when taken out of service within the United States. The RBRC program provides a convenient alternative to placing used nickel-cadmium batteries into the trash or municipal waste system, which is illegal in most areas.

You may contact your local recycling center for information on where to return the spent battery. Please call 1-800-8-BATTERY for information on battery recycling in your area. Futaba Corporation of America's involvement in this program is part of its' commitment to protecting our environment and conserving natural resources.

NOTE: Our instruction manuals encourage our customers to return spent batteries to a local recycling center in order to keep a healthy environment. RBRC is a trademark of the Rechargeable Battery Recycling Corporation.

Definitions of Symbols

Pay special attention to safety where indicated by the following symbols.

 **DANGER** – Procedures which may lead to dangerous conditions and cause death/serious injury if not carried out properly.

 **WARNING** – Procedures which may lead to a dangerous condition or cause death or serious injury to the user if not carried out properly, or procedures where the probability of superficial injury or physical damage is high.

 **CAUTION** – Procedures where the possibility of serious injury to the user is small, but there is a danger of injury, or physical damage, if not carried out properly.

 = **Prohibited**

 = **Mandatory**

Warning: Always keep electrical components away from small children.

FLYING SAFETY

To ensure the safety of yourself and others, please observe the following precautions:

 **Have regular maintenance performed.** Although your 12Z protects the model memories with non-volatile EEPROM memory (which does not require periodic replacement) and not a battery, it still should have regular checkups. We recommend sending your system to the Futaba Service Center annually during your non-flying season for a complete checkup and service.

 **Use the *Fail-Safe* safety feature to set the throttle to *low-idle* in case of signal loss or RX battery failure.** Engine power will be automatically reduced to help limit personal or property damage. Refer to the **Failsafe Setting Procedure** listed in the index.

Receiver Ni-Cd Battery

 **Charge the batteries!** (See **Charging the batteries** listed in the index for details.) Always recharge the receiver batteries for at least 8 hours before each flying session. A low battery will soon die, causing loss of control and a crash. When you begin your flying session, reset your timer, and during the session pay attention to the duration of usage.

CAUTION: The **initial** charge on **new** NiCd receiver batteries should be done for 15 hours **using the slow-charger that came with the radio system**. This will “condition” the batteries so that the next charge may be done using the fast-charger of your choice. If the initial charge is done with a fast-charger the batteries may not reach their full capacity and you may be flying with batteries that are only partially charged.

Where to Fly

We recommend that you fly at a recognized model airplane flying field. You can find model clubs and fields by asking your nearest hobby dealer, or in the US by contacting the Academy of Model Aeronautics. You can also contact the national Academy of Model Aeronautics (AMA), which has more than 2,500 chartered clubs across the country. Through any one of them, instructor training programs and insured newcomer training are available. Contact the AMA at the address or toll-free phone number below.

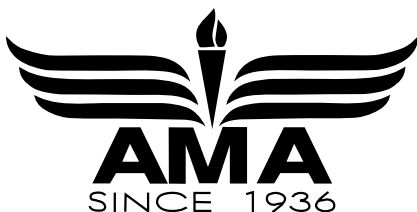

Academy of Model Aeronautics

5151 East Memorial Drive

Muncie, IN 47302-9252

Tel. (800) 435-9262

Fax (765) 741-0057

or via the Internet at <http://www.modelaircraft.org>

Lithium-ION Battery Safety and Handling instructions

IMPORTANT! The Lithium-Ion (Li-Ion) batteries included in the 12Z transmitter are not to be confused with Lithium-Polymer (LiPo) batteries, or any other type of rechargeable battery (including NiCd's and NiMH's). Li-Ion batteries require special charging criteria different than other rechargeable batteries. Use only the **Futaba** lithium ion transmitter charger included with this set for, or other chargers approved by Futaba to charge the Li-Ion batteries in the 12Z transmitter.

It is important to understand the operating characteristics of lithium-ion (Li-Ion) batteries. Always read the specifications printed on the label of your Li-Ion battery and charger prior to use. Failure to follow the proceeding precautions can quickly result in severe, permanent damage to the batteries and its surroundings and possibly result in a **FIRE!**

IMPORTANT PRECAUTIONS

- ⊘ Do not attempt to disassemble Li-Ion packs or cells.
- ⊘ Do not allow Li-Ion cells to come in contact with moisture or water at any time.
- ⚠ Always provide adequate ventilation around Li-Ion batteries during charge, discharge, while in use, and during storage.
- ⊘ Do not leave a Li-Ion battery unattended at any time while being charged or discharged.
- ⊘ Do not attempt to charge Li-Ion batteries with a charger that is NOT designed for Li-Ion batteries, as permanent damage to the battery and charger could result.
- ⚠ Always charge Li-Ion batteries in a fireproof location. Do not charge or discharge Li-Ion batteries on carpet, a cluttered workbench, near paper, plastic, vinyl, leather or wood, or inside an R/C model or full sized automobile! Monitor the charge area with a smoke or fire alarm, and have a lithium-approved "ABC type" fire extinguisher available at all times.
- ⊘ Do not charge Li-Ion batteries at currents greater than the "1C" rating of the battery ("C" equals the rated capacity of the battery).
- ⊘ Do not allow Li-Ion cells to overheat at any time! Cells which reach greater than 140 degrees Fahrenheit (60°C) should be placed in a fireproof location.
- ⚠ Li-Ion cells will not charge fully when too cold or show full charge.
- ⚠ It is normal for the batteries to become warm during charging, but if the charger or battery becomes excessively hot disconnect the battery from the charger **immediately!!** Always inspect a battery which has previously overheated for potential damage, and do not re-use if you suspect it has been damaged in any way.
- ⊘ Do not use a Li-Ion battery if you suspect physical damage has occurred to the pack. Carefully inspect the battery for even the smallest of dents, cracks, splits, punctures or damage to the wiring and connectors. **DO NOT** allow the battery's internal electrolyte to get into eyes or on skin—wash affected areas immediately if they come in contact with the electrolyte. If in doubt, place the battery in a fire-proof location for at least 30 minutes.
- ⊘ Do not store batteries near an open flame or heater.
- ⊘ Do not discharge Li-Ion batteries at currents which exceed the discharge current rating of the battery.
- ⚠ Always store Li-Ion cells/packs in a secure location away from children.

Compact Flash (CF) Card Handling Instructions

Follow these precautions when handling the CF card (Optional)

- ⊘ Never remove the CF card or turn off power while entering data.
- ⊘ Never store the CF card where it may be subject to strong static electricity or magnetic fields.
- ⊘ Do not expose the CF card to direct sunlight, excessive humidity or corrosive environments.
- ⊘ Do not expose the CF card to dirt, moisture, water or fluids of any kind.
- ⚠ Always hold the CF card by the edges during installation and removal.
- ⚠ Be certain to insert the CF card in the correct direction.
- ⚠ Always use Futaba CF card.

AT THE FLYING FIELD

- ❗ **Always pay particular attention to the flying fields' rules**, as well as the presence and location of spectators, the wind direction, and any obstacles on the field. Be very careful flying in areas near power lines, tall buildings, or communication facilities as there may be radio interference in their vicinity. If you must fly away from a club field, be sure there are no other modelers flying within a three-to-five-mile range, or you may lose control of your aircraft or cause someone else to lose control.
- ❗ **Before flying, be sure that the frequency you intend to fly with is not in use**, and secure any frequency control device (pin, tag, etc.) for that frequency before turning on your transmitter. It is never possible to fly two or more models on the same frequency at the same time. Even though there are different types of modulation (AM, FM, PCM), only one model may be flown on a single frequency at any one time.
- ❗ **Stop flying long before your batteries become low on charge**. Do not rely on your radio's low-battery warning systems, which are intended only as a precaution, to tell you when to recharge. **Always check your transmitter and receiver batteries prior to each flight.**
- ❗ To prevent possible damage to your radio gear, turn the power switches on and off in the proper sequence:
 1. Set the throttle stick to the idle position, or otherwise disarm your motor/engine.
 2. Fully extend the transmitter antenna.
 3. Turn on the transmitter power and allow your transmitter to reach its home screen.
 4. Confirm the proper model memory has been selected.
 5. Turn on your receiver power.
 6. Test all controls. If a servo operates abnormally, don't attempt to fly until you determine the cause of the problem. (For PCM systems only: Test to ensure that the Failsafe settings are correct by waiting at least 2 minutes after adjusting then, turning the transmitter off and confirming the proper surface/throttle movements. Turn the transmitter back on.)
 7. Start your engine.
 8. Complete a full range check.
 9. After flying, bring your throttle stick to idle position, engage any kill switches or otherwise disarm your motor/engine.
 10. Turn off receiver power.
 11. Turn off transmitter power.

If you do not turn on your system in this order, you may damage your servos or control surfaces, flood your engine, or in the case of electric-powered or gasoline-powered models, the engine may unexpectedly turn on and cause a severe injury.

- ❗ **While you are getting ready to fly, if you place your transmitter on the ground, be sure that the wind won't tip it over**. If it is knocked over, the throttle stick may be accidentally moved, causing the engine to speed up. Also, damage to your transmitter may occur.
- ❗ **Before taxiing, be sure to extend the transmitter antenna to its' full length**. A collapsed antenna will reduce your flying range and cause a loss of control. It is a good idea to avoid pointing the transmitter antenna directly at the model, since the signal is weakest in that direction.
- ⊘ **Don't fly in the rain!** Water or moisture may enter the transmitter through the antenna or stick openings and cause erratic operation or loss of control. If you must fly in wet weather during a contest, be sure to cover your transmitter with a waterproof barrier. Never fly if lightning is expected.
- ⊘ **Never turn the transmitter off during flight!** Switching the transmitter off and on during flight will very likely cause a crash because of the time required for the transmitter to "reboot" and become fully functional.

BEFORE USE

FEATURES

PCMG3 (PCM Generation 3)

PCMG3 has a 40% faster response than current PCM1024. The resolution is 2048, which is double the current PCM1024. It can operate up to 12 Channels. The multi-level modulation technology has been implemented for the R/C industry to achieve the highest performance available today.

WFSS (Wireless Frequency Setting System)

The construction of both transmitter (T12Z) and receiver (R5014) are a frequency synthesizer system.

Model types

Seven types of main wings and three types of tail wings are available for airplanes. Seven swash types are available for helicopters. Seven types of main wings and three types of tail wings are available for gliders. Functions and mixing functions necessary for each model type are set in advance at the factory.

Mixing functions

The T12Z transmitter continues the functions of the higher class model T14MZ and meets the need for precise setting at meets, etc. by use of abundant curve mixing functions

Data input

Large graphic LCD and new type edit keys substantially improve ease of setup. Omni directional cursor lever, rotating data input dial which allows quick data input, and two kinds of return key are provided

Stick

Each axis is supported by dual ball bearings. This allows for finer and more precise operation, the new potentiometers also offer longer life.

Li-ion battery

T12Z is operated by 7.4V/2,200 mAh Lithium-Ion battery.

R5014DPS

The R5014DPS is a small 14CH synthesized receiver with high sensitivity and selectability.

CF (Compact Flash) card (Optional)

Model data can be saved in an optional Futaba CF card (CFDP32M, etc.) When T12Z transmitter software updating files are released, the software can be updated by using a CF card.

Contents and Technical Specifications

(Specifications and ratings are subject to change without notice.)

Your 12ZA/12ZH/12Z (packaged with a 14-channel PCM-G3 receiver) includes the following components:

- T12Z Transmitter, including RF module (MZ-DDS)
- R5014 Receiver
- LT2F2200 Li-ion battery & LBC-1D5 Charger
- NR4F1500 Ni-Cd battery & Charger (except for Australia)
- Switch harness/DSC cord
- Hex Wrench (1.5mm, 2.5mm)
- Neck strap

The set contents depend on the type of set.

Transmitter T12ZA/T12ZH/T12Z

Operating system: 2-stick, 12 channels, PCM-G3, synthesizer system

Transmitting frequency: 29, 35, 36, 40, 41, or 72 MHz bands

Modulation: PCM-G3, PCM1024, or FM/PPM switchable.

Power supply: 7.4V LT2F2200 Li-ion battery

Current drain: 500mA average

Receiver R5014DPS

(PCM-G3, Synthesizer, Dual conversion)

Receiving frequency: 29, 35, 36, 40, 41, or 72 MHz bands

Intermediate freq.: 10.7 MHz & 450 kHz

Power requirement: 4.8 V Ni-Cd battery

Current drain: 75 mA

Size: 52x37.5x16.5 mm

Weight: 33 g.

Channels: 14

Suggested Servos for use with your 12Z

Servo S9154 (Digital servo)

Control system: Pulse width control, 1.52 ms neutral

Power requirement: 4.8 V (from receiver)

Output torque: 63.9 oz.-in. (4.6 kg-cm) at 4.8V

Operating speed: 0.14 sec/60 at 4.8V

Size: 1.87 x 1.06 x 0.97 in. (47.5 x 27.0 x 25.3 mm)

Weight: 1.87 oz. (53 g)

Servo S9255 (Digital servo)

Control system: Pulse width control, 1.52 ms neutral

Power requirement: 4.8 V (from receiver)

Output torque: 125.0 oz.-in. (9.0 kg-cm) at 4.8V

Operating speed: 0.16 sec/60 at 4.8V

Size: 1.57 x 0.79 x 1.44 in. (40.0 x 20.0 x 36.6 mm)

Weight: 1.94 oz. (55 g)

The following additional accessories are available from your dealer. Refer to a Futaba catalog for more information:

- Compact Flash Memory card - CFDP 32M Data-Pack increases your model file storage capability, and allows you to transfer model settings to another T12Z transmitter.
- LT2F2200 Transmitter battery pack - the (2200mAh) transmitter Li-ion battery pack may be easily exchanged with a fresh one to provide enough capacity for extended flying sessions.
- Trainer cord - the optional training cord may be used to help a beginning pilot learn to fly easily by placing the instructor on a separate transmitter. Note that the T12Z transmitter may be connected to another T12Z system, as well as to any other models of Futaba transmitters. The T12Z transmitter uses the newer “Micro” rectangular type cord plug. Both Micro- to-Micro and Micro-to-round plug style trainer cords are available.
- Neckstrap - a neckstrap may be connected to your T12Z system to make it easier to handle and improve your flying precision since your hands won’t need to support the transmitter’s weight.
- Y-harnesses, servo extensions, etc - Genuine Futaba extensions and Y-harnesses, including a heavy-duty version with heavier wire, are available to aid in your larger model and other installations.
- Gyros - a variety of genuine Futaba gyros are available for your aircraft or helicopter needs.
- Governor (GV1) - for helicopter use. Automatically adjusts throttle servo position to maintain a constant head speed regardless of blade pitch, load, weather, etc.
- DSC Cord - allows setup and testing without transmitting. With your Transmitter and Receiver off, plug cord into trainer port then, into the receiver Battery/DSC (B/C) slot. All programming and setup may be done in this manner without transmitting.
- Receivers - various models of Futaba receivers may be purchased for use in other models. (Receivers for PCM-G3, PCM1024, or FM/PPM types are available.)
- Optional Charger - Futaba CR-2500 Li-Ion Transmitter/Receiver Battery Charger.

Transmitter controls

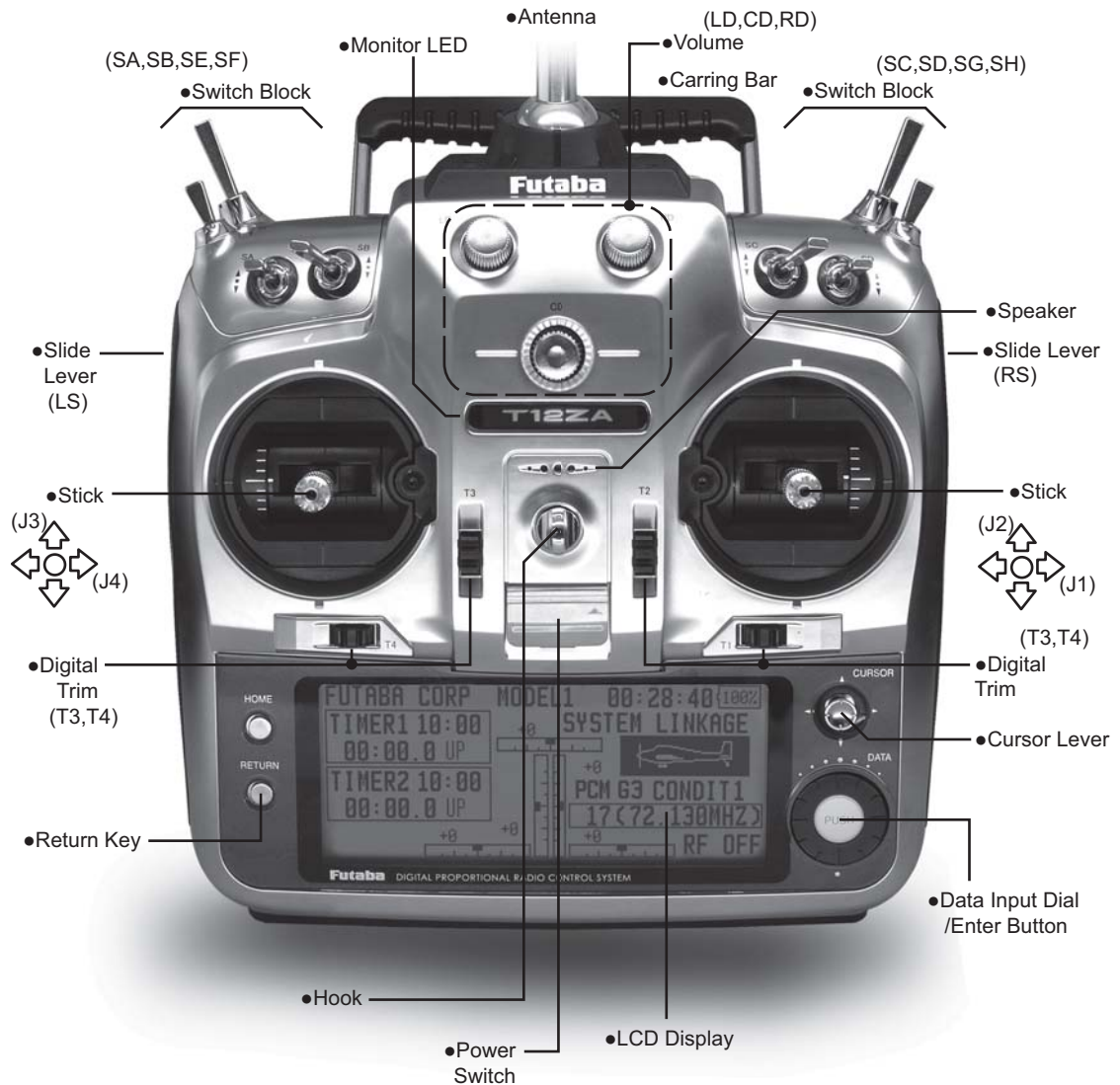

Cautions on handling antenna

⚠ WARNING

❗ Be sure to attach the antenna before operation.

*Antenna is stored in the antenna storage box in the transmitter.

❗ Extend the antenna to the full extent, and make sure that the antenna is securely locked before operation.

⊘ Never hold the antenna alone.

*Hold the carrying bar, otherwise the main body can be damaged.

•Removing and storing the antenna

When removing the antenna from the antenna compartment, hold the transmitter level so that the antenna will not fly out and fall, then push the antenna eject button.

When storing the antenna, push the antenna in until it is locked positively

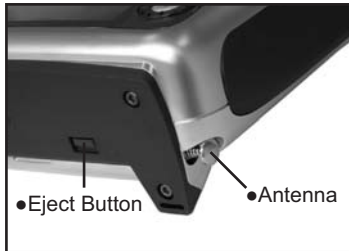

•Mounting and dismounting the antenna

Mount the antenna by turning it clockwise until it locks in place.

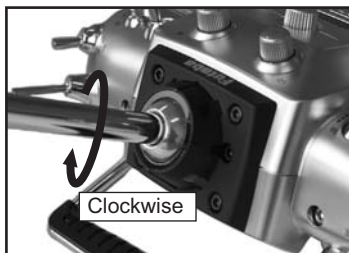

- When dismantling the antenna, turn the antenna counterclockwise

•Angle adjustment of the antenna

You can change the angle of the antenna, as you like. Use 2.5mm hexagonal wrench to turn counterclockwise to release the screw on the left of the antenna holder, and change the angle of the antenna, as you like, then retighten.



LED monitor

The color of the 12Z logo mark shows the status of the transmitter.



(LED Display)

- When you turn on the transmitter, 12Z logo shows different colors, and then the color stays constantly pink. The 12Z logo blinks green very rapidly while internal processing is carried out after the power is turned on. Once the internal processing is over, the logo turns to pink color.
- The 12Z logo turns blue when you use the DSC cable, or when the trainer function is set at student's side.
- The 12Z logo blinks red slowly when you attach the RF module that is different from the setting.
- Under the normal usage (, that is, radio wave is being emitted), the 12Z logo turns green.

Switch (SA-SH)

(Switch Type)

- SA : 3 positions; Alternate; Short lever
- SB : 3 positions; Alternate; Long lever
- SC : 3 positions; Alternate; Long lever
- SD : 3 positions; Alternate; Short lever
- SE : 3 positions; Alternate; Short lever
- SF : 2 positions; Alternate; Long lever
- SG : 2 positions; Alternate; Short lever
- SH : 2 positions; Momentary; Long lever

*You can choose switch and set the ON/OFF-direction in the setting screen of the mixing functions.

Volume

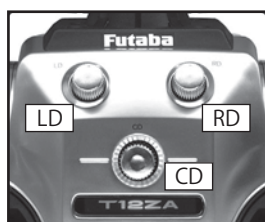

Volume LD, CD, and RD:

The volume LD and RD are analog type. You can recall the dial position data at the last operation in the Dial Monitor screen (Linkage Menu function.)

The volume CD is digital type (rotary encoder). This volume works as both a volume and a push-switch.

- *T12Z beeps when the volume knob reaches center.
- *You can check the volume position of the LD/RD functions in the Dial Monitor screen in the Linkage menu.
- *You can use each setting screen of the mixing functions to select volumes and define the direction of its movement.

Slide Lever



LS (Left), RS (right):

The side lever LS and RS are analog type. You can recall the lever position data at the last operation in the Dial Monitor screen (Linkage Menu function.)

- *T12Z beeps when the lever comes to the center.
- *You can check the lever position on the dial-monitor screen in the linkage menu.
- *You can select a slide lever and set the movement direction on the setting screen of mixing functions.

Digital trim

This transmitter is equipped with digital trims. Each time you press a trim button, the trim position moves one step. If you continue pressing it, the trim position starts to move faster. In addition, when the trim position returns to the center, the tone will change. You can always monitor trim positions by graphics on the screen.

To change the trim rate, you must activate this through the function menu, within the linkage menu. Use the cursor lever to select the trim box and then push the enter button and you will access another screen which enables you to change the trim percentages.

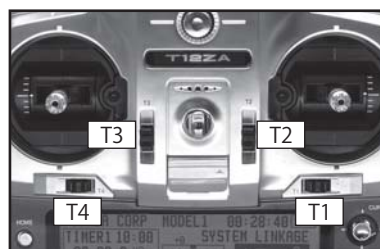

Note: The trim positions you have set will be stored in the non-volatile memory and will remain there.

Edit Key

Data input operation is performed using the cursor lever, data input dial/enter button, and return key.

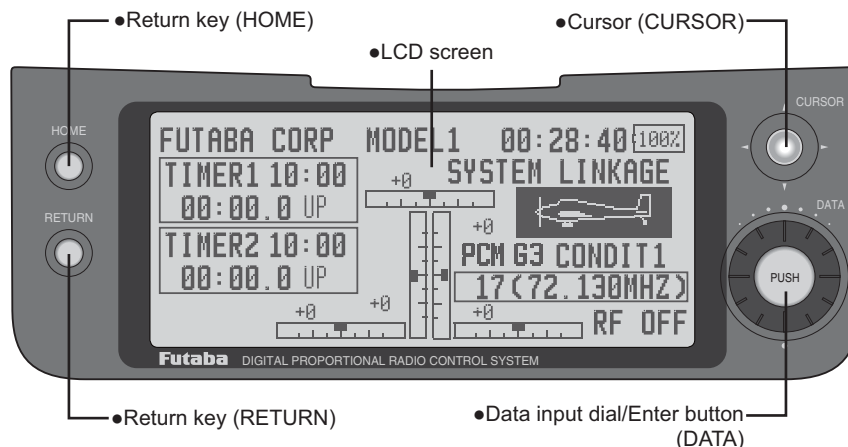

LCD screen:

The LCD screen contrast can be adjusted by system menu screen setting [DISPLAY].

Return key:

Push the return key (HOME) when you want to return directly to the home screen and push the return key (RETURN) when you want to return to the preceding screen.

Cursor lever:

The cursor lever controls movement of the cursor on menu screens and movement of the cursor

among setting items on setup screens. Up, down, left, and right movements are possible.

Push the cursor lever when you want to go directly to the next page (if there is next page.)

Data input dial/enter button

This dial/button is used during data input. Value input, mode selection, and similar operations can be performed by turning the dial to the left and right.

This dial/button can also be used as the enter button when a confirmation message is displayed on the screen, etc.

Stick Adjustment

Adjustment of the stick lever angle

You can make fine adjustments to the angle of a stick lever outwards from the initial position.



Use the attached 1.5mm hexagonal wrench to turn the screw clockwise to adjust the stick outwards, or counter-clockwise to tilt it inward.

Note: The screw will fall out if you turn the screw counter-clockwise too far.

Adjustment of the stick lever length

You can adjust the length of stick levers, as you like. It is recommended to adjust the length of the sticks in line with your hand size.

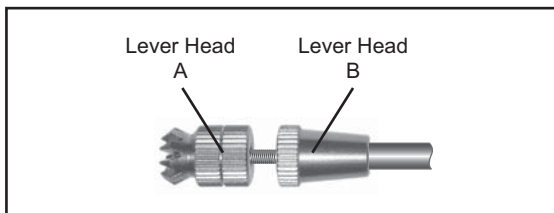

1. Hold the lever head "B" and turn the lever head "A" counter-clockwise, the lock will be released.
2. Turn the lever-head "A" clockwise as you hold the lever-head "B" after placing it as you like.

Adjustment of stick lever tension

The tension of the self-return type stick lever can be adjusted.

1. Remove the rubber grip on the back of the transmitter.

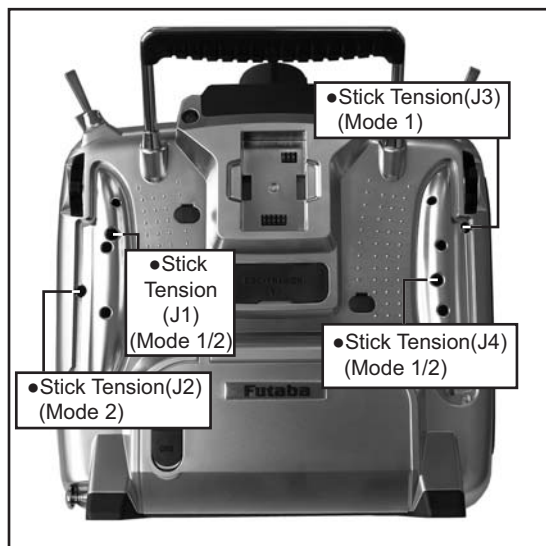

2. Use the accessory 1.5mm hexagonal wrench to adjust the spring strength as you prefer by turning the adjusting screw of the stick you want to adjust.

*Turning the screw clockwise increases the tension.

- 3) At the end of adjustment, re-install the rubber grip.

Adjustment of Throttle Stick (Ratchet System)

You can also choose either airplane ratchet system or helicopter-touch.



1. Open the dust protection cap on the back of the transmitter that is covering the hole for throttle stick adjustment.
2. Use the attached 1.5mm hexagonal wrench to turn the adjustment screw and set it as you prefer. Turning the screw clockwise increases the tension.

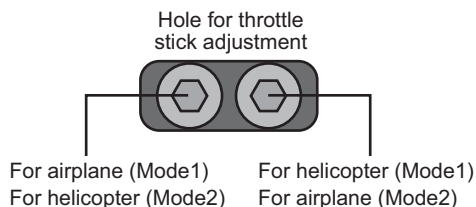

*This transmitter has two ratchet plates, one for airplane and the other one for helicopter. If you tighten both screws, you won't be able to achieve the adjustment that you need because of the overlap of those two adjustments.

*If you want to change the setting from airplane to helicopter (or from helicopter to airplane), turn counterclockwise until the throttle stick moves freely. Then turn the screw for the helicopter (or airplane) until you get the tension you like.

CF Card CFDP32M (Optional)

The T12Z transmitter model data can be stored by using an optional CF (Compact Flash) card. When T12Z transmitter software update software is released, the software is updated using a CF card. CF card memory size is 32MB.



⚠ Warning

- ❗ Be sure to turn off the power to the transmitter before inserting or removing the CF card.
- ⊘ As the CF card is a precision device, do not use excessive force when inserting.
- ❗ Be sure to use only Futaba's original CF card, CFDP32M, for the T12Z transmitter.

* Futaba does not recommend any CF cards other than Futaba's original CF cards.

Inserting/removing the CF card

1. Turn off the transmitter power and then open the cover (rubber) at the left side of the transmitter.

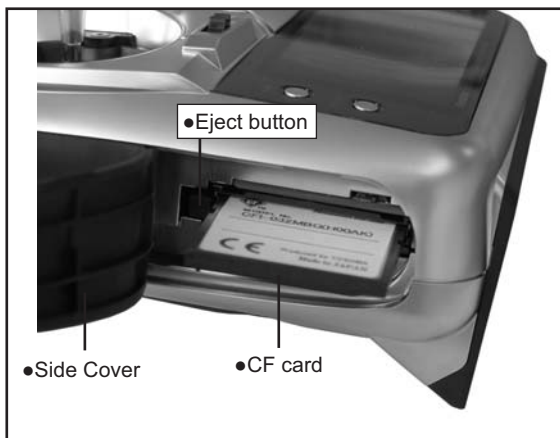

2.

[Inserting the card]

*Turn the CF card so that the front of the card faces the back of the transmitter and slide the card into the card slot.

*Push in the card until it touches bottom. At the same time, the eject button pops out.

[Removing the card]

*When the eject button is pushed; the CF card is pushed out and can be removed.

3. Close the cover (rubber).

Read data from a PC

Saving model data and update files (released from Futaba) into the CF card, you can use those files on your T12Z transmitter. Equipment for reading and writing CF cards are available at most electronics stores.

[Important]: Before saving data from the PC, insert the CF card into the transmitter and turn on the power. To save a model data file from the PC, copy the file to the "MODEL" folder, which is automatically written.

*Use only CF card reader/writer that complies with CFA (CompactFlash™ Association) standard.

Stored data

The life of the CF card is limited due to the use of Flash memory. When you have a problem of saving or reading data such as picture data after a long period of use, please get a new CF card.

*We do not have the responsibility of compensating any failure or damage to the data stored in the memory card no matter what the reason is. Be sure to keep the backup of your important data in your CF card.

***No necessity for backup;** T12Z transmitters and CF cards are using nonvolatile memory devices so that the data stored in those will not be lost, even when the main battery is removed.

Connector/Plug

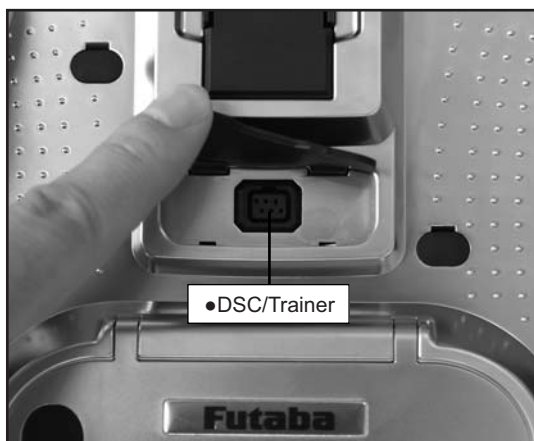

Connector for trainer function (TRAINER)

When you use trainer function, connect the optional trainer cable between the transmitters for teacher and student.

*You can set the trainer function on the Trainer Function screen in the system menu.

Connector for DSC function (DSC)

You can operate the transmitter without transmitting radio waves by connecting the transmitter and the receiver to the DSC cable.

*Please refer to the section "Connection between Receiver/ Servo"

Connector for battery charger (CHG)

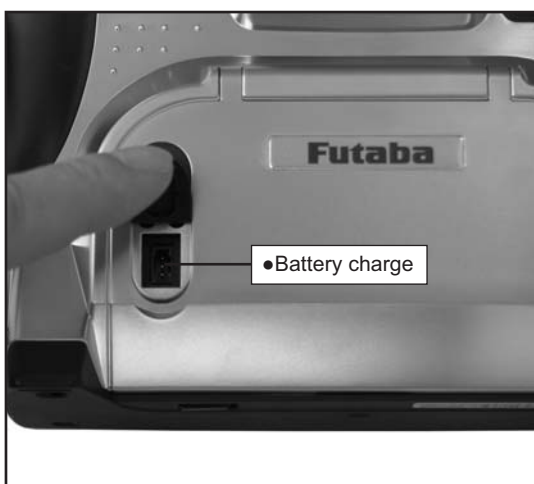

This is the connector for charging the Lithium Ion battery LT2F2200 that is installed in the transmitter. Do not use any other chargers except

CR-2500 that is for 12V application to charge the LT2F2200 battery through this connector.

⚠ Danger

- ⊘ Do not connect any other chargers except CR-2500 to this charging connector.

*If you take out the Lithium Ion battery LT2F2200 from the transmitter, you can use the attached charger LBC-1D5 for charging the battery.

Installing and Removing of the battery LT2F2200 for the transmitter

Attachment of the battery

1. Hook your finger in the slit formed by the transmitter's main body and the battery cover on the bottom of the transmitter, and then pull up the cover to release the lock. You can now open the cover.
2. Move the slide lever to the right and then install the battery in the holder.

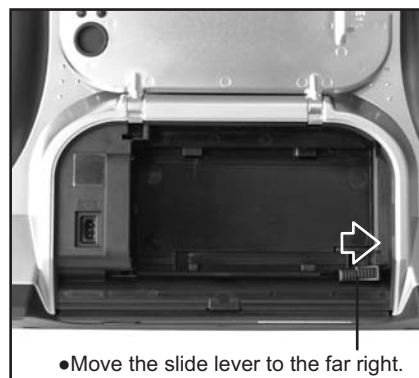

3. Push the battery to the left with your finger.



4. Close and lock the battery cover completely.

Removing of the battery

Note: If you remove the battery while the power is on, the data you have set will not be saved.

1. Hook one of your fingers in the slit formed by the transmitter's main body and the battery cover on the back and bottom of the transmitter, and then pull up the cover to release the lock. You can now open the cover.
2. Slide the slide lever to the right while pressing it, the battery will be released.

Warning

 Be careful to not drop the battery.

 Never take out the battery from the T12Z transmitter while the LED monitor is blinking yellow after turning off the power the T12Z transmitter.

* Internal devices such as memories may be damaged.

* If there is any problem, the message "Backup Error" will be shown the next time when you turn on the power of the transmitter. Do not use the transmitter as it is, send it to the Futaba Service Center.

*There is a connector above and under the module respectively. So, you might find difficulty in pulling out the module if the module is tilted.

Attachment of the RF module

Insert the module with care so that the connector pins of the transmitter won't be bent.

RF module MZ-FM

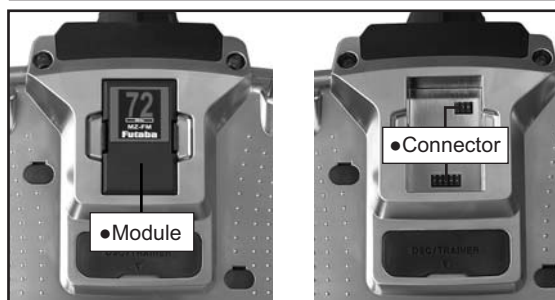

Caution

 Be sure to turn off the power of the transmitter before you attach or detach the module.

Detachment of the RF module

Pull the module straight while you are pushing inward the projections on both sides of the module.

Receiver nomenclature

Before using the receiver, be sure to read the precautions listed in the following pages.

Receiver R5014DPS

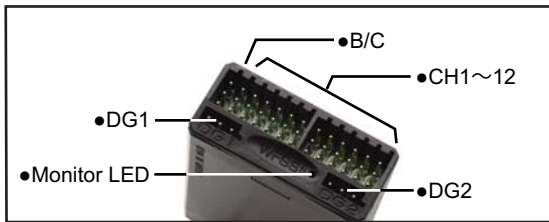
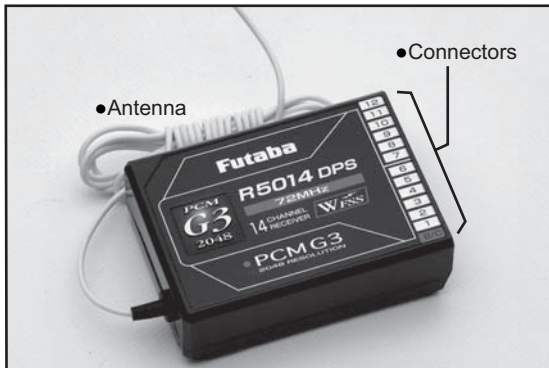

Connector

"1 through 12": outputs for the channels 1 through 12

"DG1", "DG2": outputs of DG1 and DG2 channels

"B/C": connector for the power and DSC.

LED Monitor

This monitor is used when changing the frequency of the receiver.

Safety precautions when you install receiver and servos

⚠ Warning

Connecting connectors

- ❗ Be sure to insert the connector until it stops at the deepest point.

How to protect the receiver from vibration and water

- ❗ Wrap the receiver with something soft such as foam rubber to avoid vibration. If there is a chance of getting wet, put the receiver in a waterproof bag or balloon to avoid water.

Receiver's antenna

- ⊘ Never cut the receiver's antenna. Do not bind the receiver's antenna with the cables for servos.
- ❗ Locate the receiver's antenna as far as possible from metals or carbon fiber components such as frames, cables, etc.

*Cutting or binding the receiver's antenna will reduce the radio reception sensitivity and range, and may cause a crash.

Servos throw

- ❗ Adjust your system so that pushrods will not bind or sag when operating the servos to the full extent.

*If excessive force is continuously applied to a servo, your aircraft may crash because the servo would be damaged and the battery would be consumed rapidly.

Mounting servos

- ❗ Use a vibration-proof rubber (such as rubber grommet) under a servo when mounting the servo on a servo mount. And be sure that the servo cases do not touch directly to the metal parts such as servo mount.

*If a servo case is contacting directly to the airframe, the vibration of the airframe directly travels to and may damage the servo.

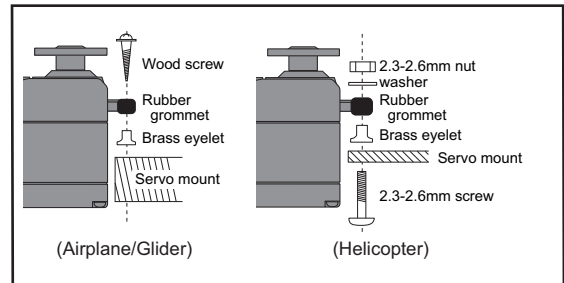

Internal antenna mounting (Airplanes)

- Use rubber band to stretch antenna and then fix it.
- Use a rubber bushing to the position where antenna is coming out from the airframe so that the antenna won't be cut due to the friction.
- Use rubber band to stretch antenna and then fix it. Make a knot inside of the airframe so that the antenna will not fall out.

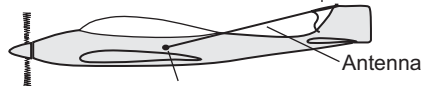

Mounting the power switch

When mounting a power switch to an airframe, make a rectangular hole that is a little larger than the total stroke of the switch so that you can turn the switch ON/OFF without binding.

Avoid mounting the switch where it can be covered by engine oil and dust. In general, it is recommended to mount the power switch on the side of the fuselage that is opposite the muffler.

BASIC OPERATION

Battery Charging

Before charging batteries, read the "Cautions for handling battery and battery charger" in the section "Lithium-Ion Battery Safety and Handling Instructions".

How to charge the Lithium Ion battery LT2F2200 for the transmitter

⚠ Danger

⊘ The Lithium-Ion battery LT2F2200 is only for your T12Z. Do not use this battery for other equipment.

! Be sure to use the battery charger LBC-1D5 to charge the battery.

! To charge the battery while installed in the transmitter, use the optional battery charger CR-2500 for 12V.

[Method of charging battery]

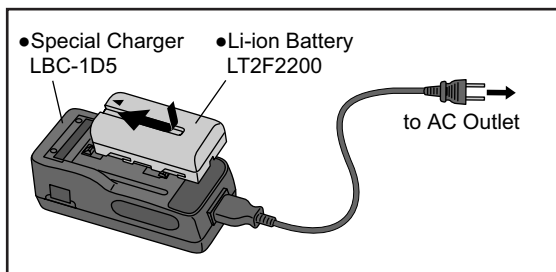

1. Connect the power cable to the charger.
2. Connect the power cable of the charger to the wall socket (AC outlet).
 - * The power lamp turns on.
3. Mount the battery and then slide the battery in the direction shown in the figure until you hear a locking sound.
 - *The charge-lamp turns on and charging starts.
4. When the charge-lamp turns off, charging has been completed.
 - *Be sure to remove the power cable from the wall socket after using a battery charger.
 - *It takes about two and a half hours for charging the battery pack that has been used fully. However, the charging time may vary depending on the surrounding air temperature and the condition of the battery pack.
 - *The charge LED blinks (error) if the battery is improperly mounted or the battery itself is a defective product. In this case, remount the battery or use another battery.
 - *If you mount a charged battery, the charge lamp will turn on for several seconds, but it will turn off later.

How to charge the Ni-Cd battery NR4F1500 for the receiver

Use the battery charger FBC-32A that is included in the set.

[Method of charging battery]

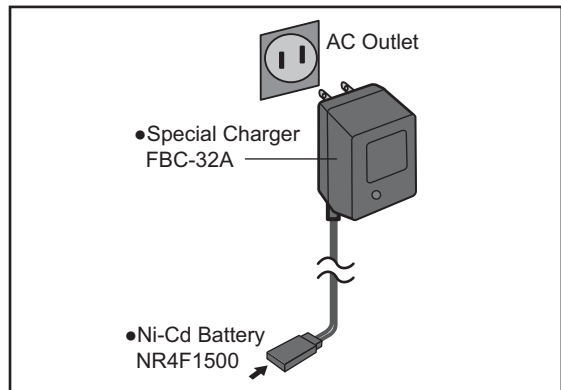

1. Connect the power cable of the charger to the wall socket (AC outlet).
2. Connect the connector to the NiCd battery.
 - *Confirm that the charging indicator, LED lamp, is on.
3. Remove the battery after 15 hours.
 - *Battery charging will not automatically stop. Remove the battery from the charger and remove the charger from the wall socket.
 - *It is recommended to reactivate the battery by cycling several times if the battery has not been used for a long period.
 - *In case of NiCd battery, you may find the poor performance of the battery if you have used the battery only for a short period or if you repeat charging while the battery is not fully discharged. It is recommended to discharge the battery to the recommended level after your usage. It is also recommended to charge the battery just before your usage.

How to turn ON/OFF the power of the transmitter

For safety reasons, the radio will be emitting only after confirming when turning on the power. Please follow the instructions for turning on/off the transmitter.

When turning on the power of the transmitter

1. Turn on the power switch of the transmitter.

*After initialization of the transmitter is over, the frequency confirmation screen pops up, and LED monitor turns on pink.

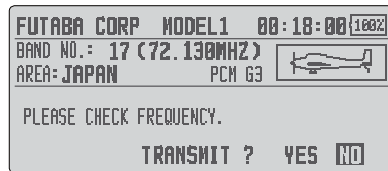

2. Check the frequency shown on the screen. If it is OK, then select [YES] and push the enter button.

*LED monitor turns to green and the transmitter begins to emit radio waves.

*To not transmit, select [NO] and push enter button.

Then, you will see the home screen and you will be able to set conditions.

How to stop the transmitter

Turn off the power switch of the transmitter. The internal circuit of the transmitter starts the shut down process including saving the set-up data. The LED will blink yellow while the transmitter is in the shutdown process.

Warning

-  Once you turn off the power, never operate the power switch until the power shutdown process is fully completed. If you turn on the power switch again while the transmitter is still in the process of power shutdown, the transmitter power does not start.

How to change the frequency/How to set ID

The T12Z system has employed the frequency synthesizer scheme. The T12Z transmitter will set the frequency of the R5014DPS (PCMG3 receiver) by the wireless data transmission. When you are using a new PCMG3 receiver and changing the frequency, set ID or frequency using the following instructions.

In case of using PCMG3 receivers

*Make sure that PCM-G3 is set as a modulation scheme. Then change the frequency by the following instruction.

How to change the frequency

1. Turn on the transmitter power. A confirmation message ("TRANSMIT?") is displayed. Since you do not want to transmit, select [NO] and then push the enter button.
2. Select the area that displays the frequency on the home screen or in the linkage menu and push the enter button.

*The frequency setup screen appears.

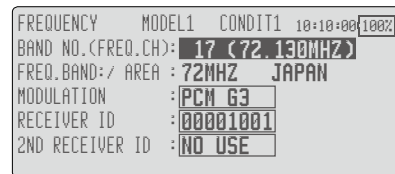

3. Select [RECEIVER ID] and push the enter button.

*The receiver ID code input screen appears.

4. Input the 8-digit ID code stuck to the receiver case. If the inputted ID code is correct, select [ENTER] and then push the enter button.

*Select the figure with the cursor key and push the enter key for each digit.

*Use [BACK SPACE] to move back digit by digit for correction if you made a mistake. When you want to stop ID code change, push the return key to return to the original screen.

*Once the receiver ID code is set, it does not have to be reset as long as the receiver is not changed.

*When you use two receivers with a large aircraft, input the ID of each receiver.

5. When switching the frequency, select [BAND NO.] and push the enter button.

*The frequencies which can be selected appear on the screen.

6. Select the frequency you want to use and push the enter button.

*A confirmation message appears.

*When changing the frequency band, change the module before turning on the power.

7. If the frequency is correct, push the enter button.

*A screen which shows that frequency data is being sent

is displayed and the frequency data is sent to the receiver together with a message sound. (The frequency data can be resent by selecting [RETRY] and pushing the enter button.)

- Turn on the receiver power while the new frequency data above is displayed.

*When receiver frequency setting is complete, the receiver monitor LED blinks once and the CH1 servo shuttles 3 times across the neutral position.

*The new receiver frequency data uses very low power whose frequency is different from that of frequency channel used. When setting the receiver frequency, bring the transmitter and receiver as close together as possible.

*If the new data is not read correctly due to the ambient conditions, extend the transmitter antenna and bring the transmitter close to the receiver antenna and repeat steps 5 through 7.

*The frequency can also be changed by connecting the transmitter and receiver directly with the DSC cord and performing steps 5 through 8.

*When the receiver ID code is incorrect, the monitor LED will blink. Return to the receiver ID setup screen and reset the receiver ID.

- When frequency setting is complete, move the cursor to the [END] position and push the enter button.

- A confirmation message ("TRANSMIT?") is displayed. To send on the new frequency, select [YES] and push the enter button.

*To not transmit, select [NO] and push the enter button.

In case of using PCM1024, PPM receivers

*Make sure that PCM1024 or PPM is set as a modulation scheme. Then change the frequency by the following instruction.

How to change the frequency

- Turn on the transmitter power. A confirmation message ("TRANSMIT?") is displayed. Since you do not want to transmit, select [NO] and then push the enter button.
- Select [FREQUENCY] of the area that displays the frequency on the home screen or in the linkage menu and push the enter button.

*The frequency setup screen appears.

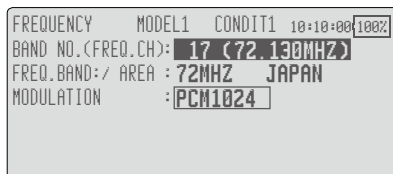

- When switching the frequency, select [BAND NO.] and push the enter button.

*The frequencies which can be selected appear on the screen.

- Select the frequency you want to use and push the enter button.

*A confirmation message appears.

- If the frequency is correct, push the enter button.

- A confirmation message ("TRANSMIT?") is displayed. To send on the new frequency, select [YES] and push the enter button.

*To not send, select [NO] and push the enter button.

Registration of the user's name

T12Z transmitter can register user's name.

How to register user's name

- Turn on the power of the transmitter.
- Select [USER NAME] of the area that displays the user's name on the home screen or in the system menu and push the enter button.

*The user name set up screen appears.

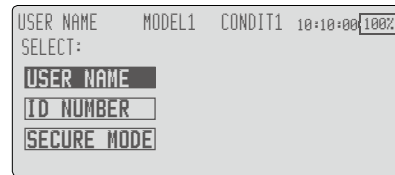

- Select [USER NAME] and push the enter button. Then the set up screen will pop up. You can use up to 12 characters as a user's name.

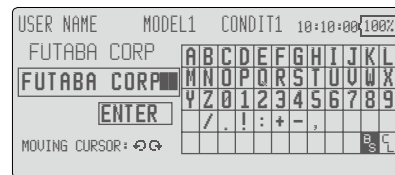

*For a description of the user's name registering: p.33.

- Push "Return" key to return to the previous screen after entering the user's name.

(If you want to protect the user's name)

If you don't want anybody else to change your user's name, set your ID.

*Please be aware that you will not able to change user's name if you forget your password.

*For a description of the user's name protection method: p.33.

Home screen

Use the cursor lever to select the following display area to call each setting screen, and push the enter button. The setting screen appears.

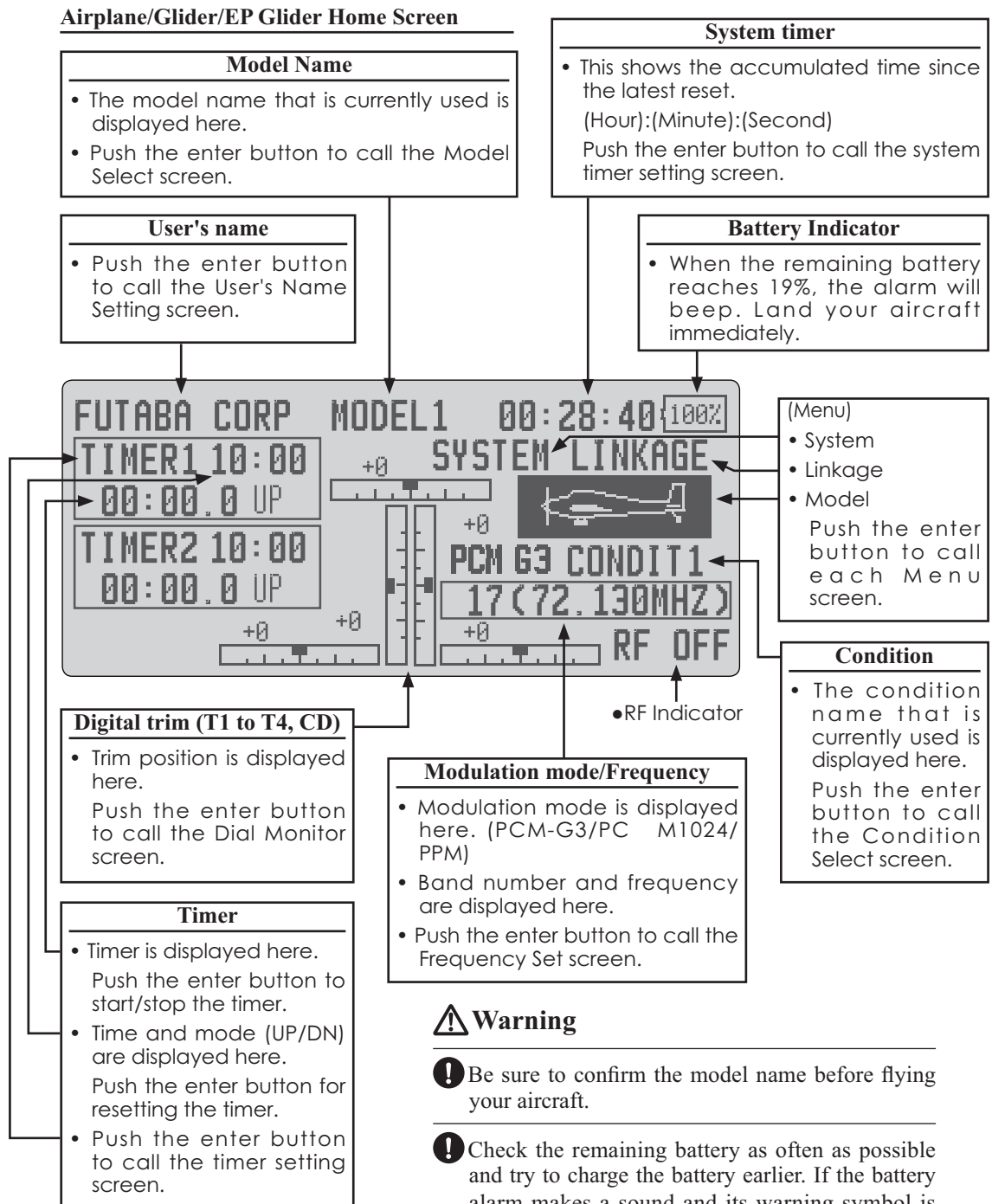

⚠ Warning

- ❗ Be sure to confirm the model name before flying your aircraft.
- ❗ Check the remaining battery as often as possible and try to charge the battery earlier. If the battery alarm makes a sound and its warning symbol is displayed, land your aircraft immediately.

*You can adjust the LCD contrast by the display setting in the system menu.

Helicopter Home Screen

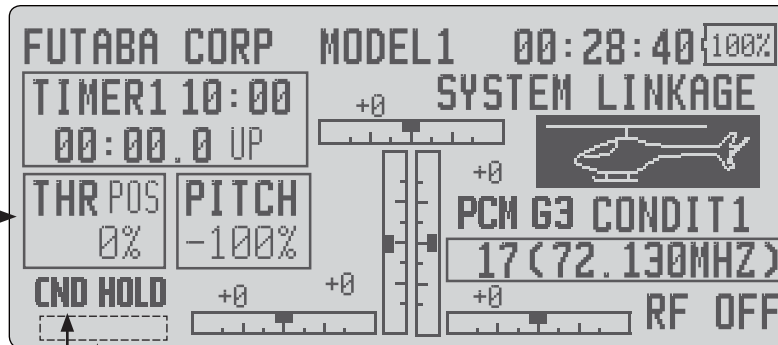

*Condition hold operation is displayed. ("IS ACTIVE")

To activate/deactivate Condition Hold:

1. Move the cursor to [CND HOLD].
2. Set the throttle stick lower than the 1/3 point and push the enter button to activate/deactivate the condition hold function.

*See p.68 for condition hold function details.

Throttle/Pitch Position Display

- Throttle and pitch position is displayed here.
Push the enter button to call the throttle curve or Pitch curve setting screen directly.

SYSTEM MENU

The System Menu sets up functions of the transmitter, this does not set up any model data.

- Select [SYSTEM] at the home screen and call the system menu shown below by pushing the enter button.
- Use the cursor lever to select the function you want to set and call the setup screen by pushing the enter button..

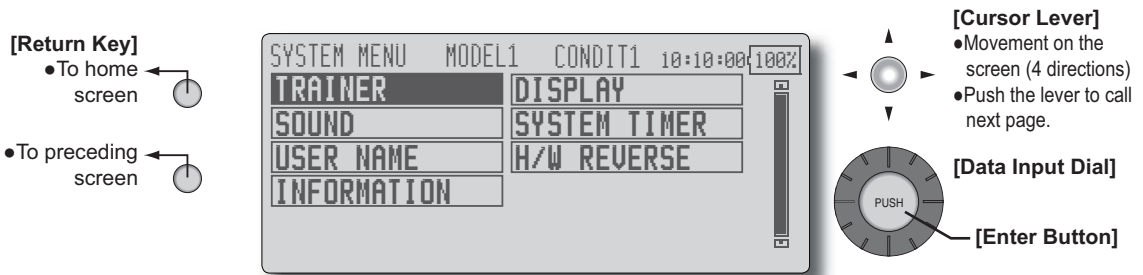

System Menu functions table

[TRAINER]: Starts and sets the trainer system.

[DISPLAY]: Display adjustment and auto power off setting.

[SOUND]: Adjusts the speaker volume.

[SYSTEM TIMER]: Resets the accumulated timer.

[USER NAME]: User name registration and ID Pin number.

[H/W REVERSE]: Reverses the direction of operation of the sticks, switches, trim levers, knobs, etc.

[INFORMATION]: Displays the program version, CF card information, and product ID.

The Trainer function makes it possible for the instructor to choose which functions and channels are to be used for instruction, making it possible to match the training ability to the student's skill level. Two transmitters must be connected by an optional Trainer Cord, and the Instructors' transmitter should be programmed for trainer operation, as described below.

When the Instructor activates the trainer switch, the student has control of the aircraft (if MIX or FUNC mode is turned on, the Instructor can make corrections while the student has control). When the switch is released the Instructor regains control. This is very useful if the student gets the aircraft into an undesirable situation.

NOTE: This trainer system can be used in the following manner;

1. With the T12Z transmitter and a conventional transmitter, if the channel order is different. It is necessary to match the channel order in the Function setting screen when connecting it with other than a T12Z.
2. When the T12Z is used as the Teacher, set the modulation mode of the student's transmitter to PPM. If being used as the student, set the T12Z to the modulation mode specified by the Instructors' transmitter. When the Instructors' transmitter is a T14MZ, 12Z, T9Z, T9C or T7C transmitter, it should be switched to PPM mode.
3. Be sure that all channels work correctly in both transmitters before flying.

Corresponding types of transmitters:

T4VF, T6VA, T6DA, T6YG, T6YFK, T6X, T6EX, T7U, T7C, T8U, T9C, T9Z, T12Z, T14MZ

- Select [TRAINER] at the system menu and call the setup screen shown below by pushing the enter button.

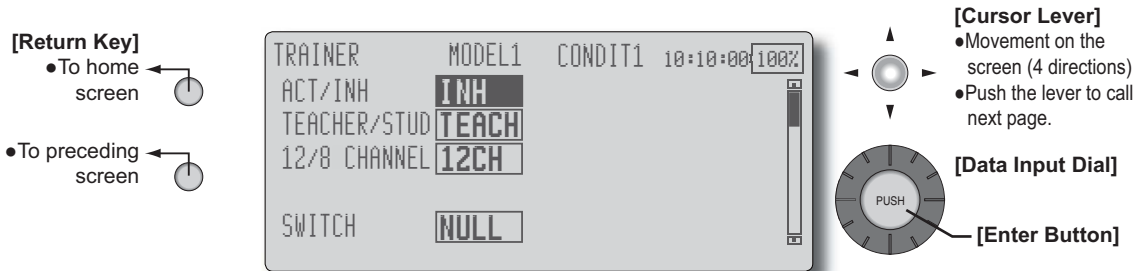

(The display screen is an example. The screen depends on the model type.)

When using at the teacher side

1. Select the mode.

*When changing the mode, use the cursor lever to move to the item you want to change and change the mode by turning the data input dial to the left or right. The display blinks. Press the enter button to change the mode.

"TEACHER/STUD": Select [TEACH].

"ACT/INH": Enable operation by changing to [OFF] or [ON].

"12/8 CHANNEL": When the student uses the T12Z (including the T14MZ or FX-40), select [12CH]. Otherwise select [8CH].

2. Select the trainer switch.

*When setting or changing the switch, use the cursor lever to move to the "SWITCH" item, call the switch setup screen by pushing the enter button and set the desired switch and ON/OFF direction.

(See "Switch selection method" at the end of this manual for selection method details.)

*The switch mode can also be selected when setting the

ON position on the switch setup screen. When [NORM] is selected, normal ON/OFF operation is performed. When [ALT] is selected, the trainer function is alternately turned on and off each time the switch is operated. This allows alternate ON/OFF switching even when a momentary switch (SH) is used.

3. Select the operating mode for each channel.

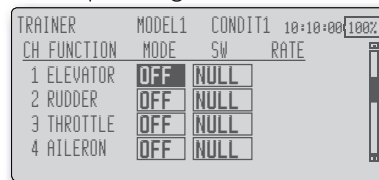

*Use the cursor lever to move the cursor to the "MODE" item of the channel you want to change and change the mode by turning the data input dial to the left or right. The display blinks. Press the enter button to change the mode.

"NORM": The model is controlled by signals from the student transmitter.

"MIX" mode: The model is controlled by signals transmitted from the teacher and

student transmitters.

"FUNC" mode (function mode):

The model is controlled by signals from the student transmitter with the teacher AFR setting.

"OFF": Only the teacher side operates.

*The setting above allows setting of the servo throw relative to the amount of student side operation when [MIX] or [FUNC] was selected.

When changing the rate, use the cursor lever to move the cursor to the [RATE] item of the channel you want to change and use the data input dial to adjust the rate.

Setting range: -100~+100

Initial value: +100

3. Set the switch of each channel.

*When setting the switch at each channel, use the cursor lever to move to the "SW" item of the channel you want to change, call the switch setup screen by pushing the enter button, and select the switch.

"NULL" : Always ON.

"SA"~"SH": The switch which enables student side operation can be selected. (See "Switch selection method" at the end of this manual for selection method details.)

[Caution]: In the student mode, the trainer function display is not turned on as long as the teacher transmitter does not receive signals from the student transmitter (when the student transmitter is not connected)

mode", the trainer function won't be turned on unless the Instructors' transmitter receives signals from the student's transmitter. Be sure to confirm this after connecting your trainer cable.

When using at the student side

1. Select the mode.

*When changing the mode, use the cursor lever to move to the item you want to change and change the mode by turning the data input dial to the left or right. The display blinks. Press the enter button to change the mode.

"TEACHER/STUD": Select [STUD] (student).

"ACT/INH": Enable operation by changing to [ON].

"12/8 CHANNEL": When the student uses a T12Z (including the T14MZ and FX40), select [12CH]. Otherwise select [8CH].

"MODULATION": Set to the mode ([PPM] or [PCM]) specified by the student side transmitter.

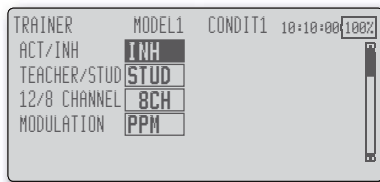

Note: In "student mode", only the teacher side can turn on and off the power to the student's transmitter. Keep the power switch always at off position. Note: In "teacher

The following LCD screen adjustments and auto power off setting are possible:

- Contrast adjustment
- Auto power off time setting

- Select [DISPLAY] at the system menu and call the setup screen shown below by pushing the enter button.

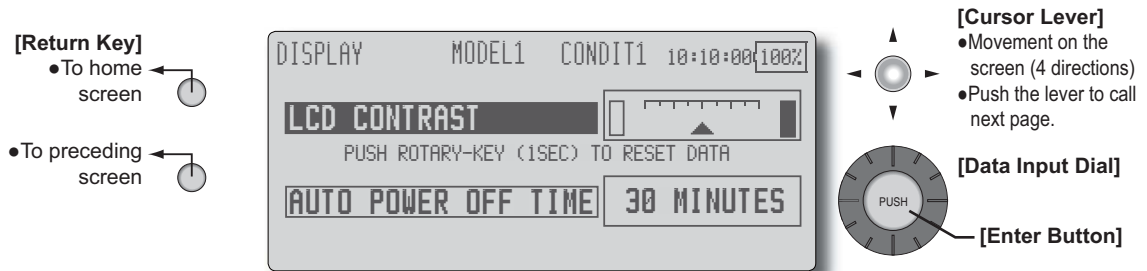

LCD contrast adjustment

1. Adjust the screen contrast.

*Use the cursor lever to select "LCD CONTRAST" and adjust the contrast by turning the data input dial to the left and right.

Adjust to the contrast while watching the screen display.

Move the arrow on the screen and display the current setting position.

(Left side): Lighter

(Right side): Darker

*When you want to reset the contrast to the initial state, select "LCD CONTRAST" and push the enter button for 1 second. LCD CONTRAST is reset to the center position.

Auto power off time setting

1. Set the time the auto power off function operates.

*When the amount of time a stick, switch, etc. (excluding screen operation) is not operated exceeds the set time, the power is automatically turned off. This time can be set up to 1 hour in 10 minute steps. "Auto power off" can also be disabled ("NEVER").

*When the transmitter is expected to be idle for a long time during flight with a glider, etc., set the auto off timer to "NEVER" or a long time.

SOUND

Adjusts the speaker volume.

This function adjusts the volume of the edit operation, trim and knob operation, and power ON/OFF confirmation sound and the alarm sound, etc. from the transmitter speaker.

[Note]: Some sounds, such as the power ON/OFF confirmation sound, alarm sound, and some other important sounds are not affected by setting.

- Select [SOUND] at the system menu and call the setup screen shown below by pushing the enter button.

[Return Key]

- To home screen
- To preceding screen

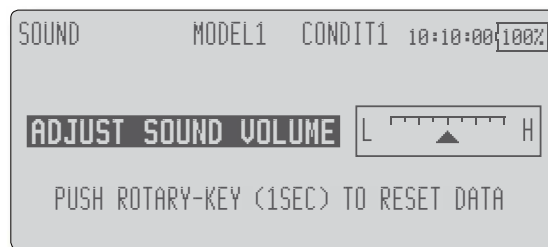

[Cursor Lever]

- Movement on the screen (4 directions)
- Push the lever to call next page.

[Data Input Dial]

[Enter Button]

Volume adjustment

1. Adjust the speaker volume.

*Adjust the speaker volume by turning the data input dial to the left and right.

Adjust the speaker volume by listening to the sound at adjustment. The arrow on the screen moves and displays the current setting position.

(Left side) : Volume decreases

(Right side) : Volume increases

*When you want to return to the initial state, push the enter button for 1 second. The arrow returns to the center position.

SYSTEM TIMER

Resets the accumulated timer.

This function resets the system timer displayed on the home screen and other setup screens.

- System timer displays the total accumulated time on the transmitter from the last time the timer was reset.
- This setup screen can also be called directly from the home screen.

- Select [SYSTEM TIMER] at the system menu and call the setup screen shown below by pressing the enter button.

The setup menu can also be called by selecting system timer at the home screen and pressing the enter button.

[Return Key]
• To home screen

• To preceding screen

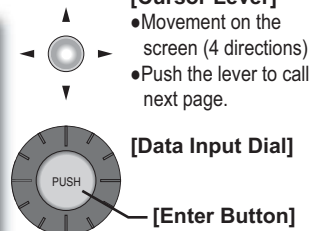

[Cursor Lever]

- Movement on the screen (4 directions)
- Push the lever to call next page.

[Data Input Dial]

[Enter Button]

Timer reset

1. Reset the timer to "00:00:00" by pushing the enter button for 1 second. After reset, the timer restarts from "00:00:00".

- Use the cursor lever to select [ID NUMBER] and then push the enter button. The user ID number setup screen appears.

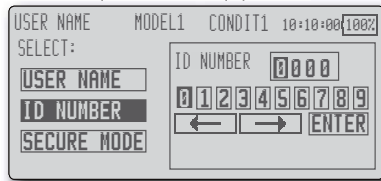

- Use the cursor lever to select the first digit and then push the enter button. Sequentially set the 4 digits.

*The digit shifts automatically. However, to shift to a specific digit, use the cursor lever to select the arrow symbol and move the arrow symbol by pushing the enter button.

- When input is complete, select [ENTER] and push the enter button. A confirmation message appears.
- End by pushing the enter button again.

*Once the transmitter power is turned off, the set security mode is enabled.

*When a PIN number was set for the user name, the PIN number must be input the next time the user name setup screen is opened.

When a system PIN number was set, [INPUT ID] is displayed on the home screen. When this button is selected and the enter button is pushed when you want to change the setting, the PIN number input screen appears.

*When you want to clear the PIN number, set to "0000" (initial state).

H/W REVERSE

Stick, switch, trim lever, and knob operation direction reversal (Hardware reverse)

This function reverses the operation signal of the sticks, switches, trimmer levers, and knobs.

Note: This setting reverses the actual operation signal, but does not change the display of the indicators on the display. Use the Normal mode as long as there is no special reason to use the Reverse mode.

- Select [H/W REVERSE] at the system menu and call the setup screen shown below by pushing the enter button.

[Return Key]

- To home screen
- To preceding screen

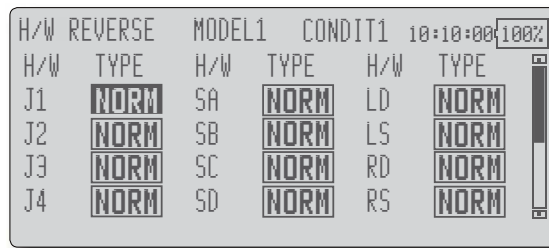

[Cursor Lever]

- Movement on the screen (4 directions)
- Push the lever to call next page.

[Data Input Dial]

[Enter Button]

Operation direction reversal method

1. Use the cursor lever to move the cursor to the "TYPE" item corresponding to the H/W (hardware) you want to reverse.
2. Change the mode by turning the data input dial to the left or right. The display blinks. When the enter button is pushed, the operation direction is reversed.

"NORM": Normal operation direction

"REV" : Operation direction is reversed.

[Stick, switch, etc.]

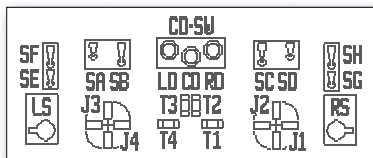

INFORMATION



Displays the program version, CF card information, and product ID.

The T12Z system program version information, CF card information (memory size, vacant capacity, number of model data), and product ID are displayed on the Information screen.

*When the CF card is not inserted, the CF card information is not displayed.

- Select [INFORMATION] at the system menu and call the setup screen shown below by pushing the enter button.

[Return Key]

- To home screen 
- To preceding screen 

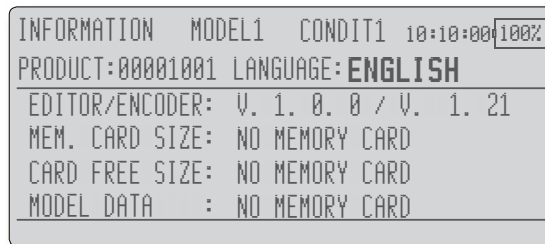

Information

"PRODUCT": Product ID number

"EDITOR/ENCODER": T12Z system program version information

"MEM. CARD SIZE": Memory size (CF card)

"CARD FREE SIZE": Vacant capacity (CF card)

"MODEL DATA": Number of model data (CF card)

MODEL BASIC SETTING PROCEDURE

Airplane/glider basic setting procedure

1. Model addition and call

Initial setting assigns 1 model to the T12Z transmitter. The Model Select function of the Linkage Menu is used to add models and to select models which are already set.

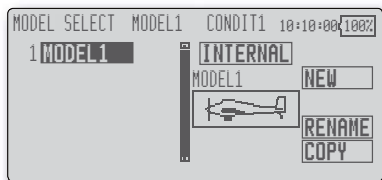

The data for up to 25 models can be saved to the transmitter. Data can also be saved to the optional CF card.

The currently selected model name is displayed at the top of the screen. Before flying and before changing any settings, always confirm the model name.

When a new model is added, the Model type select screen and Frequency/Modulation mode/Receiver ID setup screen automatically appear. Please be aware that the transmitter will stop transmitting when you change the model.

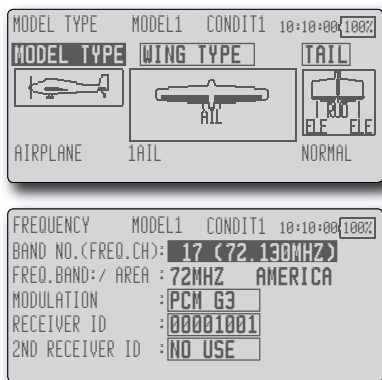

2. Model type selection

Select the model type matched to the aircraft with the Model Type select function of the Linkage Menu. For an airplane, select the model type from among the 3 types: airplane, glider, and motor glider. After the wing type is selected the Tail type select screen is displayed. Select the tail type matched to the aircraft.

There are 13 wing types and 3 tail types for airplane, glider, and motor glider.

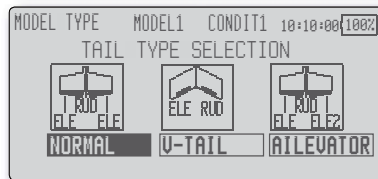
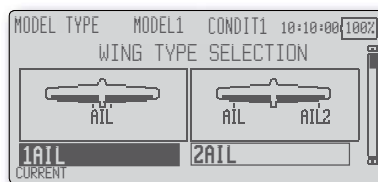

3. Fuselage linkage

Connect the ailerons, elevators, throttle, rudder, etc. in accordance with the model's instruction manual. For a description of the connection method, see the Receiver and Servos Connection.

Note: The channel assignment of the T12Z is different from that of our existing systems. Note that even for the same "airplane model", when the wing type and tail type are different, the channel assignment may be different. (The channel assigned to each function can be checked at the Function menu of the Linkage Menu.)

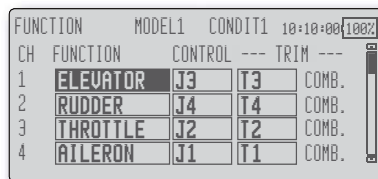

- If the direction of the servo is incorrect, adjust the direction with the Reverse function of the Linkage Menu.

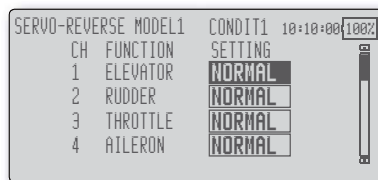

- Adjust the neutral position and control surface angle with the linkage, and fine tune them with the Sub Trim and End Point functions (angle adjustment). To protect the linkage, a limit position can also be set with the End Point function. The End Point function can adjust the amount of up/down and left/right movement, limit, and servo speed of each channel.

4. Throttle cut setting

Throttle cut can be performed with one touch by a switch without changing the throttle trim position.

Set throttle cut with the Throttle Cut function of the Linkage Menu. After activating the throttle cut function and selecting the switch, adjust the throttle position so that the carburetor becomes fully closed. For safety, the throttle cut function operates the throttle stick in the 1/3 or less (slow side) position.

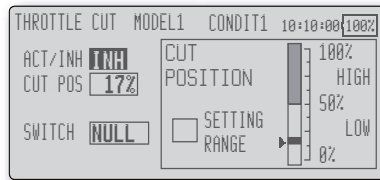

5. Idle down setting

The idling speed can be lowered with one touch by a switch without changing the throttle trim position. Perform this setting with the Idle Down function of the Linkage Menu. After activating the Idle Down function and selecting the switch, adjust the idle down speed. For safety, the idle down function acts only when the throttle stick is slow side.

*While the Throttle Cut function is in operation, the Idle Down function does not work.

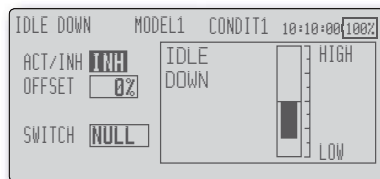

6. AFR (D/R)

AFR function is used to adjust the throw and operation curve of the stick, lever, and switch functions (CH1 to CH12, and V1 to V4) for each flight condition. This is normally used after End Point (ATV) has defined the maximum throw directions.

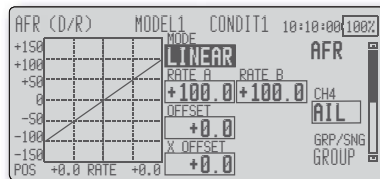

7. Airbrake

This function is used when an air brake is necessary when taking off or diving, etc.

The preset elevators and flaps (camber flap, brake flap) offset amount can be activated by a switch.

The offset amount of the aileron, elevator, and flap

servos can be adjusted as needed. Also the speed of the aileron, elevator, and flap servos can be adjusted. (IN side/OUT side) A delay can be set for each condition, and a Cut switch which will turn OFF the delay can be chosen. Trim amounts can be fine-tuned by setting a VR. You can also set the Auto Mode, which will link Airbrake to a stick, switch, or dial. A separate stick switch or dial can also be set as the ON/OFF switch.

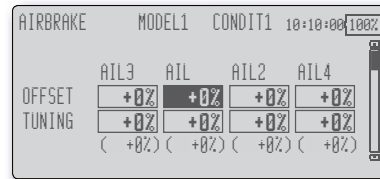

8. Addition of flight conditions

The transmitter can install up to eight flight conditions per model. You can assign all switches including sticks, switches, trim levers and trim switches as flight-condition selection switches. You can also add delayed mixing to these functions in order to avoid sudden changes. Moreover, you can set priority order for flight conditions when you set more than one condition. In addition, you can copy conditions and/or change names of conditions. This command may also be used to define what switches and/or controls are used to activate each flight condition.

The Condition Select function automatically allocates the Condition 1 for each model type. Condition 1 is the default condition, also referred to as Normal, and is the only one active when a new model type is defined. This condition is always on, and remains on until other conditions are activated by switches.

The Condition Delay can be programmed for each channel. The Condition Delay is used to change the servo throw smoothly when switching conditions.

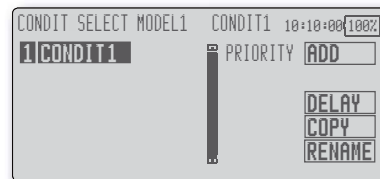

*When a new condition is added, "Condition1" data is automatically copied.

*Select the condition switch and set the new condition data in the switch ON state. However, if the group mode (GROUP) was selected in advance, the same data will be input at all the conditions. Select the single mode (SINGLE) and adjust the condition you want to change.

9. When tailless wing model selected

Tailless wing elevator operation uses elevator to camber mixing. This function cannot be performed at initial setting.

Helicopter basic setting procedure

This section outlines examples of use of the helicopter functions of the T12Z. Adjust the actual values, etc. to match the fuselage used.

1. Model addition and call

Default setting assigns 1 model to the T12Z. To add new models or to call a model already set, use the Model Select function of the Linkage Menu.

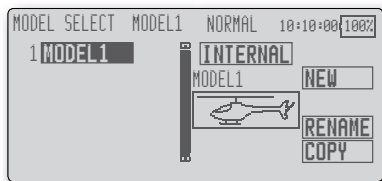

This is convenient when calling a model after registering the model names in advance. (The data of up to 25 models can be saved at the transmitter. Data can also be saved to the optional CF card.)

The currently called model is displayed at the top of the screen. Before flying and before changing any settings, always confirm the model name.

When a new model is added, the Model Type Select screen and Frequency/Modulation mode/Receiver ID setup screen automatically appear. Change, or check that they match the type, frequency, and receiver type of the model used.

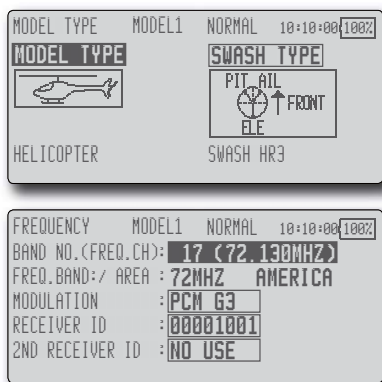

2. Model type and swash type selection

If a different model type is already selected, select helicopter with the Model Type function of the Linkage Menu, and then select the swash type matched to the helicopter.

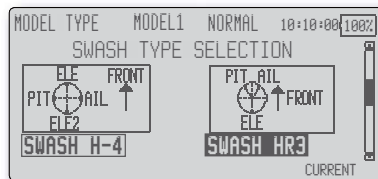
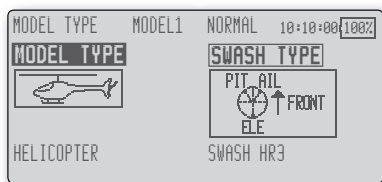

3. Flight condition addition

The transmitter can install up to eight flight conditions per model. You can assign all switches including sticks, switches, trim levers and trim switches as flight-condition selection switches. You can also add delayed mixing to these functions in order to avoid sudden changes. Moreover, you can set priority order for flight conditions when you set more than one condition. In addition, you can copy conditions and/or change names of conditions. This command may also be used to define what switches and/or controls are used to activate each flight condition.

The Condition Select function automatically allocates the Condition "NORMAL" for each model type. "NORMAL" is the default condition and is the only one active when a new model type is defined. This condition is always on, and remains on until other conditions are activated by switches.

The Condition Delay can be programmed for each channel. The Condition Delay is used to change the servo throw smoothly when switching conditions.

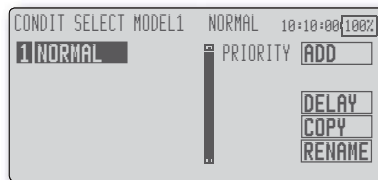

(General flight condition setting example)

- Normal: (Use initial setting conditions/operate when switch OFF)
Use from engine starting to hovering.
- Idle up 1: (Switch setting example: Operate at SW-E center)
Use in 540° stall turn, loop, rolling stall turn, and other maneuvers.
- Idle up 2: (Switch setting example: Operate at SW-E forward side)
Use in rolls.
- Throttle hold: (Switch setting example: Operate at SW-G forward side)
Use in auto rotation.

The priority is throttle hold/idle up 2/idle up 1/normal. Throttle hold has the highest priority.

Add other conditions, as required.

4. Fuselage linkage

Connect the throttle rudder, aileron, elevator, pitch, and other servos in accordance with the kit instruction manual. For a description of the connection method, see "Receiver and Servos Connection".

***The channel assignment of the T12Z is different from that of our existing systems. (The channel assigned to each function can be checked at the Function menu of the Linkage Menu.)**

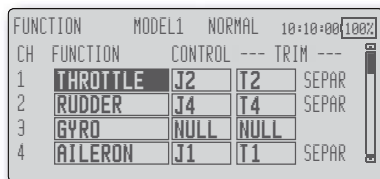

- If the direction of operation of the servo is incorrect, use the Reverse function of the Linkage Menu. Also use the swash AFR function in other than the H-1 mode.

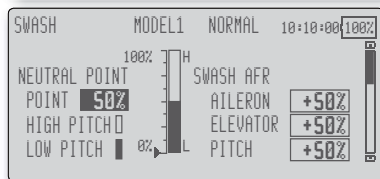
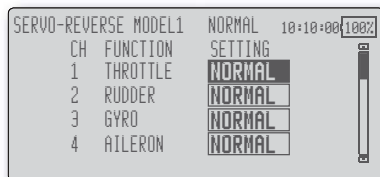

- Adjust the direction of operation of the gyro. (Gyro side function)
- Connect the throttle linkage so that the carburetor becomes full close at full trim throttle cut is possible.
- Adjust the neutral position at the linkage side and fine tune with the Sub-Trim function and End Point function (rudder angle adjustment). To protect the linkage, a limit position can also be set with the End Point function.

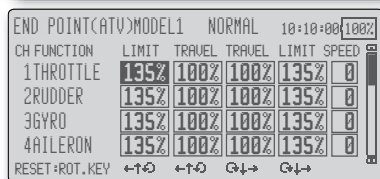
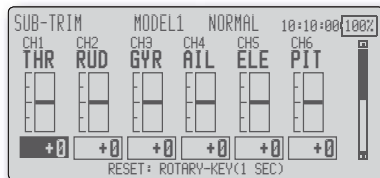

- Swash plate correction (Except H-1 mode)
Operation of the swash plate near the hovering point can be corrected by swash AFR function correction mixing. Use this when pitch, aileron, and elevator operation causes the swash plate to deviate from the normal direction.

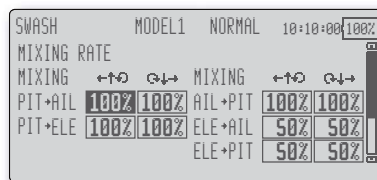

(Call the Swash setup→Mixing Rate/Linkage Compensation)
Pitch slow side and high side linkage correction is also possible. Adjust so that pitch operation causes the swash plate to move up and down in the horizontal state (Linkage Compensation.)

5. Throttle/Pitch curve setting

This function adjusts the throttle or pitch operation curve in relation to the movement of the throttle stick for each condition.

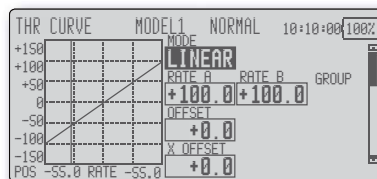

(17 points curve)

The throttle/pitch curve can be freely selected from linear operation curve to smooth curve, and adjusted to match the curve you want by means of the T12Z's powerful Curve Edit Function (6 types of curves can be selected). Up to 17 points can be set for linear or curve types. However, when using the 3 points or 5 points specified to create a curve, a simple and smooth curve can be created by selecting the curve type and reducing the number of input points to 3 or 5, and then entering the specified value at the corresponding points that you created.

<Throttle curve setting example>

Call the throttle curve of each condition with the condition select switch.

- Normal curve adjustment
Normal curve uses Normal (Linear) type and creates a basic pitch curve centered near hovering. This curve is adjusted together with the Throttle Curve (Normal) so that the engine speed is constant and up/down control is easiest.
- Idle up curve adjustment
The high side pitch curve sets the maximum pitch regardless of the engine load. The low side pitch curve creates a curve matched for aerobatics (loop, roll, 3D, etc.).

Note: When the curve type is changed, the data is reset.

- Throttle hold curve adjustment
The throttle hold curve is used when performing auto rotation dives.
Confirm that the rate of the slowest position (0%) of the stick is 0% (initial setting).
Be sure that when set to high side 100%, the curve of any condition does not exceed 100%.

<Example of pitch curve setting>

Call the pitch curve of each condition with the condition select switch.

- Pitch curve (Normal)
Make the pitch at hovering approximately +5°~6°. Set the pitch at hovering with the stick position at the 50% point as the standard.
*Stability at hovering may be connected to the throttle curve. Adjustment is easy by using the hovering throttle function and hovering pitch function together.
- Pitch curve (Idle up 1)
The idle up 1 pitch curve function creates a curve matched to airborne flight. Set to -7°~+12° as standard.
- Pitch curve (Idle up 2)
The high side pitch setting is less than idle up 1. The standard is +8°.
- Pitch curve (Hold)
At auto rotation, use the maximum pitch at both the high and low sides.
[Pitch angle setting example]
Throttle hold: -7°~+12°

6. Throttle hold setting

Call the Throttle Hold function from the Model Menu and switch to the throttle hold condition with the condition select switch.

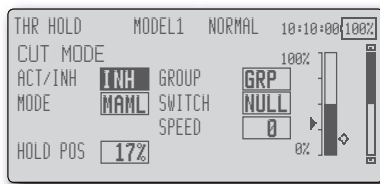

Note: At initial setting, the setting mode is the group mode. Since this function is not used at other conditions, switch to the single mode before setting.

- Setting to the state which activates the function
The throttle hold function allows setting for throttle cut and switching of the function fixed at the idle position by switch for training. Either one or both functions can be performed.
- Hold position setting
This function sets the servo operation position at throttle hold. (Throttle cut and idle positions)
- Other settings
When you want to link operation with stick manipulation, the Auto mode can be set.
When you want to adjust the servo speed, adjust [Speed].

7. Pitch to RUD mixing setting

Use this function when you want to suppress the torque generated by the changes in the pitch and speed of the main rotor during pitch operation. Adjust it so that the nose does not swing in the rudder direction. However, when using a heading hold gyro like those shown below, do not use Pitch to RUD mixing.

Note: When using a GY601, GY502, GY401, or other heading hold gyro, this Pitch to RUD mixing should not be used. The reaction torque is corrected at the gyro side. When operating the gyro in the AVCS mode, the mixed signal will cause neutral deviation symptoms and the gyro will not operate normally.

Call the Pitch to RUD mixing function from the Model Menu, and set the curve for each condition. (At initial setting, this function is in the "INH" state. To use it, set it to the "ON" state.)

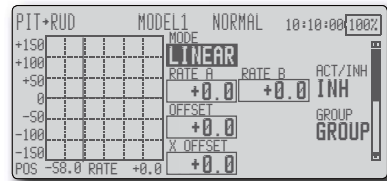

(17 points curve)

Curve setting of up to 17 points is possible. However, in the following setting example, a simple curve can be adjusted by using the [Linear] curve type.

Note: At initial setting, the setting mode is the group mode. In this mode, the same contents are set at in all conditions. When you want to set the selected condition only, switch to the single mode.

<Setting example>

Call the mixing curve of each condition with the condition select switch.

1. A curve setting example is shown below.

- Pitch to RUD mixing curve (Normal)
Use the hovering system and set this curve to match take off and landing and vertical climb at a constant speed.
*For this curve, use the initial setting [Linear] curve type.
- Pitch to RUD mixing (Idle up 1)
Use this curve in 540° stall turn, loop, and rolling stall turn, and adjust it so the fuselage is facing straight ahead when heading into the wind.
*For this curve, [Linear] curve type can be used and the entire curve can be lowered with the [Offset] function.
- Pitch to RUD mixing (Hold)
This function is set so that the fuselage is facing

straight ahead at straight line auto rotation. The pitch of the tail rotor becomes nearly 0°.

*For this curve, [Linear] curve type can be used and the entire curve can be lowered with the [Offset] function.

- Other settings

The mixing rise characteristic at pitch operation can be adjusted. An acceleration function and deceleration function, which temporarily increase and decrease the mixing amount, can be set.

8. Swash Mix corrects aileron, elevator and pitch interaction

The swash mix function is used to correct the swash plate in the aileron (roll) direction and elevator (cyclic pitch) corresponding to each operation of each condition.

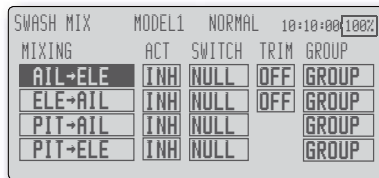

9. Throttle mixing setting

RPM loss caused by swash operation at aileron or elevator operation can be corrected with the Throttle Mix function of the Model Menu. How clockwise and counterclockwise torque is applied when pirouetting can also be corrected.

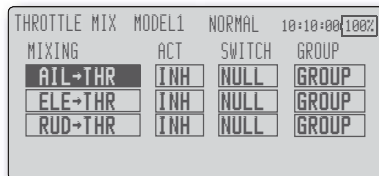

10. Gyro sensitivity and mode switching

The gyro sensitivity and mode switching function is dedicated gyro mixing of the Model Menu, and can be set for each condition.

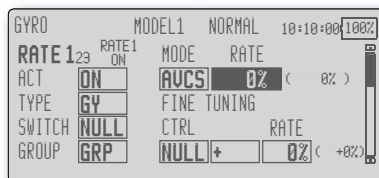

- Normal condition (hovering): Gyro sensitivity maximum
- Idle up 1/Idle up 2/Throttle hold: Gyro sensitivity minimum
- However, at auto rotation of a tail-driven helicopter, this function may not have any affect at high gyro sensitivity.

11. Throttle cut setting

Throttle cut provides an easy way to stop the engine, by flipping a switch with the throttle stick at idle. The action is not functional at high throttle to avoid accidental dead sticks. The switch's location and direction must be chosen, as it defaults to NULL.

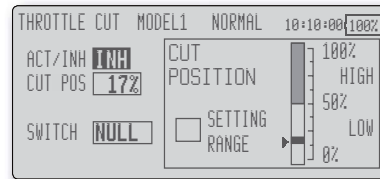

*With throttle stick at idle, adjust the cut position until the engine consistently shuts off, but throttle linkage is not binding. When finished, push the return key to exit.

12. Other special mixings

- Pitch to Needle mixing
This mixing is used with engines with a construction which allows needle control during flight (fuel-air mixture adjustment). A needle curve can be set. The needle servo rise characteristics at throttle stick acceleration/deceleration operation can be adjusted. (Acceleration function)
- Fuel mixture function
This mixing is used in needle adjustment of engines which use a fuel mixture control carburetor.
- Governor mixing
This mixing is dedicated governor mixing when a GV-1 (governor) is used. Up to 3 rates (speeds) can be switched for each condition.

Receiver and servo connection

Connect the receiver and servos in accordance with the connection diagram shown below. Always read [Precautions when mounting the receiver and servos] of [Before using]. When mounting the receiver and servos to the fuselage, connect the necessary points in accordance with the kit instruction manual.

Receiver and servos connection diagram

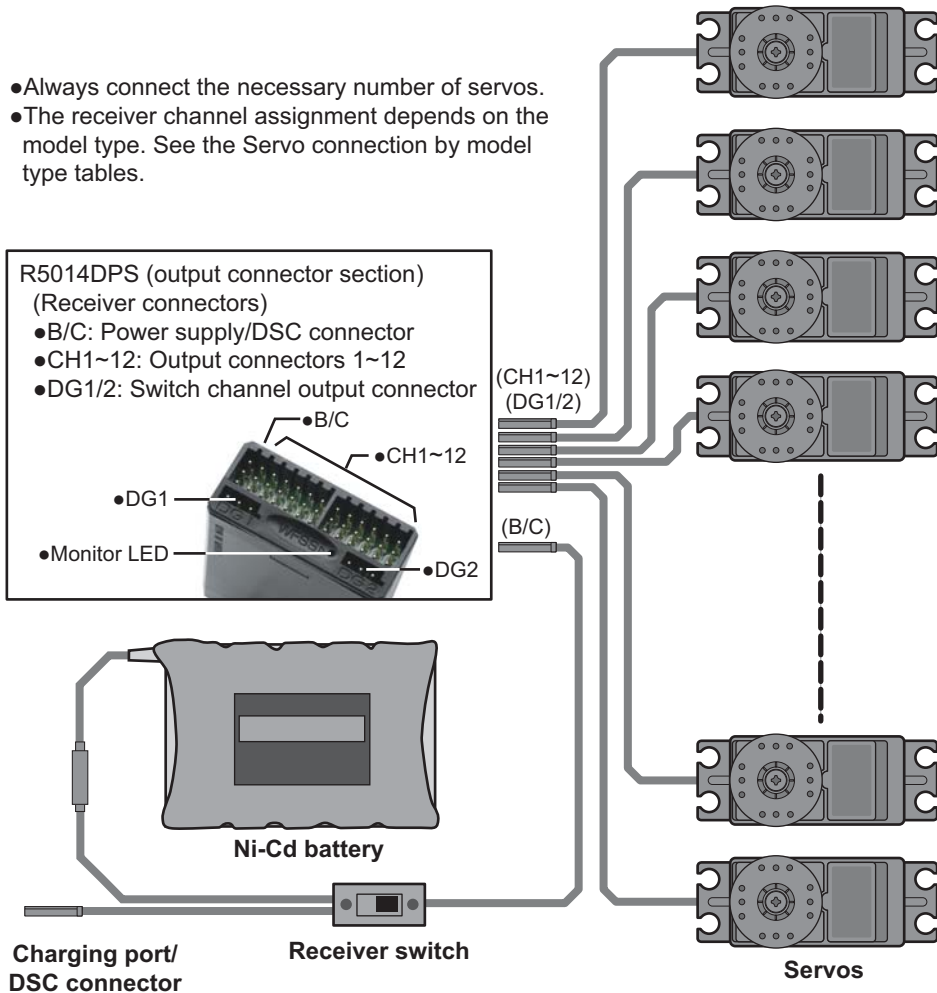

The Servo connection by model type tables are shown on the following pages. Connect the servos to match the fuselage used.

Servo connection by model type

The T12Z transmitter channels are automatically assigned for optimal combination according to the type selected with the Model Type function of the Linkage Menu. The channel assignment (initial setting) for each model type is shown below. Connect the receiver and servos to match the type used.

*The set channels can be checked at the Function screen of the Linkage Menu. The channel assignments can also be changed. For more information, read the description of the Function menu.

Airplane/glider/motor glider

● Airplane and V tail

RX CH	1AIL			2AIL			2AIL+1FLAP			2AIL+2FLAP		
	Airplane	Glider		Airplane	Glider		Airplane	Glider		Airplane	Glider	
		EP			EP			EP			EP	
1	Elevator	Elevator	Elevator	Elevator	Elevator	Elevator	Elevator	Elevator	Elevator	Elevator	Elevator	Elevator
2	Rudder	Rudder	Rudder	Rudder	Rudder	Rudder	Rudder	Rudder	Rudder	Rudder	Rudder	Rudder
3	Throttle	Motor	AUX1	Throttle	Motor	AUX1	Throttle	Motor	AUX7	Throttle	Motor	AUX6
4	Aileron	Aileron	Aileron	Aileron	Aileron	Aileron	Aileron	Aileron	Aileron	Aileron	Aileron	Aileron
5	Gear	AUX7	AUX7	Aileron2	Aileron2	Aileron2	Aileron2	Aileron2	Aileron2	Aileron2	Aileron2	Aileron2
6	Airbrake	Airbrake	Airbrake	Gear	AUX7	AUX7	Flap	Flap	Flap	Gear	AUX5	AUX5
7	AUX6	AUX6	AUX6	AUX6	AUX6	AUX6	Gear	AUX6	AUX6	Flap	Flap	Flap
8	AUX5	AUX5	AUX5	AUX5	AUX5	AUX5	AUX5	AUX5	AUX5	Flap2	Flap2	Flap2
9	AUX4	AUX4	AUX4	AUX4	AUX4	AUX4	AUX4	AUX4	AUX4	AUX4	AUX4	AUX4
10	AUX3	AUX3	AUX3	AUX3	AUX3	AUX3	AUX3	AUX3	AUX3	AUX3	AUX3	AUX3
11	AUX2	AUX2	AUX2	AUX2	AUX2	AUX2	AUX2	AUX2	AUX2	AUX2	AUX2	AUX2
12	AUX1	AUX1	AUX1	AUX1	AUX1	AUX1	AUX1	AUX1	AUX1	AUX1	AUX1	AUX1
VC1	AUX1	AUX1	AUX1	Camber	Camber	Camber	Camber	Camber	Camber	Camber	Camber	Camber
VC2	AUX1	AUX1	AUX1	AUX1	Butterfly	Butterfly	AUX1	Butterfly	Butterfly	AUX1	Butterfly	Butterfly
VC3	AUX1	AUX1	AUX1	AUX1	AUX1	AUX1	AUX1	AUX1	AUX1	AUX1	AUX1	AUX1
VC4	AUX1	AUX1	AUX1	AUX1	AUX1	AUX1	AUX1	AUX1	AUX1	AUX1	AUX1	AUX1

- When a receiver other than the PCM-G3 type is used, only the shaded part of the table above is valid.
- VC1~4 are vertical channels without receiver output. For more information, see the description of the Function menu of the Linkage Menu.

RX CH	2AIL+4FLAP			4AIL+2FLAP			4AIL+4FLAP		
	Airplane	Glider		Airplane	Glider		Airplane	Glider	
		EP			EP			EP	
1	Elevator	Elevator	Elevator	Elevator	Elevator	Elevator	Elevator	Elevator	Elevator
2	Rudder	Rudder	Rudder	Rudder	Rudder	Rudder	Rudder	Rudder	Rudder
3	Throttle	Motor	AUX4	Throttle	Motor	AUX4	Throttle	Motor	AUX2
4	Aileron	Aileron	Aileron	Aileron	Aileron	Aileron	Aileron	Aileron	Aileron
5	Aileron2	Aileron2	Aileron2	Aileron2	Aileron2	Aileron2	Aileron2	Aileron2	Aileron2
6	Gear	AUX3	AUX3	Gear	AUX3	AUX3	Gear	AUX1	AUX1
7	Flap	Flap	Flap	Aileron3	Aileron3	Aileron3	Aileron3	Aileron3	Aileron3
8	Flap2	Flap2	Flap2	Aileron4	Aileron4	Aileron4	Aileron4	Aileron4	Aileron4
9	Flap3	Flap3	Flap3	Flap1	Flap1	Flap1	Flap1	Flap1	Flap1
10	Flap4	Flap4	Flap4	Flap2	Flap2	Flap2	Flap2	Flap2	Flap2
11	AUX2	AUX2	AUX2	AUX2	AUX2	AUX2	Flap3	Flap3	Flap3
12	AUX1	AUX1	AUX1	AUX1	AUX1	AUX1	Flap4	Flap4	Flap4
VC1	Camber	Camber	Camber	Camber	Camber	Camber	Camber	Camber	Camber
VC2	AUX1	Butterfly	Butterfly	AUX1	Butterfly	Butterfly	AUX1	Butterfly	Butterfly
VC3	AUX1	AUX1	AUX1	AUX1	AUX1	AUX1	AUX1	AUX1	AUX1
VC4	AUX1	AUX1	AUX1	AUX1	AUX1	AUX1	AUX1	AUX1	AUX1

●Ailvator

RX CH	1AIL			2AIL			2AIL+1FLAP			2AIL+2FLAP		
	Airplane	Glider		Airplane	Glider		Airplane	Glider		Airplane	Glider	
		EP			EP			EP			EP	
1	Elevator	Elevator	Elevator	Elevator	Elevator	Elevator	Elevator	Elevator	Elevator	Elevator	Elevator	Elevator
2	Elevator2	Elevator2	Elevator2	Elevator2	Elevator2	Elevator2	Elevator2	Elevator2	Elevator2	Elevator2	Elevator2	Elevator2
3	Rudder	Rudder	Rudder	Rudder	Rudder	Rudder	Rudder	Rudder	Rudder	Rudder	Rudder	Rudder
4	Aileron	Aileron	Aileron	Aileron	Aileron	Aileron	Aileron	Aileron	Aileron	Aileron	Aileron	Aileron
5	Throttle	Motor	AUX7	Aileron2	Aileron2	Aileron2	Aileron2	Aileron2	Aileron2	Aileron2	Aileron2	Aileron2
6	Airbrake	Airbrake	Airbrake	Throttle	Motor	AUX7	Throttle	Motor	AUX6	Throttle	Motor	AUX5
7	Gear	AUX6	AUX6	Gear	AUX6	AUX6	Flap	Flap	Flap	Flap	Flap	Flap
8	AUX5	AUX5	AUX5	AUX5	AUX5	AUX5	Gear	AUX5	AUX5	Flap2	Flap2	Flap2
9	AUX4	AUX4	AUX4	AUX4	AUX4	AUX4	AUX4	AUX4	AUX4	Gear	AUX4	AUX4
10	AUX3	AUX3	AUX3	AUX3	AUX3	AUX3	AUX3	AUX3	AUX3	AUX3	AUX3	AUX3
11	AUX2	AUX2	AUX2	AUX2	AUX2	AUX2	AUX2	AUX2	AUX2	AUX2	AUX2	AUX2
12	AUX1	AUX1	AUX1	AUX1	AUX1	AUX1	AUX1	AUX1	AUX1	AUX1	AUX1	AUX1
VC1	AUX1	AUX1	AUX1	Camber	Camber	Camber	Camber	Camber	Camber	Camber	Camber	Camber
VC2	AUX1	AUX1	AUX1	AUX1	Butterfly	Butterfly	AUX1	Butterfly	Butterfly	AUX1	Butterfly	Butterfly
VC3	AUX1	AUX1	AUX1	AUX1	AUX1	AUX1	AUX1	AUX1	AUX1	AUX1	AUX1	AUX1
VC4	AUX1	AUX1	AUX1	AUX1	AUX1	AUX1	AUX1	AUX1	AUX1	AUX1	AUX1	AUX1

- When a receiver other than the PCM-G3 type is used, only the shaded part of the table above is valid.
- VC1~4 are vertical channels without a receiver output. For more information, see the description of the Function menu of the Linkage Menu.

RX CH	2AIL+4FLAP			4AIL+2FLAP			4AIL+4FLAP		
	Airplane	Glider		Airplane	Glider		Airplane	Glider	
		EP			EP			EP	
1	Elevator	Elevator	Elevator	Elevator	Elevator	Elevator	Elevator	Elevator	Elevator
2	Elevator2	Elevator2	Elevator2	Elevator2	Elevator2	Elevator2	Elevator2	Elevator2	Elevator2
3	Rudder	Rudder	Rudder	Rudder	Rudder	Rudder	Rudder	Rudder	Rudder
4	Aileron	Aileron	Aileron	Aileron	Aileron	Aileron	Aileron	Aileron	Aileron
5	Aileron2	Aileron2	Aileron2	Aileron2	Aileron2	Aileron2	Aileron2	Aileron2	Aileron2
6	Throttle	Motor	AUX7	Throttle	Motor	AUX3	Throttle	Motor	AUX1
7	Flap	Flap	Flap	Aileron3	Aileron3	Aileron3	Aileron3	Aileron3	Aileron3
8	Flap2	Flap2	Flap2	Aileron4	Aileron4	Aileron4	Aileron4	Aileron4	Aileron4
9	Flap3	Flap3	Flap3	Flap1	Flap1	Flap1	Flap1	Flap1	Flap1
10	Flap4	Flap4	Flap4	Flap2	Flap2	Flap2	Flap2	Flap2	Flap2
11	Gear	AUX2	AUX2	Gear	AUX2	AUX2	Flap3	Flap3	Flap3
12	AUX1	AUX1	AUX1	AUX1	AUX1	AUX1	Flap4	Flap4	Flap4
VC1	Camber	Camber	Camber	Camber	Camber	Camber	Camber	Camber	Camber
VC2	AUX1	Butterfly	Butterfly	AUX1	Butterfly	Butterfly	AUX1	Butterfly	Butterfly
VC3	AUX1	AUX1	AUX1	AUX1	AUX1	AUX1	AUX1	AUX1	AUX1
VC4	AUX1	AUX1	AUX1	AUX1	AUX1	AUX1	AUX1	AUX1	AUX1

●Tailless wing

RX CH	2AIL			2AIL+1FLAP			2AIL+2FLAP		
	Airplane	Glider		Airplane	Glider		Airplane	Glider	
		EP			EP			EP	
1	Rudder	Rudder	Rudder	Rudder	Rudder	Rudder	Rudder	Rudder	Rudder
2	Rudder2	Rudder2	Rudder2	Rudder2	Rudder2	Rudder2	Rudder2	Rudder2	Rudder2
3	Throttle	Motor	AUX1	Throttle	Motor	AUX7	Throttle	Motor	AUX6
4	Aileron	Aileron	Aileron	Aileron	Aileron	Aileron	Aileron	Aileron	Aileron
5	Aileron2	Aileron2	Aileron2	Aileron2	Aileron2	Aileron2	Aileron2	Aileron2	Aileron2
6	Gear	AUX7	AUX7	Flap	Flap	Flap	Gear	AUX5	AUX5
7	AUX6	AUX6	AUX6	Gear	AUX6	AUX6	Flap	Flap	Flap
8	AUX5	AUX5	AUX5	AUX5	AUX5	AUX5	Flap2	Flap2	Flap2
9	AUX4	AUX4	AUX4	AUX4	AUX4	AUX4	AUX4	AUX4	AUX4
10	AUX3	AUX3	AUX3	AUX3	AUX3	AUX3	AUX3	AUX3	AUX3
11	AUX2	AUX2	AUX2	AUX2	AUX2	AUX2	AUX2	AUX2	AUX2
12	AUX1	AUX1	AUX1	AUX1	AUX1	AUX1	AUX1	AUX1	AUX1
VC1	Elevator	Elevator	Elevator	Elevator	Elevator	Elevator	Elevator	Elevator	Elevator
VC2	AUX1	AUX1	AUX1	Camber	Camber	Camber	Camber	Camber	Camber
VC3	AUX1	AUX1	AUX1	AUX1	Butterfly	Butterfly	AUX1	Butterfly	Butterfly
VC4	AUX1	AUX1	AUX1	AUX1	AUX1	AUX1	AUX1	AUX1	AUX1

- When a receiver other than the PCM-G3 type is used, only the shaded part of the table above is valid.
- VC1~4 are vertical channels without a receiver output. For more information, see the description of the Function menu of the Linkage Menu.

RX CH	2AIL+4FLAP			4AIL+2FLAP			4AIL+4FLAP		
	Airplane	Glider		Airplane	Glider		Airplane	Glider	
		EP			EP			EP	
1	Rudder	Rudder	Rudder	Rudder	Rudder	Rudder	Rudder	Rudder	Rudder
2	Rudder2	Rudder2	Rudder2	Rudder2	Rudder2	Rudder2	Rudder2	Rudder2	Rudder2
3	Throttle	Motor	AUX4	Throttle	Motor	AUX4	Throttle	Motor	AUX2
4	Aileron	Aileron	Aileron	Aileron	Aileron	Aileron	Aileron	Aileron	Aileron
5	Aileron2	Aileron2	Aileron2	Aileron2	Aileron2	Aileron2	Aileron2	Aileron2	Aileron2
6	Gear	AUX3	AUX3	Gear	AUX3	AUX3	Gear	AUX1	AUX1
7	Flap	Flap	Flap	Aileron3	Aileron3	Aileron3	Aileron3	Aileron3	Aileron3
8	Flap2	Flap2	Flap2	Aileron4	Aileron4	Aileron4	Aileron4	Aileron4	Aileron4
9	Flap3	Flap3	Flap3	Flap1	Flap1	Flap1	Flap1	Flap1	Flap1
10	Flap4	Flap4	Flap4	Flap2	Flap2	Flap2	Flap2	Flap2	Flap2
11	AUX2	AUX2	AUX2	AUX2	AUX2	AUX2	Flap3	Flap3	Flap3
12	AUX1	AUX1	AUX1	AUX1	AUX1	AUX1	Flap4	Flap4	Flap4
VC1	Elevator	Elevator	Elevator	Elevator	Elevator	Elevator	Elevator	Elevator	Elevator
VC2	Camber	Camber	Camber	Camber	Camber	Camber	Camber	Camber	Camber
VC3	AUX1	Butterfly	Butterfly	AUX1	Butterfly	Butterfly	AUX1	Butterfly	Butterfly
VC4	AUX1	AUX1	AUX1	AUX1	AUX1	AUX1	AUX1	AUX1	AUX1

Helicopter

CH	H-4 Swash	All Other
1	Throttle	Throttle
2	Rudder	Rudder
3	Aileron	Gyro
4	Elevator 1	Aileron
5	Pitch	Elevator
6	Elevator 2	Pitch
7	Gyro	Governor 1
8	Governor 1	Governor 2
9	Governor 2	Needle
10	Needle	AUX3
11	AUX2	AUX2
12	AUX1	AUX1
VC1	AUX1	AUX1
VC2	AUX1	AUX1
VC3	AUX1	AUX1
VC4	AUX1	AUX1

- When a receiver other than the PCM-G3 type is used, only the shaded part of the table at the left is valid.
- VC1~4 are vertical channels with no receiver output. For more information, see the description of the Function menu of the Linkage Menu.

FUNCTIONS OF LINKAGE MENU

The Linkage Menu is made up of functions which perform model addition, model type selection, frequency setting, end point setting, and other model basic settings.

The functions which can be selected depend on the model type. A typical menu screen is shown below.

- Select [LINKAGE] at the home screen and call the linkage menu shown below by pushing the enter button.
- Use the cursor lever to select the function you want to set and call the setup screen by pushing the enter button..

*The display screen is an example. The screen depends on the model type.

- [Return Key]**
- To home screen
 - To preceding screen

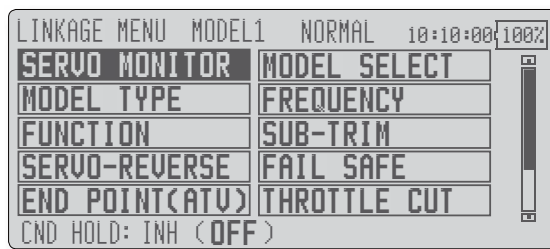

- [Cursor Lever]**
- Movement on the screen (4 directions)
 - Push the lever to call next page.
- [Data Input Dial]**
- [Enter Button]**

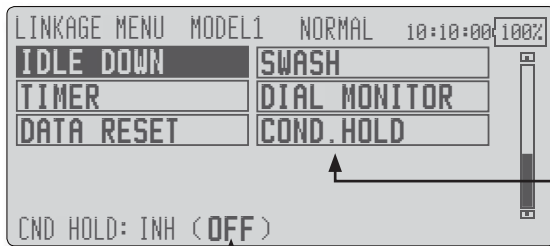

*Condition hold operation is displayed.

To activate/deactivate Condition Hold:

(Helicopter type only)

1. Move the cursor to [COND. HOLD].
2. Set the throttle stick lower than the 1/3 point and push the enter button to activate/deactivate the condition hold function.

*See p.68 for condition hold function details.

Linkage Menu functions table

- [SERVO MONITOR]: Displays the servo test and operation position
- [MODEL SELECT]: Model addition, call, deletion, copy, model name setting
- [MODEL TYPE]: Model type, wing type, switch type, etc. selection
- [FREQUENCY]: Frequency selection, modulation mode selection, receiver ID setting
- [FUNCTION]: Channel assignment of each function can be changed
- [SUB-TRIM]: Adjusts the neutral position of each servo
- [SERVO-REVERSE]: Servo direction reversal
- [FAIL SAFE]: Fail safe function and battery fail safe function setting
- [END POINT(ATV)]: Servo basic rudder adjustment and limit setting
- [THROTTLE CUT]: Stops the engine safely and easily (airplane and helicopter only)
- [IDLE DOWN]: Lowers the idle speed of the engine (airplane and helicopter only)
- [SWASH]: Swash AFR and linkage correction function (helicopter only)
- [TIMER]: Timer setting and lap time display
- [DIAL MONITOR]: Dial, sliding lever, and digital trim position display
- [DATA RESET]: Model memory set data reset (by item)
- [COND. HOLD]: Condition hold function

SERVO MONITOR

Servo Test & Graph Display / Displays servo positions.

This is used for testing servo movement. “Moving Test” (repetition mode) and “Neutral Test” (fixed position mode) are available.

The “Neutral test” is good for finding the neutral position of a servo horn.

- Select [SERVO MONITOR] at the linkage menu and call the setup screen shown below by pushing the enter button.

[Return Key]

- To home screen
- To preceding screen

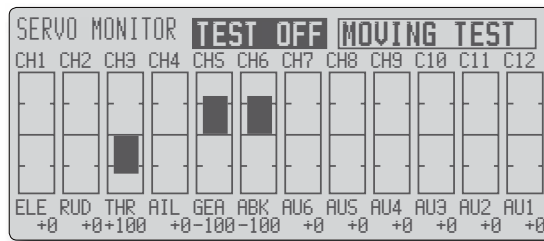

[Cursor Lever]

- Movement on the screen (4 directions)
- Push the lever to call next page.

[Data Input Dial]

[Enter Button]

*The display screen is an example. The screen depends on the model type.

Servo test operation

1. Use the cursor lever to move the cursor to the test mode display position and select the test mode by turning the data input dial to the left or right.
[MOVING TEST]: Mode which repeats operation of each servo
[NEUTRAL TEST]: Mode which locks each servo in the neutral position
2. Use the cursor lever to move the cursor to the [TEST OFF] position. When the enter button is pushed, testing starts.
3. When the enter button is pushed in the state in which [TEST ON] is displayed, testing is stopped.

MODEL SELECT

The Model Selection function performs model addition, call, deletion, copy, and model name setting.

This function is used to load the settings of the desired model into the T12Z's memory.

The settings may be selected from either the transmitter's built-in memory or a CFDP32M (Compact Flash card; 32MB). Remember that up to 25 model memories are available in the transmitter.

The name of the model stored in the transmitter and the CF card may be changed. This can be very useful to tell different models settings apart. Each model name can be as long as 8 characters, and the model name

- Select [MODEL SELECT] at the linkage menu and call the setup screen shown below by pushing the enter button.

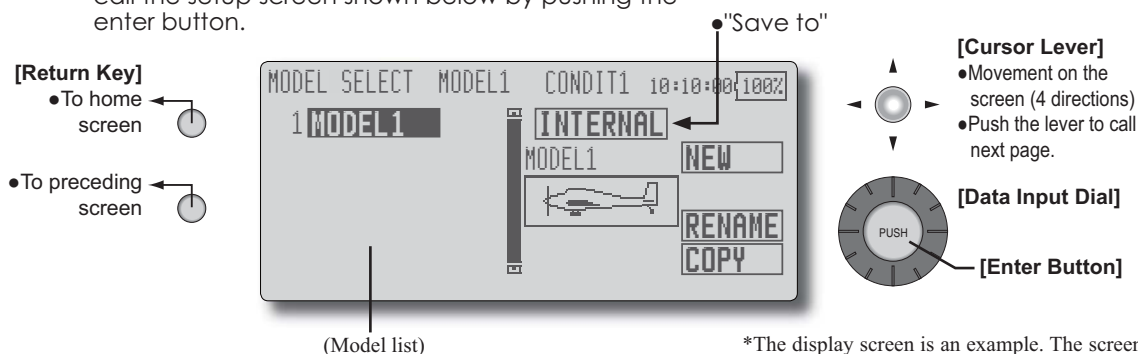

Model call

*Model data saved at models other than the model currently used or saved on a CF card can be called.

1. Use the cursor lever to move to the save destination ("INTERNAL" or "MEM.CARD") and select the location which is to save the desired model by turning the data input dial to the left or right.

[INTERNAL]: Transmitter memory

[MEM. CARD]: CF card

2. After using the cursor lever to move the cursor to the desired model in the model list, push the enter button.
3. Use the cursor lever to move to [SELECT].
4. Push the enter button. When a confirmation message is displayed and the enter button is pushed again, calling is complete.

*Transmission stops and a send with new model confirmation message ("TRANSMIT?") appears.

5. To start transmission, use the cursor lever to select [YES] and then push the enter button. To not transmit, select [NO] and push the enter button.

always appears in the display screen.

The Copy function is used to copy one set of model data into a second memory within the transmitter and the CF card. It may be used for getting a head-start on setting up models with almost the same settings (only differences need to be modified, instead of entering the complete model from scratch). Also, this function may be used to make a backup copy of a model setup before any changes are made.

Model addition

*A new model can be added to the transmitter memory or CF card.

1. Use the cursor lever to move the cursor to the save destination ("INTERNAL" or "MEM. CARD") and select the save destination by turning the data input dial to the left or right.

[INTERNAL]: Transmitter memory

[MEM. CARD]: CF card

2. Use the cursor lever to move to [NEW].
3. Press the enter button. A confirmation message appears. Press the enter button again.

*The model type setup screen and frequency setup screen are automatically displayed. Confirm or change the model type and frequency.

*A starting transmission with new model confirmation message ("TRANSMIT") appears.

4. To start transmission, use the cursor level to select [YES] and then push the enter button. To not transmit, select [NO] and push the enter button.

*The added model appears in the model list.

Model deletion

*The model stored in the transmitter memory or a CF card can be deleted.

1. Use the cursor lever to move the cursor to the save destination display ("INTERNAL" or "MEM. CARD") and select the save destination by turning the data input dial to the left or right.
[INTERNAL]: Transmitter memory
[MEM. CARD]: CF card
2. Use the cursor lever to move the cursor to the model you want to delete in the model list and then push the enter button.
3. Use the cursor and move to [DELETE].
4. Push the enter button. When a confirmation message is displayed and the enter button is pushed again, the model is deleted.

Model name change

*The model name saved in the transmitter memory or a CF card can be changed.

1. Use the cursor lever to move to the save destination display ("INTERNAL" or "MEM. CARD") and select the save destination by turning the data input dial to the left or right.
[INTERNAL]: Transmitter memory
[MEM. CARD]: CF card
2. Use the cursor lever to select the model in the model list and then push the enter button.
3. Use the cursor lever to move to [RENAME].
4. Push the enter button.

*The model name setup screen is displayed.

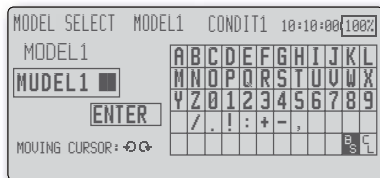

5. Use the data input dial to select the character to be changed in the model name, Use the cursor lever to select the candidate character and then push the enter button. Change the other characters in the same way.

*A name of up to 8 characters can be entered as a model name. (Space is also counted as one character.)

*[BS] erases the character at the cursor position and [CL] erases the character at the cursor position and all the following characters.

6. At the end of input, use the cursor lever to select [ENTER] and then push the enter button.

*When you want to stop input and return to the original state, select [CANCEL] and push the enter button.

7. Push the return key to return to the original screen.

Model copy

*A copy can be made of the model saved in the transmitter memory or a CF card.

1. Use the cursor lever to move the cursor to the save destination display ("INTERNAL" or "MEM. CARD") and select the copy source model save location by turning the data input dial to the left or right.
[INTERNAL]: Transmitter memory
[MEM. CARD]: CF card
2. Move to [COPY] with the cursor lever.
3. Push the enter button.

*The copy screen appears.

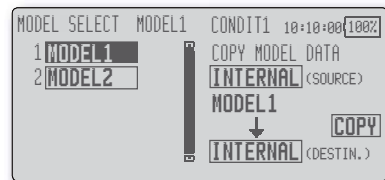

4. Use the cursor lever to move the cursor to the copy source model in the model list and then push the enter key.
5. Use the cursor lever to move to the copy destination position at the bottom of the screen. Select the save destination by turning the data input dial.
6. Use the cursor lever to move to [COPY].
7. Push the enter button. When a confirmation message is displayed and the enter button is pushed again, the model data is copied.

MODEL TYPE

This function selects the model type from among airplane, helicopter, and glider.

Seven types of main wings and three types of tail wings are available for airplanes. Seven swash types are available for helicopters. Seven types of main wings and three types of tail wings are available for gliders. Functions and mixing functions necessary for each model type are set in advance at the factory.

Note: The Model Type function automatically selects the appropriate output channels, control functions, and mixing functions for the chosen model type. When the Model Type Selection command is accessed, all of the data in the active memory is cleared. Be sure that you don't mind losing this data, or back it up to another memory using the copying functions.

- Select [MODEL TYPE] at the linkage menu and call the setup screen shown below by pushing the enter button.

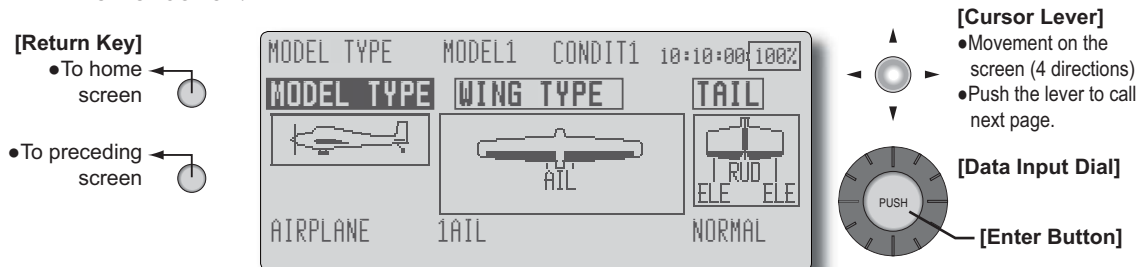

(The display screen is an example. The screen depends on the model type.)

Model type selection

1. Use the cursor lever to move the cursor to the item you want to change and then call the selection screen by pushing the enter button.
 - "MODEL TYPE"
 - "WING TYPE" (airplane/glider)
 - "TAIL" (airplane/glider)
 - "SWASH TYPE" (helicopter)
2. Use the cursor lever to move the cursor (blinking) to the type you want to change and select the type by pushing the enter button.

*When the model type was changed, the wing type, tail type, or swash type selection screens sequentially appear according to the model. Finally, the blinking confirmation message "MODEL TYPE CONFIRMATION" appears.

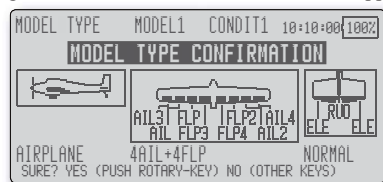

3. Push the enter button to execute the change. (Operate another key to stop the change.)

*The model types which are displayed (which can be selected) depend on the type of receiver used. For instance, for the R149DP, only model types compatible with CH8 can be selected. See Servo Connection by Model Type (pages 44-47).

• Model type selection

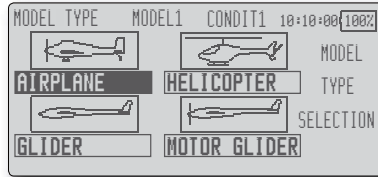

Model type
Select the model type from among airplane, helicopter, glider, and motor glider.

(Airplane, glider)

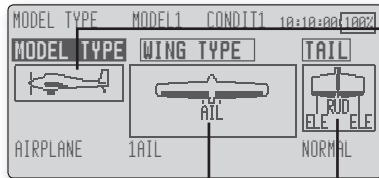

(Helicopter)

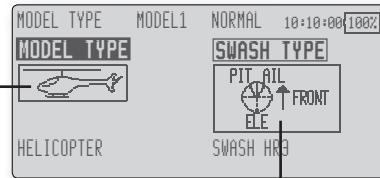

• Wing type selection (1/2)

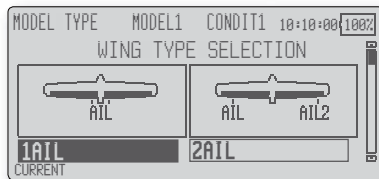

• Swash type selection

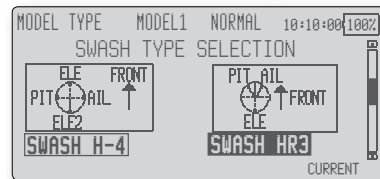

Helicopter swash type
Select from among H-1, H-2, H-4, HE3,HN3, and H-3.

• Wing type selection (2/2)

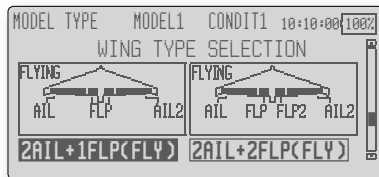

Wing type (1/2) (Normal)
Select from among :
1 aileron, 2 ailerons, 2 ailerons + 1 flap,
2 ailerons + 2 flaps, 2 ailerons + 4 flaps,
4 ailerons + 2 flaps, 4 ailerons + 4 flaps.

Wing type (2/2) (Tailless wing)
Selection from among:
2 ailerons, 2 ailerons + 1 flap,
2 ailerons + 2 flaps, 2 ailerons + 4 flaps,
4 ailerons + 2 flaps, 4 ailerons + 4 flaps.
*For tailless wing, the rudder type can be selected from normal rudder and winglet.

• Rudder type selection

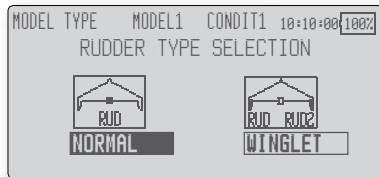

• Tail type selection

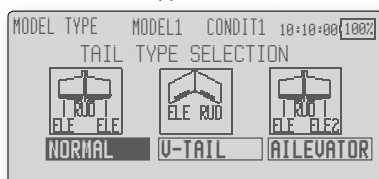

Tail type
Select from normal, V tail, and ailvator.

Frequency setting

The T12Z transmitter uses a synthesizer system. Its frequency can be changed within the range of the frequency band of the module used.

The frequency of the R5014DPS receiver is set from the transmitter. Use a receiver matched to the frequency band of the transmitter.

Receiver ID code

When the R5014DPS receiver (PCM-G3 receiver) is used, the ID code located on the back

- Select [FREQUENCY] at the linkage menu and call the setup screen shown below by pushing the enter button.

[Return Key]
• To home screen

• To preceding screen

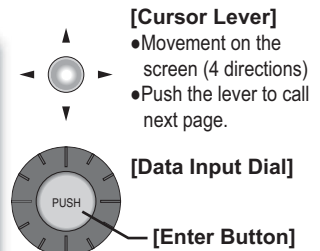
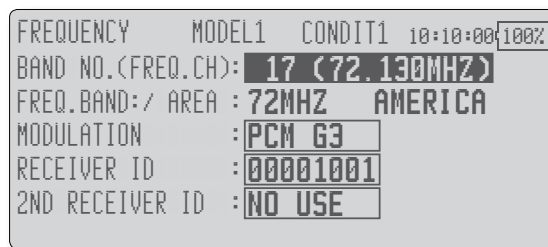

of the receiver case must be entered.

*When two receivers are used with a large model, etc., enter the 2nd receiver ID also.

Modulation mode selection

With the T12Z, 3 modulation modes (PCM-G3/PCM1024/PPM (FM)) can be selected. Select the modulation mode matched to the type of receiver used.

*After changing the modulation mode, switch the modulation mode by turning the transmitter power off and on.

Frequency switching method

For a description of the frequency switching and ID setting methods, refer to the procedure given in the Basic Operation section.

Modulation scheme (Modulation) change

1. Use the cursor lever to move the cursor to the "MODULATION" item and push the enter button.

*The modulation selection screen appears.

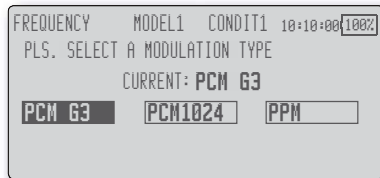

2. Use the cursor lever to select the mode and push the enter button.

*The confirmation message "MODUL.TYPE IS CHANGED. SURE?" appears.

3. When the enter button is pressed again, the mode is changed.

*Transmission stops and a transmit or do not transmit in the new mode confirmation message "TRANSMIT?" appears.

4. To start transmission, select [YES] with the cursor lever and push the enter button. To not transmit, select [NO] and push the enter button.

*When the mode is changed from the PCM-G3 mode to another mode and the number of channels is insufficient due to the wing type used, the mode cannot be changed.

Receiver ID code input

*Input the 8-digit ID number indicated on the receiver case.

1. Use the cursor lever to select [RECEIVER ID] and push the enter key. The receiver ID code setup screen appears.

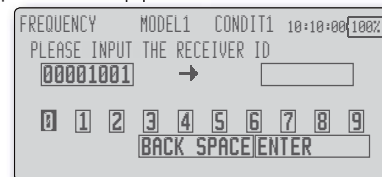

2. Use the cursor lever to select the candidate character of the first digit and push the enter key. Sequentially set the 8-digit number.

*If you make a mistake, select [BACK SPACE] with the cursor lever and erase the incorrect digit by pressing the enter button.

5. At the end of input, select [ENTER] and push the enter button.

*Once the ID code is set, re-setting is unnecessary as long as the receiver is not changed.

⚠ WARNING

! When flying after frequency change, emit radio waves only after verifying the frequency.

*Also change the frequency clip. Emitting radio waves without verification is extremely dangerous.

When you select model and wing (swash) types, you will find that the optimized combinations of servo output channels and functions have been already preset. If you would like, you can freely change combinations of servo output channels, functions (aileron, elevator, etc), and input controllers (sticks, switches, trim levers and trim switches).

*You can also assign the same function to multiple servo output channels such as assigning elevator function to CH2 and CH3.

Note: In PCMG3 mode, combinations of three channels such as CH 1 through CH 3, CH 4 through CH 6, CH 7 through CH 9 and CH 10 through CH 12 work simultaneously. Futaba recommends that you use the standard optimized default combinations of channels and functions in order to minimize servo delay when you use multiple servos to control models such as swash mode helicopters and dual elevator airplanes or flaperon airplanes.

VC1~VC4 (virtual channels)

These four channels can be set as virtual functions that do not have servo output channels. You can freely change combinations between functions (aileron, elevator, etc) and input controllers (sticks, switches, trim levers and trim switches).

Servo Output Channels

For PCMG3 mode, you can set twelve linear channels. For PCM1024 mode, you can set eight linear channels and one digital channel. For PPM mode, you can set only eight linear channels.

*DG1 (switch channels)

This channel can be used as switch channels. You can freely change combinations between servo output channels and input controllers (sticks, switches, trim levers and trim switches).

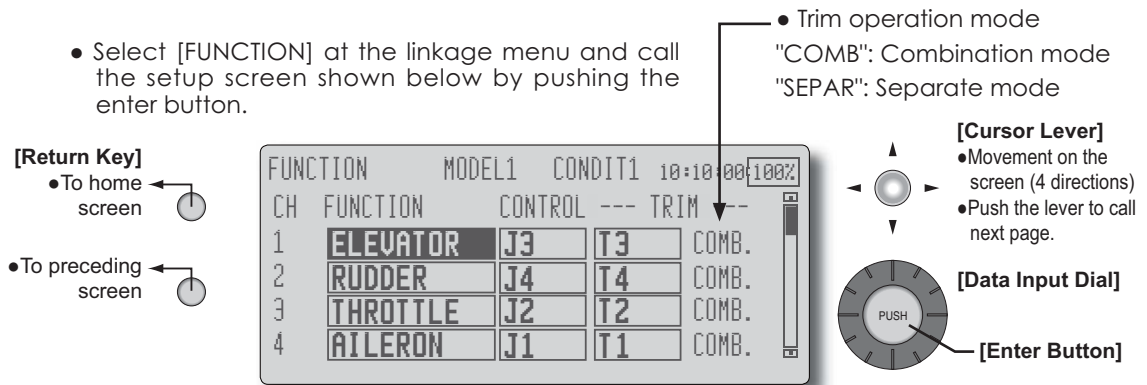

(The display screen is an example. The screen depends on the model type.)

Function change

1. Use the cursor lever to move the cursor to the "FUNCTION" item of the channel you want to change and push the enter button.

*The function selection screen is displayed.

2. Use the cursor lever to move the cursor to the function name you want to set and push the enter button.

*The function name blinks.

3. Push the enter button to execute the change. (When you want to cancel this operation, operate another key.)

*Multiple channels can be assigned to one function.

Operation control change

1. Use the cursor lever to move the cursor to the "CONTROL" item of the channel you want to change and push the enter button.

*The control selection screen is displayed.

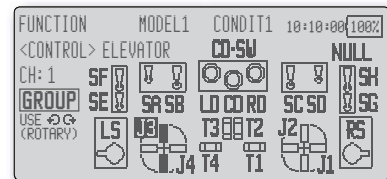

2. Use the cursor lever to move the cursor (blinking) to the icon of the control you want to change, and push the enter button.

*The same control can be assigned to multiple channels.

*The setting can be changed for each condition.

After the set mode is changed from group mode [GROUP] to single mode [SINGL] at the control selection screen, only that condition setting is changed by control change; setting of other conditions remains the same.

Trim setting

1. Use the cursor lever to move the cursor to the "TRIM" item of the channel you want to change and push the enter button.

*The trim setup screen is displayed.

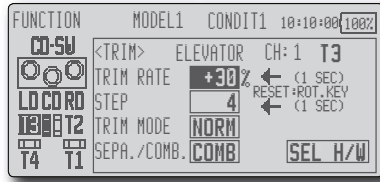

The following items can be set at the trim setup screen:

Trim selection

Use the cursor lever to move the cursor to [SEL H/W] and push the enter button.

*The trim setup screen is displayed.

Use the cursor lever to move the cursor (blinking) to the icon of the trim, lever, etc. you want to set and push the enter button.

*The setting can be changed for each condition.

After the set mode is changed from group mode [GROUP] to single mode [SINGL] at the trim setup screen, only setting of that condition is changed by control change; setting of other conditions remains the same.

Trim rate setting

Use the cursor lever to move the cursor to the [TRIM RATE] item and set the trim rate by turning the data input dial.

Initial value: +30%

Adjustment range : -150~+150%

(When the enter button is pushed for 1 second, the trim rate is reset to the initial value.)

Control step amount setting

Use the cursor lever to move the cursor to the [STEP] item and set the control step amount by turning the data input dial.

Initial value: 4

Adjustment range: 1~200

(When the enter button is pushed for 1 second, the control step amount is reset to the initial value.)

*When the value is made large, the change per step becomes larger.

Trim mode selection

Use the cursor lever to move the cursor to the [TRIM MODE] item and select the trim mode by turning the data input dial.

[NORM]: Normal mode. Normal trim (parallel shift trim) operation.

[ATL]: ATL operation mode. Maximum change near center by operation normally used with throttle trim. Reverse is also possible. ([NORM]/[REV] selection is possible

at the "ATL REV" item.)

[CTRM]: Maximum change near center by center trim operation.

Separate/combination mode selection

Use the cursor lever to move the cursor to the [SEPA./COMB.] item and change to blinking by turning the data input dial and select the mode by pushing the enter key.

[COMB]: Combination mode. The trim data are reflected at all the flight conditions.

[SEPA]: Separate mode. Trim adjustment for each flight condition.

Group/single mode setting

When the flight conditions are set, operation control and trim can be switched for each condition.

1. Turn the data input dial to the left at the control and trim selection screen. [GROUP] display changes to [SINGL] blinking. Push the enter button. (To return to the group mode [GROUP], turn the data input dial to the right. The [SINGL] display changes to [GROUP] blinking. Push the enter button.)

Group mode [GROUP]: The set contents are also linked to the conditions set in other group modes.

Single mode [SINGL]: Only the condition currently selected can be changed.

[Example of use]

Use when you want to switch butterfly and throttle stick in the glider mode, etc.

The Sub-Trim function is used to set the servo neutral position, and may be used to make fine adjustments to the control surface after linkages and pushrods are hooked up. When you begin to set up a model, be sure that the digital trims are set to their center position.

- Select [SUB-TRIM] at the linkage menu and call the setup screen shown below by pushing the enter button.

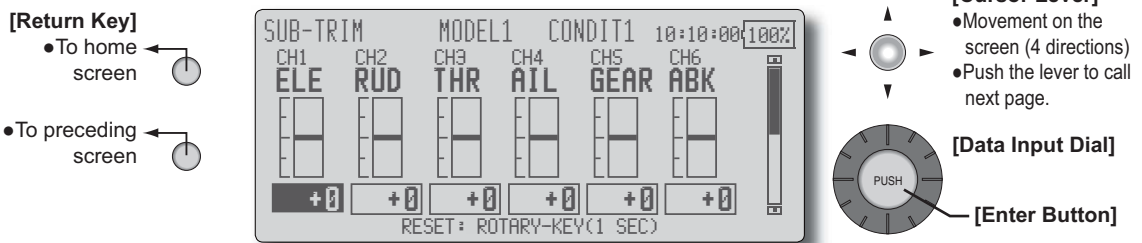

(The display screen is an example. The screen depends on the model type.)

Sub trim adjustment

1. Use the cursor lever to move the cursor to the channel you want to adjust.
2. Adjust by turning the data input dial.
Initial value: 0
Adjustment range: -240~+240 (steps)
(When the enter button is pushed for 1 second, sub trim is reset to the initial value.)
*Before sub trim adjustment, adjustment of the linkage so that control surfaces need not use sub trim as much as possible is very important.
3. Repeat this procedure for each channel.

SERVO-REVERSE

Use to reverse the throw direction.

Servo Reverse changes the direction of an individual servo's response to a control stick movement.

For CCPM helicopters, be sure to read the section on Swash AFR before reversing any servos. With CCPM helicopters, always complete your servo reversing prior to any other programming. If you use pre-built Airplane/Sailplane functions

that control multiple servos, it may be confusing to tell whether the servo needs to be reversed or a setting in the function needs to be reversed. See the instructions for each specialized function for further details. Always check servo direction prior to every flight as an additional precaution to confirm proper model memory, hook ups, and radio function.

- Select [SERVO REVERSE] at the linkage menu and call the setup screen shown below by pushing the enter button.

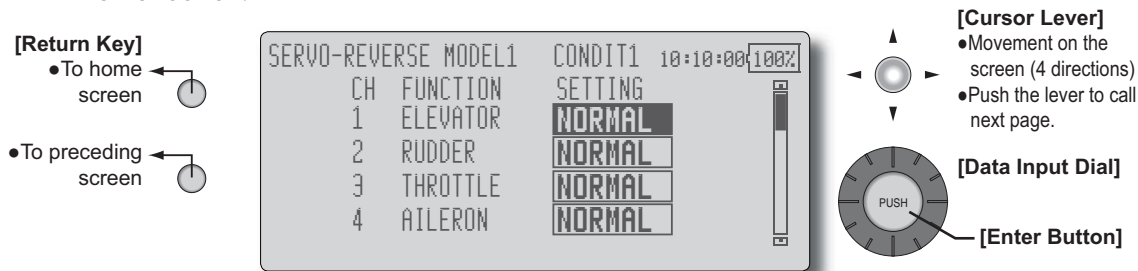

(The display screen is an example. The screen depends on the model type.)

Servo reversing procedure

*After linkage of a new model is complete, check whether or not each servo is connected to the correct channel.

*Next, determine whether you need to reverse any channels by moving each stick.

1. Use the cursor lever to move the cursor to the channel you want to reverse.
2. Turn the data input dial and change the display to [REVERSE] (or [NORMAL]).

*The display blinks.

3. When the enter button is pushed, servo operation is reversed. (Operate another key to stop reversal.)

*Repeat the operation above for each channel that must be reversed.

FAIL SAFE

Sets the servos operating position when transmitter signals can no longer be received or when the receiver battery voltage drops.

The Failsafe function may be used to set up positions that the servos move to in the case of radio interference.

This function only works with G3 or PCM receivers (FM receivers do not have failsafe capability).

When the receiver battery voltage drops, the servo can be moved to a preset position. (Battery fail safe function) A battery fail safe function reset switch can be set. (Initial setting: Throttle stick maximum slow side)

You may set either of two positions for each channel: Hold, where the servo maintains its last commanded position, or Failsafe, where each servo moves to a predetermined position. You may choose either mode for each channel.

The T12Z system also provides you with an advanced battery monitoring function that warns you when the receiver battery has only a little power remaining. In this case, each servo is moved to the defined failsafe position. The battery failsafe may be released by operating a predefined

control on the transmitter (default is throttle), **do not continue to fly, land as soon as possible.** Remember, if the predefined control suddenly moves to a position you did not command, land at once and check your receiver battery.

Defines servo position when signals are lost and when receiver battery voltage becomes low.

⚠ WARNING

❗ For safety, always set the fail safe functions.

- Especially set the throttle channel fail safe function so that the servo moves to the maximum slow side for airplanes and to the slow side from the hovering position for helicopters. Crashing of the model at full high when normal radio waves cannot be received due to interference, etc., is very dangerous.
- If fail safe is reset by throttle stick, it may be mistaken for an engine malfunction and will be reset at throttle slow and the model will continue to fly. If you have any doubts, immediately land.

- Select [FAIL SAFE] at the linkage menu and call the setup screen shown below by pushing the enter button.

[Return Key]

- To home screen
- To preceding screen

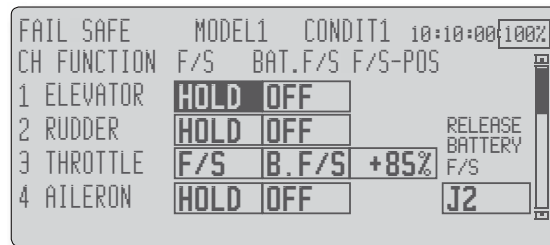

(The display screen is an example. The screen depends on the model type.)

[Cursor Lever]

- Movement on the screen (4 directions)
- Push the lever to call next page.

[Data Input Dial]

[Enter Button]

Fail safe setting procedure

1. Use the cursor lever and move the cursor to the "F/S" item of the channel you want to set.
2. Display [F/S] by turning the data input dial to the left.

*The display blinks.

3. Push the enter button. (Operate another key to stop setting.)

*The channel switches to the F/S mode.

4. Move the cursor to the "F/S-POS" item by moving the cursor lever to the right.

Hold the corresponding stick, knob, slider, etc. in the position you want the servo to move to when the fail safe function is activated and push the enter button.

*The set position is displayed in percentage.

*When you want to return that channel to the hold mode, use the cursor lever to move the cursor to the "F/S" item and display [HOLD] by turning the data input dial to the right and then change the mode by pushing the enter button.

Battery fail safe setting procedure

Battery fail safe can be set for each channel by the same method as the fail safe setting procedure. Select and set the "BAT.F/S" item.

[B.F/S]: Battery fail safe function ON

[OFF]: Battery fail safe function OFF

Battery fail safe release switch setting

This function temporarily releases the battery fail safe function for the fuselage to recover after the battery fail safe function was activated by a drop in the receiver battery voltage. This setting selects the switch which releases the battery fail safe function.

1. Use the cursor lever to move the cursor to the [RELEASE BATTERY F/S] item.

2. Push the enter button.

*The switch selection screen is called.

*For a detailed description of the switch selection and ON/OFF direction setting method, see [Switch Setting Method] at the back of this manual.

END POINT (ATV)

Sets the travel, limit point, and speed of each servo.

The End Point function adjusts the left and right servo throws, generates differential throws, and will correct improper linkage settings.

The Travel rate can be varied from 30% to 140% in each direction on channels 1 to 12. Also, the Limit point where servo throw stops may be varied from 0% to 155%.

NOTE: The Servo Speed setting is used to set the servo delay for each channel, from channel 1 to channel 12. The system uses the programmed speed (delay) to slow down servo position changes. The Servo Speed setting can be varied from 0 to 27 in each channel.

- Select [END POINT(ATV)] at the linkage menu and call the setup screen shown below by pushing the enter button.

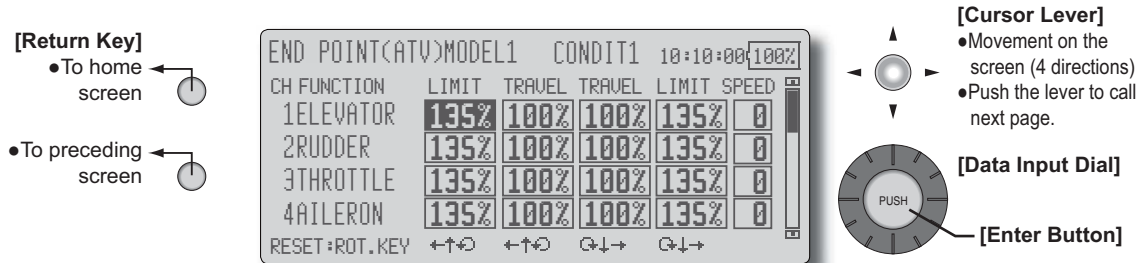

(The display screen is an example. The screen depends on the model type.)

Servo travel adjustment

1. Use the cursor lever to move the cursor to the "TRAVEL" item of the channel you want to adjust.
2. Turn the data input dial to adjust the rate.
Initial value: 100%
Adjustment range: 30%~140%
(When the enter button is pushed for 1 second, the rate is reset to the initial value.)
3. Repeat this procedure for each rate.

Limit point adjustment

1. Use the cursor lever to move the cursor to the "LIMIT" item of the channel you want to adjust.
2. Turn the data input dial to adjust the limit point.
Initial value: 135%
Adjustment range: 0%~155%
(When the enter button is pushed for 1 second, the limit point is reset to the initial value.)
3. Repeat this procedure for each limit point.

Servo speed setting

1. Use the cursor lever to move the cursor to the "SPEED" item of the channel you want to adjust.
2. Turn the data input dial to adjust the servo speed.
Initial value: 0
Adjustment range: 0~27 (steps)
(When the enter button is pushed for 1 second, the servo speed is reset to the initial value.)
3. Repeat this procedure for each channel.

THROTTLE CUT

Stops the engine safely and easily. (airplane and helicopter only)

Throttle cut provides an easy way to stop the engine, by flipping a switch with the throttle stick at idle. The action is not functional at high throttle to avoid accidental dead sticks. The switch's location and direction must be chosen, as it defaults to NULL.

- Select [THROTTLE CUT] at the linkage menu and call the setup screen shown below by pushing the enter button.

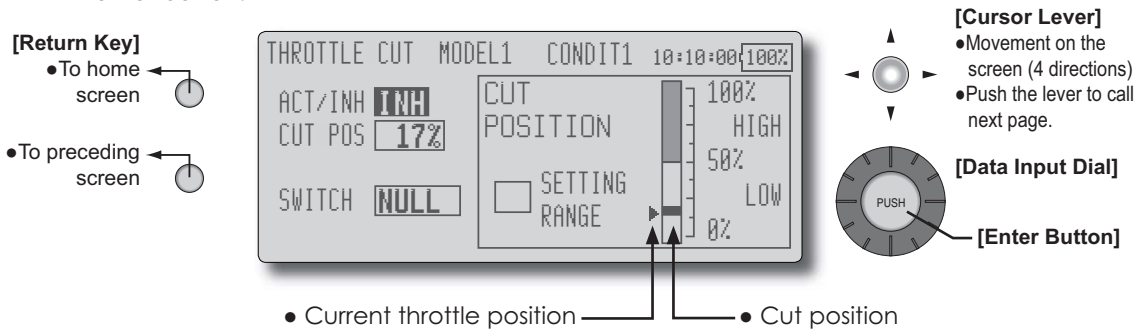

Throttle cut setting procedure

*Perform the following settings before using the cursor lever to move the cursor to the item to be set.

1. Activate the function:

Move the cursor to the [ACT/INH] item and turn the data input dial to the left until the blinking changes from "INH" to "ON" (or "OFF") and then push the enter button.

2. Switch setting:

Move the cursor to the [SWITCH] item and call the switch setup screen by pressing the enter button and select the switch and ON direction.

(For a detailed description of the setting method, see [Switch Setting Method] at the back of this manual.)

3. Throttle cut position setting:

Move the cursor to the [CUT Pos] item and adjust the servo operation position at throttle cut operation by turning the data input dial to the left or right.

Initial value: 17%

Adjustment range: 0%~50%

(When the enter button is pressed, the servo operation position is reset to the initial value.)

*With the selected cut switch ON and the throttle stick at idle; adjust the rate until the engine consistently cuts off.

However, be sure that the throttle linkage does is not pulled too tight and unreasonable force is not applied to the servo.

The Idle Down function lowers the engines idle by flipping a switch with the throttle stick at idle. The action is not functional at high throttle to avoid accidental dead sticks. The switch's location and direction must be chosen, as it defaults to NULL.

- Select [IDLE DOWN] at the linkage menu and call the setup screen shown below by pushing the enter button.

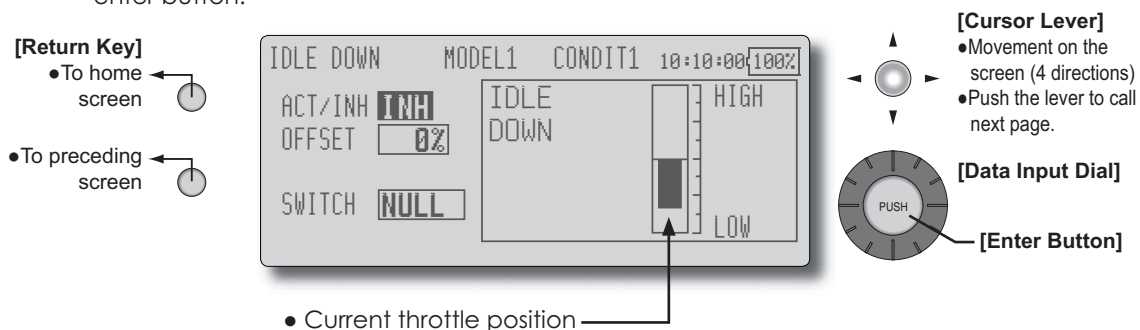

Idle down setting procedure

*Perform the following settings after using the cursor lever to move the cursor to the item you want to set.

1. Activate the function:

Move the cursor to the [ACT/INH] item and switch the blinking from "INH" to "ON" (or "OFF") by turning the data input dial to the left and then push the enter button.

2. Switch setting:

Move the cursor to the [SWITCH] item, call the switch setup screen by pushing the enter button, and select the switch and ON direction.

(For a detailed description of the setting method, see [Switch Setting Method] at the back of this manual.)

3. Offset rate setting:

Move the cursor to the [OFFSET] item and adjust the servo offset rate at idle down operation by turning the data input dial to the left or right.

Initial value: 0%

Adjustment range: 0%~100%

(When the enter button is pushed for 1 second, the offset rate is reset to the initial value.)

*Maximum offset amount is near maximum slow.

Neutral Point

At your linkages, if the servo horn deviates from a perpendicular position at neutral, the linkage compensation functions in this menu may not compensate effectively. To correct this use the Neutral Point function. This will move the neutral point of the servos to the actual perpendicular position. However, this adjustment changes only the datum point of the compensation functions in this menu, and does not affect the neutral position of other functions.

Swash AFR

Swash AFR function reduces/increases/reverses the rate (travel) of the aileron, elevator and collective pitch functions, by adjusting or reversing the motion of all servos involved in that function, only when using that function.

Mixing Rate

This compensation mixing is used to correct the tendency of the swash-plate for each control near

the hovering point. The following compensation mixing is possible; PIT to AIL, PIT to ELE, AIL to PIT, ELE to AIL, and ELE to PIT. It adjusts the swash-plate to operate correctly for each control near the hovering point using the corresponding compensation mixing.

Linkage Compensation

This compensation mixing is used to correct the tendency of the swash-plate for pitch control at low pitch and high pitch. It adjusts the swash-plate to move horizontally for collective pitch control using the corresponding compensations.

Speed Compensation

This function is used to cancel the reaction when the swash-plate moves in the vertical direction by sudden elevator changes. The delay amount of elevator can be programmed.

- Select [SWASH] at the linkage menu and call the setup screen shown below by pushing the enter button.

[Return Key]

- To home screen
- To preceding screen

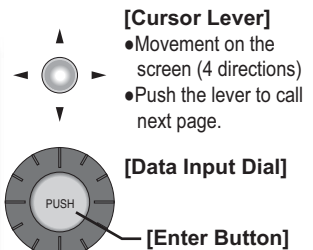
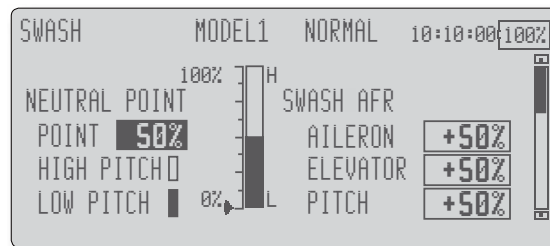

*Before making the following settings, use the cursor lever to move the cursor to the item you want to set.

Neutral point setting procedure

The neutral point becomes the correction standard point.

*Adjusting the servo horn so that the neutral point is near the 50% position makes the mixing amount small.

1. Neutral point setting

Move the cursor to the [POINT] item and hold the pitch operation so that the servo horn is at a right angle to the linkage rod and push the enter button and read the neutral position.

*The neutral point can also be displayed by bar graph.

After reading the neutral point, use the other correction functions to make further adjustments.

Swash AFR setting procedure

The swash AFR function makes adjustments so that the servos travel the specified amount by [AILERON], [ELEVATOR], and [PITCH] operation.

1. Adjust the AFR rate by turning the data input dial to the left or right.

Initial value: 50%

Adjustment range: -100%~+100%

(When the enter button is pushed for 1 second, the AFR rate is reset to the initial value.)

Mixing rate setting procedure

The HR-3 is taken as an example to describe mixing rate setting. Mixing applied in other swash modes is different, but the setting procedure is the same.

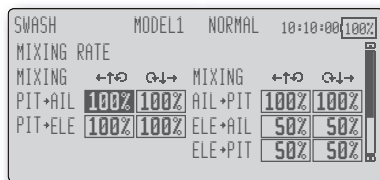

1. Set the throttle stick to the preset neutral point. Adjust the length of the linkage rod so that the swash plate is horizontal at this position.

*The sub trim function can be used to make small adjustments.
*Adjust so that the pitch curve is a straight line and pitch operation is maximum.

2. Adjustment at aileron operation [AIL to PIT]

Adjust the AIL to PIT rate so there is no interference in the elevator or pitch direction when the aileron stick is moved to the left and right.

*Adjust by turning the data input dial to the left or right.
*The left and right sides can be adjusted individually.

3. Adjustment at elevator operation [ELE to AIL]/[ELE to PIT]

Adjust the ELE to AIL and ELE to PIT rates so there is no interference in the aileron or pitch direction when the elevator stick is moved up and down.

*Adjust by turning the data input dial to the left and right.
*The up and down sides can be adjusted individually.

4. Adjustment at pitch operation [PIT to AIL]/[PIT to ELE]

Adjust the PIT to AIL and PIT to ELE rates so that the swash plate moves to the horizontal position when the throttle stick was moved to maximum slow and full high.

*Adjust by turning the data input dial to the left and right.
*The slow and high sides can be adjusted individually.

Linkage compensation setting procedure

*Perform linkage compensation setting after mixing rate setting.

*Linkage compensation compensates for interference by aileron operation with the elevator or elevator operation with the aileron at collective pitch (HR3, etc.) control for Low pitch and Hi pitch.

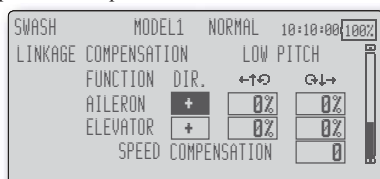

1. Compensation at aileron operation [AILERON]

Set the throttle to the maximum slow position. Move the aileron stick to the left and right and adjust the aileron compensation amount so that interference in the elevator or pitch direction at that time is minimum.

*Adjust the data input dial to the left and right.

*The left and right sides can be adjusted individually.

*When the interference increases when the compensation amount was increased, make adjustments with the compensation direction [DIR] as "-".

2. Compensation at elevator operation [ELEVATOR]

Adjust the elevator compensation amount so that the aileron or pitch direction interference when the elevator stick was moved up and down is minimum.

3. Regarding steps 1 and 2 above, perform aileron and elevator compensation similarly at the full high side of the throttle stick also.

Speed compensation setting procedure

1. Set the throttle stick to the neutral point position. Quickly move the elevator stick and adjust the speed compensation amount [SPEED COMPENSATION] for minimum interference in the pitch direction.

*Adjust by turning the data input dial to the left and right.

The Timer function may be set for any desired time, i.e. engine run time, specified times for competitions, etc. Two independent timers are provided for your use. The timers are stored independently with each model, meaning that when you switch between model setups, the timer associated with the new model is brought up automatically.

The timers may be set to start and stop from the motion of any switch or stick. You may set the ON and OFF directions freely. Each timer has a capacity of up to 59 minutes 59 seconds.

- Select [TIMER] at the linkage menu and call the setup screen shown below by pushing the enter button.

[Return Key]

- To home screen

- To preceding screen

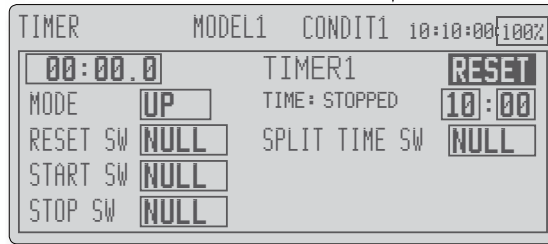
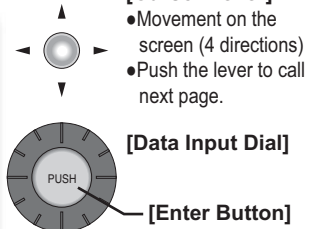
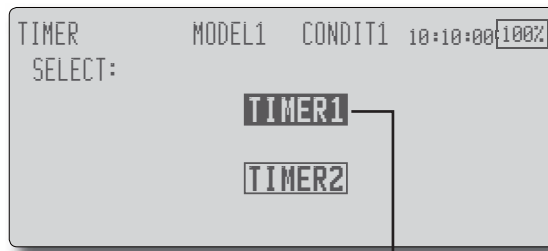

Each timer may be set for count-down or count up operation with a target time. Also Split Time may be counted.

If a target time is set and the timer reaches the set time, a buzzer sound for each count is generated.

Countdown timers sound one short beep during the last twenty seconds and two short beeps during the last ten seconds before reaching the target, then a long tone at the target time, and continue counting with displaying a minus (-) sign. Count-up timers also beep the last twenty and ten seconds, beep the target time, and keep counting upwards until shut down.

Timer setting

*Perform the following settings after using the cursor lever to move the cursor to the item you want to set.

1. Up timer/down timer setting

Move the cursor to the [MODE] item and select the mode by moving the data input dial to the left or right.

[UP]: Up timer

[DOWN]: Down timer

2. Timer time setting

Move the cursor to the [10]:[100] item and set the time by turning the data input dial to the left or right.

[00]:[00]:[min]:[sec]

3. Switch setting

Move the cursor to the item of the switch you want to set, call the switch setup screen by pushing the enter button, and select the switch and ON direction.

[For a detailed description of the setting method, see [Switch Setting Method] at the back of this manual.]

[RESET SW]: Reset switch

[START SW]: Start switch

[STOP SW]: Stop switch

[SPLIT TIME SW]: Split time switch

Timer operation

- Timer 1 and Timer 2 are started/stopped by pre-selected start/stop switch.
- When measuring the lap time, operate the pre-selected split time switch. Each time this switch is operated, the lap time is stored. To display the lap times, move the cursor to [SPLIT LIST] displayed on the timer screen and push the enter button.

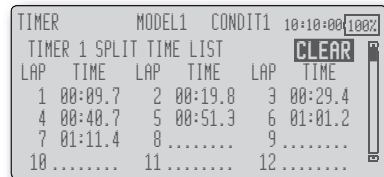

- To reset a timer, operate the pre-selected reset switch, or move the cursor to the [RESET] display on the timer screen and push the enter button.

DIAL MONITOR

LDisplays the position of the dials, slider levers, and digital trim.

Digital Trim Position display (T1-T4, CD)

The Dial Monitor displays the current position and the operation step amount of each Digital Trim.

VR and slide lever position display (LS, LD, RD, RS)

Displays the current position (▼) and last operating position (△) of the VRs and slider levers.

- Select [DIAL MONITOR] at the linkage menu and call the setup screen shown below by pushing the enter button.

- [Return Key]**
- To home screen
 - To preceding screen

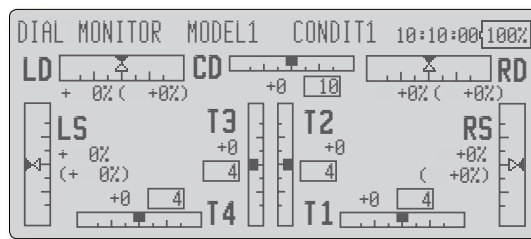

- [Cursor Lever]**
- Movement on the screen (4 directions)
 - Push the lever to call next page.
- [Data Input Dial]**
- [Enter Button]**

Calling knob and slide lever position (LS, LD, RD, RS)

Since the knobs and slide levers are the so-called "analog" type, their operation position cannot be held. The last operating position can be called by the operation below.

1. Operate the knob or slide lever and set the current position (▼) to the last operating position (△). The last operating position is called.

This function is designed to allow you to reset selected portions or all of the settings saved in the active model memory. You may individually choose to reset the following sets of data;

T1~T4, CD:

Reset the digital trim setting.

*All the conditions, or the condition currently being displayed (the entire group for group setting), can be selected.

Model menu setting:

Resets all the functions in the Model Menu except Condition Select.

All model setting:

Resets all Linkage and Model Menu functions except for Frequency, Model Select, and Model Type.

- Select [DATA RESET] at the linkage menu and call the setup screen shown below by pushing the enter button.

[Return Key]

- To home screen
- To preceding screen

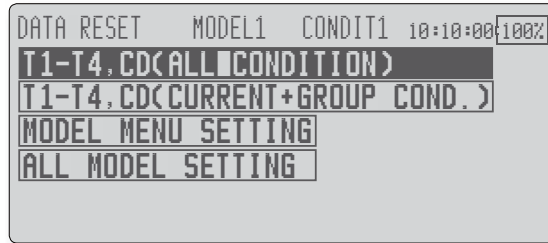

[Cursor Lever]

- Movement on the screen (4 directions)
- Push the lever to call next page.

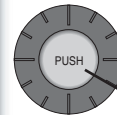

[Data Input Dial]

[Enter Button]

Data resetting method

*Perform the following settings after using the cursor lever to move the cursor to the item you want to set.

1. Move the cursor to the item you want to reset and push the enter button.

*A confirmation message appears.

2. Execute reset by pushing the enter button again. (Operate another key to stop resetting.)

[T1-T4, CD (ALL CONDITION)]: Resets only the T1-T4, CD (all conditions)

[T1-T4, CD(CURRNT+GROUP COND.)]: Resets only the data of T1-T4, CD (conditions in use and same group)

[MODEL MENU SETTING]: Resets all the functions in the model menu, except the condition selection functions.

[ALL MODEL SETTING]: Resets all the functions in the linkage menu and model menu except the frequency, model select, and model type functions.

This function may be used to fix the maximum speed of the engine so that you may adjust flight conditions when the engine is running. An alarm indicates that the function is operating. It will prevent the engine from racing dangerously when adjusting the Idle-Up settings.

While this function is active, the throttle servo position is fixed at the point where you operate when the function is activated. You must deactivate this function when you are through making adjustments.

The system will not allow you to activate/deactivate this function in either of the following states:

- When any of the flight condition switches are on.
- When the throttle stick is higher than the 1/3 point.

To activate/deactivate Condition hold:

(Home screen)

1. Move the cursor to [CND HOLD].
2. Set the throttle stick lower than the 1/3 point.
3. Push the enter button to activate the condition hold function.

*When this function is active, "IS ACTIVE" appears at the bottom of the [CND HOLD] display at the left bottom of the screen.

(LINKAGE menu/MODEL menu)

1. Move the cursor to [COND. HOLD].
2. Set the throttle stick lower than the 1/3 point.
3. Push the enter button to activate the condition hold function.

*Operation is displayed at the bottom of the menu.

Function ON: "CND HOLD: ACT(ON)" is displayed.

Function OFF: "CND HOLD: INH(OFF)" is displayed.

MODEL MENU (COMMON FUNCTIONS)

This section describes the AFR, program mixing, and other functions common to all model types.

Before setting the model data, use the Model Type function of the Linkage Menu to select the model type matched to the fuselage. When another model type is selected thereafter, the AFR, program mixing, and other setting data are reset.

The functions in the Model Menu can be set for each flight condition. When you want to use the system by switching the settings for each condition by switch, stick position, etc., use the Condition

Select function to add flight conditions. (Up to 8 conditions can be used)

Note: The T12Z is designed so that the airplane and glider (including EP glider) model types are compatible with aircraft of similar type wings.

This section outlines the relationship between the functions common to airplanes and gliders, except some dedicated functions, and model type.

The setting items depend on the number of servos and other differences according to the wing type used, but reread them. The setup screens in the instruction manual are typical examples.

- Select the model menu icon at the home screen and call the model menu shown below by pushing the enter button.
- Use the cursor lever to select the function you want to set and call the setup screen by pushing the enter button..

(Model Menu screen example)

*The Model Menu screen depends on the model type. This screen is for model type 4AIL+4FLP.

[Return Key]

- To home screen
- To preceding screen

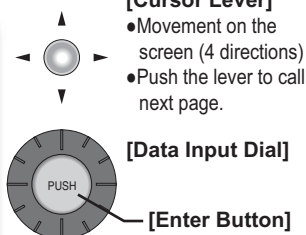
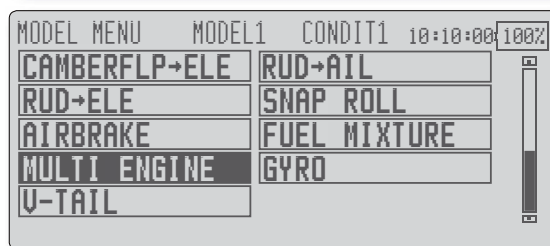
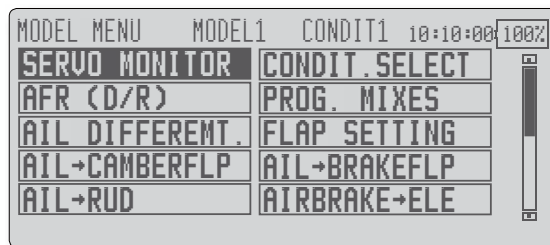

Model Menu functions (Common) list

•SERVO MONITOR

Servo test and servo position display (For a description of its functions, see the Linkage Menu section.)

•CONDIT.SELECT

Flight conditions addition, deletion, copy, condition renaming, and condition delay can be set.

•AFR (D/R)

Sets the rudder angle and curve of all the operation functions. A D/R curve which can be switched with a switch, etc. can also be added.

•PROG. MIX

Program mixing which can be freely customized. Up to 10 mixes can be used for each condition.

•FUEL MIXTURE

Mixing used in needle adjustment of engines which use a fuel mixture control carburetor. [Airplane, helicopter]

CONDIT. SELECT

Flight condition's addition, deletion, copy, condition renaming, and condition delay can be set. [All model types]

The functions in the Model Menu can be used by switching the settings of up to 8 flight conditions by using the Condition Select function to add flight conditions. Add conditions, as required.

When you do not want to use the Condition Select function, this setting is unnecessary. In this case, use the flight conditions (CONDIT1 or NORMAL) assigned at initial setting.

- Since switching by stick and lever position, in addition to ordinary toggle switch, is possible as the flight condition selector switch, this function can be linked with other operations.
- A Condition Delay function can be set. Unnecessary fuselage motion generated

when there are sudden changes in the servo positions and when there are variations in the operating time between channels during condition switching can be suppressed. The delay can be set for each channel.

When setting the delay function at the switching destination condition, the related function changes after a delay corresponding to the set amount.

- When multiple conditions were set, their operation priority can be freely changed.
- The condition name can be changed. The selected condition name is displayed on the screen. When a condition has been added, give it a name which can be easily confirmed.

- Select [CONDIT. SELECT] at the model menu and call the setup screen shown below by pushing the enter button.

(Currently selected condition name)

[Return Key]
• To home screen
• To preceding screen

[Cursor Lever]
• Movement on the screen (4 directions)
• Push the lever to call next page.

[Data Input Dial]

[Enter Button]

(Conditions List)

*Perform the settings below after using the cursor lever to move the cursor to the item you want to set.

Condition addition

1. Move the cursor to [ADD] and push the enter button.
*Only the No. of the conditions which can be added is displayed.
2. Add the condition by pushing the enter button again.

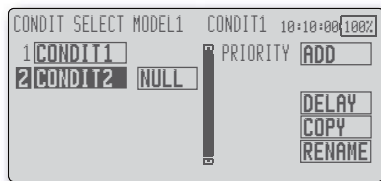

3. Move the cursor to [NULL], call the switch setup screen by pushing the enter button, and select the switch and ON direction to be used in condition switching.

(For a detailed description of the setting method, see [Switch Setting Method] at the back of this manual.)

*The data (except the condition name) of the condition currently being used is copied to the added condition.

Condition deletion

1. Use the cursor lever to move the cursor to the condition you want to delete in the conditions list.
*The number before the condition name starts to blink to show that it is to be deleted.
2. After once operating the cursor lever to the left or right, move the cursor to [REMOVE] and push the enter button.
*A confirmation message is displayed.
*Note that if initially operated up and down, the objective condition changes.
3. When the enter button is pushed again, the condition is deleted. (Operate another key to stop deletion.)

Condition name change

1. Use the cursor lever to move the cursor to the condition you want to change in the conditions list.
2. After once operating the cursor lever to the left or right, move the cursor to [RENAME] and push the enter key.
*The condition name setup screen appears.

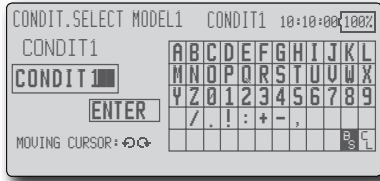

- Use the data input dial to select the digit you want to change of the condition name, select the candidate character with the cursor lever and push the enter button. Change the other digits similarly.

*A name of up to 8 characters can be entered as the condition name. (Space is also counted as one character.)

*[BS] erases the cursor position character and [CL] erases the cursor position character and all the following characters.

- At the end of input, select [ENTER] with the cursor lever and push the enter button.

*When you want to stop input and return to the original state, select [CANCEL] and push the enter button.

- Return to the original screen by pushing the return key.

Condition copy

- Use the cursor lever to move to [COPY].

- Push the enter button.

*The copy screen appears.

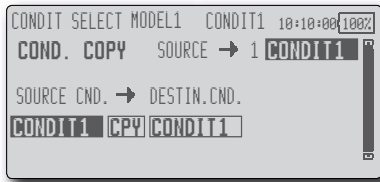

- Use the cursor lever to move the cursor to the "SOURCE CND." (copy source) item.

*The models already saved are displayed at the right side of the screen.

- After using the cursor lever to move the cursor to the copy source condition, push the enter key.

*The copy source condition is displayed at the "SOURCE CND." position.

- Use the cursor lever to move the cursor to "DESTIN.CND." (copy destination).

*The models already saved are displayed at the right side of the screen.

- After using the cursor lever to move the cursor to the copy destination condition, push the enter button.

*The copy destination conditions are displayed at the "DESTIN.CND." position.

- Use the cursor lever to move the cursor to [CPY] and push the enter button.

*A confirmation message is displayed.

- When the enter button is pushed again, copy is executed (Operate another key to stop copying.)

Priority change

- Use the cursor lever to move the cursor to the condition whose priority you want to change in the condition list.
- After once operating the cursor lever to the left or right, move the cursor to [UP] or [DOWN] of [PRIORITY] and push the enter button. (The last condition becomes the highest priority.)

*The initial setting condition cannot be shifted. The priority is the lowest.

Condition delay setting

- Use the cursor lever to move the cursor to the condition you want to change in the condition list.

- After once operating the cursor lever to the left or right, move the cursor to [DELAY] and push the enter button.

*The condition delay setup screen appears.

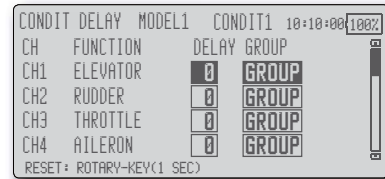

- Use the cursor lever to move the cursor to the "DELAY" item of the channel you want to set and adjust the delay amount with the data input dial.

Initial value: 0

Adjustment range: 0~27 (maximum delay)

- The setting mode (group [GROUP]/single [SINGL] mode) can be switched.

(For more information, see the description at the back of this manual.)

AFR (D/R)

The rudder angle and curve of each operation function can be set. A D/R curve which can be switched by switch, etc. can also be added. [All model types]

AFR function is used to adjust the throw and operation curve of the stick, lever, and switch functions (CH1 to CH12, and V1 to V4) for each flight condition. This is normally used after End Point (ATV) has defined the maximum throw directions (End Point acts on ALL flight condition settings). When mixing is applied from one channel to another channel, both channels can be adjusted at the same time by adjusting the operation rate through the AFR function.

- Operation curve adjustment: Six types of curves (linear, EXP1, EXP2, VTR, line and spline) can be selected. A maximum 17 points curve can be used for the line and spline curve types. (Initial setting: 9 points) The number of points can also be increased and decreased and curves from complex curves to simple curves can be used.
- Operation speed adjustment: The operation speed of each function when the function is operated (including at flight condition switching) can be adjusted. The function operates smoothly at a constant speed corresponding to the set speed.

- Select [AFR(D/R)] at the model menu and call the setup screen shown below by pushing the enter button.

(Currently selected condition name)

[Return Key]
 • To home screen
 • To preceding screen

[AFR/D/R]: Displays the currently selected rate (AFR, D/R1-6).

[Cursor Lever]
 • Movement on the screen (4 directions)
 • Push the lever to call next page.

[Data Input Dial]
 [Enter Button]

• Operation curve setting
 (For a description of the setting method, see the description at the back of this manual.)

• Function selection

[GRP/SNG]: Group/single mode setting display

• Group/single mode switch (GROUP/SINGLE)
 (For more information, see the description at the back of this manual.)

• D/R function setting

• Servo speed setting
 (For a description of the setting method, see the description at the back of this manual.)

• Function selection

(Number of D/R curves set at the currently selected condition)

Function selection method

1. Use the cursor lever to move the cursor to [FUNCTION].
2. Select the desired function by turning the data input dial to the left or right, push the enter button.

*The setting mode (group [GROUP]/single [SNGL] mode) can be switched (For more information, see the description at the back of this manual.)

Dual rate setting

Up to 6 dual rates can be set for each condition.

*D/R (dual rate) is set for each condition and is not reflected at other conditions.

*D/R (dual rate) at the top of the D/R list has priority.

Setting example

Use a switch to turn low rates on and off. When D/R is used by using the condition with the same switch, another rate can be set.

[Selection method]

1. At the AFR(D/R) setup screen of the function (aileron, elevator, etc.) whose rate you want to change, move the cursor to the [AFR/DR] item and display the D/R list below by pushing the enter button.

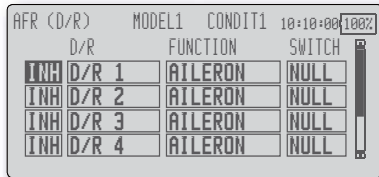

2. Move the cursor to the [INH] display of an unused D/R and turn it off by turning the data input dial to the left and activate the D/R function by pushing the enter button.
3. When the cursor is moved to the [FUNCTION] item and the data input dial is turned to the left and the enter button is pressed, D/R is assigned to the currently set function.
4. Move the cursor to the [SWITCH] item and call the switch setup screen by pushing the enter button and select the switch and ON direction.

(For a detailed description of the setting method, see [Switch Setting Method] at the end of this manual.)

[Name change]

1. Use the cursor lever to move the cursor to the D/R name you want to change and push the enter button.

*The setup screen appears.

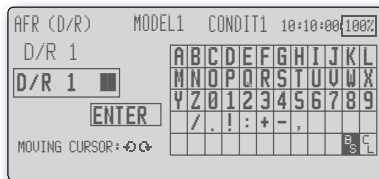

3. Use the data input dial to select the digit you want to change of the D/R name, select the character with the cursor lever, and push the enter button. Change the other digits similarly.

*A name of up to 8 digits can be entered. (Space is also counted as one character.)

*[BS] erases the cursor position character and [CL] erases the cursor position character and all the following characters.

4. At the end of input, select [ENTER] with the cursor lever and push the enter button.

*When you want to stop input and return to the original state, select [CANCEL] and push the enter button.

5. Return to the original screen by pressing the return key.

PROG. MIXES

Program mixing which can be freely customized. Up to 10 mixings can be used for each condition. [All model types]

Programmable mixing may be used to correct undesired tendencies of the aircraft, and it may also be used for unusual control configurations. Mixing means that the motion of a command channel, called the "master," is added to the motion of the mixed channel, called "slave."

You may choose to have the Master's trim added to the Slave channel response ("Trim" setting). The mixing curve can be changed so that the undesired tendencies can be corrected effectively by setting the LINEAR1/LINEAR2/EXP1/EXP2/VTR/LINE/SPLINE modes. The Delay function can be programmed for each rate. The Delay is used to change the rate smoothly when switching mixes. You may define Mixing ON/OFF switch, control or you may choose to have mixing

remaining on all the time.

Offset-type mixing applies a fixed offset or preset to the programmed channel servo operation and may control up to four circuits simultaneously. The Programmable mixing includes a powerful link function, which allows Programmable mixing to be linked with the special mixing functions, or with other programmable mixing functions. The link function can be set up for Master and Slave channel individually.

The slave channel AFR mode (STK-STK mode) may be selected, where the slave channel AFR and D/R settings are observed when Link function is set. The knob for fine tuning can be set up for every mixing circuit. (Fine tune function)

- Select [PROG. MIXES] at the model menu and call the setup screen shown below by pushing the enter button.

- [Return Key]**
- To home screen
 - To preceding screen

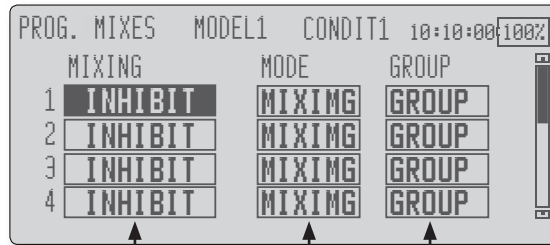

- [Cursor Lever]**
- Movement on the screen (4 directions)
 - Push the lever to call next page.
- [Data Input Dial]**
- [Enter Button]**

Mix setup screen call

- Move the cursor to the mix No. whose function you want to activate and call the setup screen by pushing the enter button.
- *When the function is activated, the master and slave channel name or "OFFS.MIX" is displayed.

- Group/single mode switching (GROUP/SINGLE)
(For more information, see the description at the back of this manual.)

Mixing mode change

- Move the cursor to the mix No. whose mode you want to change, change the mode display (blinks) by turning the data input dial and change the mode by pushing the enter button.
- [MIXING]: Mixing from normal master CH to slave CH
[OFFSET]: Master CH not used

(Currently selected condition name)

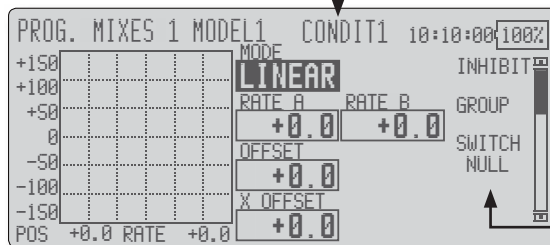

- Setting mode display

- Operation curve setting
(For a description of the setting method, see the description at the back of this manual.)

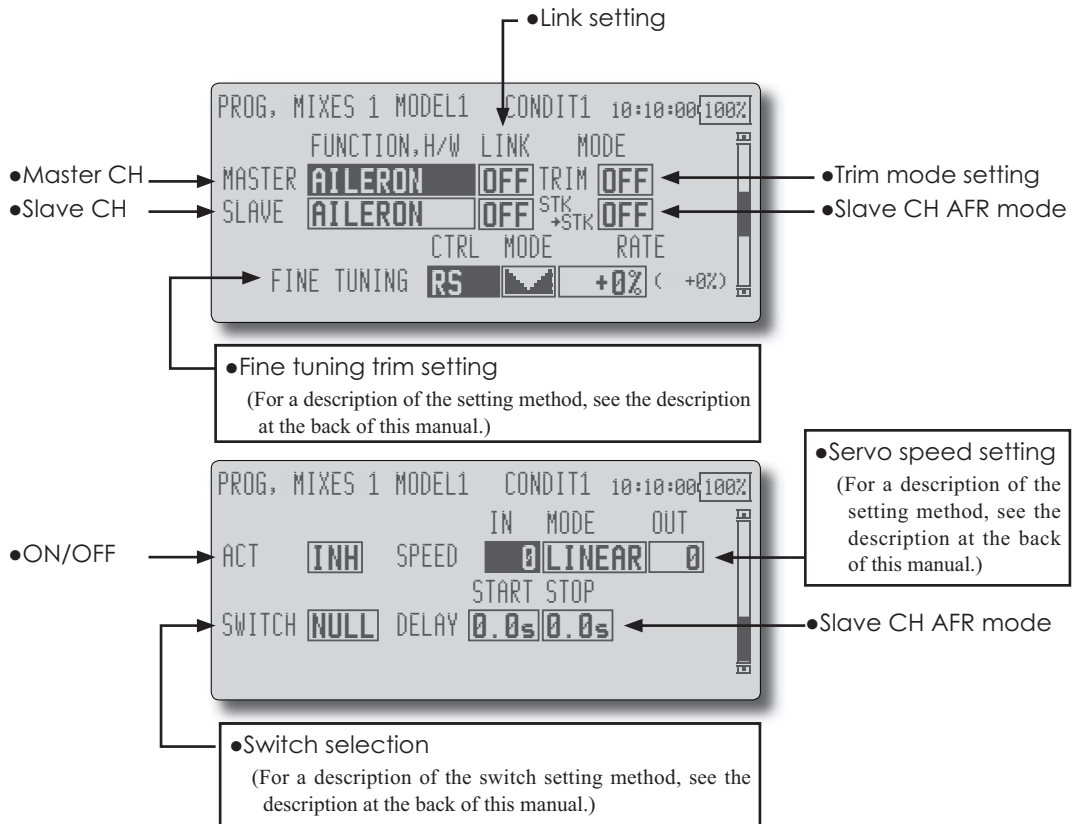

*Perform the settings below after using the cursor lever to move the cursor to the item you want to set.

●Group/single mode selection

1. When you want to activate functions for only selected conditions, move the cursor to the [GROUP] item.
2. Turn the data input dial to the left until [SINGLE] starts to blink and then push the enter button.

*The mode changes to the single mode [SINGLE].

*When using common settings at each conditions, remain in the [GROUP] mode.

●Activate the function.

1. Move the cursor to [INH].
2. Turn the data input dial to the left until [ACT] starts to blink and then push the enter button.

*The function is activated. (ON or OFF display)

*ON/OFF switch is not set even through the function is activated.

●ON/OFF switch setting

Move the cursor to the [SWITCH] item, call the switch setup screen by pushing the enter button, and select the switch and ON direction.

(For a description of the setting method, see [Switch Setting Method] at the back of this manual.)

*Always on when [NULL].

●Master channel setting (except offset type mixing)

1. Set the master channel by moving the cursor to the [FUNCTION.H/W] item of [MASTER] and select the function by turning the data input dial and push the enter button.
2. When you want to link this mixing with other mixes, move the cursor to the [LINK] item and set the link mode to [+] or [-] by turning the data input dial.

*Check the direction by actual operation.

*Master channel control can be set to simple operating amount of sticks and VR which do not include ATV, AFR, D/R, and mixing setting. In this case, the switch setup screen is displayed by pushing the enter button with "H/W" selected by function selection. Select master channel side control.

●Slave channel setting

1. Set the slave channel by moving the cursor to the [FUNCTION.H/W] item of [SLAVE] and select the function by turning the data input dial and push the enter button.
2. When you want to link this mix with other mixes, move the cursor to the [LINK] item and set the link mode to [+] or [-] by turning the data input dial.

*Check the direction by actual operation.

●Trim mode ON/OFF setting

1. When changing the trim mode, move the cursor to the [TRIM] item, select ON/OFF by turning the data input dial and set the selection by pushing the enter button.

*When mixing includes master side trim, select [ON] and when mixing does not include master trim, select [OFF].

*Effective when a function is set at the master channel.

●Slave channel AFR mode setting (STK-STK)

1. Move the cursor to the [STK-STK] item, select the mode by turning the data input dial, and change the mode by pushing the enter button.

*When link is set at the slave side, and you want to add AFR (D/R) to the mixing rate, select [ON].

*This is effective when the linkage is the same, but the travels are substantially different.

●Mixing curve setting

(For a description of the curve setting method, see the description at the back of this manual.)

●Fine tuning trim setting

Operation control [CTRL], operation mode [MODE], and rate [RATE] adjustment is possible by [FINE TUNING] item.

(For a description of the fine tuning trim setting method, see the description at the back of this manual.)

●Servo speed setting (including operation start point setting)

Adjustment is possible with the [SPEED] item.

(For a description of the servo speed setting method, see the description at the back of this manual. [Servo Speed Setting (2)]).

*Offset mixing changes the speed. Use the [Speed] In and Out buttons to readjust the speed.

*The mixing switch can set a delay [DELAY] with a different rate at starting and stopping.

*This function is inactive when a mixing switch is not set.

FUEL MIXTURE

Dedicated mixing used in needle adjustment of engines which use a fuel mixture control carburetor. [Airplane, helicopter]

This function is dedicated mixing used in needle adjustment of an engine that uses a fuel mixture control carburetor.

*The needle channel is not assigned as a default.

- Select [FUEL MIXTURE] at the model menu and call the setup screen shown below by pushing the enter button.

(Currently selected condition name)

[Return Key]

- To home screen
- To preceding screen

[Cursor Lever]

- Movement on the screen (4 directions)
- Push the lever to call next page.

[Data Input Dial]

[Enter Button]

• Operation curve setting
(For a description of the setting method, see the description at the back of this manual.)

• Mode setting

• Group/single mode switching (GROUP/SINGLE)
(For more information, see the description at the back of this manual.)

• Acceleration setting

• Needle trim setting

• Engine cut setting

Setting method

- *Before using this function, assign the [FUEL-MIX] function to a vacant channel by linkage menu [FUNCTION] function.
- *Perform the following settings after using the cursor lever to move the cursor to the item you want to set.
- When using this function, move the cursor to the [ACT/INH] item and turn the data input dial to the left and push the enter button. (ON is displayed.)
- The needle curve can be set. When [MIX] is selected at the [MIX/UNMIX] item, the throttle curve setting data becomes the mixing master side data. When [UNMIX] is selected, the throttle stick position becomes the mixing master side data.
- Needle trim ([HALF]) and needle high trim ([HIGH]) can be set.

The needle trim type (CTRM/NORM) can be selected and its operating range can be set.

[CTRM] mode: Maximum change near center by center trim operation. When [RANGE] is made small, trim is active only near the center.

[NORM] mode: Normal trim (parallel shift trim). When [RANGE] is made small, trim is active only near the center.

Needle high trim works as high trim based on the center. (Works like ATL trim.)

- An acceleration function can be set. This function is used when there are symptoms of the mixture being too lean or too rich, which would be generated by sudden operation of the throttle stick.

(For a description of the acceleration function setting method, see the description at the back of this manual.)

- A needle engine cut function can be set. (Hold position) Operation linked with the (throttle hold function (cut and idle positions), throttle cut function, and idle down function) is possible. The needle side cut position can be set. Set it to the fuel side full closed position.

MODEL MENU (AIRPLANE/GLIDER FUNCTIONS)

The dedicated mixes, etc. usable when airplane, glider, or EP glider model type is selected are displayed in this Model Menu functions section. First use the Model Type function of the Linkage Menu to preset the model type, wing type, and tail type matched to the fuselage used. Later setting resets the data set by mixing function, etc.

These dedicated mixes can be set for each flight condition, as required. When you want to use the system by switching the settings for each

condition by switch or stick position, use the Condition Select function to add flight conditions. (Up to 8 conditions can be used)

Note: The T12Z is designed so that the airplane and glider (including EP glider) model types can handle aircraft of the same wing type.

The functions common to airplanes and gliders, except some dedicated functions, are summarized without regard to the model type.

The setting items are different, depending on the number of servos, etc. according to the wing type used. The setup screens in the instruction manual are typical examples.

- Select the model menu icon at the home screen and call the model menu shown below by pushing the enter button.
- Use the cursor lever to select the function you want to set and call the setup screen by pushing the enter button..

(Model Menu screen example)

*The Model Menu screen depends on the model type. This screen is for model type 4AIL+4FLP.

- [Return Key]
- To home screen
 - To preceding screen

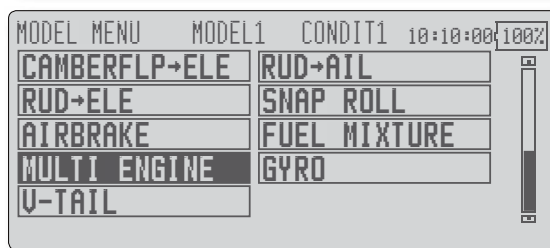
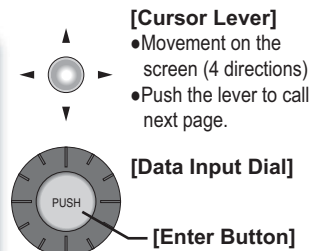
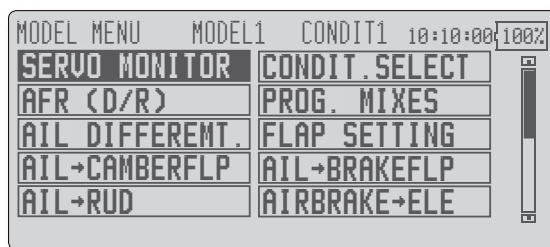

Model Menu functions list

AIL DIFFERENT.

This function adjusts the left and right ailerons. Roll axis correction and fine tuning with a VR are also possible. This is convenient when making settings during flight.

[Airplane/glider, 2 ailerons or more]

FLAP SETTING

The flaps can be adjusted independently. For a 4 flaps model, the camber flaps can be mixed with the brake flaps. [Airplane/glider, 2 flaps or more]

AIL to CAMBERFLP

This mix operates the camber flaps in the aileron mode. It improves the operation

characteristic of the roll axis. [Airplane/glider, 2 ailerons + 2 flaps or more]

AIL to BRAKEFLP

This mix operates the brake flaps in the aileron mode. It improves the operation characteristic of the roll axis. [Airplane/glider, 4 flaps or more]

AIL to RUD

This mix is used when you want to operate the rudder at aileron operation. Banking at a shallow bank angle is possible. [Airplane/glider, general]

AIRBRAKE to ELE

This mix is used to correct operation of the airbrakes (spoilers) when landing. [Airplane/glider, general]

RUD to AIL

This mix is used to correct roll maneuvers, knife edge, etc. of stunt planes. [Airplane/glider, general]

CAMBER Mix

This mix adjusts the camber and corrects the elevators. [Airplane/glider, 2 ailerons or more]

ELE to CAMBER

This mix is used when you want to the mix camber flaps with elevator operation. Lifting force can be increased at elevators up. [Airplane/glider, 2 ailerons or more]

CAMBERFLP to ELE

This mix is used to correct for attitude changes when the camber flaps are being used. [Airplane/glider, 2 ailerons + 1 flap or more]

BUTTERFLY (Crow)

This function is used when powerful brake operation is necessary. [Glider, 2 ailerons or more]

TRIM MIX 1/2

The ailerons, elevators, and flaps trim offset rate can be called by switch or condition selection. [Glider, 2 ailerons or more]

AIRBRAKE

This function is used when airbrakes are necessary when landing or when diving, etc. during flight. [Airplane, general]

GYRO

This is a dedicated mix when a GYA Series gyro is used. [Airplane/glider, general]

V-TAIL

This function adjusts the elevators and rudder of V-tail models. [Airplane/glider, V-tail specifications]

AILEVATOR

This function adjusts the elevators and ailerons of models with elevator specifications. [Airplane/glider, elevator specifications]

WINGLET

This function adjusts the left and right rudders of winglet models. [Airplane/glider, winglet specifications]

MOTOR

The operation speed when the motor of F5B and other EP gliders is started by switch can be set. [EP glider, general]

RUD to ELE

This function is used to correct roll maneuvers, knife edge, etc. of stunt planes. [Airplane, general]

SNAP ROLL

This function selects the snap roll switch and adjusts the steering angle of each rudder. Servo speed can also be adjusted. [Airplane general]

MULTI ENGINE

This function adjusts the throttles independently when using a multi engine model. (Maximum 4 engines) [Airplane, general]

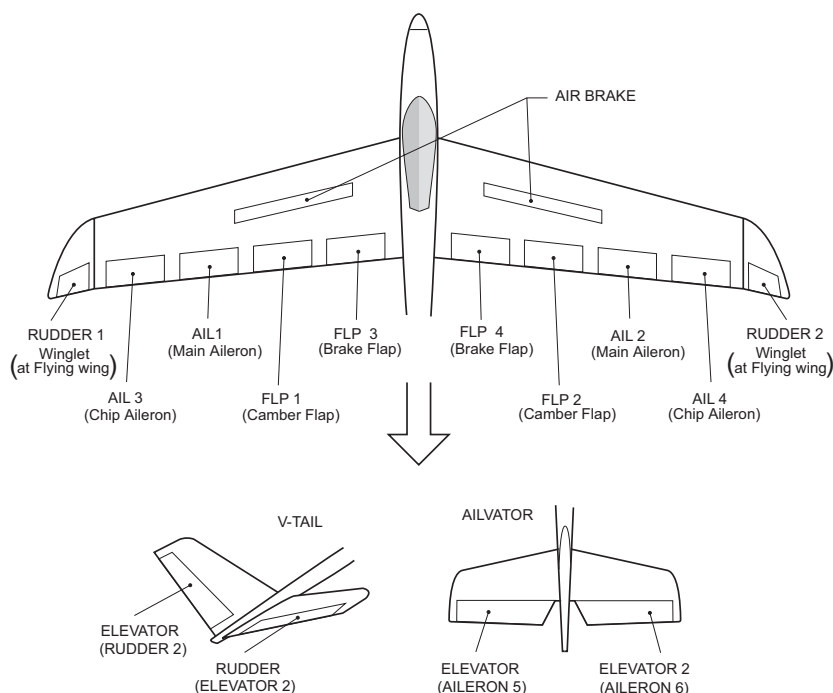

AIL DIFFERENT.

[Airplane/glider, 2 ailerons or more]

The left and right aileron differential can be adjusted independently. The differential rate can also be adjusted according to the flying state by setting a fine tuning VR.

- A fine tuning curve can be set.

Note: Aileron up/down setting (%) reset is +100% when reset when setting is +, and -100% when reset when setting is -. Left and right mixing causes + and - to change. Before flying, confirm the direction of operation.

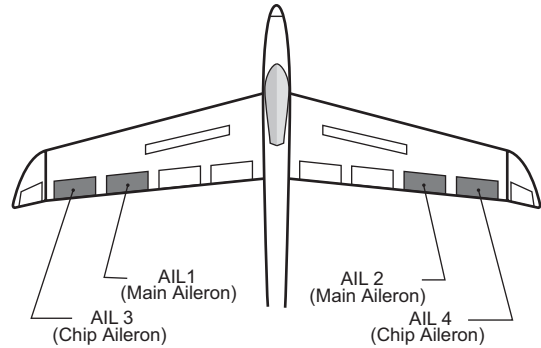

- Select [AIL DIFFERENT.] at the model menu and call the setup screen shown below by pushing the enter button.

[Return Key]

- To home screen
- To preceding screen

(Currently selected condition name)

[Cursor Lever]

- Movement on the screen (4 directions)
- Push the lever to call next page.

[Data Input Dial]

[Enter Button]

- Overall adjustment by Rate A and Rate B.
- Aileron left/right adjustment
- Group/single mode switching
- Calls the AFR screen directly when adjusting aileron operation AFR.

<Wing type: 4 ailerons screen>

*The display screen is an example. The actual screen depends on the Model Type.

*The display is reversed by mixing with aileron operation

Setting method

- Move the cursor to the aileron (AIL) 1~4 left (or right) setting item, and adjust the aileron angles when the stick is moved to the left (or right) end.
 - *The aileron AFR screen can be directly called from the AIL Differential setup screen. ([Master])
- When setting the fine tuning VR, move the cursor to the "NULL" item and push the enter button to call the <Switch> screen, and then select the fine tuning VR.
- The fine tuning rate can be set by curve.

FLAP SETTING

[Corresponding model type]: Airplane/glider, 2 flaps or more

The up/down travel of each flap (camber flaps: FLP1/2, brake flaps: FLP3/4) can be adjusted independently at each servo according to the wing type.

- The operation reference point of each flap can be offset

The camber flaps of a 4-flap model can be mixed with the brake flaps. (Brake FLP to camber FLP)

- An ON/OFF switch can be set.

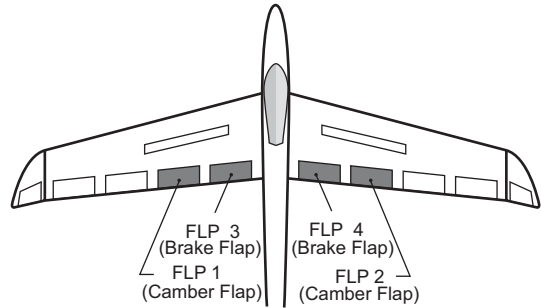

- Select [FLAP SETTING] at the model menu and call the setup screen shown below by pushing the enter button.

<Wing type: 4 flaps screen>

*The display screen is an example. The actual screen depends on the model type.

[Return Key]

- To home screen
- To preceding screen

(CAMBER FLP setting screen)

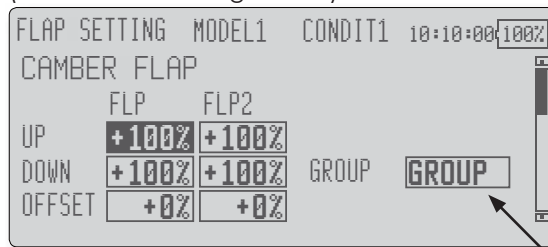

[Cursor Lever]

- Movement on the screen (4 directions)
- Push the lever to call next page.

[Data Input Dial]

[Enter Button]

(BRAKE FLP setting screen)

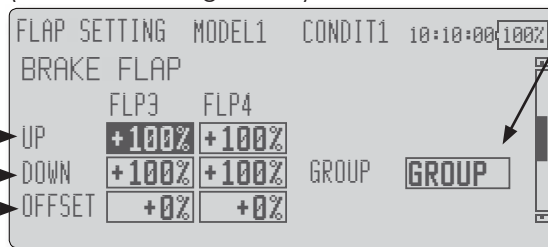

- Up side/Down side adjustment
- Operation reference point offset

- Group/single mode switching
(For more information, refer to the description at the back of this manual.)

(B.FLP to C.FLP setting screen)

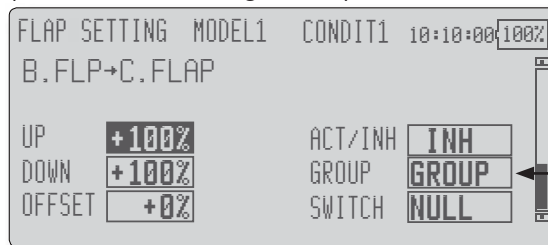

Setting method

- Move the cursor to the flap (FLP) 1~4 Up or Down item according to the wing type and adjust the travel independently.
- To offset the operation reference point of each flap, move the cursor to the corresponding Offset item. Use the data input dial to offset the reference point.
- When using Brake FLP to Camber FLP mixing, move the cursor to the [ACT/INH] item and turn the data input dial to the left and push the enter button. (ON is displayed.)

When setting a switch, move the cursor to the [NULL] item of the switch and push the enter button to call the <Switch> screen, and then select the switch and set its ON direction. (Always ON at "NULL" setting)
(For a description of the switch selection method, see the description at the back of this manual.)

AIL to CAMBERFLP [Corresponding model type]: Airplane/glider, 2 ailerons + 2 flaps or more

This mix operates the camber flaps (FLP1/2) in the aileron mode. When the aileron stick is manipulated, the ailerons and camber flaps perform aileron operation simultaneously and the operation characteristic of the roll axis is improved.

- The aileron left/right mixing rate of each flap servo can be fine-tuned.
- A mixing curve can be set.
- An ON/OFF switch can be set.
- Linking is possible: Link this mix to other mixes.

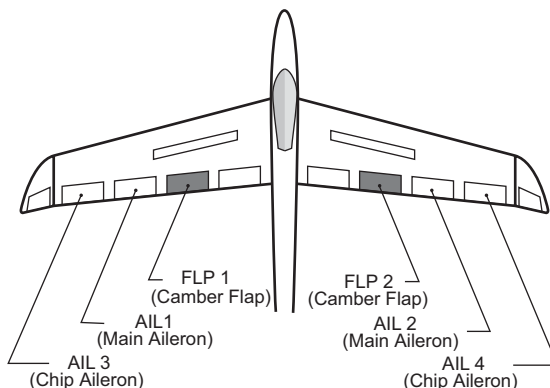

- Select [AIL to CAMBERFLP] at the model menu and call the setup screen shown below by pushing the enter button.

*The display screen is an example. The actual screen depends on the model type.

- [Return Key]
- To home screen
 - To preceding screen

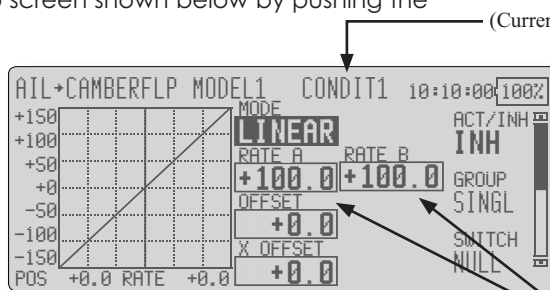

(Currently selected condition name)

- [Cursor Lever]
- Movement on the screen (4 directions)
 - Push the lever to call next page.

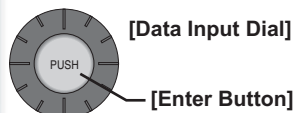

- Group/single mode switching
- (For more information, refer to the description at the back of this manual.)

- Mixing curve setting
- *For a description of the curve setting method, see the description at the back of this manual.

- Left/right overall adjustment at Rate A and Rate B

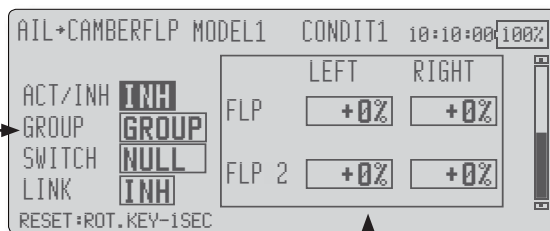

- Adjustment of each flap servo

Setting method

- Move the cursor to the ACT/INH item and turn the data input dial to the left and push the enter button. (ON is displayed.)
- When setting a switch, move the cursor to the [NULL] item of the switch and push the enter button to call the <Switch> screen, and then select the switch and set its ON direction. (Always ON at "NULL" setting)
(For a description of the switch selection method, see the description at the back of this manual.)
- Move the cursor to the left or right item of each flap servo, and adjust the mixing rate with the data input dial.

*When the mixing direction is reversed by the linkage, adjustments can be made by changing the mixing rate polarity (+ or -).

- A mixing curve can be set.
(For a description of the mixing curve setting method, see the description at the back of this manual.)
- To set linking, move the cursor to the Link item and set it to ON.

AIL to BRAKEFLP

[Corresponding model type]: Airplane/glider, 4 flaps or more

This mix operates the brake flaps (FLP3/4) in the aileron mode. When the aileron stick is manipulated, the aileron and brake flaps perform the aileron operation simultaneously and the operation characteristic of the roll axis is improved.

- The aileron left and right mixing rates can be adjusted for each flap servo.
- A mixing curve can be set.
- Mixing during flight can be turned ON/OFF by setting a stick. (Always ON at INH setting)
- Linking can be set: Link this mix to other mixes.

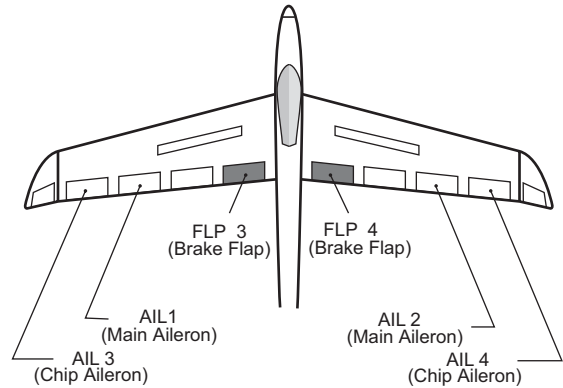

- Select [AIL to BRAKEFLP] at the model menu and call the setup screen shown below by pushing the enter button.

*The display screen is an example. The actual screen depends on the model type.

[Return Key]

- To home screen
- To preceding screen

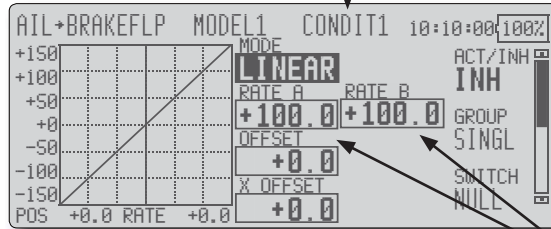

(Currently selected condition name)

[Cursor Lever]

- Movement on the screen (4 directions)
- Push the lever to call next page.

[Data Input Dial]

[Enter Button]

- Group/single mode switching

(For more information, refer to the description at the back of this manual.)

- Mixing curve setting

*For a description of the curve setting method, see the description at the back of this manual.

- Left/right overall adjustment at Rate A and Rate B

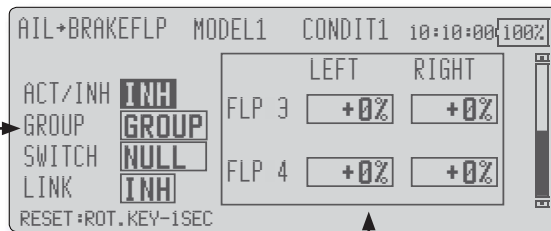

- Adjustment of each flap servo

Setting method

- Move the cursor to the ACT/INH item and turn the data input dial to the left and push the enter button. (ON is displayed.)
- When setting a switch, move the cursor to the [NULL] item of the switch and push the enter button to call the <Switch> screen, and then select the switch and set its ON direction. (Always ON at "NULL" setting)
(For a description of the switch selection method, see the description at the back of this manual.)
- Move the cursor to the left or right button of each flap servo, and adjust the mixing rate with the data input dial.

*When the mixing direction is reversed by the linkage,

adjustments can be made by reversing the mixing rate polarity (+ or -).

- A mixing curve can be set.
(For a description of the curve setting method, see the description at the back of this manual.)
- To set linking, move the cursor to the Link item and set it to ON.

Use this mix when you want to mix the rudders with aileron operation.

- A mixing curve can be set.
- Mixing during flight can be turned ON/OFF by setting a switch. (Always ON at NULL setting)
- The mixing rate can be fine-tuned by setting a VR.

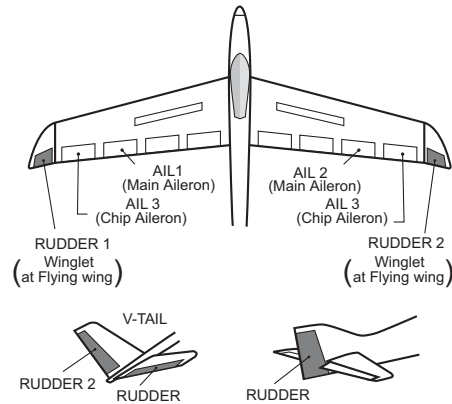

- Select [AIL to RUD] at the model menu and call the setup screen shown below by pushing the enter button.

- [Return Key]
 - To home screen
 - To preceding screen

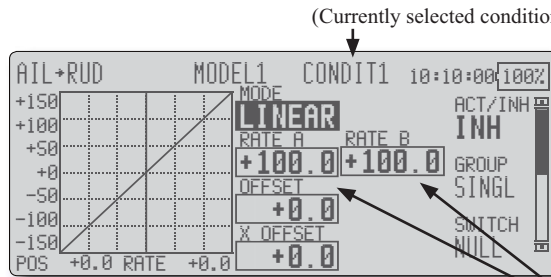

- [Cursor Lever]
 - Movement on the screen (4 directions)
 - Push the lever to call next page.
- [Data Input Dial]
 - [Enter Button]

- Group/single mode switching

(For more information, refer to the description at the back of this manual.)

- Mixing curve setting
 - *For a description of the curve setting method, see the description at the back of this manual.

- Left/right overall adjustment at Rate A and Rate B

*The display screen is an example. The actual screen depends on the model type.

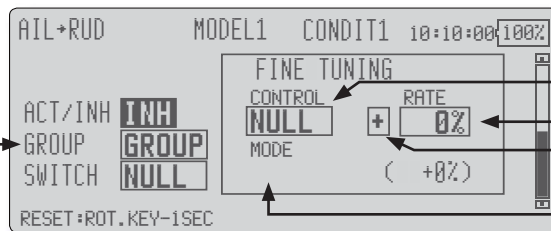

- Fine tuning VR setting
- Adjustment rate
- Adjustment direction
- Operation mode

Setting method

- Move the cursor to the ACT/INH item and turn the data input dial to the left and push the enter button. (ON is displayed.)
- When setting a switch, move the cursor to the [NULL] item of the switch and push the enter button to call the <Switch> screen, and then select the switch and set its ON direction. (Always ON at "NULL" setting)
(For a description of the switch selection method, see the description at the back of this manual.)
- When setting a VR, move the cursor to the Fine Tuning "NULL" item and push the enter button to call the <Switch> screen, and then select the VR. The adjustment rate and direction can be set. The VR operation mode can also be selected.
- A mixing curve can be set.
(For a description of the curve setting method, see the description at the back of this manual.)

[Fine tuning VR operation mode]



Mixing rate 0% at center of VR. When the VR is turned clockwise and counterclockwise, the mixing rate increases and decreases, respectively.



Mixing rate 0% at left end of VR. When the VR is turned, the mixing rate increases.



Mixing rate 0% at right end of VR. When the VR is turned, the mixing rate increases.



When the VR is turned to the left or right of the neutral position, the mixing rate increases.

AIRBRAKE to ELE

[Corresponding model type]: Airplane/glider, general

This mix is used when you want to mix the elevators with airbrake (spoiler) operation. It raises the elevators to correct for dropping of the nose during airbrake operation.

*This function does not operate when airbrake is not assigned at the Function menu in the Linkage Menu.

- The Rate 1 side/Rate 2 side mixing rate with the elevator servos can be adjusted.
- A mixing curve can be set.
- Mixing during flight can be turned ON/OFF by setting a switch. (Always ON at NULL setting)
- The mixing rate can be fine-tuned by setting a VR.

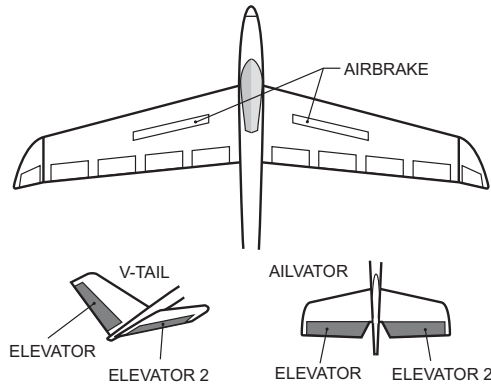

- Select [AIRBRAKE to ELE] at the model menu and call the setup screen shown below by pushing the enter button.

*The display screen is an example. The actual screen depends on the model type.

(Currently selected condition name)

[Return Key]

- To home screen
- To preceding screen

[Cursor Lever]

- Movement on the screen (4 directions)
- Push the lever to call next page.

[Data Input Dial]

[Enter Button]

- Group/single mode switching

(For more information, refer to the description at the back of this manual.)

• Mixing curve setting
*For a description of the curve setting method, see the description at the back of this manual.

• Overall adjustment by Rate A and Rate B.

- Fine tuning VR setting
- Adjustment rate
- Adjustment direction
- Operation mode

- Adjustment of each elevator servo

Setting method

- Move the cursor to the ACT/INH item and turn the data input dial to the left and push the enter button. (ON is displayed.)
- When setting a switch, move the cursor to the [NULL] item of the switch and push the enter button to call the <Switch> screen, and then select the switch and set its ON direction. (Always ON at "NULL" setting)
(For a description of the switch selection method, see the description at the back of this manual.)
- When setting a VR, move the cursor to the Fine tuning "NULL" item and push the enter button to call the <Switch> screen, and then select the VR. The adjustment rate and direction can be set. The VR operation mode can also be set.
(For a description of the fine tuning VR setting method, see the description at the back of this manual.)
- A mixing curve can be set.
(For a description of the curve setting method, see the description at the back of this manual.)

[Fine tuning VR operation mode]



Mixing rate 0% at center of VR. When the VR is turned clockwise and counterclockwise, the mixing rate increases and decreases, respectively.



Mixing rate 0% at left end of VR. When the VR is turned, the mixing rate increases.



Mixing rate 0% at right end of VR. When the VR is turned, the mixing rate increases.



When the VR is turned to the left or right of the neutral position, the mixing rate increases.

RUD to AIL

[Corresponding model type]: Airplane/glider, general

This function is used when you want to mix the ailerons with rudder operation. It is used when rudder is applied during roll maneuvers, knife edge, etc. of stunt planes. It can be used to bank scale models, large models, etc. like a full size plane.

- A mixing curve can be set.
- Mixing during flight can be turned ON/OFF by setting a switch. (Always ON at [NULL] setting)
- Linking can be set: Link this mix to other mixes.
- The mixing rate can be fine-tune by setting a VR.

- Select [RUD to AIL] at the model menu and call the setup screen shown below by pushing the enter button.

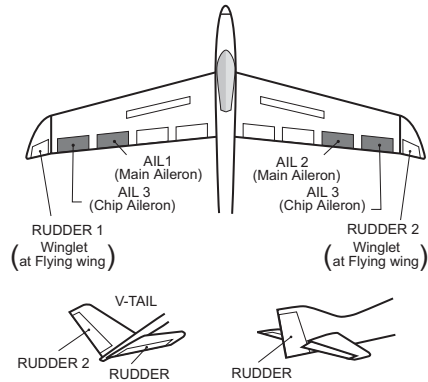

[Return Key]

- To home screen
- To preceding screen

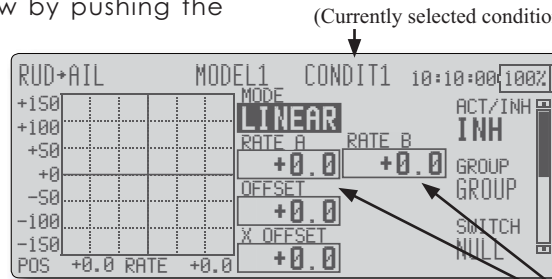

(Currently selected condition name)

[Cursor Lever]

- Movement on the screen (4 directions)
- Push the lever to call next page.

[Data Input Dial]

[Enter Button]

- Mixing curve setting

*For a description of the curve setting method, see the description at the back of this manual.

- Left/right overall adjustment at Rate A and Rate B

- Group/single mode switching

(For more information, refer to the description at the back of this manual.)

*The display screen is an example. The actual screen depends on the model type.

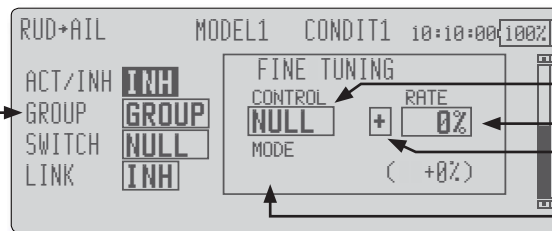

- Fine tuning VR setting
- Adjustment rate
- Adjustment direction
- Operation mode

Setting method

- Move the cursor to the ACT/INH item and turn the data input dial to the left and push the enter button. (ON is displayed.)
- When setting a switch, move the cursor to the [NULL] item of the switch and push the enter button to call the <Switch> screen, and then select the switch and set its ON direction. (Always ON at "NULL" setting)
(For a description of the switch selection method, see the description at the back of this manual.)
- When setting a VR, move the cursor to the Fine tuning "NULL" item and push the enter button to call the <Switch> screen and then select the VR. The adjustment rate and adjustment direction can be set.
The VR operation mode can also be set.
(For a description of the fine tuning VR setting method, see the description at the back of this manual.)

- A mixing curve can be set.
(For a description of the curve setting method, see the description at the back of this manual.)
- When linking: move the cursor to the Link item and set it to ON.

[Fine tuning VR operation mode]



Mixing rate 0% at center of VR. When the VR is turned clockwise and counterclockwise, the mixing rate increases and decreases, respectively.



Mixing rate 0% at left end of VR. When the VR is turned, the mixing rate increases.



Mixing rate 0% at right end of VR. When the VR is turned, the mixing rate increases.



When the VR is turned to the left or right of the neutral position, the mixing rate increases.

CAMBER MIX

[Corresponding model type]: Airplane/glider, 2 ailerons or more

This function adjusts the AFR (D/R) rate of camber operation which operates the wing camber (ailerons, camber flaps, brake flaps) in the negative and positive directions. The aileron, flap, and elevator rates can also be adjusted independently by curve, and attitude changes caused by camber operation can be corrected.

*Initial setting assigns camber operation to side lever LS.

- The up/down side rates of the aileron, flap, and elevator servos can be adjusted by curve. When the mixing direction is reversed by the linkage, adjustments can be made by changing the mixing rate polarity (+ or -).

- Select [CAMBER MIX] at the model menu and call the setup screen shown below by pushing the enter button.

- Mixing during flight can be turned ON/OFF by setting a switch. (Always ON at NULL setting)
- A delay can be set for each condition. A cut switch which can turn OFF the delay function can be set.
- The speed of the aileron, flap, and elevator servos can be set. (IN side/OUT side)

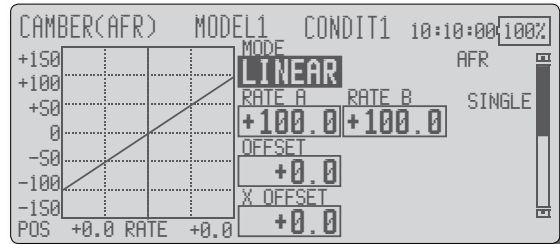

- Camber AFR (D/R) setup screen call (For a description of the setting method, refer to the AFR function.)

[Return Key]

- To home screen
- To preceding screen

(Currently selected condition name)

[Cursor Lever]

- Movement on the screen (4 directions)
- Push the lever to call next page.

[Data Input Dial]

[Enter Button]

• Condition delay setting

• Condition delay cut switch

(Curve/rate setting screen)

• Overall adjustment by Rate A and Rate B

- Mixing curve setting
- *For a description of the curve setting method, see the description at the back of this manual.

• Aileron rate adjustment

• Servo speed setting (For a description of the setting method, see the description at the back of this manual.)

*The display screen is an example. The actual screen depends on the model type.

Setting method

- Move the cursor to the ACT/INH item and turn the data input dial to the left and push the enter button. (ON is displayed.)
- When setting a switch, move the cursor to the [NULL] item of the switch and push the enter button to call the <Switch> screen, and then select the switch and set its ON direction. (Always ON at "NULL" setting)
(For a description of the switch selection method, see the description at the back of this manual.)
- When setting a condition delay, move the cursor to the Condition Delay item and set the delay with the data input dial.
- Camber AFR(D/R) screen call
Move the cursor to the Camber AFR item and push the enter button to call the setup screen.
(For a description of the setup method, see the description at the back of this manual.)

(Curve/rate setup screen)

- The curve and rate are adjusted by calling the aileron, flap, and elevator curve/rate screens. The rate and curve of each servo can be set by calling each screen. (For a description of the curve setting method, see the description at the back of this manual.)
The servo speed can also be adjusted.

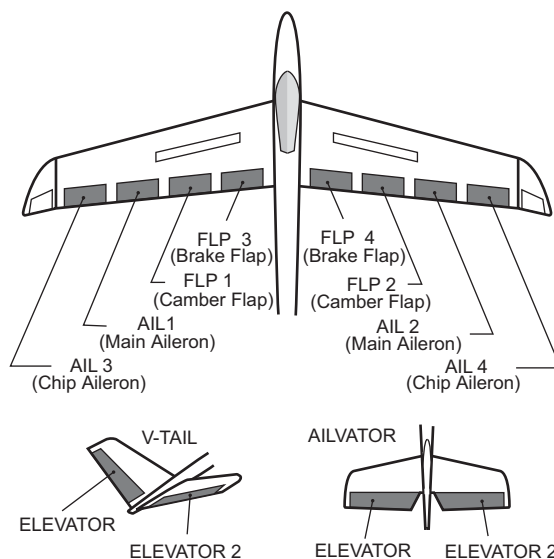

This function is used when you want to mix the camber flaps with elevator operation. When used, the flaps are lowered by up elevator, and lift can be increased.

- A mixing curve can be set.
- Mixing during flight can be turned ON/OFF by setting a switch. (Always ON at NULL setting)
- The mixing rate can be fine-tuned by setting a VR.

- Select [ELE to CAMBER] at the model menu and call the setup screen shown below by pushing the enter button.

*The display screen is an example. The actual screen depends on the model type.

- [Return Key]**
- To home screen
 - To preceding screen

- Mixing curve setting
*For a description of the curve setting method, see the description at the back of this manual.

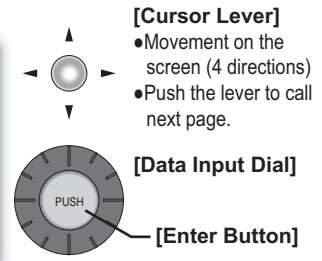
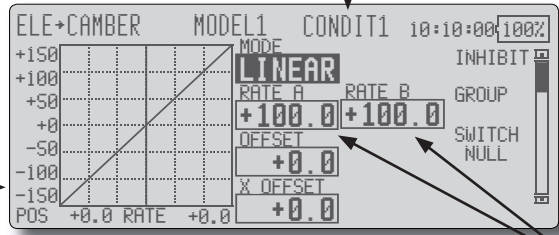

- Overall adjustment by Rate A and Rate B.

(Ailerons and flaps rate adjustment screen)

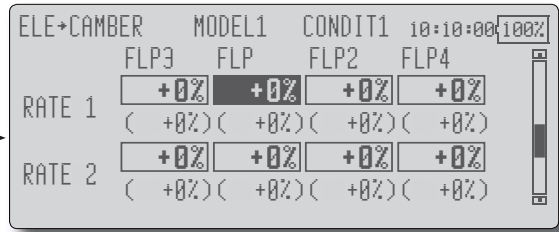
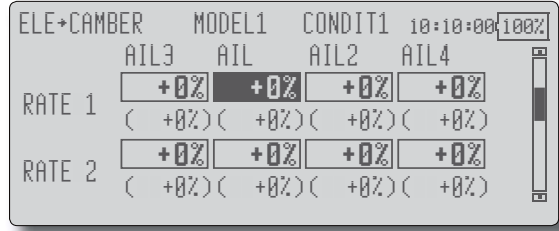

- Group/single mode switching
(For more information, refer to the description at the back of this manual.)

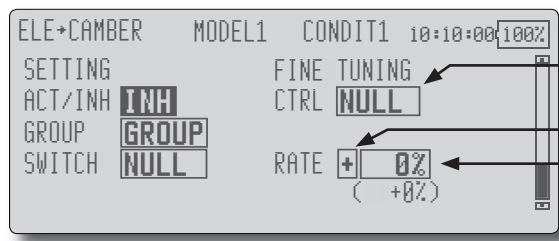

- Fine tuning VR setting
- Adjustment direction
- Adjustment rate

Setting method

- Move the cursor to the ACT/INH item and turn the data input dial to the left and push the enter button. (ON is displayed.)
- When setting a switch, move the cursor to the [NULL] item of the switch and push the enter button to call the <Switch> screen, and then select the switch and set its ON direction. (Always ON at "NULL" setting)
(For a description of the switch selection method, see the description at the back of this manual.)

- When setting a VR, move the cursor to the Fine tuning "NULL" item and push the enter button to call the <Switch> screen, and then select the VR. The adjustment rate and adjustment direction can be set.
The VR operation mode can also be selected.
- A mixing curve can also be set.
(For a description of the curve setting method, see the description at the back of this manual.)

CAMBERFLP to ELE

[Corresponding model type]: Airplane/glider,
2 ailerons + 1 flap or more

This mixing is used to correct changes (elevator direction) generated when the camber flaps (speed flaps) are used.

- The elevator servos up side/down side rate can be adjusted. When the mixing direction is reversed by the linkage, adjustments can be made by changing the mixing rate polarity (+ or -).
- A mixing curve can be set.
- Mixing during flight can be turned ON/OFF by setting a switch. (Always ON at NULL setting)
- The mixing rate can be fine-tuned by setting a VR.

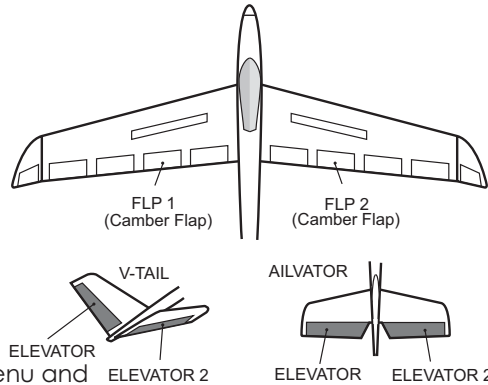

- Select [CAMBERFLP to ELE] at the model menu and call the setup screen shown below by pushing the enter button.

[Return Key]

- To home screen

- To preceding screen

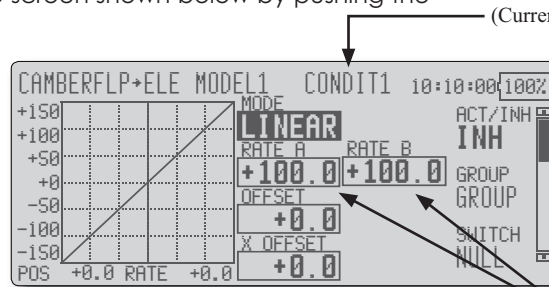

[Cursor Lever]

- Movement on the screen (4 directions)
- Push the lever to call next page.

[Data Input Dial]

[Enter Button]

- Mixing curve setting

*For a description of the curve setting method, see the description at the back of this manual.

- Group/single mode switching

(For more information, refer to the description at the back of this manual.)

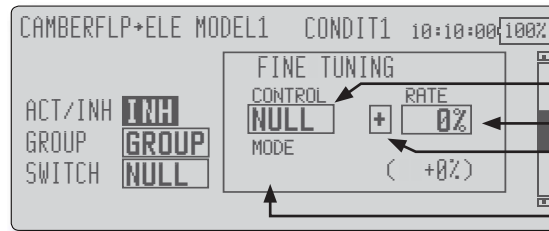

- Overall adjustment by Rate A and Rate B.

- Fine tuning VR setting

- Adjustment rate

- Adjustment direction

- Operation mode

- Elevator rate adjustment

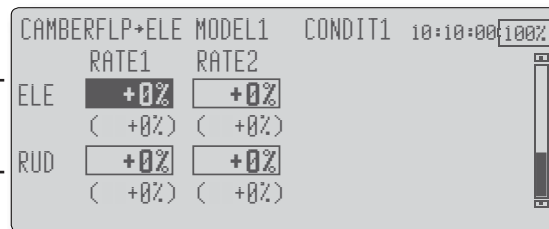

*The display screen is an example. The actual screen depends on the model type.

Setting method

- Move the cursor to the ACT/INH item and turn the data input dial to the left and push the enter button. (ON is displayed.)
- When setting a switch, move the cursor to the [NULL] item of the switch and push the enter button to call the <Switch> screen, and then select the switch and set its ON direction. (Always ON at "NULL" setting)
(For a description of the switch selection method, see the description at the back of this manual.)
- Move the cursor to the elevator servos left and right item and adjust the mixing rate with the data input dial.

*When the mixing direction is reversed by the linkage, adjustments can be made by changing the mixing rate polarity (+ or -).

- When setting a VR, move the cursor to the Fine tuning "NULL" item and push the enter button to call the <Switch> screen, and then select the VR. The VR operation mode can be selected.
- A mixing curve can be set.
(For a description of the curve setting method, see the description at the back of this manual.)

BUTTERFLY

[Corresponding model type]: Glider, 2 ailerons or more

This function allows powerful brake operation by simultaneously raising the left and right ailerons and lowering the flaps (camber flap, brake flap).

This setting will allow the ailerons to be raised while the flaps are simultaneously lowered. Butterfly (Crow) produces an extremely efficient landing configuration by accomplishing the following:

1. Slow the aircraft's velocity.
2. Provide washout at the wing tips to reduce the tendency to tip stall.
3. Create more lift toward the center of the wing allowing it to fly at a slower speed

- Mixing during flight can be turned ON/OFF by setting a switch. (Always ON at NULL setting)
- The butterfly operation reference point can be offset. When the enter button is pushed with the Offset item selected when operated to the position to be changed, the reference point is offset. If the reference point is offset too much, unexpected operation may be performed.
- The ailerons and flaps operation speed can be adjusted. (IN side/OUT side)
- A delay can be set for each condition. A cut switch which can turn OFF the delay function can also be set.
- The differential rate can be adjusted.

*When servo binding occurs when setting the ailerons and flaps in butterfly mixing, use the AFR function to adjust the rudder angle.

- Select [BUTTERFLY] at the model menu and call the setup screen shown below by pushing the enter button.

*The display screen is an example. The actual screen depends on the model type.

(Currently selected condition name)

[Return Key]

- To home screen
- To preceding screen

[Cursor Lever]

- Movement on the screen (4 directions)
- Push the lever to call next page.

[Data Input Dial]

[Enter Button]

• Select the Mixing Rate AIL and FLP box and adjust the mixing rates.

• To elevator correction setup screen

• Calls the Butterfly AFR (D/R) setup screen

- When using this function, move the cursor to the [ACT/INH] item and turn the data input dial to the left and push the enter button. (ON is displayed.)

(For a description of the setting method, see the description at the back of this manual.)

- Group/single mode switching (For more information, see the description at the back of this manual.)
- When setting a switch, select the SWITCH [NULL] box and press the enter button to call the <Switch> screen, and then select the switch and set its ON direction.

• Aileron and flap servos speed setting

(For a description of the setting method, see the description at the back of this manual.)

- When offsetting the butterfly operation reference point, operate to the point you want to change and then press the enter button.

• Differential rate adjustment

• Condition delay setting and cut switch setting (For a description of the setting method, see the description at the back of this manual.)

(Elevator correction rate setup screen)

- Overall adjustment by Rate A and Rate B

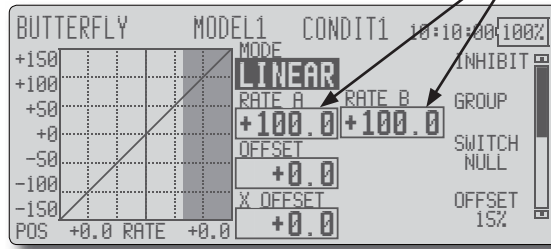

- Mixing curve setting
*For a description of the curve setting method, see the description at the back of this manual.

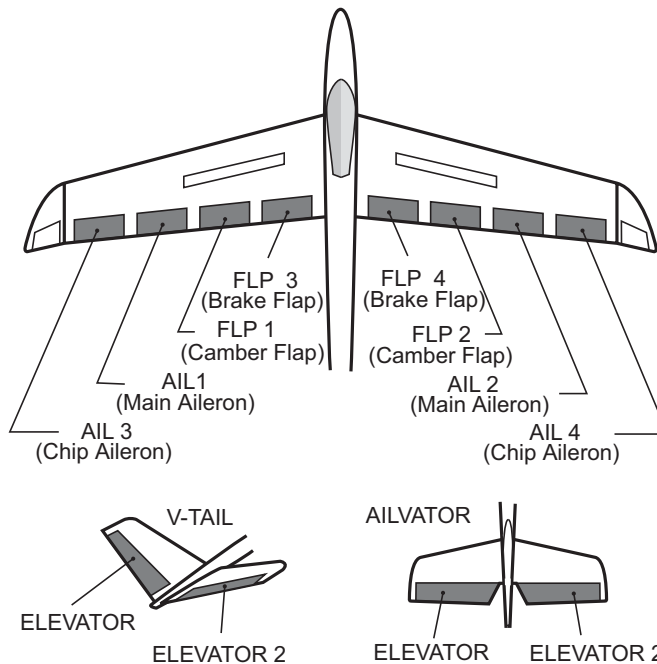
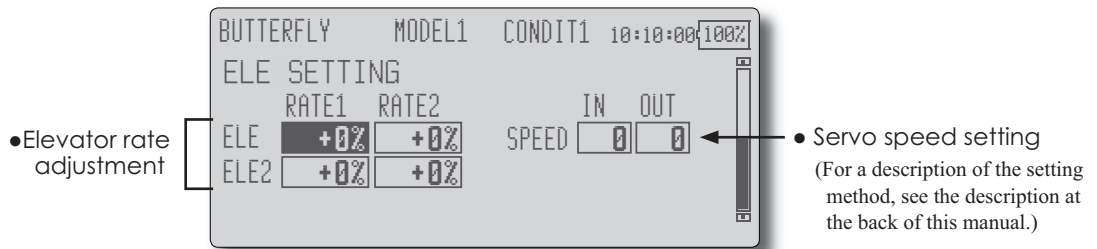

These functions call the ailerons, elevators, and flaps (camber flaps, brake flaps) trim offset rates preset according to the flight state.

The amount of ailerons, elevator, and flaps (camber flap, brake flap) trim offset can be set to a switch.

As an example **Trim Mix 1** can be set up for launching, with speed flaps and ailerons dropped, and a slight amount of up elevator. **Trim mix 2** can be used for high speed flying, with both ailerons and speed flaps reflexed slightly, and a bit of down elevator.

The trim functions can be activated during flight by setting a switch. To prevent sudden trim changes when switching flight conditions, a delay can be set to provide a smooth transition between the two. Trim Mix 2 will have priority over Trim Mix 1.

Example

1. Move to the ACT/INH item and set the trim mix function to [ON].
*When separating the settings for each condition, touch the group mode button and set it to [Single].
 2. Select the ON/OFF switch.
 3. Select the [Manual] or [Auto] mode.
In the [Auto] mode, also select an auto SW. This switch can be linked to a stick, etc.
- <Speed>
In: The operation speed at switch ON can be set.
Out: The return speed at switch OFF can be set.
- <Fine Tuning>
The offset rate can be varied in the Fine Tuning numeric range set at screen [1/2] by VR, etc. selection.
- <Condition Delay>
When flight conditions are set, the operation speed can be set for each condition. Condition delay operation can be interrupted and each rudder quickly returned to its original position by selecting a cut switch.

- Select [TRIM MIX1 or 2] at the model menu and call the setup screen shown below by pushing the enter button.

*The display screen is an example. The actual screen depends on the model type.

(Currently selected condition name)

[Return Key]
• To home screen
• To preceding screen

[Cursor Lever]
• Movement on the screen (4 directions)
• Push the lever to call next page.

[Data Input Dial]
[Enter Button]

The ailerons, flaps, and elevators offset rate can be adjusted. Move the cursor to the corresponding setting item and adjust the rate with the data input dial.

- When a fine tuning VR is set on the next page, the ailerons flaps and elevators trim rates can be adjusted. Move the cursor to the corresponding setting item and adjust the rate with the data input dial.

- When using this function, move the cursor to the [ACT/INH] item and turn the data input dial to the left and push the enter button. (ON is displayed.)

- Group/single mode switching
(For more information, see the description at the back of this manual.)

- Manual/Auto mode selection
Manual: Switches the function ON/OFF by switch
Auto: Trim mix function call can be linked to a stick, etc. A stick switch, etc. separate from the function ON/OFF switch is set.

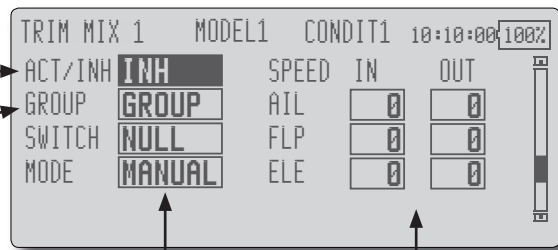

- Ailerons, flaps, an elevators servo speed setting
(For a description of the setting method, see the description at the back of this manual.)

- When using a fine tuning VR, move the cursor to this item and push the enter button to call the <Switch> screen.

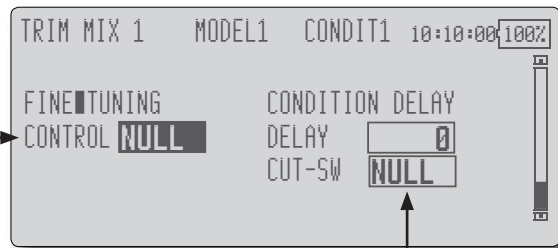

- Condition delay setting (for a description of the setting method, see the description at the back of this manual) and cut switch setting.

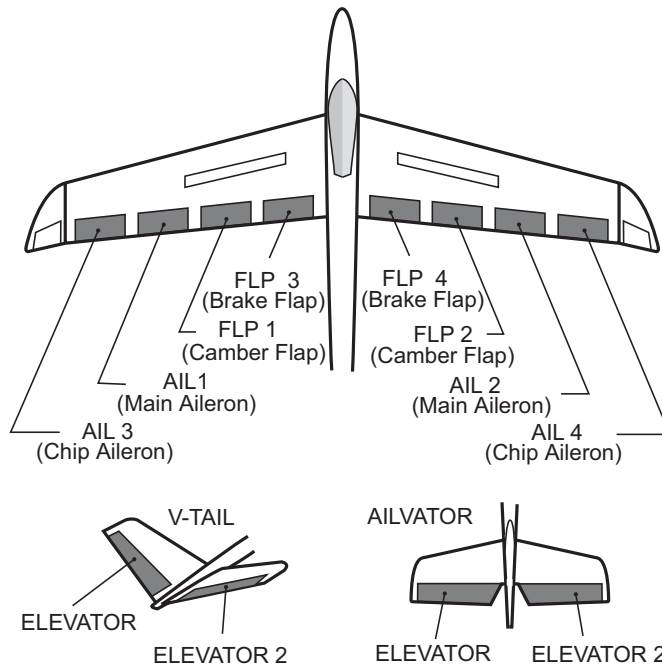

This function is used when an air brake is necessary when landing or diving, etc.

The preset elevators and flaps (camber flap, brake flap) offset amount can be activated by a switch.

The offset amount of the aileron, elevator, and flap servos can be adjusted as needed. Also the speed of the aileron, elevator, and flap servos can be adjusted. (IN side/OUT side) A delay can be set for each condition, and a Cut switch which will turn OFF the delay can be chosen. Trim amounts can be fine-tuned by setting a VR You can also set the Auto Mode, which will link Airbrake to a stick, switch, or dial. A separate stick switch or dial can also be set as the ON/OFF switch.

Setting example for F3A and other flaperon specifications

(When 2 ailerons model type selected)

Offset rate:

AIL: [-35~-45%], AIL2: [-35~-45%], ELE: [+5~7%]

Note: The input numerics are examples. Adjust the travel to match the aircraft.

Mode setting:

ACT: [ON]

Group: [Single]

Switch: [SW-C]

Mode: [Manual]

*The display screen is an example. The actual screen depends on the model type.

- Select [AIRBRAKE] at the model menu and call the setup screen shown below by pushing the enter button.

[Return Key]

- To home screen
- To preceding screen

(Currently selected condition name)

[Cursor Lever]

- Movement on the screen (4 directions)
- Push the lever to call next page.

[Data Input Dial]

[Enter Button]

The ailerons, flaps, and elevators offset rate can be adjusted. Move the cursor to the corresponding setting item and adjust the rate with the data input dial.

- When a fine tuning VR is set on the next page, the ailerons', flaps', and elevators' trim rates can be adjusted. Move the cursor to the corresponding setting item and adjust the rate with the data input dial.

- When using this function, move the cursor to the [ACT/INH] item and turn the data input dial to the left and push the enter button. (ON is displayed.)

- Group/single mode switching
(For more information, see the description at the back of this manual.)

- Manual/Auto mode selection
Manual: Switches the function ON/OFF by switch
Auto: Trim mix function call can be linked to a stick, etc. A stick switch, etc. separate from the function ON/OFF switch is set.

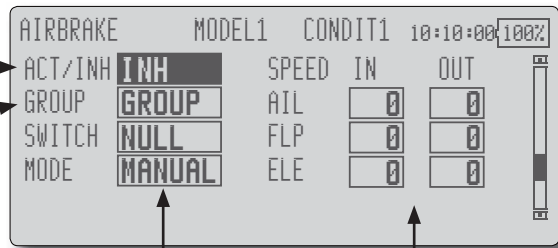

- Ailerons, flaps, an elevators servo speed setting
(For a description of the setting method, see the description at the back of this manual.)

- When using a fine tuning VR, move the cursor to this setting item and press the enter button to call the <Switch> screen.

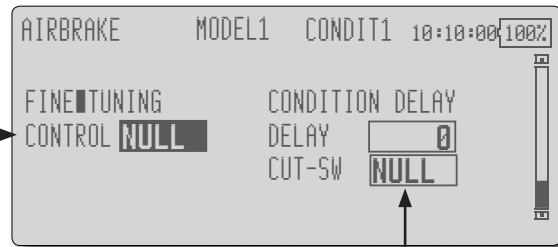

- Condition delay setting (for a description of the setting method, see the description at the back of this manual) and cut switch setting.

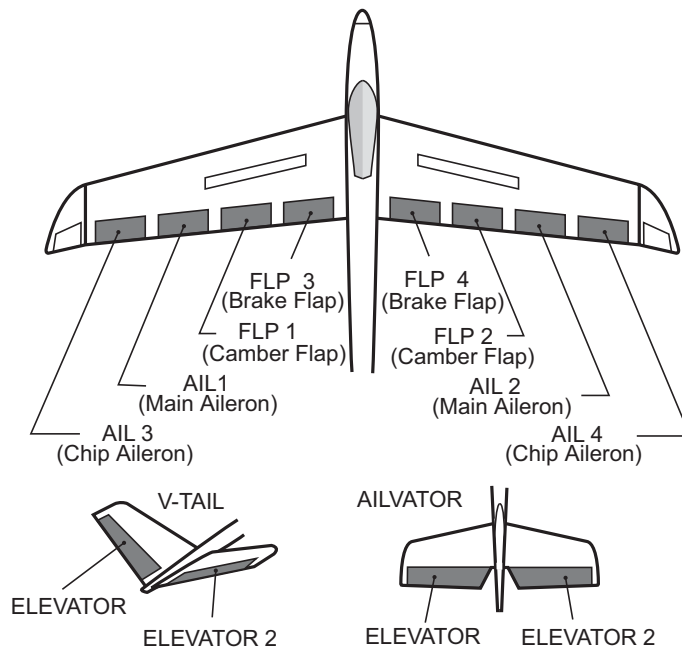

This function is used when a GYA Series gyro is used to stabilize the aircraft's attitude. The sensitivity and operation mode (Normal mode/GY mode) can be switched with a switch.

- Three rates (Rate 1/Rate 2/Rate 3) can be switched.
- Up to 3 axes (Gyro/Gyro 2/Gyro 3) can be simultaneously controlled.

*Initial setting does not assign a sensitivity channel. Use the Function menu of the Linkage Menu to assign the sensitivity channel (Gyro/Gyro2/Gyro3) used to a vacant channel beforehand.

Set [Control] and [Trim] other than Function to [NULL].

- Select [GYRO] at the model menu and call the setup screen shown below by pushing the enter button.

The screenshot shows the GYRO setup screen with the following fields:

GYRO	MODEL1	CONDIT1	10:10:00	100%
RATE 1 ²³				
ACT	INH	MODE	AVCS	0%
TYPE	GY	GYRO2	AVCS	0%
SWITCH	NULL	GYRO3	AVCS	0%
GROUP	GRP			

Annotations and controls:

- [Return Key]**:
 - To home screen
 - To preceding screen
- [Cursor Lever]**:
 - Movement on the screen (4 directions)
 - Push the lever to call next page.
- [Data Input Dial]**:
 - [Enter Button]

Additional notes from the diagram:

- Group/single mode switching (For more information, see the description at the back of this manual.)
- The operation mode (AVCS/NOR) and sensitivity of the 3 axes Gyro/Gyro2/Gyro3 can be set.

- Three rates (Rate 1/Rate 2/Rate 3) can be used.
- When using this function, move the cursor to the [ACT] item and turn the data input dial to the left and push the enter button.
- When a Futaba GYA gyro is used, when [GY] type is selected, the sensitivity set value is directly read in both the AVCS and NORM modes.
- When setting a switch, move the cursor to the SWITCH item and press the enter button to call the <Switch> screen, and then select the switch and set its ON direction.

(For a description of the switch selection method, see the description at the end of this manual.)

(Example) Setting 3 axes using a GYA351 and GYA352 (2 axes gyro)

- Wing type: Aileron 2 servos mounted fuselage selected
- Set Gyro 1 (GYA351): CH7, Gyro 2 (GYA352): CH8, Gyro 3 (GYA352): CH9 at the Function menu of the Linkage Menu.
- Rate 1 [OFF][GY][SW-E][GRP][NORM][60%][NORM][60%][NORM][60%]
 Rate 2 [INH][GY][NULL][GRP][AVCS][0%][AVCS][0%][AVCS][0%]
 Rate 3 [OFF][GY][SE-E][GRP][AVCS][60%][AVCS][60%][AVCS][60%]

*When separating the conditions, set to [SNGL].

*Set so that Rate 1 is turned on at the back position of switch E and Rate 3 is turned ON at the front position.

Since switch E is turned OFF at the center, Rate 2 remains [INH].

V-TAIL

[Corresponding model type]: Airplane/glider, V-tail

This function let's you adjust for left and right rudder angle changes at elevator and rudder operation of a V-tail airplane.

V-tail is when 2 servos are used together to control rudder movement as elevators. In addition to each rudder side moving up and down together, each side moves in opposite directions when moving as elevators. On a V-tail, this is also known as a Ruddervator, as they can serve the same purpose.

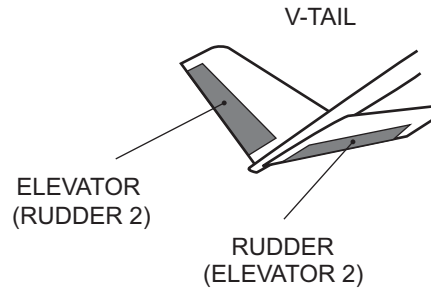

- Select [V-TAIL] at the model menu and call the setup screen shown below by pushing the enter button.
- Group/single mode switching (For more information, see the description at the back of this manual.)

(Currently selected condition name)

[Return Key]

- To home screen
- To preceding screen

V-TAIL	MODEL1	CONDIT1	10:10:00	100%
GROUP	GROUP			
FUNCTION	<--ELEVATOR-->		<---RUDDER--->	
	DOWN	UP	LEFT	RIGHT
ELE (RU2)	+50%	+50%	+50%	+50%
RUD (ELE2)	+50%	+50%	+50%	+50%

[Cursor Lever]

- Movement on the screen (4 directions)
- Push the lever to call next page.

[Data Input Dial]

[Enter Button]

(Elevator function) Up and down travel adjustment at CH1 and CH2 elevator operation

(Rudder function) Left and right travel adjustment at CH1 and CH2 rudder operation

AILEVATOR

[Corresponding model type]: Airplane/glider, V-Tail

(Effective only when 2 servos used at the elevators)

This function improves the operating performance of the roll axis by operating the elevators as ailerons.

Ailevator is where each elevator in a standard (conventional) or v-tail moves independently, like ailerons on a wing. In addition to each elevator side moving up and down together, each side moves in opposite directions when moving as an Ailevator. On a V-tail, this is also known as a Ruddervator, as they can serve the same purpose. Typically, both Ailevator and ailerons are coupled together to maximize roll performance, especially on larger wingspan planes.

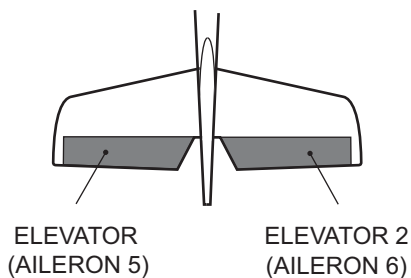

Note: Select Ailevator as the Model Type at the Model Type screen. This changes the output channel. Check the Function menu.

- Select [AILEVATOR] at the model menu and call the setup screen shown below by pushing the enter button.

[Return Key]

- To home screen

• To preceding screen

• Group/single mode switching
(For more information, see the description at the back of this manual.)

(Currently selected condition name)

AILEVATOR	MODEL1	CONDIT1	10:10:00	100%
GROUP	GROUP			
FUNCTION	<--ELEVATOR-->		<--AILERON-->	
	DOWN	UP	LEFT	RIGHT
ELE (AIL5)	+100%	+100%	+100%	+100%
ELE2(AIL6)	+100%	+100%	+100%	+100%

(Elevator function) (Aileron function)

[Cursor Lever]

- Movement on the screen (4 directions)
- Push the lever to call next page.

[Data Input Dial]

[Enter Button]

- The up and down rate of the left and right elevators when the elevator stick is manipulated can be individually adjusted.
- When the elevators are used as ailerons, aileron travel of the left and right elevators can be adjusted.

This function adjusts the left and right rudder angles of airplanes with winglets.

Winglets are used to improve the efficiency of aircraft lowering the lift-induced drag caused by wingtip vortices. The winglet is a vertical or angled extension at the tips of each wing.

Winglets work by increasing the effective aspect ratio wing without adding greatly to the structural stress and hence necessary weight of its structure - an extension of wing span would also permit lowering of induced drag, though it would cause parasitic drag and would require boosting the strength of the wing and hence its weight - there would come a point at which no overall useful saving would be made. A winglet helps to solve this by effectively increasing the aspect ratio without adding to the span of the wing.

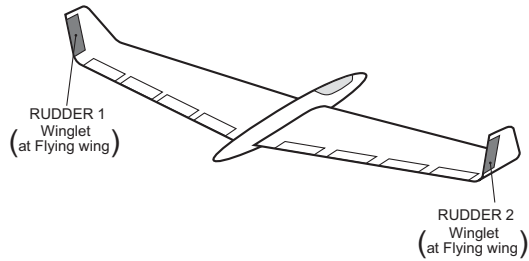

- Select [WINGLET] at the model menu and call the setup screen shown below by pushing the enter button.

[Return Key]

- To home screen
- To preceding screen

WINGLET MODEL1 CONDIT1 10:10:00 100%

GROUP **GROUP**

FUNCTION <---RUDDER---

	LEFT	RIGHT
RUDDER	+100%	+100%
RUDDER 2	+100%	+100%

• Group/single mode switching
(For more information, see the description at the back of this manual.)

(Currently selected condition name)

[Cursor Lever]

- Movement on the screen (4 directions)
- Push the lever to call next page.

[Data Input Dial]

[Enter Button]

(Rudder 1/2)

- The travel at rudder stick left and right operation can be individually set.

This function lets you set the operation speed when the motor of a F5B or other EP glider is started by switch. The operation speed can be set in 2 ranges of slow speed flight and high speed flight (Speed 1/Speed 2). This function can also be operated as a safety function by setting 2 switches.

- The In side and Out side operating speeds can be adjusted independently in 2 ranges (Speed 1/Speed 2).
- The boundary between the 2 ranges can be set. (From Speed 1 to Speed 2)
- The set operation speed operation can be activated at initial operation only. (1 time operation) However, operation can be repeated

by setting the switch to OFF before operation is finished. When you want to reset 1 time operation, set the ACT/INH item to [INH] and then reset it to [ON].

- The motor (CH3) is controlled by SW-G. (Initial setting) When changing the switch or stick which controls the motor, first change Function of the Linkage Menu.

Note: When using this function, always check initial operation with the propeller removed.

- Select [MOTOR] at the model menu and call the setup screen shown below by pushing the enter button.

- When using this function, move the cursor to the [ACT/INH] item and turn the data input dial to the left and push the enter button.
- Group/single mode switching (For more information, see the description at the back of this manual.)
- Switch
A switch that turns the function itself ON/OFF can be selected.
- Motor off position
Press the enter button when [SW-G] is in the motor OFF position. The direction of the motor switch is memorized. The screen graph display OFF direction also changes.

- Move the cursor by set switch or VR.

- Notes**
- First decide the motor OFF point, and then set the speed. When you want to reset the motor OFF point, also reset the speed.
 - We recommend that Motor OFF be set in combination with F/S.
 - Set the basic operation direction with the Reverse function to match the amp used.
 - Always set the Motor OFF position.

- When using this function, move the cursor to the [ACT/INH] item and turn the data input dial to the left and push the enter button.
- When you want to set the "One time mode", move the cursor to the [ONE TIME] item and turn the data input dial to the left and push the enter button.
- Speed 1 to 2
The Speed 1 and Speed 2 region boundary can be changed,
- Operation speed adjustment
The speed when Speed 1 and Speed 2 are ON (In) and OFF (Out) can be adjusted.

This function is used when you want to mix elevator operation with rudder operation. It is used to correct undesirable tendencies when rudder is applied in roll maneuvers, knife edge, etc. of stunt planes.

- A mixing curve can be set.
- Mixing during flight can be turned ON/OFF by setting a switch. (Always ON at NULL setting)

- Link can be set: Links this mixing to other mixings.
- The mixing rate can be fine-tuned by setting a VR. (Fine tuning)

- Select [RUD to ELE] at the model menu and call the setup screen shown below by pushing the enter button.

[Return Key]

- To home screen
- To preceding screen

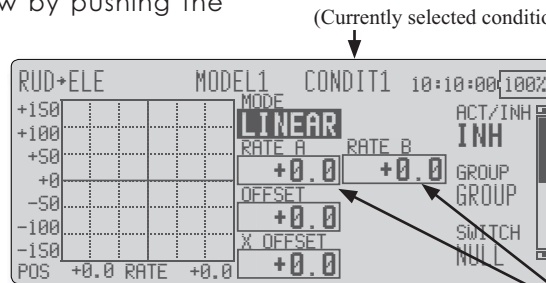

[Cursor Lever]

- Movement on the screen (4 directions)
- Push the lever to call next page.

[Data Input Dial]

[Enter Button]

- Mixing curve setting

*For a description of the curve setting method, see the description at the back of this manual.

- Left/right overall adjustment at Rate A and Rate B

- Group/single mode switching

(For more information, refer to the description at the back of this manual.)

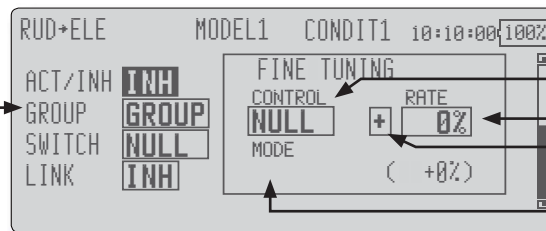

*The display screen is an example. The actual screen depends on the model type.

- Fine tuning VR setting
- Adjustment rate
- Adjustment direction
- Operation mode

Setting method

- Move the cursor to the ACT/INH item and turn the data input dial to the left and push the enter button. (ON is displayed.)
- When setting a switch, move the cursor to the [NULL] item of the switch and push the enter button to call the <Switch> screen, and then select the switch and set its ON direction. (Always ON at "NULL" setting)
(For a description of the switch selection method, see the description at the back of this manual.)
- When setting a VR, move the cursor to the Fine Tuning "NULL" item and push the enter button to call the <Switch> screen, and then select the VR. The fine tuning rate and adjustment direction can be set.
The VR operation mode can also be set.
(For a description of the fine tuning VR setting method, see the description at the back of this manual.)
- When setting Link, move the cursor to the Link item and set it to ON.

[Fine tuning VR operation mode]



Mixing rate 0% at center of VR. When the VR is turned clockwise and counterclockwise, the mixing rate increases and decreases, respectively.



Mixing rate 0% at left end of VR. When the VR is turned, the mixing rate increases.



Mixing rate 0% at right end of VR. When the VR is turned, the mixing rate increases.



When the VR is turned to the left or right of the neutral position, the mixing rate increases.

This function selects the switch and rate adjustment of each rudder, (ailerons, elevators, or flaps) when a snap roll is performed.

- Four snap roll directions can be set. (Right/up, right/down, left/up, left/down)
- Operation mode: When [Master] mode is selected, the Snap Roll function is turned ON/OFF by master switch in the state in which the direction switch was switched to the direction in which you want to snap roll. When [Single] mode is selected, snap roll in each direction can be executed by means of independent switches.
- A safety switch can be set. As a safety measure, the switch can be set so that snap roll is not executed when, for instance, the landing gear is lowered, even if the switch is turned on accidentally. The snap roll switch is activated only when the safety switch is ON.
- The operation speed of the aileron, elevator, and flap servos can be adjusted for each snap roll direction. (In side/Out side)

(Example) Setting example for F3A

- Mode: [Master]
- Safety SW: [SW-G] (Safety measure)
- Master SW: [SW-H] (Main switch for executing snap roll)
- Direction switches:
 - *The snap roll up side left and right and down side left and right direction switches are selected here.
 - Right/Up: OFF [SW-D]
 - Right/Down: OFF [SW-D]
 - Left/Up: OFF [SW-A]
 - Left/Down: OFF [SW-A]
- Speed adjustment

The operation speed of each control surface when the snap roll is ON can be changed and snap roll executed by stick while there is switch operation can be performed.

- Select [SNAP ROLL] at the model menu and call the setup screen shown below by pushing the enter button.

(Currently selected condition name)

[Return Key]

- To home screen
- To preceding screen
- Rate adjustment of each rudder

SNAP ROLL	MODEL1	CONDIT1	10:10:00	100%
RATE	AIL	ELE	RUD	
RIGHT/UP	+100%	+100%	+100%	
RIGHT/DOWN	+100%	-100%	-100%	
LEFT /UP	-100%	+100%	-100%	
LEFT /DOWN	-100%	-100%	+100%	

[Cursor Lever]

- Movement on the screen (4 directions)
- Push the lever to call next page.

[Data Input Dial]

[Enter Button]

• Group/single mode switching
(For more information, see the description at the back of this manual.)

SNAP ROLL	MODEL1	CONDIT1	10:10:00	100%
	ACT	SWITCH		
RIGHT/UP	OFF	NULL		
RIGHT/DOWN	OFF	NULL		
LEFT /UP	OFF	NULL		
LEFT /DOWN	OFF	NULL		

- Direction switches

SNAP ROLL	MODEL1	CONDIT1	10:10:00	100%
SPEED	<- AIL ->	<- ELE ->	<- RUD ->	
RIGHT/UP	IN OUT	IN OUT	IN OUT	
RIGHT/DOWN	0 0	0 0	0 0	
LEFT /UP	0 0	0 0	0 0	
LEFT /DOWN	0 0	0 0	0 0	

- Adjustment of the servo speed of each rudder
(For a description of the setting method, see the description at the back of this manual.)

MULTI ENGINE

[Corresponding model type]: Airplane, general

This function lets you adjust the throttle when using a multi engine airplane with up to 4 engines. The Throttle Cut function, Idle Down function, Throttle Hold function, High Trim, and Idle Trim can be adjusted by throttle channel (THR, THR2, THR3, THR4).

*Initial setting assigns only one throttle channel (THR). When using this function, the number of throttle channels must be assigned beforehand at the Function menu of the Linkage Menu.

- The throttle cut position can be set for each throttle channel. Throttle cut operation is linked to the switch set with the Throttle Cut function of the Linkage Menu.

*The throttle cut position set at this screen is effective.

- The idle down offset rate can be set for each throttle channel. Idle down operation is linked to the switch set with the Idle Down function of the Linkage Menu.

*The idle down offset rate set at this screen is effective.

- Operation can be fixed at the engine speed (carburetor opening angle) for each throttle channel with the Hold Position function. The hold position can be changed.

- High side trim and idle trim can be set for each channel. Operation acts as high trim or idle trim based on the center.

*The number of engines (1~4) assigned by Function menu in the Linkage Menu setup screen is displayed.

- Select [MULTI ENGINE] at the model menu and call the setup screen shown below by pushing the enter button.

[Return Key]

- To home screen

- To preceding screen

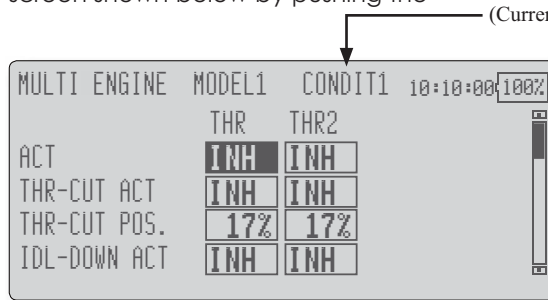

(Currently selected condition name)

[Cursor Lever]

- Movement on the screen (4 directions)
- Push the lever to call next page.

[Data Input Dial]

[Enter Button]

- Throttle cut position setting (for each engine)
- Idle down offset rate setting (for each engine)
- Throttle hold position setting
- High Trim setting (for each engine)

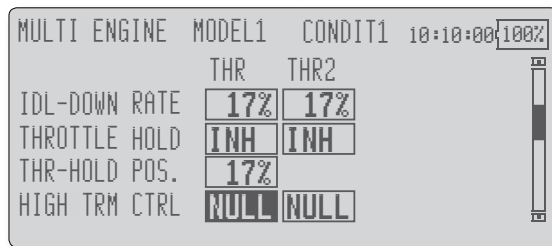

- Idle Trim setting (for each engine)

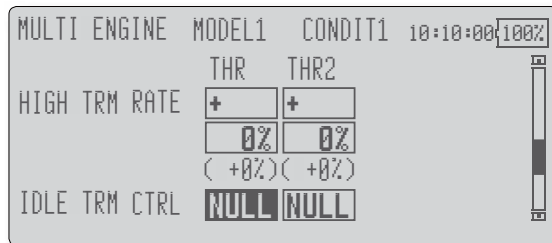

- Group/single mode switching (For more information, see the description at the back of this manual.)

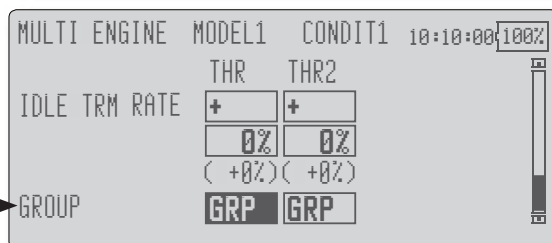

MODEL MENU (HELICOPTER)

This section contains information on the commands that apply to helicopters only. For instructions on Airplanes and Sailplanes, refer to the sections pertaining to those aircraft. Each of these functions can be set independently for different flight conditions. To get to these settings, move the cursor to the desired function and push the enter button to be entered.

Use the Model Type function in the Linkage Menu to select the swash type matched to the

fuselage beforehand. If you later change model types, all settings will be lost.

Also, add flight conditions at the Condition Select screen before setting the model data at each function. (Up to 8 conditions can be used)

The AFR function, fuel mixture and other functions common to all model types, are described in a separate section.

- Select the model menu icon at the home screen and call the model menu shown below by pushing the enter button.
- Use the cursor lever to select the function you want to set and call the setup screen by pushing the enter button..

[Return Key]
•To home screen

•To preceding screen

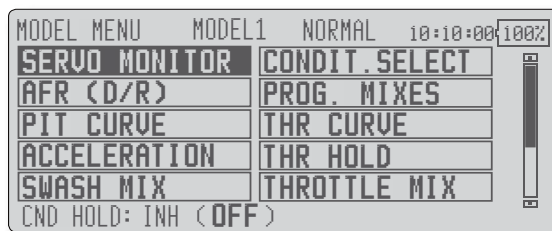

[Cursor Lever]
•Movement on the screen (4 directions)
•Push the lever to call next page.

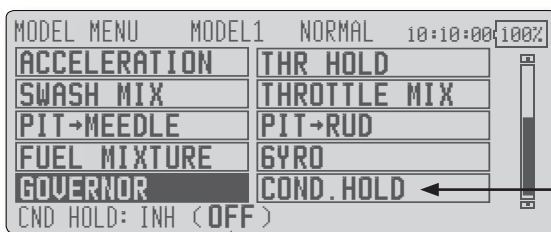
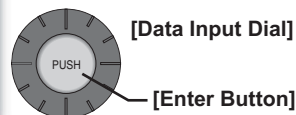

*Condition hold operation is displayed.

To activate/deactivate Condition Hold:

1. Move the cursor to [COND. HOLD].
2. Set the throttle stick lower than the 1/3 point and push the enter button to activate/deactivate the condition hold function.

*See p. 68 for condition hold function details.

Model Menu functions (helicopter) list

PIT CURVE: Adjusts response in different flight conditions

THR CURVE: Throttle curve and hovering trim adjustment

ACCELERATION: Allows a brief "overload" in response to sudden throttle and pitch commands

THR HOLD: Moves the throttle to idle during autorotation

SWASH MIX: Compensates for each control response

THROTTLE MIX: Compensates for power loss when cyclic applied

PIT to NEEDLE: Adjusts response curve in different flight conditions

PIT to RUD: Handles torque changes from pitch angle inputs

FUEL MIXTURE: Commands a second servo to adjust the fuel mixture at the carburetor

GYRO: Used to switch gyro sensitivity

GOVERNOR: Used to switch RPM of the helicopter's head

PIT CURVE/PIT TRIM

PIT Curve

This function adjusts the pitch operation curve for each flight condition for the optimal flight state relative to movement of the throttle stick.

*The pitch curve can be freely selected from linear operation curve to smooth curve, and adjusted to match the curve you want by means of the T12Z's powerful Curve Edit Function (6 types of curves can be selected). Up to 17 points can be

set for linear or curve types. However, when using the 3 points or 5 points specified to create a curve, a simple and smooth curve can be created by selecting the curve type and reducing the number of input points to 3 or 5, and then entering the specified value at the corresponding points that you created a curve.

- Select [PIT CURVE] at the model menu and call the setup screen shown below by pushing the enter button.

[Return Key]

- To home screen

- To preceding screen

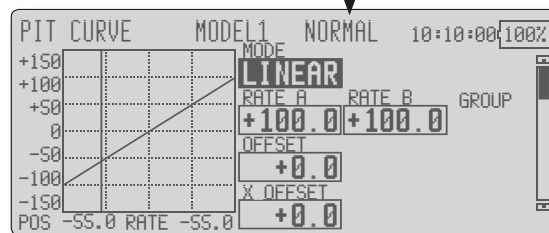

- Line type is 9 points, but for simple use, 4~5 points are sufficient.

[Cursor Lever]

- Movement on the screen (4 directions)
- Push the lever to call next page.

[Data Input Dial]

[Enter Button]

- Group/single mode switching

(For more information, refer to the description at the back of this manual.)

- Mixing curve setting

*For a description of the curve setting method, see the description at the back of this manual.

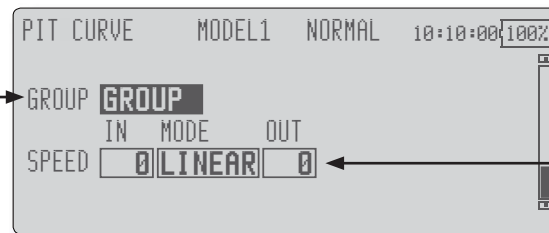

- Pitch servo speed setting

(For a description of the setting method, see the description at the back of this manual.)

Normal curve adjustment

- For normal curve, usually use [Line] type and create a basic pitch curve centered about hovering. Use this function together with the THR Curve (Normal) function and adjust the curve so that up/down control is best at a constant engine speed.

Idle up curve adjustment

- For the high side pitch curve, set the maximum pitch which does overload the engine. For the low side pitch curve, create curves matched to loop, roll, 3D, and other purposes and use the idle up curves according to the performance.

Note: When the curve type is changed, the data is reset.

Throttle hold curve adjustment

- The throttle hold curve is used when executing auto rotation dives.

Operation precautions

⚠ WARNING

- When actually starting the engine and flying, always set the idle up condition switch to [OFF] and start the engine in the idling state.

Setting method

- Group/Single item: When you also want to input the same setting contents at other conditions, perform setting in the group mode (initial setting). In this case, the same contents are input to the other conditions set in the group mode. When you want to set each condition independently, select the single mode. Other conditions can be set independently.
- The servo operation speed can be set.
- When increasing the number of points, move the cursor to POSITION item and rotate the data input dial to move to the point where you want to enter a point and push the enter button. The point is created.

Curve setting examples

The screens shown below are curves created by entering the pitch rate at low, center, and high side 3 points or 5 points at each condition. They were created by reducing the number of points to the 3 points of low side, center, and high side. When

actually creating a curve, input the rate specified at the fuselage (or the reference value).

*For a description of the curve setting method, see the description at the back of this manual.

•Pitch Curve (Example)

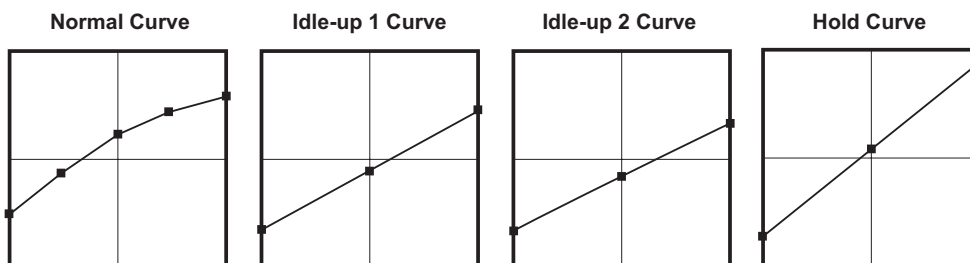

Pitch Trim (Hovering pitch, high pitch, low pitch)

The hovering pitch, low pitch, and high pitch trim setup screen can be called from the PIT Curve setup screen.

- Hovering pitch trim setting

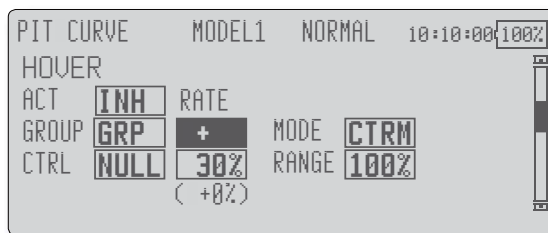

- Low/High pitch trim

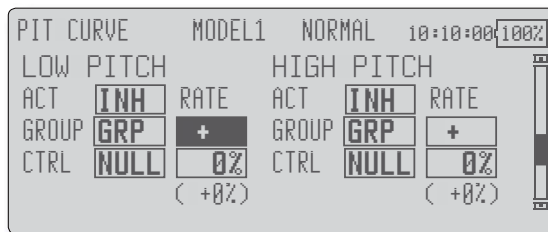

(Continued on next page)

Hovering pitch trim

The Hovering Pitch function trims the pitch near the hovering point. Normally, it is used with the hovering condition. The hovering pitch can be fine tuned for changes in rotor speed accompanying changes in temperature, humidity, and other flight conditions. Adjust the hovering pitch so that rotor speed is constant. This function can be used together with the Hovering Throttle Trim function for more delicate operation.

Setting method

- When using only the hovering (normal) condition, switch the group button to the single mode before setting.
- Set the function to ACT [ON].
- Select the adjustment knob. Selection example: LD
- The trim operation mode (Mode: CTRM/ NORM) can be selected.

CTRM mode: Maximum amount of change near center by center trim operation

NORM mode: Normal trim (parallel movement trim) operation. The advantage of using this mode is that the hovering pitch can be adjusted without changing the curve.

- Trim adjustment range (Range) setting
When this value is made small, trim can only be used near the center.
- The trim rate can be adjusted and the operation direction can be changed.

High Pitch/Low Pitch Trim

High Pitch/Low Pitch Trim is the pitch servo high side and low side trim function.

Setting method

- When setting the adjustment knobs common to all the conditions, set them in the group mode.
- Set the function to ACT (ON).
- Select the adjustment knobs. Selection example: LS (high side), RS (low side)
- The trim rate can be adjusted and the operation direction can be changed.
- Trim acts as high side or low side trim with the center as the standard.

THR CURVE/THROTTLE HOVER TRIM

THR Curve

This function adjusts the throttle operation curve for each condition for optimum the engine speed to throttle stick movement.

A throttle curve from linear operation curve to smooth curve can be set. Adjustment to the curve you want to use is possible by using the 12Z's powerful Curve Edit Function. Up to 17 curve

points can be set, however, when the 5 points and other point data is used, a smooth curve can be easily created by reducing the number of input points of the curve to 5 and entering the specified value at the corresponding points.

- Select [THR CURVE] at the model menu and call the setup screen shown below by pushing the enter button.

[Return Key]

- To home screen
- To preceding screen

(Currently selected condition name)

[Cursor Lever]

- Movement on the screen (4 directions)
- Push the lever to call next page.

[Data Input Dial]

[Enter Button]

Normal curve adjustment

- Normal curve creates a basic curve centered around hovering. Use it along with the normal pitch curve and adjust so that up/down control at a constant engine speed is easiest.

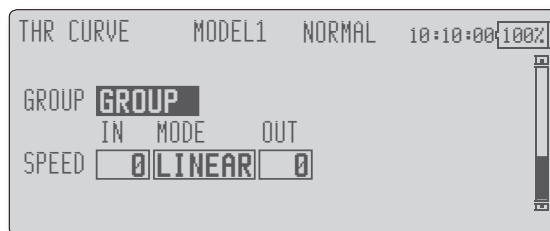

Idle up curve adjustment

- Set a idle up curve that maintains a constant speed at all times, even when operation which reduces the pitch was performed in flight. Create a curve matched to loop, roll, 3D, or other purposes and the idle up curve according to the performance.

Operation precautions

⚠ WARNING

- When actually starting the engine and flying, always set the idle up condition switch to [OFF] and start the engine in the idling mode.

Setting method

- Group/single item: When you want to simultaneously enter the same settings to other functions, make the settings in the group mode. (Initial setting) In this case, the same setting contents are entered to the other conditions in the group mode. When you want to set each condition independently, make the settings after selecting the single mode.
- The servo speed can be set.

Curve setting examples

The curves shown below were created by using the Line mode and inputting the data of the 5 points 0% (low side), 25%, 50% (center), 75%, 100% (high) side at each condition. They were created by reducing the number points of the line to 5. When

actually creating a curve, enter the data specified per the aircraft (or the reference value).

*For a description of the curve creation method, see the description at the back of this manual.

●Throttle Curve (Example)

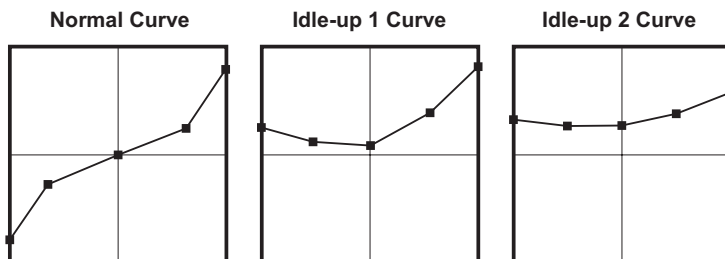

Throttle Hover trim

The Throttle Hover trim setup screen can be called from the THR Curve setup screen.

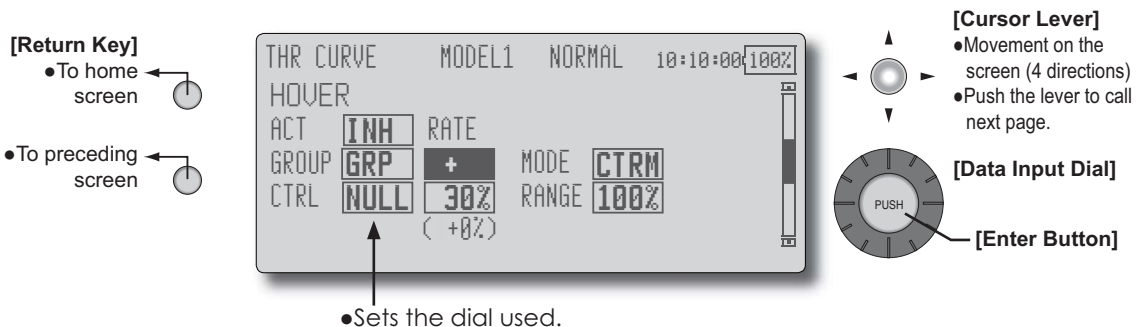

The Throttle Hover function trims the throttle near the hovering point. Normally, use it with hovering conditions. Changes in rotor speed accompanying changes in the temperature, humidity, and other flight conditions can be trimmed. Adjust the throttle so that rotor rotation is most stable. More delicate trimming is also possible by using this function along with the Hover Pitch function.

trim) operation. The advantage of using this mode is that hovering throttle can be adjusted without changing the curve.

- Trim adjustment range (Range) setting
When the value is made small, trim acts only near the center.
- The trim rate can be adjusted and the operation direction can be set.

Setting method

- When using the hovering (normal) condition only, switch the group mode to the single mode and make the settings.
- Set the function to ACT ([ON]).
- Select the adjustment knob. Selection example: RD
- The trim operation mode (Mode: CTRM/NORM) can be selected.

CTRM mode: Maximum rate of change near center by center trim operation

NORM mode: Normal trim (horizontal movement

ACCELERATION

This function is used to adjust the pitch and the throttle rise characteristic at acceleration/deceleration operation. An acceleration function which temporarily increases the pitch and throttle operations at throttle stick acceleration/deceleration operation can be set.

Example of acceleration function use

- When used at pitch, the Acceleration function is effective when you want to quicken the response of the fuselage at 3D flight flip, etc.

When used, high pitch temporarily exceeds maximum pitch, but immediately returns to maximum pitch.

- Select [ACCELERATION] at the model menu and call the setup screen shown below by pushing the enter button.

The diagram illustrates the ACCELERATION setup process. It shows two screens: 'ACCELERATION MODEL1 NORMAL 10:10:00 100%' for PITCH and THROTTLE. The PITCH screen displays settings for ACT/INH (INH), GROUP (GRP), RATE (LOW 0%, HIGH 0%), DUMPING (0%), and ACT POS (25%, 75%, 0%). The THROTTLE screen displays settings for ACT/INH (INH), GROUP (GRP), RATE (CLOSE 0%, OPEN 0%), DUMPING (0%), and ACT POS (25%, 75%, 0%). A graph on the right of each screen shows the operation point. Control instructions include: [Return Key] (To home screen, To preceding screen), [Cursor Lever] (Movement on the screen (4 directions), Push the lever to call next page), [Data Input Dial] (PUSH), and [Enter Button].

Setting method

- Acceleration can be set at both setting at acceleration (high) and setting at deceleration (low).
(The operation point is displayed on a graph.)
- Acceleration rate setting (Rate)
- The return time after operation (Dumping) can be set.
- The operation point at acceleration and deceleration can be set. When an operation point is exceeded, acceleration is performed.

Note: When using the Acceleration function, since the pitch stroke is large, make your settings so there is no binding of your linkage.

THR HOLD

This function sets the throttle cut position for auto rotation. The throttle position can also be set to an idling position separate from the throttle cut position. Setting of these 2 positions can be selected by switch. This allows use for switching during training.

Example of use

- Since Throttle Hold has 2 modes (Cut) and (Idle), using it in the Idling mode during training and in the Cut mode when stopping the engine at meets, etc. is convenient.

Note: When throttle hold is set to ON in the normal condition, throttle hold acts and the throttle servo is deactivated. Always set throttle hold to ON in the hold condition.

- Select [THR HOLD] at the model menu and call the setup screen shown below by pushing the enter button.

(Currently selected condition name)

[Return Key]

- To home screen
- To preceding screen

• Set to the engine stop position.

• Set to the idling position.

[Cursor Lever]

- Movement on the screen (4 directions)
- Push the lever to call next page.

[Data Input Dial]

[Enter Button]

- Select the SW to be used.

Setting method

- Operation mode selection
 - Manual mode(MANL):** The throttle hold function is operated by switch operation only.
 - Auto mode(AUTO):** The throttle hold function operation is linked to the throttle stick position.
 - Auto position setting:** When the Auto mode was selected, the throttle position (auto position) can be selected. Move the throttle stick to the position you want to set and push the enter button. (Auto position is displayed.)
- Hold position adjustment
 - Throttle Hold (Cut)** sets the throttle cut position. Adjust it so that the carburetor is full close.
 - Throttle Hold (Idle):** Make this adjustment to maintain idling for training. Adjustments can be made based on the throttle curve idle position.
- The throttle servo operating speed can be adjusted. (Speed)
- Throttle cut or training function can be switched by hold function selector switch.

Operation precautions

⚠ WARNING

- When starting the engine, confirm that the idle up condition and throttle hold condition are [OFF].

SWASH MIX

The swash mix function is used to correct the swash plate in the aileron (roll) direction and elevator (cyclic pitch) corresponding to each operation of each condition.

Adjustment by independent curve for aileron, elevator, and pitch operations is possible. The operation can be smoothly adjusted by calling up the "Curve setup" screen by pressing the enter button with moving the cursor to the mixing item that corresponds to the mixing and direction which needs correction.

Example of use

- As an example, use swash mixing to correct undesirable tendencies in the roll direction
- For a condition which uses AIL to ELE, set this function to ON. When raising the nose at a right roll, when the Rate B side is input and the right aileron is operated, the elevator moves to the down side. Tune by adjusting the Rate. For right roll, adjust to the Rate A side.

- Select [SWASH MIX] at the model menu and call the setup screen shown below by pushing the enter button.

(Currently selected condition name)

[Return Key]

- To home screen
- To preceding screen

[Cursor Lever]

- Movement on the screen (4 directions)
- Push the lever to call next page.

[Data Input Dial]

[Enter Button]

MIXING	ACT	SWITCH	TRIM	GROUP
AIL→ELE	INH	NULL	OFF	GROUP
ELE→AIL	INH	NULL	OFF	GROUP
PIT→AIL	INH	NULL		GROUP
PIT→ELE	INH	NULL		GROUP

AIL+ELE		MODEL1	NORMAL	10:10:00	100%
+150					
+100					
+50					
0					
-50					
-100					
-150					
POS	+0.0	RATE	+0.0		

Setting method

- When using this function, move the cursor to the [ACT] item and turn the data input dial to the left and push the enter button. (ON or OFF is displayed.)
- When you want to set the same contents at other conditions, select the group mode (Group). When you want to set the selected condition only, select the single mode (Single).
- The correction rate can be set by curve.
- A switch can be set.
When [NULL] is set, the swash mixing function is operated by merely selecting the condition.
When setting an [ON]/[OFF] switch, move the cursor to the [NULL] item and push the enter button to call the <Switch> screen and set the switch and its ON position.

THROTTLE MIX

This function corrects slowing of engine speed caused by swash plate operation at aileron or elevator operation. The method of applying clockwise or counterclockwise torque when pirouetting can also be corrected.

An acceleration function which temporarily increases the throttle side correction rate relative to rapid stick operation can also be set.

When correction is necessary, move the cursor to the

- Select [THROTTLE MIX] at the model menu and call the setup screen shown below by pushing the enter button.

[Return Key]

- To home screen

- To preceding screen

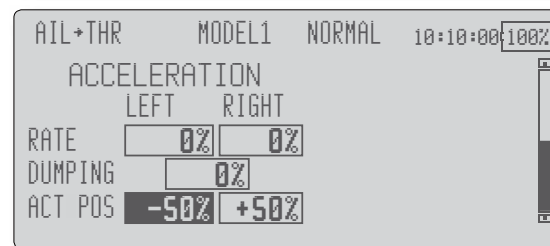
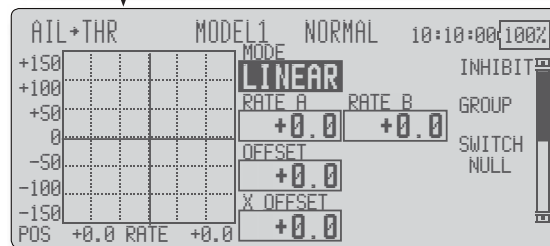
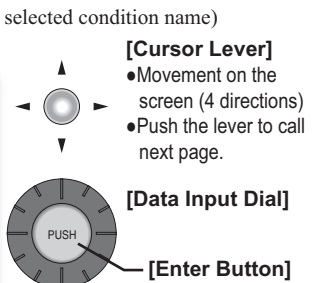
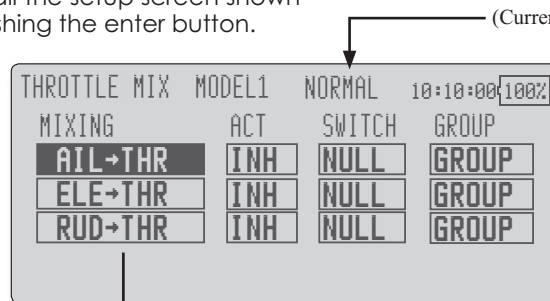

the mixing item corresponding to the mixing that needs correction and push the enter button to call the curve setup screen, and then correct the sinking.

Setting example

- AIL to THR applies a load to the engine and corrects sinking of the engine speed when the aileron stick was operated. Engine racing can be adjusted independently at the right aileron and left aileron by Rates A and B.

Setting method

- When using this function, move the cursor to the [ACT] item and turn the data input dial to the left and push the enter button. (ON or OFF is displayed.)
- When you want to set the same contents at other conditions, select the group model (Group).
When you want to set the selected condition only, select the single mode (Single).
- The correction rate can be set by curve.
- A switch can be set.
When [NULL] is set, the swash mixing function is operated by merely selecting the condition.
When setting an [ON]/[OFF] switch, move the cursor to the [NULL] item and push the enter button to call the <Switch> screen and set the switch and its ON position.

<Acceleration function setting>

- Acceleration can be set for both settings (Left) and (Right) at maximum correction rate.
- Acceleration rate setting (Rate)
- The return time (Dump.) after operation can be set.
- The operation point when the correction rate is increased and decreased can be set independently. When an operation point is exceeded, acceleration operation is performed.

PIT to NEEDLE mixing

This mixing is used when the engine is equipped with needle control or other fuel-air mixture adjustment. A needle curve can be set.

An acceleration function which temporarily increases needle operation at throttle stick

acceleration/deceleration operation can be set. The rise characteristic of the needle servo at acceleration and deceleration operation can be adjusted.

- Select [PIT to NEEDLE] at the model menu and call the setup screen shown below by pushing the enter button.
- Normally, use [Line] type.

[Return Key]

- To home screen
- To preceding screen

[Cursor Lever]

- Movement on the screen (4 directions)
- Push the lever to call next page.

[Data Input Dial]

[Enter Button]

(Currently selected condition name)

Setting method

- When using this function, move the cursor to the [ACT] item and turn the data input dial to the left and push the enter button. (ON or OFF is displayed.)
- When you want to set the same contents at other conditions, select the group model (Group).
When you want to set the selected condition only, select the single mode (Single).
- A needle curve can be set.
- A switch can be set.
When [NULL] is set, the swash mixing function is operated by merely selecting the condition. When setting an [ON]/[OFF] switch, move the cursor to the [NULL] item and push the enter button to call the <Switch> screen and set the switch and its ON position.

< Acceleration function setting >

- Acceleration can be set at both setting at acceleration (High) and setting at deceleration (Low).
- The acceleration rate (Rate) and the return time after operation (Dump.) can be set.
- An operation point (Act Pos) at acceleration and deceleration can be set. When an operation point was exceeded, acceleration operation is performed.

PIT to RUD mixing (Revolution mixing)

Use this mix when you want to suppress the reaction torque generated by main rotor pitch and speed changes at pitch operation. Adjust so that the nose does not move in the rudder direction.

An acceleration function which temporarily increases the correction rate at throttle stick acceleration/deceleration operation can be set. The mixing rate at acceleration/deceleration can be set.

However, when a GY Series or other heading hold gyro is used, since correction is performed by the gyro, this mix is not used. If this function is used when the gyro operation mode is the AVCS mode, the neutral position will change.

- Select [PIT to RUD] at the model menu and call the setup screen shown below by pushing the enter button.

[Return Key]

- To home screen
- To preceding screen

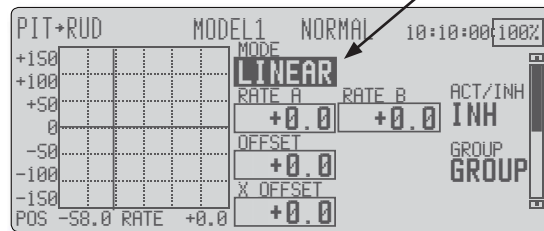

- Normally, use [Line] type.

[Cursor Lever]

- Movement on the screen (4 directions)
- Push the lever to call next page.

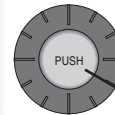

[Data Input Dial]

[Enter Button]

Setting method

- When using this function, move the cursor to the [ACT] item and turn the data input dial to the left and push the enter button. (ON or OFF is displayed.)
- When you want to set the same contents at other conditions, select the group model (Group).
When you want to set the selected condition only, select the single mode (Single).
- A mixing curve is set.

(Currently selected condition name)

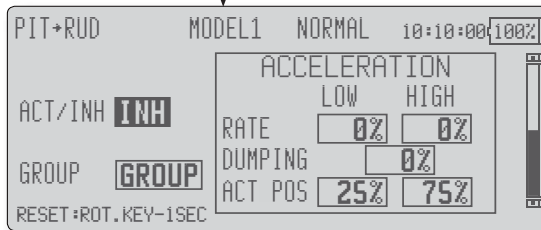

<Normal condition mixing curve>

The mixing curve rate starts from a small value.

For a rotor with a clockwise operation direction (polarity), when pitch was operated at the plus side, set so that mixing is in the clockwise direction. First, trim at hovering and then adjust the neutral position.

1. Adjustment between slow and hovering
Repeatedly hover from take off and land from hovering at a constant rate matched to your own rhythm, and adjust the pitch so the nose does not deflect when the throttle is raised and lowered.
2. Throttle high side (climbing and diving from hovering)

*Repeat climbing and diving from hovering at a constant rate matched to your own rhythm and adjust the pitch so that the nose does not deflect when the throttle is raised and lowered.

<Idle up condition mixing curve>

Set the mixing rate so that the rudder direction at high-speed flight is straight ahead. Adjust for each condition used.

<Acceleration function setting>

- Acceleration operation can be performed for both setting at acceleration (High) and setting at deceleration (Low).
- Acceleration rate setting (Rate)
- The return time after operation (Dump.) can be set.
- An operation point (Act Pos) at acceleration and deceleration can be set independently. When an operation point was exceeded, acceleration operation is performed.

GYRO mixing

This function used to adjust gyro sensitivity. The sensitivity and operation mode (Normal mode/GY mode) can be set for each condition.

*Sensitivity setting is assigned to CH3.

Note: Always set to [NULL] both (Control) and (Trim) for the [Gyro] function at the Function menu of the Linkage Menu.

Setting example

- Normally, it is convenient to preset high sensitivity (Rate 1) and low sensitivity (Rate 2) when either the AVCS mode or Normal mode is used.

- Select [GYRO] at the model menu and call the setup screen shown below by pushing the enter button.

[Return Key]
 • To home screen

• To preceding screen

The screenshot shows the GYRO setup screen for MODEL1 in NORMAL mode. The screen displays the following settings:

GYRO	MODEL1	NORMAL	10:10:00	100%
RATE 1 ²³	RATE1	MODE	RATE	
ACT	ON	AVCS	0%	(0%)
TYPE	GY	FINE TUNING		
SWITCH	NULL	CTRL	RATE	
GROUP	GRP	NULL +	0%	(+0%)

Annotations and controls:

- (Currently selected condition name)**: Points to MODEL1.
- [Cursor Lever]**: A lever with four directional arrows (up, down, left, right) for movement on the screen.
 - Movement on the screen (4 directions)
 - Push the lever to call next page.
- [Data Input Dial]**: A circular dial with a 'PUSH' button in the center.
- [Enter Button]**: Points to the 'PUSH' button on the dial.

Setting method

- When using this function, move the cursor to the [ACT] item and turn the data input dial to the left and push the enter button. (ON or OFF is displayed.)
- When you want to set the same contents at other conditions, select the group model (Group).
 When you want to set the selected condition only, select the single mode (Single).
- Three rates can be switched for each condition. (Rate 1/Rate 2/Rate 3)
- A fine tuning VR can be set.

GOVERNOR mixing

This is used to switch the RPM of the helicopters head. Up to 3 rates can be set for each condition.

- *The governor is used by connecting the governor speed setting channel to CH7 (initial setting).
- *When using an independent governor [ON]/[OFF] switch, connect the AUX([ON]/[OFF]) connector of the governor to CH8 (initial setting) and set the switch to CH8 (Governor2) at the Function menu of the Linkage Menu.

*When using the Fuel Mixture function, the mixture servo is controlled from the governor. When transmitting the mixture curve data from the transmitter to the governor, the governor AUX (m.trm) connector must be connected to CH8 (initial setting) and governor side setting performed. See the governor instruction manual.

Note: Always set (Control) and (Trim) to [NULL] for [Governor] and [Governor 2] of the Function menu of the Linkage menu.

- Select [GOVERNOR] at the model menu and call the setup screen shown below by pushing the enter button.

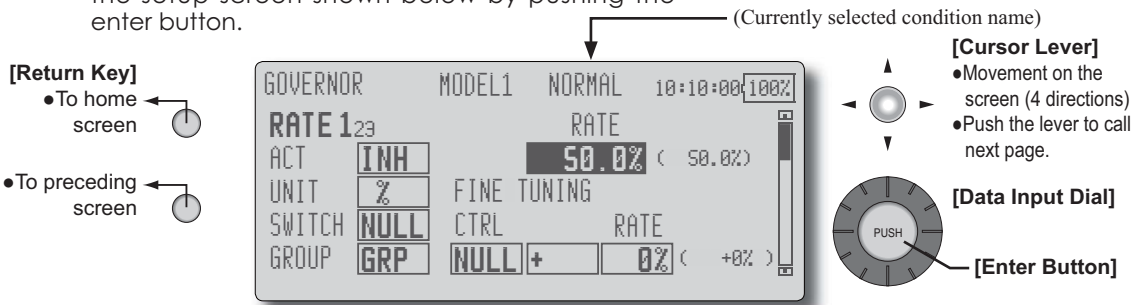

- Governor Seed adjustment

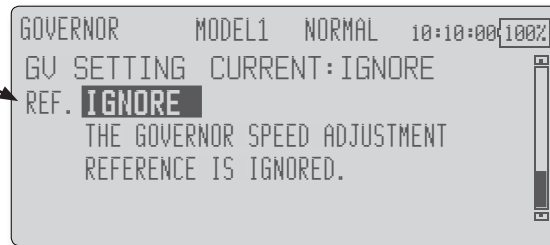

Setting method

- When using this function, move the cursor to the [ACT] item and turn the data input dial to the left and push the enter button. (ON or OFF is displayed.)
- When you want to set the same contents at other conditions, select the group model (Group).
When you want to set the selected condition only, select the single mode (Single).
- Three speeds (rates) can be set for each condition. (Rate 1/Rate 2/Rate 3)
Also, this mixing and the governor side speed setting must be matched beforehand by the following method:
- Set so that when the governor side is placed in the speed setting item state. And Move the cursor to REF item in the GV Setting screen and rotate the data input dial to display [2000rpm] and push the enter button and then set the governor speed to "2000". When [1500rpm], set it to "1500". When [1000rpm], set it to "1000".
- When you want to read the speed directly, move the cursor to Unit item and turn the data input dial to the left and push the enter button. ([rpm] is displayed.)
- The speed can be switched by setting a switch. Also, when [NULL] is set instead of speed setting, the governor can be turned [ON]/[OFF] without setting a separate [ON]/[OFF] switch.
- A speed fine tuning VR can be set.
*VR selection, adjustment width, and adjustment direction can be set.

Common operations used in function setup screen

This section describes the functions often used at the function setup screen. Refer to it when setting each function.

Operations related to flight conditions

Group/single mode switching (GROUP/SINGLE)

When setting multiple flight conditions, linking the setting contents with other conditions (group mode) or setting independently (single mode) can be selected. The mode can be changed at the [GROUP] item on each setup screen.

[Group/single mode switching]



1. Use the cursor lever to move the cursor (reverse-video) to the [GROUP] item on the setup screen.

2. Turn the data input dial to the left until switch [SINGLE] starts to blink.

*At this point, the mode has still not been changed.

*When changing from [SINGLE] to [GROUP], turn the data input dial to the right.

3. Change the mode by pushing the enter key.

● Group mode (GROUP) (Initial setting)

The same setting contents are set to all the flight conditions in the group mode.

● Single mode (SINGLE)

Set this mode when the setting contents are not linked with other conditions.

● Selecting the single mode at each condition after presetting in the group mode is convenient.

Condition delay setting

Unnecessary fuselage motion generated when there are sudden changes in the servo position and variations in the operating time between channels can be suppressed by using the condition delay function of the condition select function [CONIT. SELECT].

When the delay function is set at the switching destination condition, a delay corresponding to that amount is applied and the related functions change smoothly.

[Setting method]



*At the condition delay setup screen, move the cursor (blinking) to the [DELAY] item of the channel you want to set and perform the following settings:

1. Switch to the condition you want to set.

2. Set the delay.

Initial value: 0

Adjustment range: 0~27 (maximum delay)

(When the enter button is pushed for 1 second, the delay is reset to the initial value.)

Operations related to fine tuning VR

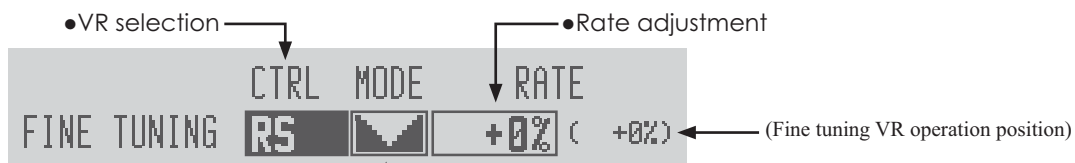

● Operation mode selection

*The operation modes which can be selected depend on the function.

*When the mode is displayed by an icon, read the description at the right.

[Operation mode]



Mixing rate 0% at center of VR. When the VR is turned clockwise and counterclockwise, the mixing rate increases and decreases, respectively.



Mixing rate 0% at left end of VR. When the VR is turned, the mixing rate increases.



Mixing rate 0% at right end of VR. When the VR is turned, the mixing rate increases.



When the VR is turned to the left or right of the neutral position, the mixing rate increases.

Operations related to servo speed

Servo speed setting (1)

The servo speed at each function operation (including flight condition switching) can be adjusted. The servos operate smoothly at a fixed speed corresponding to the set speed. The operating speed (IN side) and return speed (OUT side) can be set individually.

Switch the operation mode according to the set function.

"SYMMET" mode: Mode used with ailerons and other self neutral functions.

"LINEAR" mode: Mode used with functions which hold the operation position of the throttle and switch channel, etc.

[Setting method]



1. Use the cursor lever to move the cursor (reverse-video) to the [MODE] item.
2. Turn the data input dial to the left or right and switch to the operation mode ("SYMMET" or "LINEAR") corresponding to the set function.
3. Move the cursor to the direction ([IN] or [OUT]) side you want to set.
4. Turn the data input dial to the left or right and set the speed.

Initial value: 0

Adjustment range: 0~27 (maximum delay)

(When the enter button is pushed for 1 second, the servo speed is reset to the initial value.)

Servo speed setting (2)

(Program mixing)

The operation start point at operation (IN side) and return (OUT side) can also be set by servo speed setting (1) function.

[Setting method]

*Perform the [SPEED] item the same as [Servo speed setting (1)]. Set [DELAY] (operation start point) by the following method:



1. Use the cursor lever to move the cursor (reverse-video) to the [START] item.
2. Turn the data input dial to the left or right and set the delay from switch ON to the start of function operation.
Initial value: 0.0sec
Setting range: 0 to 9 sec
(When the enter button is pushed for 1 second, the servo speed and delay are reset to the initial values.)
3. Use the cursor lever to move the cursor (reverse-video) to the [STOP] item.
4. Turn the data input dial to the left or right and set the delay time from switch OFF to the start of function operation.
Initial value: 0.0 sec
Setting range: 0 to 9 sec
(When the enter button is pushed for 1 second, the servo speed and delay are reset to the initial values.)

Curve setting operation

This section describes the setting procedure of curves which are used with the AFR function and each mixing function.

Curve type selection

Six types of curves (linear, EXP1, EXP2, VTR, line and spline) can be selected.

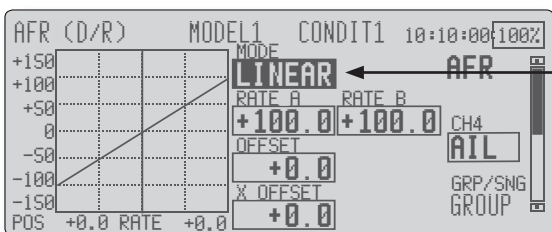

Note: When you change the curve type, the preset curve data in the function is cleared. Be sure that you don't mind losing this data.

Curve type selection

1. Use the cursor lever to move the cursor (reverse-video) to the [MODE] item.
2. Display the curve you want to use by turning the data input dial to the left or right.
 - *The curve type blinks.
3. When the enter button is pushed, the curve type is changed. (Operate another key to stop the change.)

[LINEAR]: Linear curve
 [EXP1]: EXP1 curve
 [EXP2]: EXP2 curve
 [VTR1]: VTR1 curve
 [LINE]: Line
 [SPLINE]: Spline

Setting by curve type

When the curve type is selected as described above, adjustment items corresponding to the curve type appear on the screen. Adjust each curve as described below.

Linear curve (LINEAR) adjustment

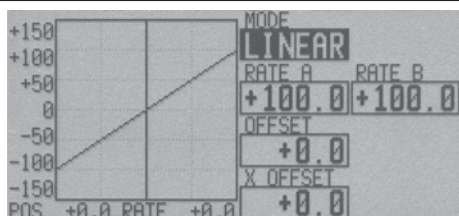

The curve left and right rates ([RATE A], [RATE B]) can be adjusted separately.

The curve can also be offset horizontally ([OFFSET]) in the vertical direction and the rate reference point can be offset ([X OFFSET]) to the left and right.

[Rate setting]

1. Use the cursor lever to move the cursor (reverse-video) to the [RATE A] or [RATE B] setting item.
2. Set the rate by turning the data input dial to the left or right.

Initial value: +100.0%

Adjustment range: -200.0~+200.0%

(When the enter button is pressed for 1 second, the rate is reset to the initial value.)

[Offsetting the curve horizontally in the vertical direction]

1. Use the cursor lever to move the cursor (reverse-video) to the [OFFSET] setting item.
2. Move the curve in the vertical direction by turning the data input dial to the left or right.

Initial value: +0.0%

(When the enter button is pressed for 1 second, the curve is reset to the initial value.)

[Offsetting the rate reference point to the left or right]

1. Use the cursor lever to move the cursor (reverse-video) to the [X OFFSET] setting item.
2. Offset the curve reference point to the left or right by turning the data input dial to the left or right.

Initial value: +0.0%

(When the enter button is pressed for 1 second, the reference point is reset to the initial value.)

EXP1/EXP2 curve adjustment

(EXP1 curve)

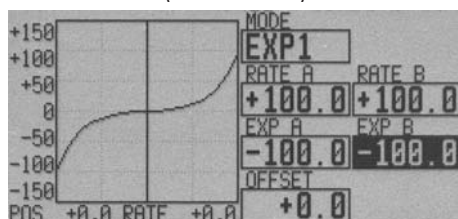

Using the EXP1 curve is effective in smoothing starting of the ailerons, elevator, rudder, etc.

(EXP2 curve)

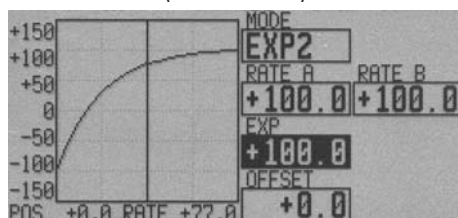

Using the EXP2 curve is effective in engine rise and other engine control.

The curve left and right rates ([RATE A], [RATE B]) and EXP curve rate ([EXP A], [EXP B]) can be adjusted individually. ([EXP] for EXP2)

The curve can also be offset horizontally ([OFFSET]) in the vertical direction.

[Rate setting]

1. Use the cursor lever to move the cursor (reverse-video) to the [RATE A], [RATE B], [EXP A], or [EXP B] setting item.
2. Set the rate by turning the data input dial to the left or right.

Initial value: +100.0% (rate)/+0.0% (EXP rate)

Adjustment range: -200.0~+200.0% (rate)/-100.0~+100.0% (EXP rate)

(When the enter button is pushed for 1 second, the rate is reset to the initial value.)

[Offsetting the curve horizontally in the vertical direction]

1. Use the cursor lever to move the cursor (reverse-video) to the [OFFSET] setting item.
2. Move the curve in the vertical direction by turning the data input dial to the left or right.

Initial value: +0.0%

VTR curve adjustment

(VTR curve)

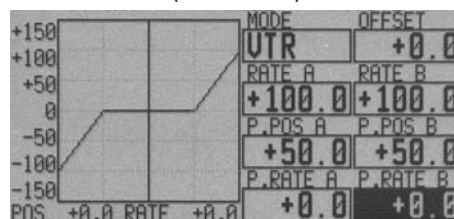

When this curve is used, when the operating rudder angle is large such as with acrobatic models, switching from normal flight to acrobatic rudder angle is performed without switch operation.

The curve left and right rates ([RATE A], [RATE B]) can be adjusted individually. The curve can also be offset horizontally ([OFFSET]) in the vertical direction.

The VTR curve point position ([P.POS A], [P.POS B], and rate ([P.RATE A], [P.RATE B]) can be adjusted individually.

[Rate setting]

1. Use the cursor lever to move the cursor (reverse-video) to the [RATE A] or [RATE B] setting item.
2. Set the rate by turning the data input dial to the left or right.

Initial value: +100.0%

Adjustment range: -200.0~+200.0%

(When the enter button is pushed for 1 second, the rate is reset to the initial value.)

[VTR curve point setting]

1. Use the cursor lever to move the cursor (reverse-video) to the [P.POS A], [P.POS B], [P.RATE A], or [P.RATE B] setting item.
2. Set the rate by turning the data input dial to the left or right.

Initial value: +50% ([P.POS A], [P.POS B])/+100.0% ([P.RATE A], [P.RATE B])

Adjustment range: +0.0~+100.0%

(When the enter button is pressed for 1 second, the rate is reset to the initial value.)

*When [P.POS A] or [P.POS B] is made large, the curve point moves to the outside. When [P.RATE A] or [P.RATE B] is set to +100%, the curve becomes a straight line.

[Offsetting the curve horizontally in the vertical direction]

1. Use the cursor lever to move the cursor (reverse-video) to the [OFFSET] setting item.
 2. Move the curve in the vertical direction by turning the data input dial to the left or right.
- Initial value: +0.0%

Line (LINE) and curve (SPLINE) adjustment

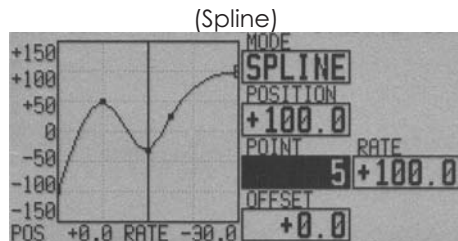
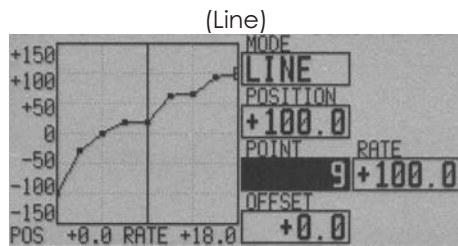

Lines or splines of up to 17 points can be used. (Initial value: 9 points) The set points can be freely increased, decreased, and offset.

[Rate adjustment of each point]

1. Use the cursor lever to move the cursor (reverse-display) to the [POINT] item and turn the data input dial to the left or right and select the point whose rate you want to set. (The position of the square box on the curve is the selected point.)
2. Move the cursor to the [RATE] item and set the rate by turning the data input dial to the left or right.

[Point addition]

1. Use the cursor lever to move the cursor to the [POSITION] item and turn the data input dial to the left or right and move the square box to the position you want to add.
2. When the enter button is pushed for 1 second, the selected point is added.

[Point deletion]

1. Use the cursor lever to move the cursor to the [POINT] item and turn the data input dial to the left or right and select the point you want to delete.
2. When the enter button is pushed for 1 second, the selected point is deleted.

[Offsetting the curve horizontally in the vertical direction]

1. Use the cursor lever to move the cursor (reverse-video) to the [OFFSET] setting item.
2. Move the curve in the vertical direction by turning the data input dial to the left or right.
Initial value: +0.0%

(When the enter button is pushed for 1 second, the curve is reset to the initial value.)

Switch selection method

The various functions used in the T12Z can be selected by switch. The switch (including when stick, trim lever, or VR are used as a switch) setting method is common to all functions.

Switch selection

When a switch is selected at a mixing function, etc., the selection screen shown below is called.

(Switch selection screen example)

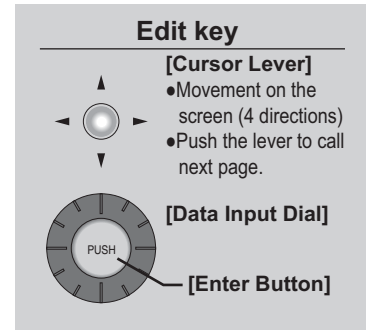
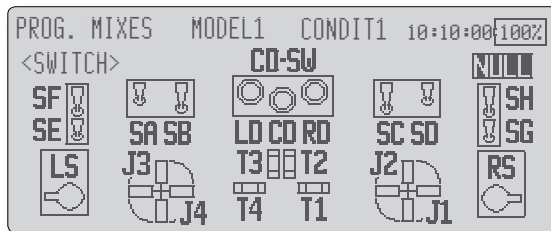

When switch was selected

When switch was selected, ON/OFF position setting is also performed.

1. Use the cursor lever to move the cursor (reverse-video) to the switch you want to select and push the enter button. The switch is selected and the ON/OFF position setup screen shown below is displayed.

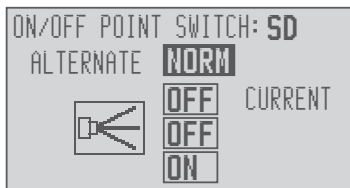

*The ON/OFF setting state of each position is displayed.

2. When you want to change the ON/OFF setting, use the cursor lever to move the cursor (reverse-video) and switch the ON/Off display by turning the data input dial to the left or right.
- *ON/OFF display blinks.
3. When the enter button is pressed, the ON/OFF setting is changed. (Operate another key to stop the change.)
4. Return to the original screen by return key.

When stick, trim lever, or knob selected

When a stick, trim lever, or knob is used as a switch, four operation modes can be selected by the following mode and type combination:

- Mode: [LINEAR] (Linear)/[SYMMET] (symmetrical)
 - Type: [HYSTER] (hysteresis)/[BOX]: (box)
1. Use the cursor lever to move the cursor (reverse-video) to the stick, trim lever, or knob you want to select and push the enter button. The stick, trim lever, or knob is selected as a switch and the ON/OFF position setup screen shown below is displayed.

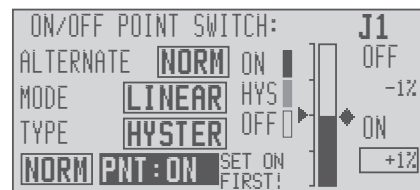

2. When you want to change the mode or type, move the cursor to [MODE] or [TYPE] and switch the display to the mode or type you want to change by turning the data input dial to the left or right and then make the change by pushing the enter button.

*Set the ON/Off point by the method described on the next page.

Operation modes

The operation modes when stick, trim lever, or knob was selected are described below.

*When the enter button is pushed after the cursor was moved to the [MODE] and [TYPE] items and the mode was selected by data input dial, the operation mode is changed.

Linear hysteresis mode

This mode sets ON/OFF at the left or right (up or down) with the set point as the reference. Hysteresis (dead band) can be set between ON and OFF. The ON and OFF positions can be reversed.

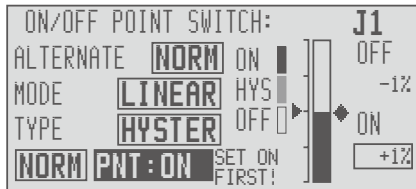

Linear box mode

This mode turns on the switch within a range of 2 points. Each point can be set. The ON and OFF positions can be reversed.

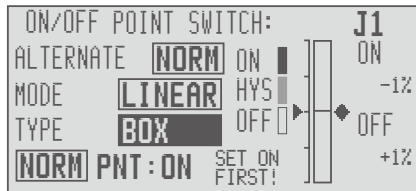

Symmetrical hysteresis mode

Operation is the same as the linear hysteresis mode, but left and right (up and down) operations are symmetrical about the neutral position. For instance, when you want to switch DR1 with the aileron stick, when the stick is moved to the left or right, DR1 can be turned on at the same left and right position.

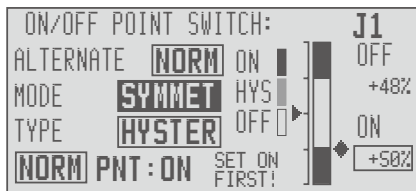

Symmetrical box mode

Operation is the same as the linear box mode, but left and right (up and down) operation is symmetrical about the neutral position.

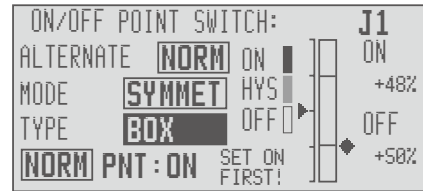

Shifting the ON/Off point

The ON/OFF and hysteresis (dead band) boundary point can be shifted. ON/OFF at a free position and the hysteresis width can be changed.

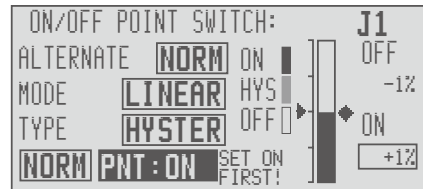

- Black range: ON range
- Grey range: Hysteresis (dead band) range
- White range: OFF range

[Setting method]

1. First, use the cursor lever to move the cursor (reverse-video) to the [PNT:] item.
2. When the data input dial is turned to the left, the ON side point can be set and when the data input dial is turned to the right, the OFF side point can be set.
3. Move the stick, trim lever, or knob to the point you want to change and push the enter button. The point is shifted.

A hysteresis range can be created by the ON side and OFF side point setting described above.

Updating

The T12Z transmitter program can be updated. When functions are added or improved, the update file can be downloaded from Futaba dealer web site. Copy the update files to the CF card and then use the following procedure to update the program.

Updating procedure

Note: If the battery fully discharges during program updating, updating will fail. When the remaining battery capacity is 50% or less, always recharge the battery before updating.

Note: The model data in the transmitter can be used unchanged after updating, but to be safe, back up the model data before updating.

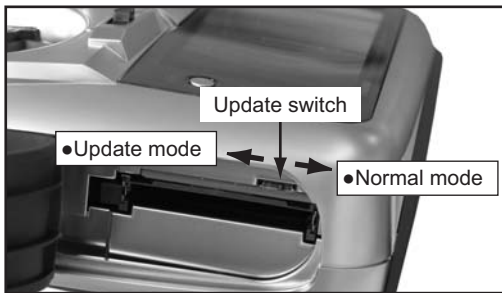

1. Insert the CF card containing the update file into the card slot.
2. Use tweezers to switch the slide switch (update switch) at the side of the card slot in the up direction.
3. Turn on the transmitter power. About 10 seconds later, the screen shown below will appear. (To abort updating, turn off the transmitter power.)



*If a CF card is not inserted into the card slot, or the files needed at updating are not copied to the CF card, the error message shown below will appear. Turn off the power to the transmitter and check the CF card.

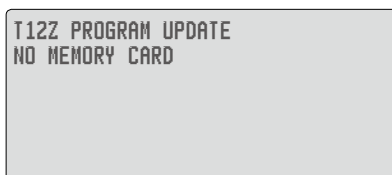

4. When the enter button is pushed about 3 seconds, updating starts.

During writing, the bar graph moves to the right.

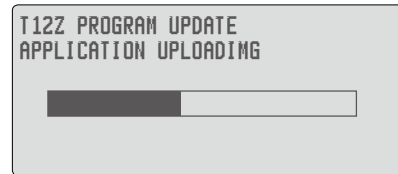

5. When updating is complete, the screen shown below appears.

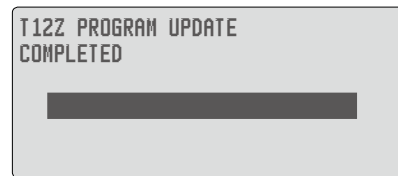

6. Turn off the power switch. After the monitor LED goes off, switch the update switch in the down direction.

*After the updating above has been completed, turn on the power and then check the system program version at the system menu information screen.