

Thank you for purchasing a Futaba 4PK-2.4GHz system.
Before using your 4PK-2.4GHz system, read this manual carefully in order to use
your R/C set safely.
After reading this manual, store it in a safe place.

Application, Export, and Modification

1. This product may be used for models only. It is not intended for use in any application other than the control of models for hobby and recreational purposes.

2. Exportation precautions:
 - (a) When this product is exported from the country of manufacture, its use is to be approved by the laws governing the country of destination for devices that emit radio frequencies. If this product is then re-exported to other countries, it may be subject to restrictions on such export. Prior approval of the appropriate government authorities may be required. If you have purchased this product from an exporter outside your country, and not the authorized Futaba distributor in your country, please contact the seller immediately to determine if such export regulations have been met.
 - (b) Use of this product with other than models may be restricted by Export and Trade Control Regulations, and an application for export approval must be submitted.

3. Modification, adjustment, and replacement of parts: Futaba is not responsible for unauthorized modification, adjustment, and replacement of parts on this product. Any such changes may void the warranty.

Compliance Information Statement (for U.S.A.)

This device, trade name Futaba Corporation of America, model number R604FS, complies with part 15 of the FCC Rules. Operation is subject to the following two conditions:

- (1) This device may not cause harmful interference.
- (2) This device must accept any interference received, including interference that may cause undesired operation.

The responsible party of this device compliance is:

Futaba Service Center

3002 N Apollo Drive Suite 1, Champaign, IL 61822 U.S.A.

TEL (217)398-8970 or E-mail: support@futaba-rc.com (Support)

TEL (217)398-0007 or E-mail: service@futaba-rc.com (Service)

Battery Recycling (for U.S.A.)



The RBRC™ SEAL on the (easily removable) nickel-cadmium battery and nickel-metal-hydride battery contained in Futaba products indicates that Futaba Corporation of America is voluntarily participating in an industry program to collect and recycle these batteries at the end of their useful lives, when taken out of service within the United States. The

RBRC™ program provides a convenient alternative to placing used nickel-cadmium batteries and nickel-metal-hydride batteries into the trash or municipal waste system, which is illegal in some areas.

You may contact your local recycling center for information on where to return the spent battery. Please call 1-800-8-BATTERY for information on Ni-Cd / Mi-MH battery recycling in your area. Futaba Corporation of America's involvement in this program is part of its commitment to protecting our environment and conserving natural resources.

NOTE: Our instruction manuals encourage our customers to return spent batteries to a local recycling center in order to keep a healthy environment.

RBRC™ is a trademark of the Rechargeable Battery Recycling Corporation.

-
- No part of this manual may be reproduced in any form without prior permission.
 - The contents of this manual are subject to change without prior notice.
 - This manual has been carefully written. Please write to Futaba if you feel that any corrections or clarifications should be made.
 - Futaba is not responsible for the use of this product.



Table Of Contents

For Your Safety As Well As That Of Others.....8

Explanation of Symbols.....	8
2.4GHz System Precautions.....	8
High Speed Mode Precautions.....	8
Operation Precautions.....	9
Ni-MH/Ni-Cd Battery Handling Precautions.....	10
Storage and Disposal Precautions.....	11
Other Precautions.....	11

Before Using12

Features.....	12
Set Contents.....	14
TransmitterT4PK.....	15
T4PK Nomenclature.....	15
Power & Display Switch.....	16
Power Off Forgotten Alarm.....	16
High Voltage Alarm.....	16
Low Battery Alarm.....	16
Digital Trim Operation.....	17
Grip Dial Operation.....	17
Mechanical ATL Adjustment.....	18
Wheel & Trigger Tension Adjustment.....	18
Trigger Slide Adjustment.....	19
Ni-MH Battery Replacement.....	19
Charging The HT5F1700B Battery.....	20
Grip Vibrator.....	21
Display when power switch turned on.....	21
Edit button lock and trim/dial lock.....	22
Total Timer.....	22
LCD Screen Contrast.....	22
Changing wheel position and modifying for left-hand use.....	23
Installing the accessory Hook.....	27
About Transmitter Antenna and Receiver.....	28
About Transmitter Antenna.....	28
Receiver Nomenclature.....	28
How to link the transmitter and the receiver.....	29
Receiver Installation.....	29

Installation31

Receiver and Servo Connections.....	31
Installation Safety Precautions.....	32

Initial Set-Up35

Preparations (Transmitter).....35

Function Map38

Menu Selection38

Function Menu Screen38

Menu Screen39

Custom Menu40

Direct Selection42

List of functions by menu type44

Functions List45

Functions46

Receiver Type/Servo Response Mode "RXSYS".....46

Receiver type (C1/C2), Servo response (HIGH/NORMAL) select

Servo Reverse "REV"47

Servo operation reversing

Subtrim "SUBTR"48

Servo center position fine adjustment

End Point Adjuster "EPA"49

End point adjustment

Throttle Acceleration "ACCEL"52

Function which adjusts the movement characteristic from the throttle neutral position

Fail Safe/Battery Fail Safe Function "F/S"54

Fail safe, battery fail safe

Steering Exponential "STEXP"56

Steering operation curve adjustment

Throttle Exponential "THEXP"57

Throttle curve adjustment

Steering Speed "STSPD"61

Steering servo delay

Throttle Speed "THSPD"63

Throttle servo delay

Start Function / Engine Cut "START"66

Throttle preset at start function/ engine cut off by switch

A.B.S. Function "A.B.S"69

Pulse brake

Brake Mixing "BRAKE"74

Front and rear independent brake control for 1/5GP car, etc.

**For Your Safty
As Well As
That Of Others**

**Before
Using**

Installation

**Initial
Set-Up**

**Function
Map**

Functions

Reference

Boat Mode "BOAT"	78
Boat, etc. brake operation stop/outboard engine tilt mixing	
Throttle Mode "THMOD"	80
Neutral brake function	
Throttle servo forward and brake operation proportion setting	
Idle-Up "IDLUP"	82
Idle up at engine start	
Programmable Mixes 1/2 "PMIX1,2"	83
Programmable mixes between arbitrary channels	
Function Select Switch "SWTCH"	86
Selection of functions operated by push switches	
Function Select Dial "DIAL"	88
Selection of functions operated by digital dial and digital trim	
Timer Function "TIMER"	90
Up, Fuel down, lap, or lap navigation timer	
Lap List "LAP-L"	97
Lap timer data (lap time, average lap time) check	
Model Select "M-SEL"	98
Model memory call	
Model Name "NAME"	99
Model memory name set/modify, username set/modify	
Model Copy "M-COP"	100
Model memory copy	
Model Reset "M-RES"	102
Model memory reset	
Menu Type Select	103
Function menu type selection	
ESC Link Function "MCLNK"	104
Special function, Futaba ESC (MC850C, MC601C, MC401CR)	
System Functions "SYSTEM"	108
Battery type setting	
Liquid crystal screen backlighting display mode setup	
Setting of ON time	
Liquid crystal screen contrast adjustment	
Buzzer sound tone adjustment	
Pilot lamp display color setup	
Initial screen display mode setting	
Second condition setting	
The power off forgotten alarm setting	
2.4GHz band setting	
About Second condition function	

Data Transfer "DTTRN"	112
The T4PK model memory data to another T4PK	
Adjuster "ADJST"	114
Steering wheel and throttle trigger correction	
Vibrator Function "VIBRA"	116
Vibrator setting	
Steerind Dual Rate "D/R"	117
Steering angle adjustment while running (dual rate)	
ATL Function "ATL"	118
Brake side adjustment	
Channel 3/4 Position "CH3", "CH4"	119
Channel 3/4 servo operation position set/check	
Servo View "SERVO"	120
Displays servo operation on a bar graph	
Reference	121
<hr/>	
Ratings	121
Optional Parts	122
Warning Displays	124
When requesting repair (For U.S.A.).....	126

**For Your Safty
As Well As
That Of Others**

**Before
Using**

Installation

**Initial
Set-Up**

**Function
Map**

Functions

Reference



For Your Safety As Well As That Of Others

Use this product in a safe manner. Please observe the following safety precautions at all times.

Explanation of Symbols

The parts of this manual indicated by the following symbols are extremely important and must be observed.

Symbols	Explanation
Danger	Indicates a procedure which could lead to a dangerous situation and may cause death or serious injury if ignored and not performed properly.
Warning	Indicates procedures which may lead to dangerous situations and could cause death or serious injury as well as superficial injury and physical damage.
Caution	Indicates procedures that may not cause serious injury, but could lead to physical damage.

Symbols: : Prohibited : Mandatory

2.4GHz System Precautions

Warning

Special attention should be paid before turning on the system while other cars are running or other airplanes are flying because the 2.4GHz RC system could potentially affect them.

Be sure to set the Fail Safe function.

High Speed Mode Precautions

Caution

When using the T4PK in the high speed (HIGH SPEED) mode, always use it under the following conditions:

Servos	:6V Futaba digital servo (including BLS Series brushless servos)
Receiver's battery	:6V Ni-Cd battery
Transmitter mode	:HIGH SPEED mode (See p.46 for setting method.)

Under other conditions, the set will not operate, or the specified performance will not be displayed even if it operates. In addition, it may cause servo trouble. Futaba will not be responsible for damage, etc. caused by combination with the products of other companies.

In addition, the FSU1 Fail Safe Unit cannot be used because the system is different. Use the fail safe function of the transmitter.

When using analog servos, always switch the T4PK servo response to the NORMAL mode.

Transmitter mode	:NORMAL mode (See p.46 for setting method.)
Receiver's battery	:6V Ni-Cd battery

The set cannot operate in the HIGH SPEED mode. Operation in this mode will cause trouble of servo and other equipments. Digital servos (including BLS Series brushless servos) can also be used in the NORMAL mode.

Operation Precautions

Warning

 Do not operate outdoors on rainy days, run through puddles of water or use when visibility is limited. Should any type of moisture (water or snow) enter any component of the system, erratic operation and loss of control may occur.

 Do not operate in the following places.

- Near other sites where other radio control activity may occur.
- Near people or roads.
- On any pond when row boats are present.
- Near high tension power lines or communication broadcasting antennas.

Interference could cause loss of control. Improper installation of your Radio Control System in your model could result in serious injury.

 Do not operate this R/C system when you are tired, not feeling well or under the influence of alcohol or drugs.

Your judgment is impaired and could result in a dangerous situation that may cause serious injury to yourself as well as others.

 Extend the transmitter antenna to its full length.

If the transmitter antenna is not fully extended, the operating range of the radio will be reduced.

 Always perform a operating range check prior to use.

Problems with the radio control system as well as improper installation in a model could cause loss of control. (Simple range test method)

Have a friend hold the model, or clamp it down or place it where the wheels or prop cannot come in contact with any object. Walk away and check to see if the servos follow the movement of the controls on the transmitter. Should you notice any abnormal operation, do not operate the model. Also check to be sure the model memory matches the model in use.

 Check the transmitter antenna to be sure it is not loose.

If the transmitter antenna works loose, or is disconnected while the model is running, signal transmission will be lost. This will cause you to lose control of the model. Rotate the antenna softly with your fingers when checking whether it is loosely or firmly fixed. Do not screw the antenna forcibly. Otherwise its antenna-holding part can be damaged.

Caution

 Do not touch the engine, motor, speed control or any part of the model that will generate heat while the model is operating or immediately after its use.

These parts may be very hot and can cause serious burns.

 Turning on the power switches.

Always check the throttle trigger on the transmitter to be sure it is at the neutral position.

1. Turn on the transmitter power switch.
2. Turn on the receiver or speed control power switch.

Turning off the power switches

Always be sure the engine is not running or the motor is stopped.

1. Turn off the receiver or speed control power switch.
2. Then turn off the transmitter power switch.

If the power switches are turned off in the opposite order, the model may unexpectedly run out of control and cause a very dangerous situation.

ⓘ When making adjustments to the model, do so with the engine not running or the motor disconnected.
 You may unexpectedly lose control and create a dangerous situation.

(Fail safe function)

ⓘ Before running (cruising), check the fail safe function.
 Check Method; Before starting the engine, check the fail safe function as follows:

- 1) Turn on the transmitter and receiver power switches.
- 2) Wait at least one minute, then turn off the transmitter power switch. (The transmitter automatically transfers the fail safe data to the receiver every minute.)
- 3) Check if the fail safe function moves the servos to the preset position when reception fails.
 The fail safe function is a safety feature that minimizes set damage by moving the servos to a preset position when reception fails. However, if set to a dangerous position, it has the opposite effect. When the reverse function was used to change the operating direction of a servo, the fail safe function must be reset.
 Setting example: Throttle idle or brake position

Ni-MH / Ni-Cd Battery Handling Precautions

(Only when Ni-MH/Ni-Cd batteries are used)

⚠ Warning

⊘ Never plug the charger into an outlet other than indicated voltage.
 Plugging the charger into the wrong outlet may result in an explosion, sparking, or fire.

⊘ Never insert or remove the charger while your hands are wet.
 You may get an electric shock.

⊘ Do not use the transmitter's battery, HT5F1700B, as the receiver's battery.
 Since the transmitter's battery has an overload protection circuit, the output power will be shut down when the high current load is applied. This may result in run-a-way or fatal crash.

ⓘ Always check to be sure your batteries have been charged prior to operating the model.
 Should the battery go dead while the model is operating, loss of control will occur and create a very dangerous situation.

ⓘ To recharge the transmitter battery, use the special charger made for this purpose.
 Overcharging could cause the battery to overheat, leak or explode. This may lead to fire, burns, loss of sight and many other types of injuries.

⚠ Caution

⊘ Do not use commercial AA size Ni-Cd and Ni-MH batteries.
 Quick charging may cause the battery contacts to overheat and damage the battery holder.

⊘ Do not short circuit the battery terminals.
 A short circuit across the battery terminals may cause abnormal heating, fire and burns.

⊘ Do not drop the battery or expose it to strong shocks or vibrations.
 The battery may short circuit and overheat; electrolyte may leak out and cause burns or chemical damage.

ⓘ When the model is not being used, always remove or disconnect the battery.
 Leaving the battery connected could create a dangerous situation if someone accidentally turns on the receiver power switch. Loss of control could occur.

❗ Always keep the charger disconnected from the outlet while it is not in use.

Storage and Disposal Precautions

⚠ Warning

⊘ Do not leave the radio system or models within the reach of small children.

A small child may accidentally operate the system. This could cause a dangerous situation and injuries. Ni-Cd batteries can be very dangerous when mishandled and cause chemical damage.

⊘ Do not throw Ni-MH/Mi-Cd batteries into a fire. Do not expose batteries to extreme heat. Also do not disassemble or modify a battery pack.

Overheating and breakage will cause the electrolyte to leak from the cells and cause skin burns, loss of sight, and other injuries.

❗ When the system will not be used for any length of time, store the system with HT5F1700B batteries in a discharged state. Be sure to recharge the batteries prior to the next time the system is used.

If the batteries are repeatedly recharged in a slightly discharged state, the memory effect of the Ni-Cd battery may considerably reduce the capacity. A reduction in operating time will occur even when the batteries are charged for the recommended time. (After discharge to 1cell E.V.=1V)

<Ni-MH/Ni-Cd Battery Electrolyte>

The electrolyte in Ni-MH/Ni-Cd batteries is a strong alkali. Should you get even the smallest amount of the electrolyte in your eyes, DO NOT RUB, wash immediately with water, and seek medical attention at once. The electrolyte can cause blindness. If electrolyte comes in contact with your skin or clothes, wash with water immediately.

⚠ Warning

⊘ Do not store your R/C system in the following places.

- Where it is extremely hot or cold.
- Where the system will be exposed to direct sunlight.
- Where the humidity is high.
- Where vibration is prevalent.
- Where dust is prevalent.
- Where the system would be exposed to steam and condensation.

Storing your R/C system under adverse conditions could cause deformation and numerous problems with operation.

❗ If the system will not be used for a long period of time, remove the batteries from the transmitter and model and store in a cool, dry place.

If the batteries are left in the transmitter, electrolyte may leak and damage the transmitter. This applies to the model also. Remove the batteries from it also to prevent damage.

<Ni-MH/Ni-Cd Battery Recycling>

A used battery is valuable resource. Insulate the battery terminals and dispose of the battery by taking it to a battery recycling center.

Other Precautions

⚠ Caution

⊘ Do not expose plastic parts to fuel, motor spray, waste oil or exhaust.

The fuel, motor spray, waste oil and exhaust will penetrate and damage the plastic.

❗ Always use only genuine Futaba transmitters, receivers, servos, ESCs (electronic speed controls), Ni-MH/Ni-Cd batteries and other optional accessories.

Futaba will not be responsible for problems caused by the use of other than Futaba genuine parts. Use the parts specified in the instruction manual and catalog.



Before Using

Features

-2.4GHzSS (Spread Spectrum) radio communication system

Frequency channel setting unnecessary: Channel shifting takes place within the 2.4GHz band automatically, this system minimizes the interference from other 2.4GHz systems.

-Model memory for 40 models

Model names can use up to 10 letters, numbers, and symbols, so that logical names may be used. A model memory with different setups can be created by using the model copy function.

-Two function selection modes: Menu Selection and Direct Selection

The setup screens are called from menu screens. The menu screen can be selected from among 4 levels (LEVEL1/LEVEL2/LEVEL3/BIGCAR).

Frequently used (high degree of urgency) functions can be assigned to direct selection buttons which quickly call the assigned function. (8 functions)

-Menu customizing

Function menus can be customized as desired. The menu order, display function and other functions used by individual models only can be displayed.

-Brake mixing for large cars (BRAKE)

Brake mixing of the front and rear wheels of 1/5GP and other large cars can be adjusted independently.

-Anti-skid braking system (A.B.S)

This function applies the brakes so that the tires of gasoline engine cars, etc. do not lose their grip on the road even when braking at corners.

-Throttle acceleration (ACCEL)

Gasoline engine cars have a time lag before the clutch and brakes become effective. The TH-ACCEL function reduces this time lag.

-Throttle speed (THSPD)

Sudden trigger operation on a slippery road surface will only cause the tires to spin and the model to not accelerate smoothly. By setting the throttle speed function, operation can be performed smoothly and easily. It also suppresses battery consumption.

-Start function (START)

A pre-set throttle position, less than full throttle, to be used for the initial acceleration off the line without having wheel spin. When the trigger is released, auto-start is turned off and throttle operates normally again.

-Steering speed (STSPD)

When you sense that the steering servo is too fast, etc., the servo operating speed (direction that suppresses the maximum speed) can be adjusted.

-Racing timer (TIMER)

The lap timer can record 99 lap times, total time, and average lap time. The timer can also be started automatically by trigger operation. The race time and audible alarm can be set.

The 4PK also has a navigation timer effective during practice runs. The target lap and refueling time are indicated by an audible alarm. An up timer and down timer are also provided.

-Digital trim w/reset function

The current trim position is displayed on the LCD screen. The operating amount of 1 step can also be adjusted.

Trim operation has no affect on the maximum travel of the steering and throttle servos.

-Function select dial function (DIAL)

This function assigns functions to dials (digital trim, grip dial, knob). The step amount and operating direction can also be adjusted. Trim positioning at each model call is unnecessary because all the dials are digital.

-Function select switch function (SWTCH)

This function assigns functions to 3 switches. The operating direction can also be set.

-MC-Link

This is a dedicated function which allows setting of the contents of the Link software which makes possible Futaba speed controller (ESC), MC850C, MC601C, MC410CR, etc. variable frequency and other data changes by PC at the T4PK.

-Edit button lock & trim/dial lock functions

Lock functions which prohibit setting and operation by transmitter edit buttons, trim, and dials are provided.

-Wheel & Trigger position can be changed

The wheel position can be offset by using an accessory APA wheel position offset adapter.

The wheel angle can also be adjusted.

The position of the throttle trigger can be moved forward and backward.

-Left-handed support

The left and right installation direction of the wheel section can be reversed.

-Tension adjustment function

The tension of the steering wheel & throttle trigger springs can be adjusted from the outside.

-Mechanical ATL Adjustment

Make this adjustment when you want to decrease the total travel of the brake (push) side of the throttle trigger.

-Display switch

Display switch allows function setup without transmitting.

-Vibrator built into the grip

The vibrator can be operated at racing timer lap navigation, time-up, and low battery alarm.

-7-color LED pilot lamp

Your favorite color can be selected.

Set Contents

After opening the box, first check if the contents conform to the following. The contents depend on the set as shown below.

Before Using

Transmitter	T4PK
Receiver	R604FS
Miscellaneous	<p>Transmitter Ni-MH battery pack HT5F1700B *Installed in transmitter.</p> <p>Receiver switch</p> <p>Wheel offset adapter(APA)</p> <p>Hook</p> <p>Instruction manual</p>

- If any of the set contents are missing, or you have any questions, please contact your dealer.

Caution

- ① When using the T4PK in the high speed (HIGH SPEED) mode, always use it under the following conditions:

Servos	:6V Futaba digital servo (including BLS Series brushless servos)
Receiver's battery	:6V Ni-Cd battery
Transmitter mode	:HIGH SPEED mode (See p.46 for setting method.)

Under other conditions, the set will not operate, or the specified performance will not be displayed even if it operates. In addition, it may cause servo trouble. Futaba will not be responsible for damage, etc. caused by combination with the products of other companies.

In addition, the FSU1 Fail Safe Unit cannot be used because the system is different. Use the fail safe function of the transmitter.

- ① When using analog servos, always switch the T4PK servo response to the NORMAL mode.

Transmitter mode	:NORMAL mode (See p.46 for setting method.)
Receiver's battery	:6V Ni-Cd battery

The set cannot operate in the HIGH SPEED mode. Operation in this mode will cause trouble of servo and other equipments. Digital servos (including BLS Series brushless servos) can also be used in the NORMAL mode.

- ① Always use only genuine Futaba transmitters, receivers, servos, ESCs (electronic speed controls), Ni-MH(Ni-Cd) batteries and other optional accessories.

Futaba will not be responsible for problems caused by the use of other than Futaba genuine parts. Use the parts specified in the instruction manual and catalog.

Transmitter T4PK

Nomenclature

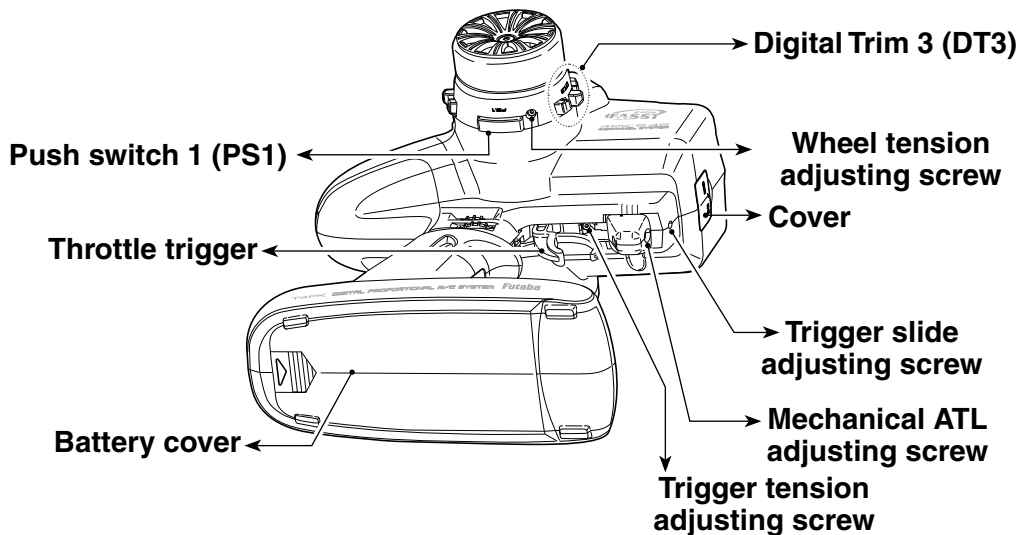
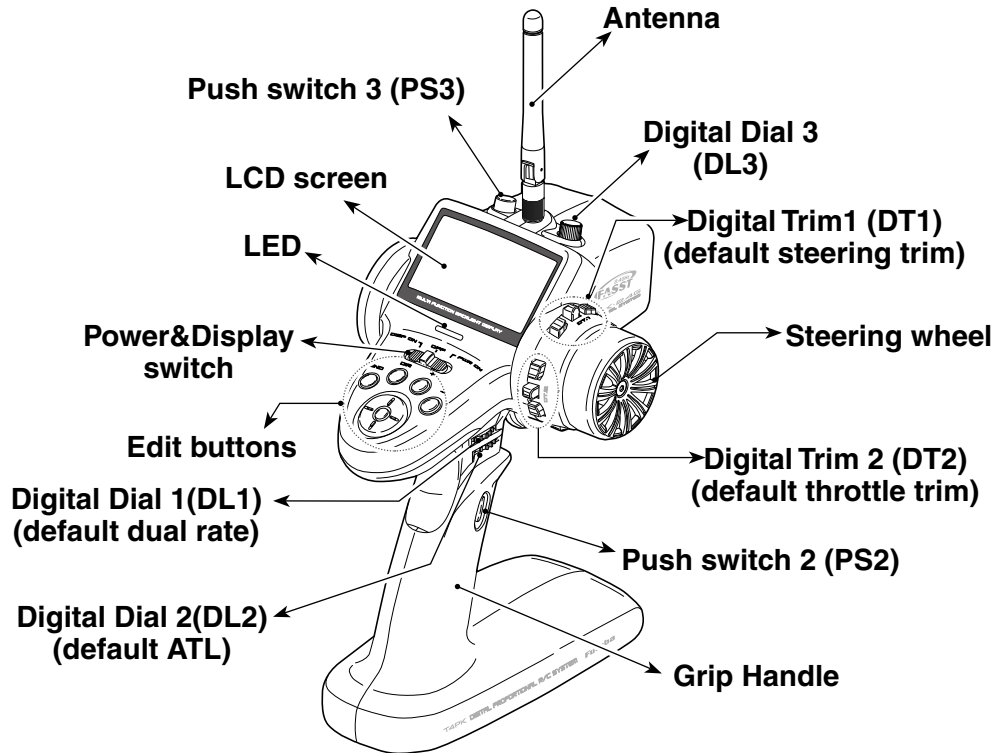

*The switches, dial, and trimmers in the figure are shown in the initial setting position.

Precautions when turning the power switch on and off.

When the data was changed using the edit keys or trim levers, wait at least two seconds before turning off the power. If the power is turned off within two seconds after the data was changed, the new data will not be written to memory.

Before Using

Power & Display Switch

The power switch and display switch of the T4PK are integrated. In the PWR ON mode, radio waves are transmitted and in the DISP ON mode, model data, settings can be checked without transmitting radio waves.

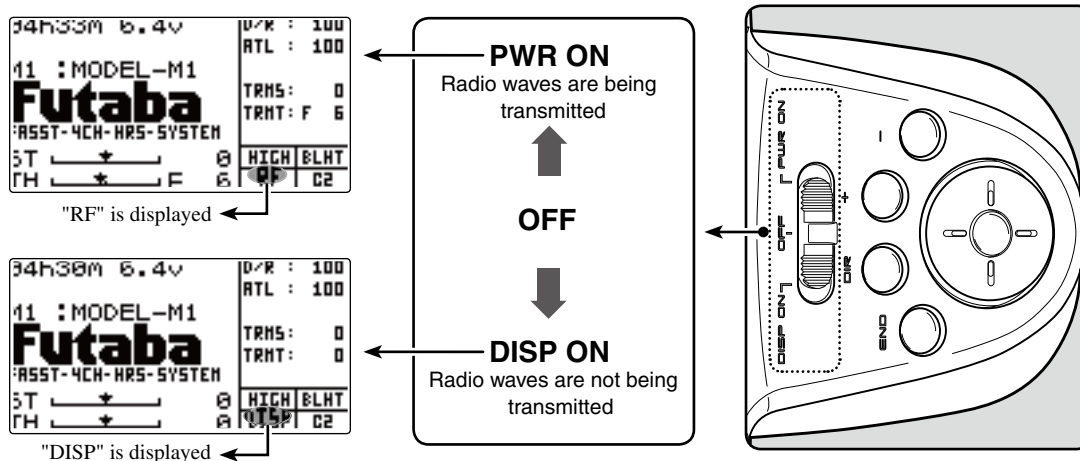

Before Using

Power Off Forgotten Alarm

When the steering wheel, throttle trigger, push switch, or edit button is not operated for 10 minutes during T4PK initialization, an alarm sounds and "NOT OPERATED FOR A LONG TIME" is displayed on the LCD screen.

When the steering wheel, throttle trigger, push switch, or edit button is operated, the alarm is reset. If the system is not to be used, turn off the power.

The function can be deactivated at the system menu (p.108).

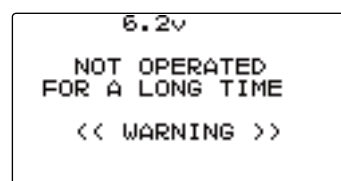

High Voltage Alarm

If a battery exceeding 8V is used with the T4PK, an audible alarm will sound and "HIGH VOLTAGE" will be displayed on the LCD screen.

Immediately remove the battery because it may cause damage to the T4PK.

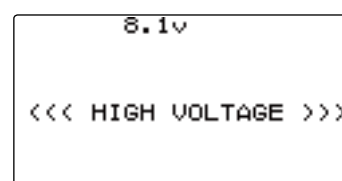

Low Battery Alarm

If the transmitter battery voltage drops to 5.0V (when using dry cell battery: 4.2V) or less, an audible alarm will sound and "LOW BATTERY" will be displayed on the LCD screen.

⚠ Warning

❶ When a low battery alarm is generated, cease operation immediately and retrieve the model.

If the battery goes dead while in operation, you will lose control of the model.

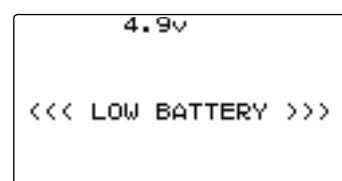

Digital Trim Operation

(Initial settings: DT1: Steering trim, DT2: Throttle trim, DT3: -----)

Digital trims can be used in 2 ways:

Operating by the lever: Push the lever to the left or right (up or down)
 Operating by push button switch: Press the push button switch in the desired direction. The current position is displayed on the LCD screen in the bottom three rows of the list. However, this operation cannot be performed when the trim/dial lock (p.22) function is set.

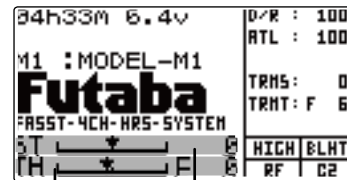
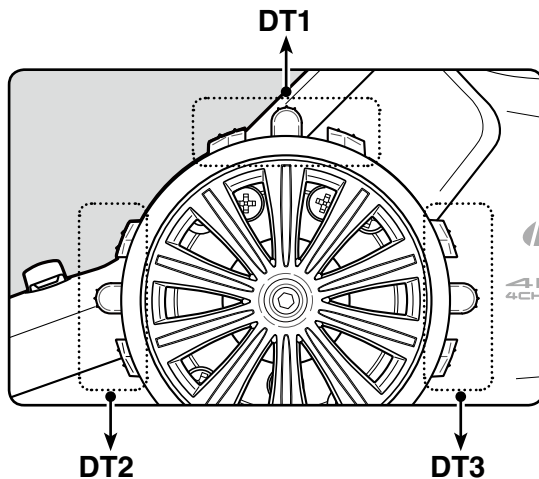

Steering trim display
 Throttle trim display

- Each step is indicated by a tone.
- When the trim exceeds the maximum trim adjustment range, the beep will change and the servo will not move any farther. Return to the neutral position (center) by pressing both the push button switches simultaneously for about one second.
- Trim lever adjustments have no effect on the maximum servo travel. This prevents the linkages from binding when adjustments are made.

Trim Operation

With the center trim feature, trim adjustments have no effect on the maximum servo travel. This prevents the linkages from binding when adjustments are made.

Grip Dial Operation

(Initial setting: DL1; Steering D/R, DL2; ATL)

Operate the dials by turning them. The current set value is displayed on the LCD screen. However, this operation cannot be performed when the trim/dial lock (p.22) function is set.

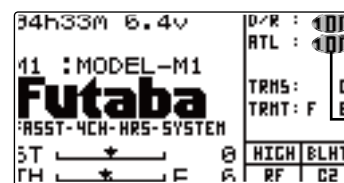
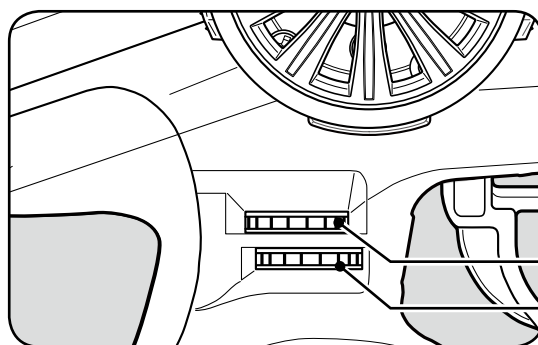

Steering D/R display

ATL display

Steering D/R DL1

ATL DL2

- Each step is indicated by a tone.
- When the trim exceeds the maximum trim adjustment range, the tone will change pitch and the servo will not move any farther.

Mechanical ATL Adjustment

Make this adjustment when you want to decrease the stroke of the brake (back) side of the throttle trigger for operation feel.

Adjustment

1 Using a 2.5mm hex wrench, adjust the trigger brake (reverse) stroke. (The screw moves the throttle trigger stopper.)

- When the screw is turned clockwise, the stroke becomes narrower. Adjust the stroke while watching the screw.

Mechanical ATL adjusting screw

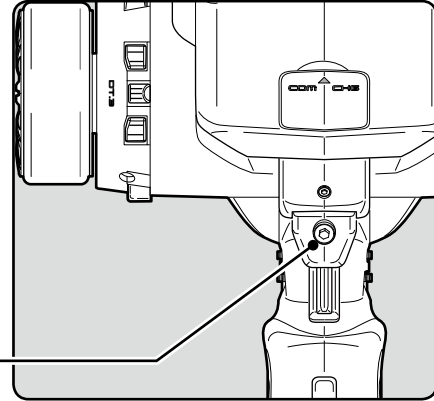

Note:

Once you have changed the mechanical stroke on the brake side, be sure to adjust the scale of the throttle channel accordingly by using the "Adjuster Function" (page 114).

Due to this change, you also need to adjust in most cases the travel of the throttle servo by using "Data Setting."

Wheel & Trigger Tension Adjustment

Make this adjustment when you want to change the wheel or trigger spring's tension.

Adjustment

1 Using a 1.5mm hex wrench, adjust the wheel spring tension by turning the screw inside the adjusting hole in the arrow direction.

- The spring is set to the weakest tension at the factory.
- When the adjusting screw is turned clockwise, the spring tension increases.

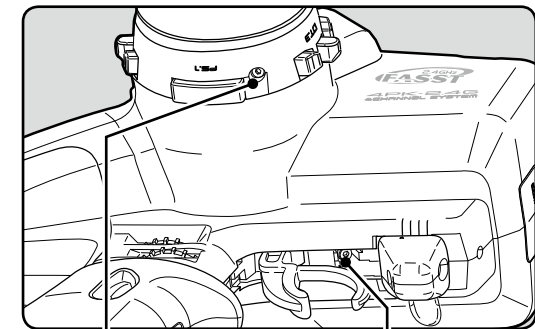

Wheel tension adjusting screw

Trigger tension adjusting screw

Note:

The adjustment range is up to 7 to 8 turns from the fully tightened (strongest) position. If turned further than this, the adjusting screw may fall out.

Trigger Slide Adjustment

The throttle trigger position can be moved forward and backward.

Adjustment

- 1 Using a 2.5mm hex wrench, loosen the trigger slide mounting screw by turning it slightly counterclockwise.
- 2 Using a 2.5mm hex wrench, turn the trigger slide adjusting screw, and adjust the trigger slide position within the marked range. When the adjusting screw is turned clockwise, the trigger slide moves away from the grip handle.
- 3 Retighten the mounting screw loosened at step 1 and fasten the trigger slide

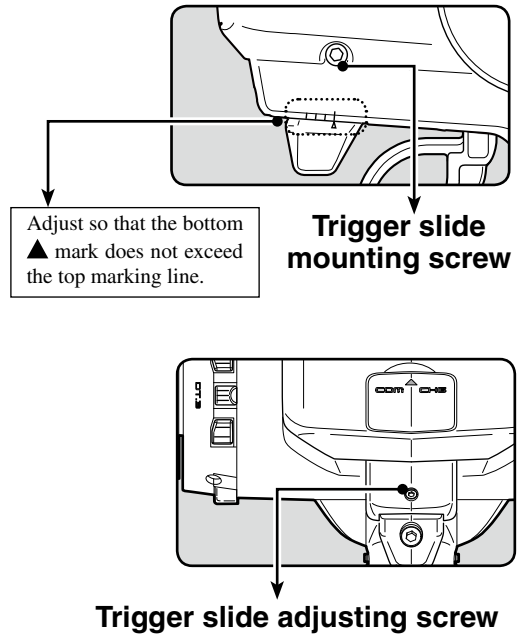

Ni-MH Battery Replacement

The Ni-MH battery is connected by a Futaba J connector so that it can be removed when you will not be using the transmitter for a long time, or when replacing a dead battery with a spare battery.

- Always use an HT5F1700B battery.

Removal

- 1 Slide the transmitter battery cover in the arrow direction while pressing the part shown in the figure.
- 2 Remove the Ni-MH battery and disconnect the connector.
- 3 Insert the connector of the new battery and load the battery into the transmitter.
- 4 Finish by installing the battery cover.

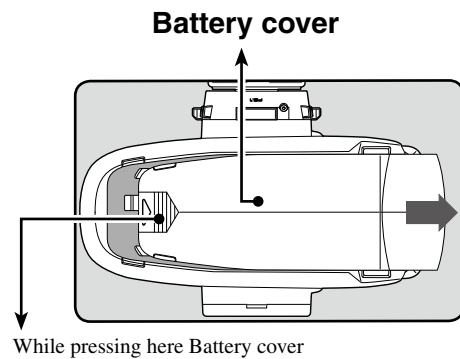

⚠ Caution

- 1 Pay full attention so that the battery cover does not pinch the cable of the Ni-MH battery. Pinching the cable by the battery cover can lead to an electrical shortage, fire and abnormal heat generation, which may cause burns and fire disaster.

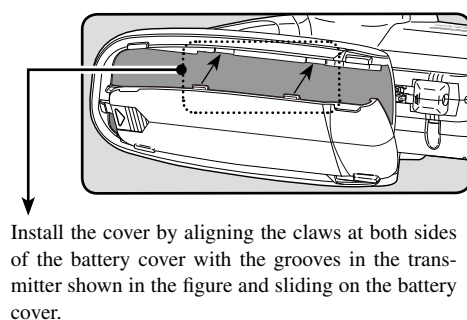

Charging The HT5F1700B Battery

Charging

- 1 Plug the transmitter cord of the special charger into the charging jack on the rear of the transmitter.
- 2 Plug the charger into an AC outlet.
- 3 Check that the charging LED lights.

When charging the HT5F1700B battery with the special charger, allow about 15 hours for charging. If the transmitter has not been used for some time, cycle the battery by charging and discharging it two or three times.

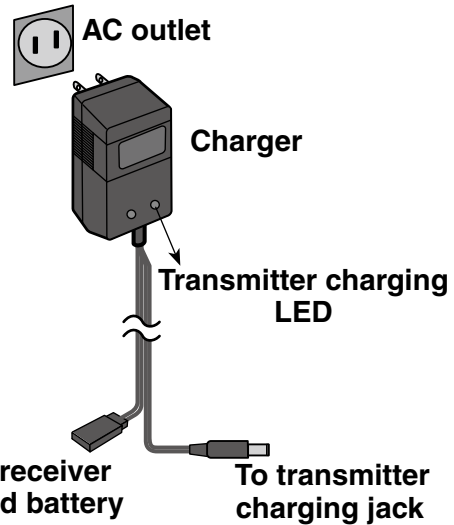
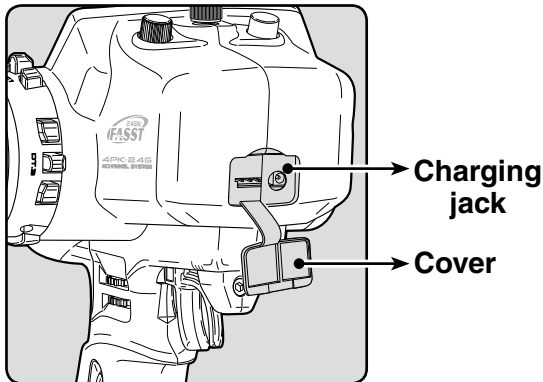

When using Futaba CR-2000

The HT5F1700B is 5-cells, so, when charging the HT-5F1700B battery with Futaba CR-2000 charger, you have to use the RX output side.

Over current protection

The transmitter charging circuit is equipped with an over current protection circuit (1.7A). If the battery is charged with a quick charger for other than digital proportional R/C sets, it may not be fully charged.

Before Using

⚠ Warning

- ⊘ Never plug it into an outlet other than indicated voltage.
Plugging the charger into the wrong outlet may result in an explosion, sparking, or fire.
- ⊘ Do not insert and remove the charger when your hands are wet.
It may cause an electric shock.
- ⓘ Always use the special charger or a quick charger for digital proportional R/C sets to charge a digital proportional R/C set Ni-MH battery.
Overcharging a Ni-MH battery can result in burns, fire, injuries, or loss of sight due to overheating, breakage, or electrolyte leakage.

⚠ Caution

- ⊘ Never try to recharge a dry cell battery.
The transmitter may be damaged or the battery electrolyte may leak or the battery may break.
- ⓘ When the charger is not in use, disconnect it from the AC outlet.
Do this to prevent accidents and to avoid overheating.

Grip Vibrator

A vibrator is built into the grip of the T4PK. The vibrator vibrates at racing timer lap navigation, time-up, and low battery alarm. (p.116)

Display when power switch is turned on

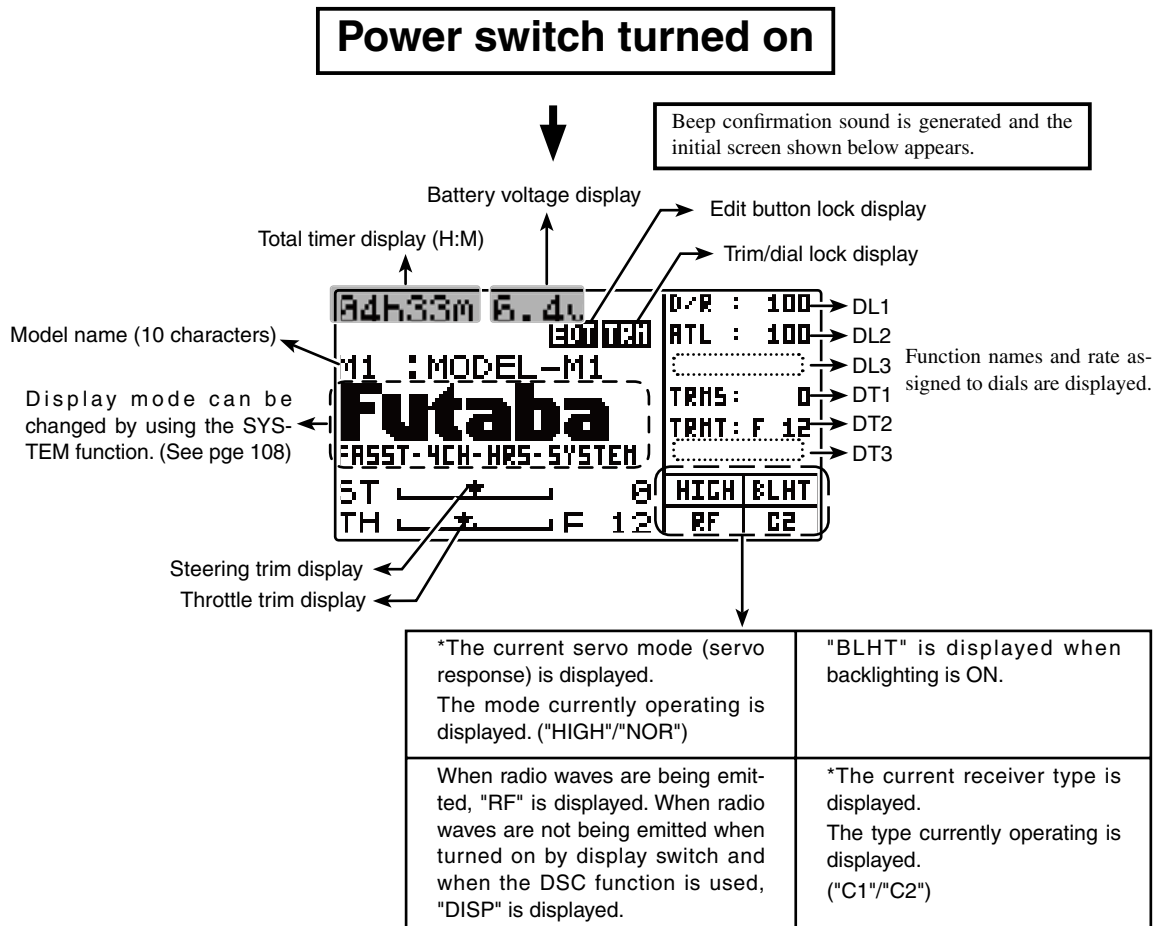

Before Using

Power supply and voltage display

Dry cell batteries (alkali batteries are recommended) can be used with the optional battery box. However, when using dry cell batteries, set BATT-TYPE in the system menu to DRY 4CELL. When BATT-TYPE is set to DRY 4CELL, the voltage display of the initial screen will change to the **6.4V** symbol.

When using the T4PK standard HT5F1700B battery, always set BATT-TYP to NIMH 5CELL. (See page 108, for a detailed description of the battery types.)

User name display

When the (END) button is held down for 1 second or longer at the initial screen, the Futaba logo and user name are displayed for about 2 seconds.

Edit button lock and trim/dial lock

T4PK setup and operation by edit button (p.15) and digital trim DT1, DT2, and DT3 and dials DL1, DL2, and DL3 can be prohibited.

Setting

1 Edit button lock: When the (+) button is pressed for about 1 second at the initial screen, a confirmation beep is generated and the edit button lock display **EDT** appears on the screen.

Trim/dial lock: When the (-) button is pressed for about 1 second at the initial screen, a confirmation beep is generated and the trim/dial lock display **TRM** appears on the screen.

Clearing

1 Edit button lock and trim/dial lock can be cleared in the initial screen state by the same method as the setting described above. (The edit button lock display **EDT** or trim/dial lock display **TRM** disappears from the screen.)

Total Timer

The total timer shows the accumulated time from last reset.

The total time does not change even when the model changes.

Reset method

1 In the initial screen state, hold down the (+) and (-) buttons simultaneously for 1 second.

* The total timer display counts up from 1 minute to 99hours 59 minutes.

LCD Screen Contrast

The LCD screen contrast can be adjusted. (For more information, see page 108.)

Caution

Do not adjust the contrast so that the LCD is too bright or too dark.
When the display cannot be read due to a temperature change, data cannot be set.

LCD Screen Temperature Change

In the following cases, the LCD may become difficult to read due to a temperature change.

- On hot summer days and cold winter days, the LCD may be easy to read indoors, but difficult to read outdoors.
- If the contrast is too bright or too dark, temperature changes and lighting conditions may cause the screen to become difficult to read.

Contrast adjustment from main screen

1 Turn on the transmitter.

2 If the screen is too dark, adjust the contrast by pressing the (-) button while pressing the (JOG) button. If the screen is too light, adjust the contrast by pressing the (+) button while pressing the (JOG) button.

Changing wheel position and modifying for left-hand use

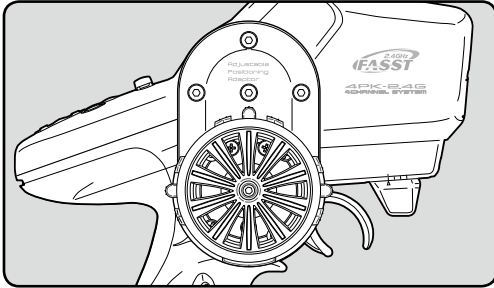

Changing the wheel position

The wheel position can be offset by using the accessory APA wheel position offset adapter. (See the page 24 for the modification method.)

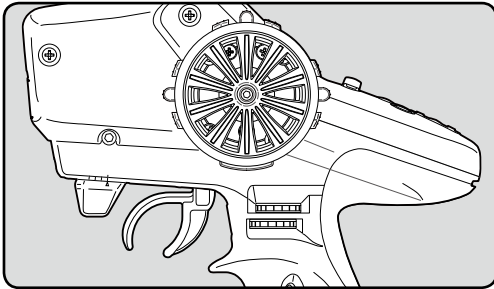

Modifying for left-hand use

The wheel section left and right installation direction can be reversed.

(See the page 26 for the modification method.)

Angle can be adjusted

The angle can be finely adjusted by adjusting the steering wheel unit installation. (See the modification method on the next page for the adjustment details.)

Removing the steering wheel unit

- Obtain a 2.5mm hex wrench and philips screwdriver.

1 Hold the wheel and remove the screw.

Steering wheel mounting screw

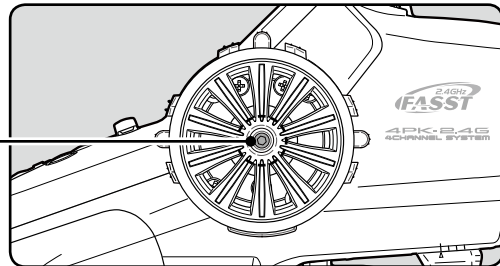

2 Pull off the wheel.

Wheel

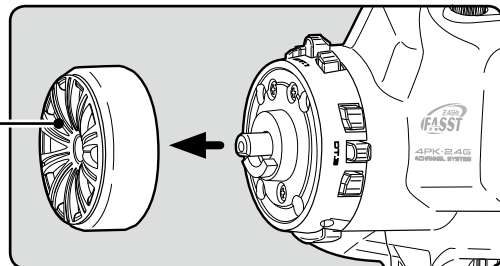

3 Remove the 3 steering wheel unit mounting screws.

Unit mounting screws

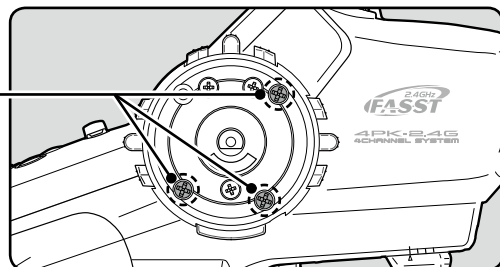

- 4** Remove the steering wheel unit.
 •Be careful not to stretch the wiring.

- 5** Disconnect the steering wheel unit connector.

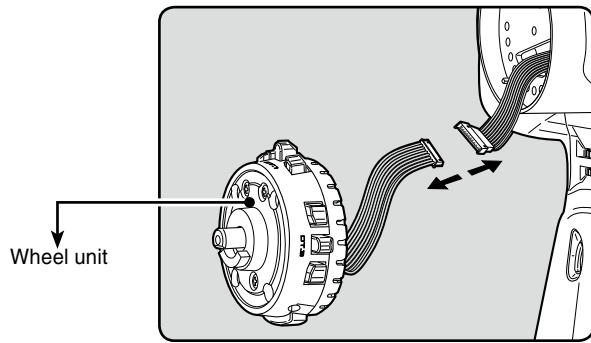

Installing the accessory APA steering wheel offset adapter

- Obtain a 2.5mm hex wrench and philips screwdriver.
- Install the steering wheel unit, removed as described on the preceding page, as follows:
- The length of the screws used at each part differs .When reassembling the steering wheel unit, always use the original screws.

- 1** The steering wheel unit connector through the adapter.

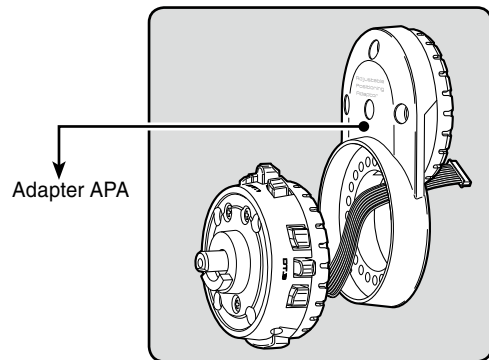

- 2** Install the steering wheel unit using the 3 mounting screws.

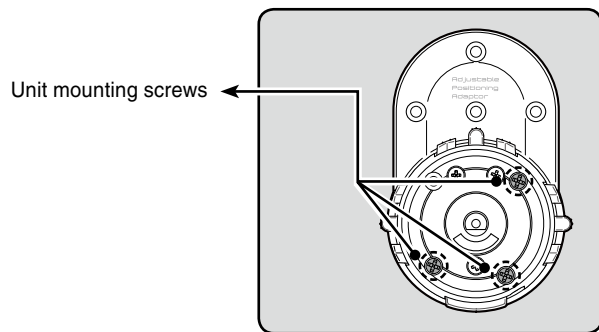

- 3** Connect the steering wheel unit connector.
 (be careful of the direction of the connector)

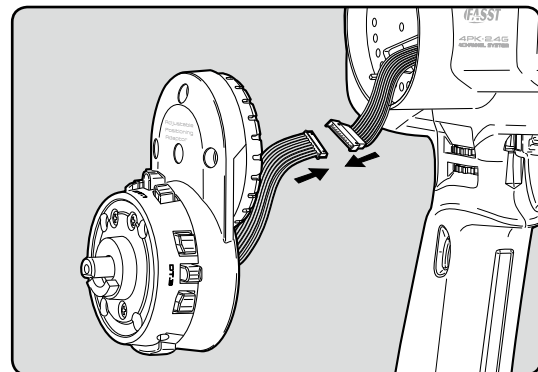

3 Pull out the wiring as far as possible from between the wheel unit and APA. Stow the surplus pulled out wiring in the transmitter.

•Be careful not to stretch the wiring.

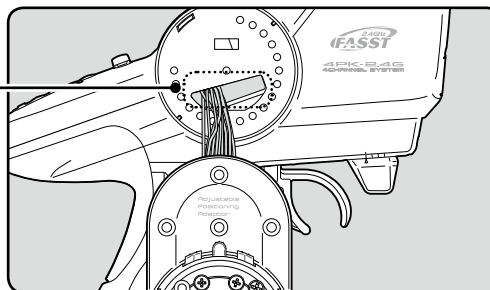
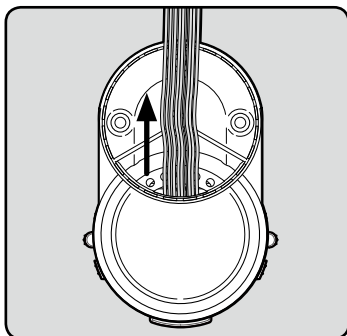

Stow the surplus wiring here.

4 Install the assembled wheel unit and APA to the transmitter using the screw supplied. The APA mounting screws are in the hook and APA mounting screws bag. Verify the position of the transmitter bottom holes by mounting angle. The screw used depends on the position of the bottom hole.

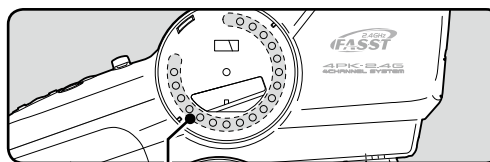

Transmitter bottom hole

Before Using

*The figure below is an installation example.

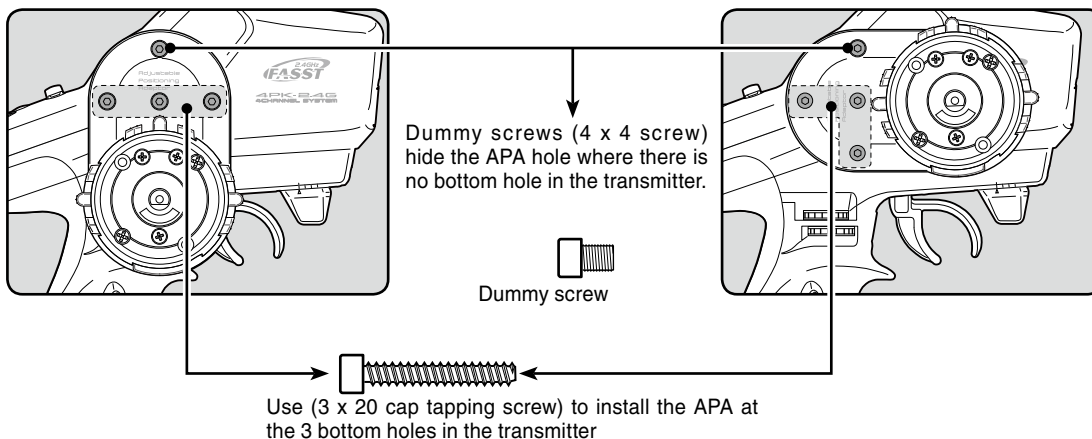

5 Install the steering wheel using the screw.

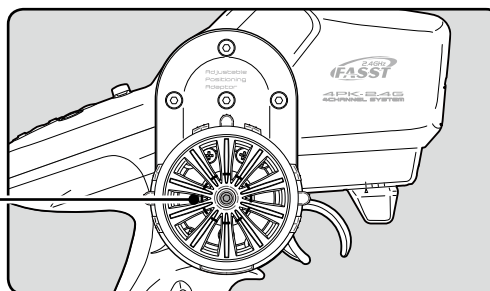

Steering wheel mounting screw

Modifying for left-hand use

- Obtain a 2.5mm hex wrench and philips screwdriver.
- Install the steering wheel unit removed as described on the preceding page as follows:

1 Remove the wheel section rear cover .

- The rear cover can be easily removed by inserting a coin, etc. into the slot at the bottom of the rear cover.

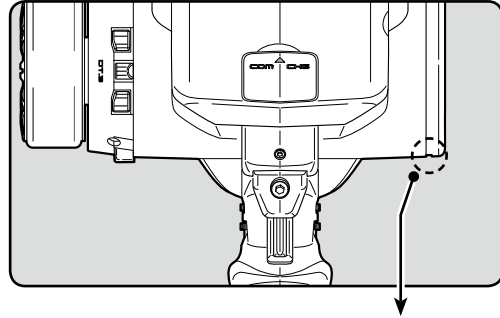

2 Push in the disconnected connector so that it can be connected at the opposite side.

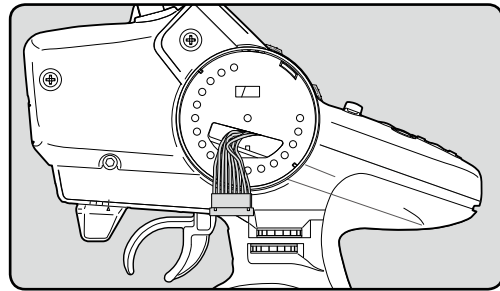

3 At the opposite side, connect the steering wheel unit connector and Install the steering wheel unit, steering wheel cover, and wheel to their original positions.

- At this time, be sure that the wiring is not pinched between the wheel unit and transmitter.

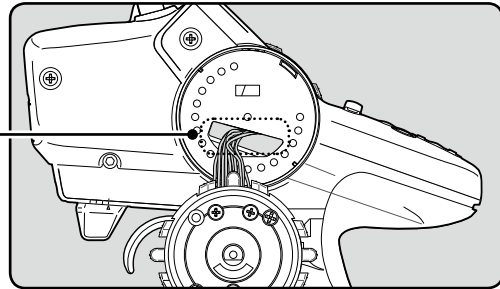

Stow the surplus wiring here.

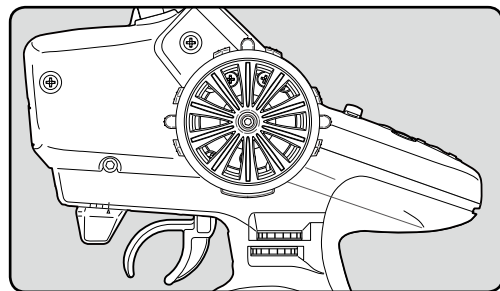

Installing the accessory Hook

A hook can be installed to the T4PK, as required.

The hook is in the hook and APA mounting screws bag supplied with the set.

- Obtain a philips screwdriver.
- Pull up the grip rubber.

1 Pull up the bottom of the grip rubber as shown in the figure.

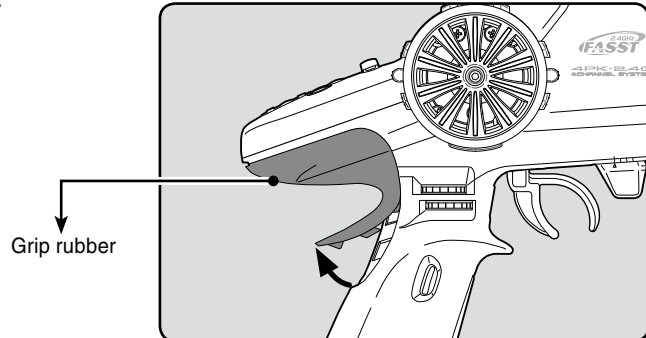

2 Pull out the grip rubber in the arrow direction.

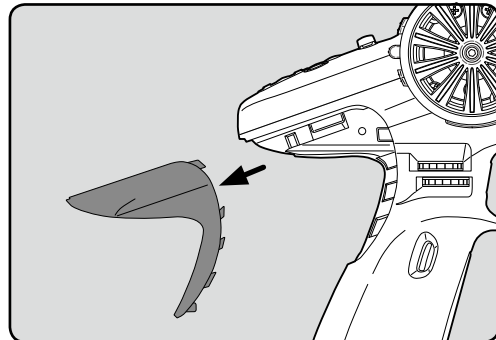

3 There is a mounting nut inside the transmitter. Install the hook at the position shown in the figure using the accessory screw w/washer.

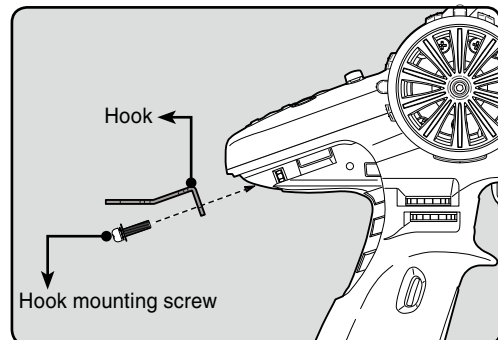

4 Return the grip rubber to its original position.

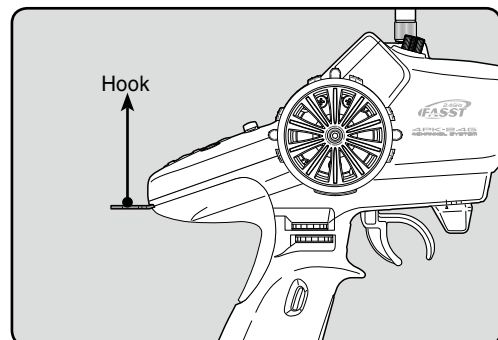

Before Using

About Transmitter Antenna and Receiver

About The Transmission Antenna

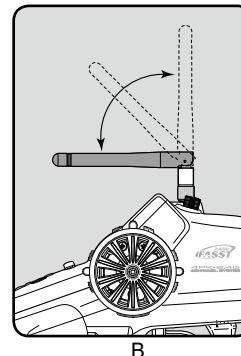
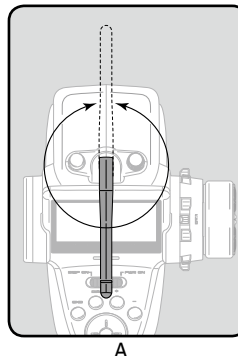
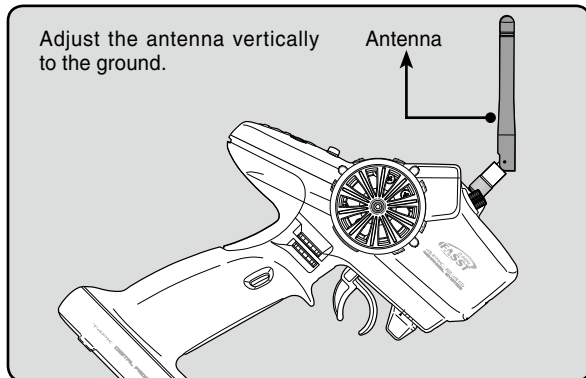

Antenna Moving Range

Before Using

⚠ Warning

- ❗ Adjust the antenna vertically to the ground.

Otherwise, the operating range may become shorter.

- ⊘ Never hold only the antenna.

Hold the grip handle, otherwise the antenna may be damaged.

- ⊘ The antenna position can be changed in the range as shown in figures A and B. However, please do not apply unnecessary force or shock.

The internal cable may be damaged; thus transmitting distance decreases and it may cause malfunction.

- ⊘ The antenna is a screw-on type and can be removed. However, do not remove the antenna except when it must be replaced.

If the transmitter antenna terminals get dirty, the radio wave output will become weak and there is the danger that the receiving range will be substantially shortened.

- ❗ When the antenna is changed, it requires the metal part of the antenna to be held firmly while putting it on.

The antenna can not be mounted to T4PK (by rotating the middle part of the antenna).

There might be small glitch when the antenna of transmitter is brought close to servos, ESCs or other peripheral devices.

This is not an issue but please keep this symptom in mind especially when setting-up.

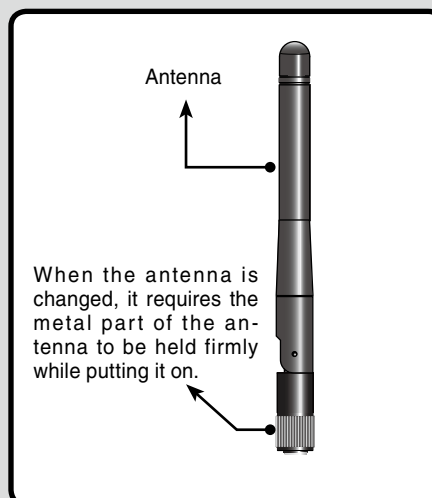

Receiver Terminology

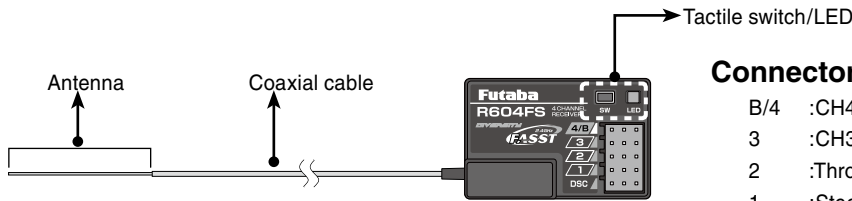

Connectors

- B/4 : CH4 servo(CH4)/Power connector
- 3 : CH3 servo(CH3)
- 2 : Throttle servo(CH2)
- 1 : Steering servo(CH1)
- DSC : DSC connector

How to link the transmitter and the receiver

Each transmitter has an individually assigned, unique ID code. In order to start operation, the receiver must be linked with the ID code of the transmitter to which it is being paired. Once the link is made, the ID code is stored in the receiver and no further linking is necessary unless the receiver needs to be used with another transmitter.

Link procedure

- 1** Bring the transmitter and the receiver close to each other, within 20 inches (half meter).
- 2** Turn on the transmitter.
- 3** Turn on the receiver.
- 4** Push the tactile switch of the receiver.
When the link is complete, the LED in the receiver changes to solid green.

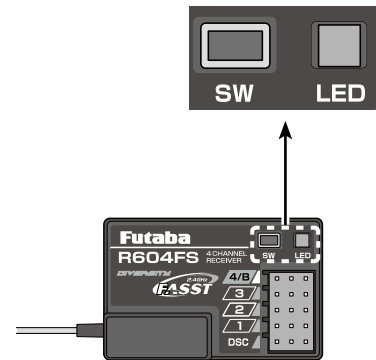

Before Using

Precaution:

If there are many FASST systems turned on in close proximity to the R603FS/R603FF/R604FS, your receiver might not link to your transmitter. In this case, even if the receiver's LED stays solid green, unfortunately the receiver might have established a link to one of other transmitters. This is very dangerous if you do not notice this situation. In order to avoid the problem, we strongly recommend you to double-check whether your receiver is really under control by your transmitter by giving the stick input and then checking the servo response.

⚠ Warning

- ❶ After the linking is done, please cycle receiver power and check if the receiver to be linked is really under the control of your transmitter.
- ❷ Do not perform the linking procedure with motor's main wire connected or the engine operating as it may result in serious injury.

*Please refer the table below for LED status vs receiver's condition.

LED status vs receiver's condition:

No signal reception	Red : On
Receiving signals	Green: On
Receiving signals, but ID is unmatched.	Green: Blink
Unrecoverable failure (EEPROM, etc.)	Red and Green turn on alternately

Receiver Installation

Install the R604FS receiver on the car as follows:

The operating range may become shorter, depending on where the receiver and the antenna are mounted.

Before Using

⚠ WARNING

- ⊘ Do not cut or bundle the receiver antenna wire.
- ⊘ Do not bend the coaxial cable. It causes damage.
- ❗ Install the antenna in the higher place as shown in the figure.
- ❗ Put the antenna in the antenna tube to protect it.
- ❗ Keep the antenna as far away from the motor, ESC and other noise sources as you possibly can.
- ❗ Wrap the receiver with something soft, such as foam rubber, to avoid vibration. If there is a chance of getting wet, put the receiver in a waterproof bag or balloon.

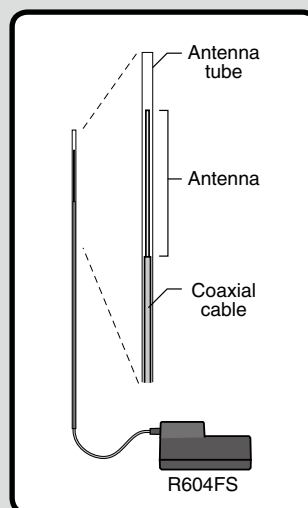

Note: Since the receiver generates a certain amount of heat, change the mounting method to improve the ventilation at the receiver. If the receiver is too tight, it may malfunction when the ambient temperature is high.

⚠ Caution

- ❗ Always use R604FS under the following conditions:

Battery : 6V Ni-Cd battery

RX Type: FASST-C2(See p.46 for setting method.)

Transmitter mode-HIGH SPEED mode : 6V Futaba digital servo(See p.46 for setting method.)

Transmitter mode-NORMAL mode : 6V Futaba all servo(See p.46 for setting method.)

Under other conditions, the set will not operate, or the specified performance will not be displayed even if it operates. In addition, it may cause trouble of servo and other equipments. Futaba will not be responsible for damage, etc. caused by combination with the products of other companies.

In addition, the FSU1 Fail Safe Unit cannot be used because the system is different. Use the fail safe function of the transmitter.

Transmitter mode setting

Set the transmitter to the HIGH SPEED mode or NORMAL mode. See page 46 for a description of the setting method.

Note: However, use of a digital servo (including BLS Series brushless servo) can only be used in the HIGH SPEED mode.

When the power is turned on, whether the receiver is in the HIGH SPEED or NORMAL mode is judged and the R604FS operates in that mode until the power is turned off. When the transmitter mode was changed, operation becomes possible when the receiver power is turned on again. When the frequency band was changed, reception on the new frequency band becomes possible when the receiver power is turned on again.

For the receiver, servos, and other connections, see page 31 For the DSC cord (option) connections, see page 123.

Installation

Receiver and Servo Connections

Connect the receiver and servos as shown below. Connect and install the receiver and servos in accordance with "Installation Safety Precautions" on the next page.

The figure shown below is an example. The method of connecting the motor controller to the motor and battery depends on the motor controller used. Purchase the motor controller and servos separately. The receiver also depends on the set.

When using a 4-channel servo, connect the optional double extension cord to 4/B of the receiver and connect the 4-channel servo and receiver switch to the connection at the opposite side.

Installation When A Electronic Speed Control Is Used

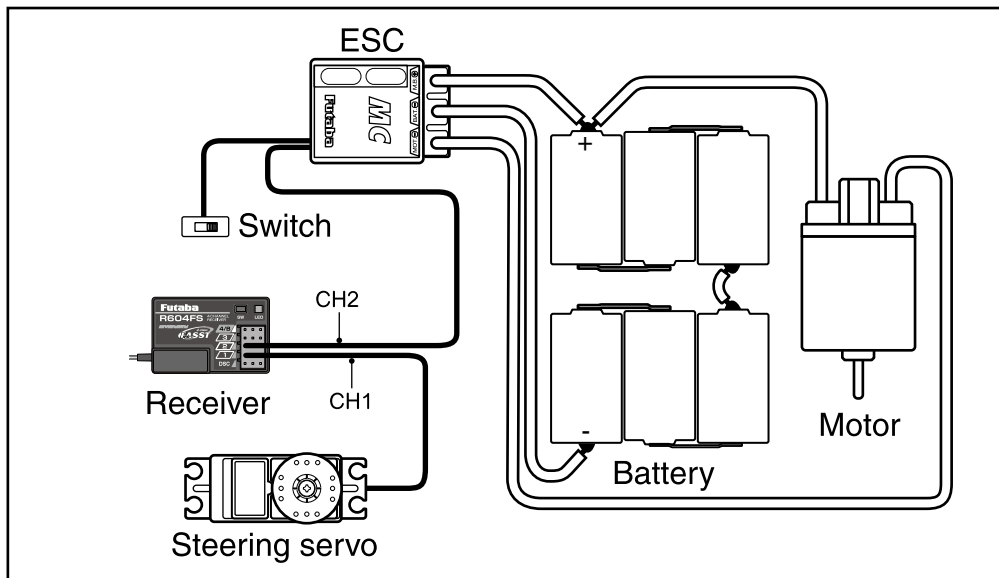

Installation For Gas Powered Models

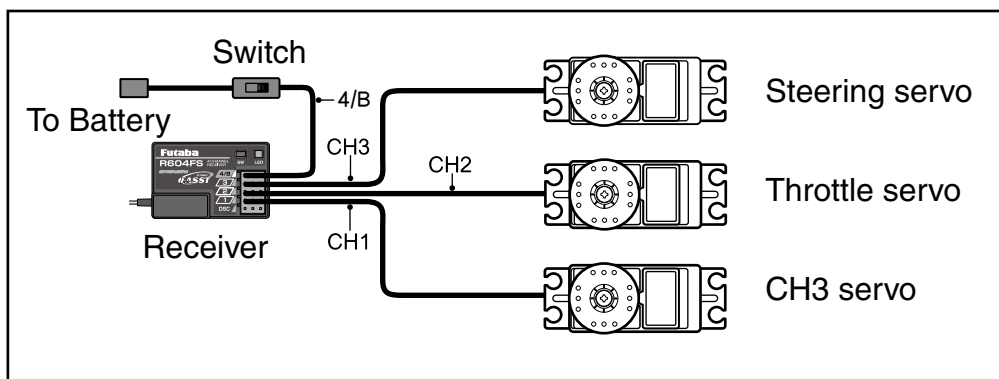

Installation Safety Precautions

⚠ Warning

Receiver (receiver antenna)

- ⊘ Do not cut or bundle the receiver antenna wire.
- ⊘ Do not bundle the receiver antenna wire together with the motor controller lead wire.
- ⊘ Keep the receiver antenna wire at least 1cm away from motor, battery, and other wiring carrying heavy current.
- ⊘ Do not use a metal receiver antenna holder on a plate made of metal, carbon, or other conductive material.
- ❗ Install the receiver antenna holder as close as possible to the receiver.

If the antenna wire is cut, bundled, or routed near a noise source, the receiving sensitivity will drop, the running (sailing) range will decrease, and you may lose control of the model.

*Noise is transmitted through metal, carbon, and other conductive material, so keep the receiver antenna wire away from such parts.

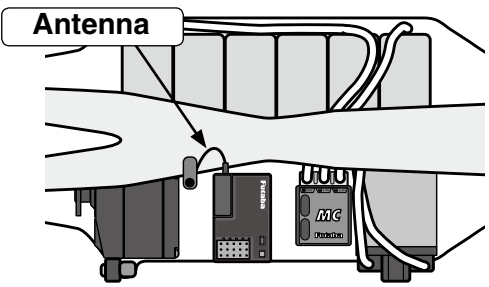

Antenna

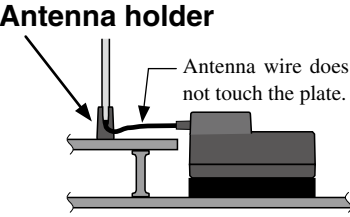

Antenna holder

Install the receiver as far away as possible from the battery, motor controller, motor, silicon cord and other noise sources. Keep it away from the antenna wire, in particular.

Install the antenna holder as close as possible to the receiver. The surplus antenna wire from the receiver to the antenna holder is affected by noise. Do not use a metal antenna holder on a plate made of metal, carbon, or other conductive material.

Receiver vibration-proofing / waterproofing

(Car)

- ❗ Vibration-proof the receiver by wrapping it in foam rubber or other vibration-absorbing material and mount it with thick double-sided tape.
- ❗ When using the receiver holder supplied with the model kit, mount the holder to the chassis through a rubber grommet.

(Boat)

- ❗ Vibration-proof the receiver by wrapping it in foam rubber or other vibration-absorbing material. Also waterproof the receiver by sealing it in a plastic bag.

If the receiver is exposed to strong vibration and shock, it will operate erroneously due to the invasion of water drops and you may lose control of the model.

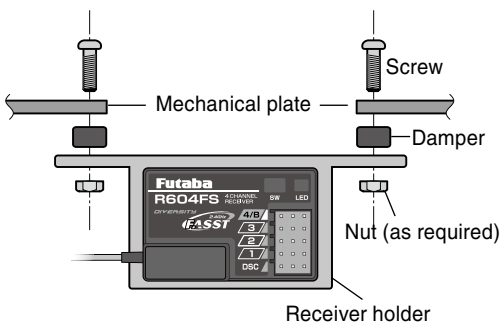

When using the receiver holder supplied with the kit, install the receiver through a rubber grommet.

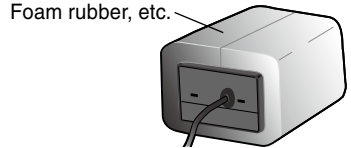

Wrap the receiver in foam rubber or other vibration-absorbing material. Do not use hard material. Hard material does not have a vibration-proofing effect.

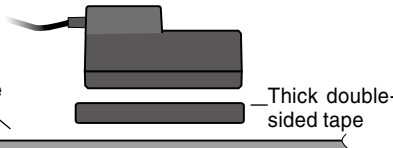

When mounting the receiver with double-sided tape, do not use a stiff tape. Stiff tape does not have a vibration-proofing effect.

⚠ Warning

Connector Connections

- ❗ Be sure the receiver, servo, battery and connectors are fully and firmly connected.

If vibration from the model cause a connector to work loose while the model is in operation, you may lose control .

Servo Installation

- ❗ When you install the servos, always use the rubber grommets provided in servo hardware bags. Mount the servos so they do not directly come in contact with the mount.

If the servo case comes in direct contact with the mount, vibration will be directly transmitted to the servo.

If this condition continues for a long time the servo may be damaged and control will be lost.

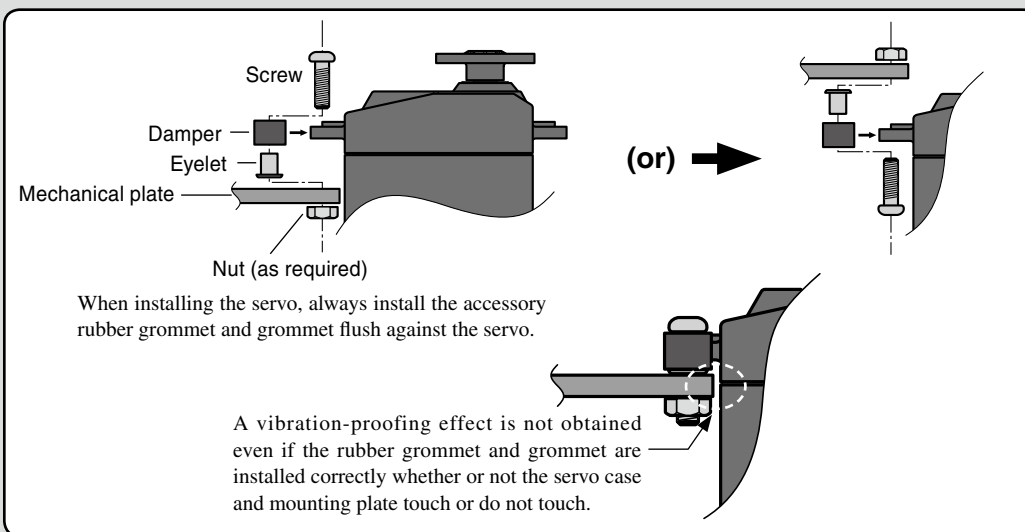

Servo Throw

- ❗ Operate each servo over its full stroke and be sure the linkage does not bind or is loose.

The continuous application of unreasonable force to a servo may cause damage and excessive battery drain.

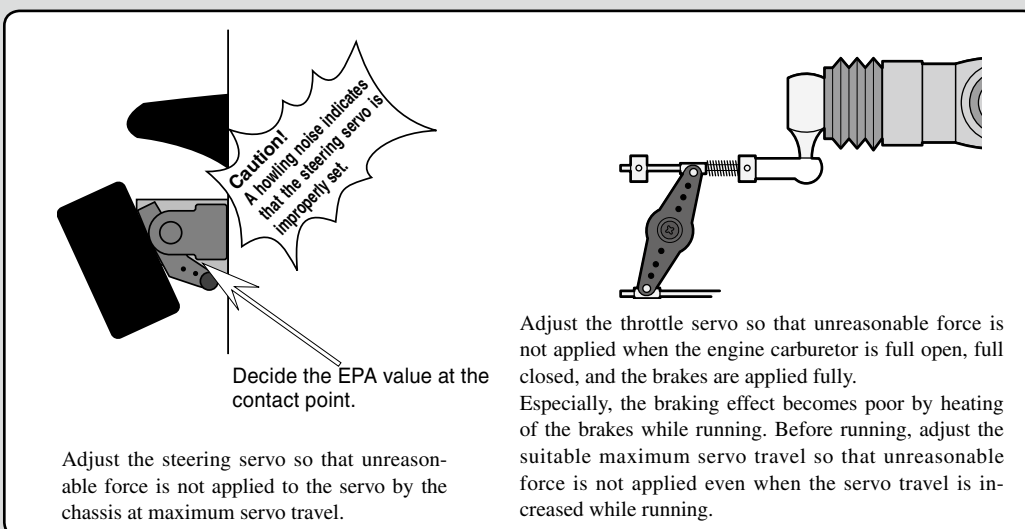

⚠ Warning

Electronic speed control

- ❶ Install the heat sinks where they will **not** come in contact with aluminum, carbon fiber or other parts that conduct electricity.

If the FET Amp (Electronic speed control) heat sinks touch other materials that conduct electricity a short circuit could occur. This could result in loss of control and damage to the system.

Motor Noise Suppression

- ❶ Always install capacitors to suppress noise when electric motors are used.

If capacitors are not properly installed you could experience erratic operation and reduced range as well as loss of control.

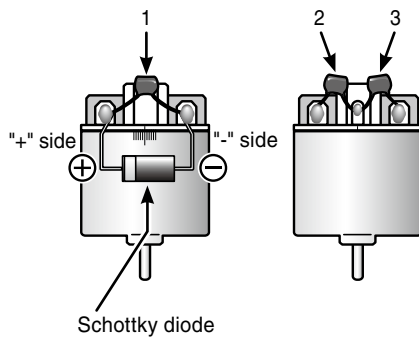

Motors with no suppressor capacitors, or inadequate suppression, may cause the receiver to malfunction. Always solder the capacitors supplied to your motor.

The schottky diode improves the efficiency of the speed control / motor combination and provides extra protection to the brake FETs. The white ring must always face the positive side.

Other Noise Suppression Methods

- ❶ Be sure there are no metal parts in your model which under vibration can come in contact with other metal parts.

Metal to metal contacts under vibration will emit a high frequency noise that will affect the receiver's performance. You could experience erratic operation and reduced range as well as loss of control.



Initial set-Up

Preparations (Transmitter)

Before setting the Transmitter functions, check and set items 1 to 5 below.

(Display when power switch turned on)

When the power switch is turned on, the currently selected model number is displayed. Check if this number is the model number you want to setup. To change the model number, use the Model Select function (See page 98).

Turn on the transmitter power.



(Start screen)

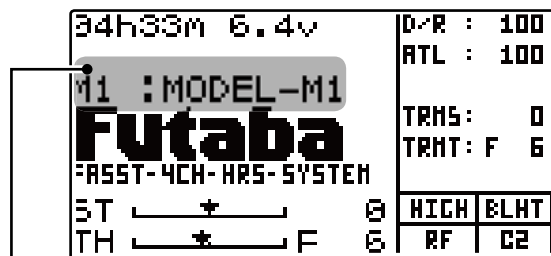

The model number is displayed.

1.RF Output Check

If signals are output normally, RF output monitor "RF" will be displayed on the screen.

If "RF" is not displayed, check if the transmitter crystal and RF module are installed.

If the transmitter is abnormal or faulty, contact your Futaba dealer.

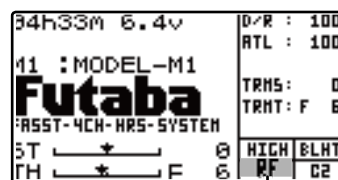

"RF"

When radio waves are not being emitted when turned on by display switch and when the DSC function is used, "DISP" is displayed.

2.Rx Type Check

The T4PK transmitter can use the Futaba 2.4GHz R603FS/FF. However, there are two types of Futaba 2.4GHz receiver for vehicles: "C1" type and "C2" type. The R603FS and 603FF are "C1" type. The R604FS supplied with the 4PK set as standard is the "C2" type. Check that the setting matches the receiver being used. For example, when using the R604FS, the receiver type must be set to FASST-C2 and when using an R603FS or R603FF, the receiver type must be set to FASS-C1. If the setting is wrong, change it using the RX/SX type select function (page 46).

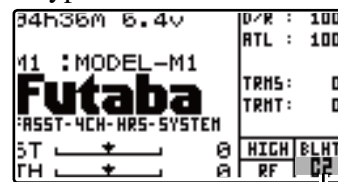

"C2"

When FASST-C2

3. Servo Response Mode Check

Check that the servo response setting matches the servo being used. When using a digital servo (including BLS Series brushless servo), both HIGH SPEED and NORMAL can be used. When an analog servo is used, HIGH SPEED cannot be used; therefore, servo response must be set to NORMAL. If the setting is wrong, change it using the RX/SX type select function (page 46).

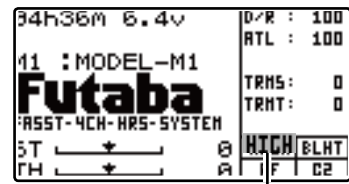

"HIGH"
When HIGH SPEED

4. Throttle Mode Check

-When using the T4PK transmitter with a boat, throttle brake operation can be shut down by setting the BOAT function (p.78)
*TRG-BRK item to "Cut-OFF".

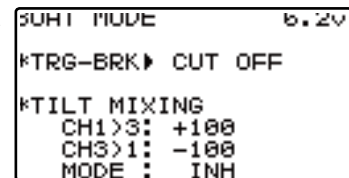

-The throttle servo travel can be set to 50:50 or 70:30 for throttle trigger operation as required by the throttle mode function (page 80).

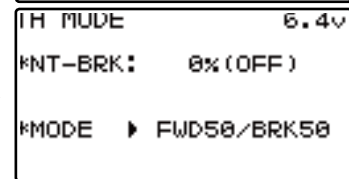

5. Trims Initial Set-Up

- Steering trim (DT1) check

At initial set-up, steering trim is assigned to the DT1 trim lever above the steering wheel. Operate the lever and make sure the marker moves on the ST graph. If default has been changed, test steering trim in its new location. After checking the trim, set the trim display to the center (N) position.

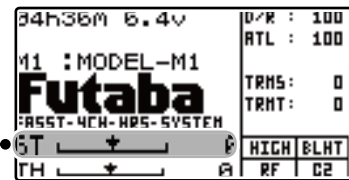

- Throttle trim (DT2) check

At initial set-up, throttle trim is assigned to the DT2 trim lever left side the steering wheel. Operate the lever and make sure the marker moves on the TH graph. If default has been changed, test throttle trim in its new location. After checking the trim, set the trim display to the center (N) position.

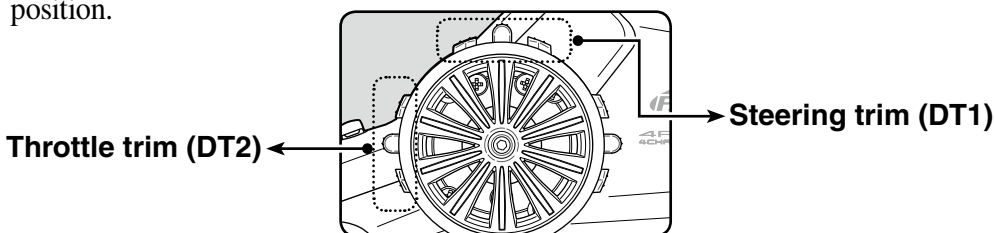
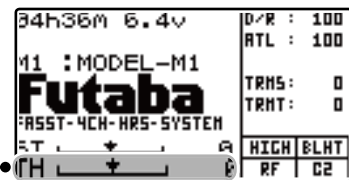

- Steering dual rate (BT1) check

At initial set-up, steering dual rate (D/R) is assigned to DL1 dial, at the grip of the transmitter. Operate the DL1 and check if the D/R value displayed on the screen changes. After checking ST.D/R, set the steering dual rate to 100%.

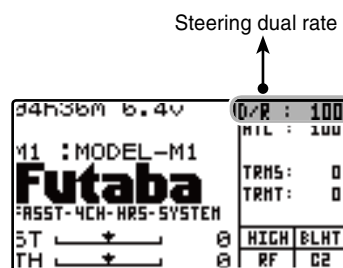

- Throttle ATL (BT2) check

At initial setting, throttle ATL (ATL) is assigned to DL2 dial, below DL1. Operate the DL2 and check if the ATL value displayed on the screen changes. After checking TH.ATL, set throttle ATL to 100%.

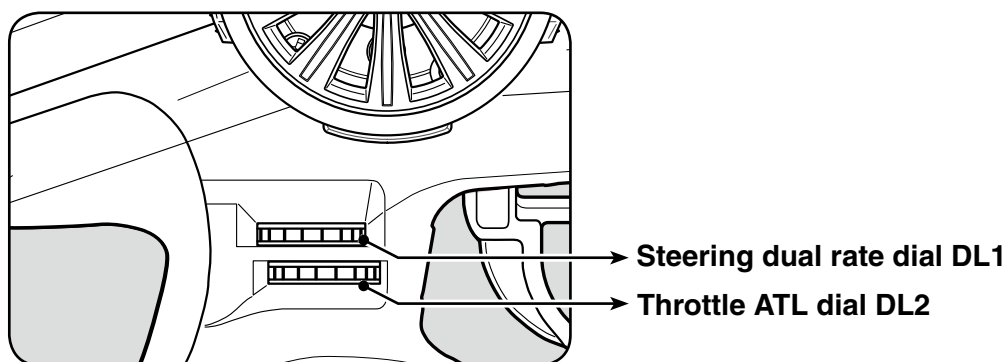
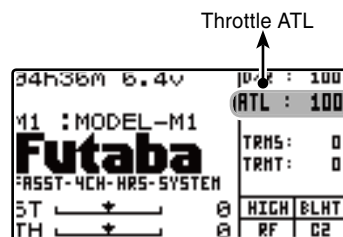

(Set-Up Procedure When Installed In a Car)

When installing the servos in a car, performing function set-up in the following order is recommended.

- 1** Perform step 1 to 5. Trims Initial Set-Up of Preparations on the preceding page.
- 2** Set the servo direction of operation using the Reverse function. (p.47)
 - The servo installation method and linkage direction depends on the kit. Therefore, the servo operation direction may have to be reversed relative to transmitter operation. Before installing the servo, check the operating direction and set it using the Reverse function.
- 3** Set the subtrim and adjust the servo neutral point. (p.48)
- 4** Set the trigger travel by adjusting the throttle trigger mechanical ATL to your liking. (p.18)
 - When the stroke was adjusted, compensate the throttle by adjuster function (See page114).
- 5** Set EPA of each channel and adjust the servo throw (travel). (p.49)

Function Map

Menu Selection

The function set-up screen can be easily selected from the function menu displayed on the LCD screen.

The function menu can be selected from among the following 4 types to match the level of use. To select the type, use the Menu type select function (page 103).

- Level 1 (LEVEL1) : Basic functions only
- Level 2 (LEVEL2) : For middle class driver
- Big car(BIGCAR) : Displays the main functions for large cars (1/5).
- Level 3 (LEVEL3) : All functions can be selected. (For expert driver)

* In addition to the menu types shown above, there is ALLOFF. It is convenient when customizing all menus.

This menu consists of 3 fixed functions; *M-SEL (model select), *M-RES (model reset), and * MENU-T (menu type select), and cannot be moved or deleted.

Edit Buttons

In this instruction manual, Edit Buttons are represented by the symbols shown below.

Function Menu Screen

Function Map

Call the menu screen by **JOG** button up, down, left, or right operation.

(Opening Screen)

↑ ↓ ← → **JOG**

Press the **END** button to return to the Start Screen

LEVEL1

MENU 1	OF	
EPA	RXSYS	SYSTEM
REV	F/S	*M-SEL
SUBTR	NAME	*M-RES
		*MENU-T

← →

+

Press

MENU 2

MENU 2	OF	
STEXP	DIAL	MCLNK
THEXP	SWTCH	ADJST
A.B.S	BOAT	THMOD
M-COP	DTTRN	UTRPA

LEVEL2

MENU 1	OF	
STEXP	EPA	SYSTEM
THEXP	SUBTR	NAME
IDLUP	REV	*M-SEL
A.B.S	RXSYS	*M-RES
ROAT	F/S	*MENU-T

← →

+

Press

MENU 2

MENU 2	OF	
STSPD	DIAL	DTTRN
THSPD	SWTCH	MCLNK
ACCEL	TIMER	ADJST
START	LAP-L	THMOD
M-COP	SFRUN	UTRPA

BIGCAR

MENU 1	OF	
BRAKE	SUBTR	SYSTEM
A.B.S	REV	NAME
EPA	RXSYS	*M-SEL
STEXP	F/S	*M-RES
THXP		*MENU-T

← →

+

Press

MENU 2

MENU 2	OF	
STSPD	DIAL	DTTRN
THSPD	SWTCH	SERVO
ACCEL	PMIX1	ADJST
IDLUP	PMIX2	THMOD
M-COP	SFRUN	UTRPA

LEVEL3

MENU 1	2	
STEXP	EPA	TIMER
STSPD	ACCEL	LAP-L
THEXP	START	BOAT
THSPD	IDLUP	*M-SEL
BRAKE	PMIX1	*M-RES
A.B.S	PMIX2	*MENU-T

← →

+

Press

MENU 2

MENU 2	10	
SUBTR	DIAL	SYSTEM
REV	SWTCH	DTTRN
M-COP	D/R	MCLNK
NAME	ATL	ADJST
RXSYS	CH3/4	THMOD
F/S	SFRUN	UTRPA

Switch MENU1 and MENU2 by pressing the **+** button.

38

Menu Screen

The menu screen displays 18 items on 3 rows and 6 lines on one page and displays up to 36 items on 2 pages designated MENU1 and MENU2.

A menu screen matched to the purpose can also be created by using the menu customize functions described on page 40. The menu No. of the function indicated by the cursor is displayed at the top right-hand corner of the screen. When a function is not assigned, OF is displayed at the top right-hand corner of the screen.

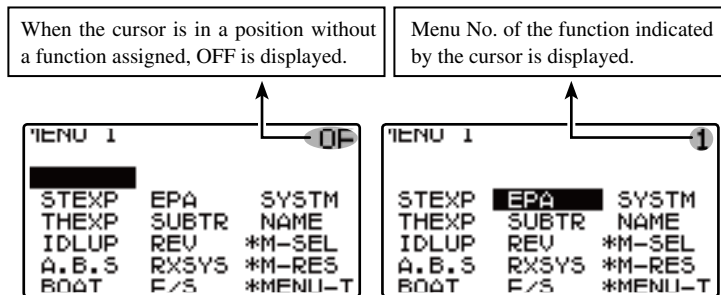

The screen above is an example of the LEVEL2 MENU1 menu.

Calling the setup screen

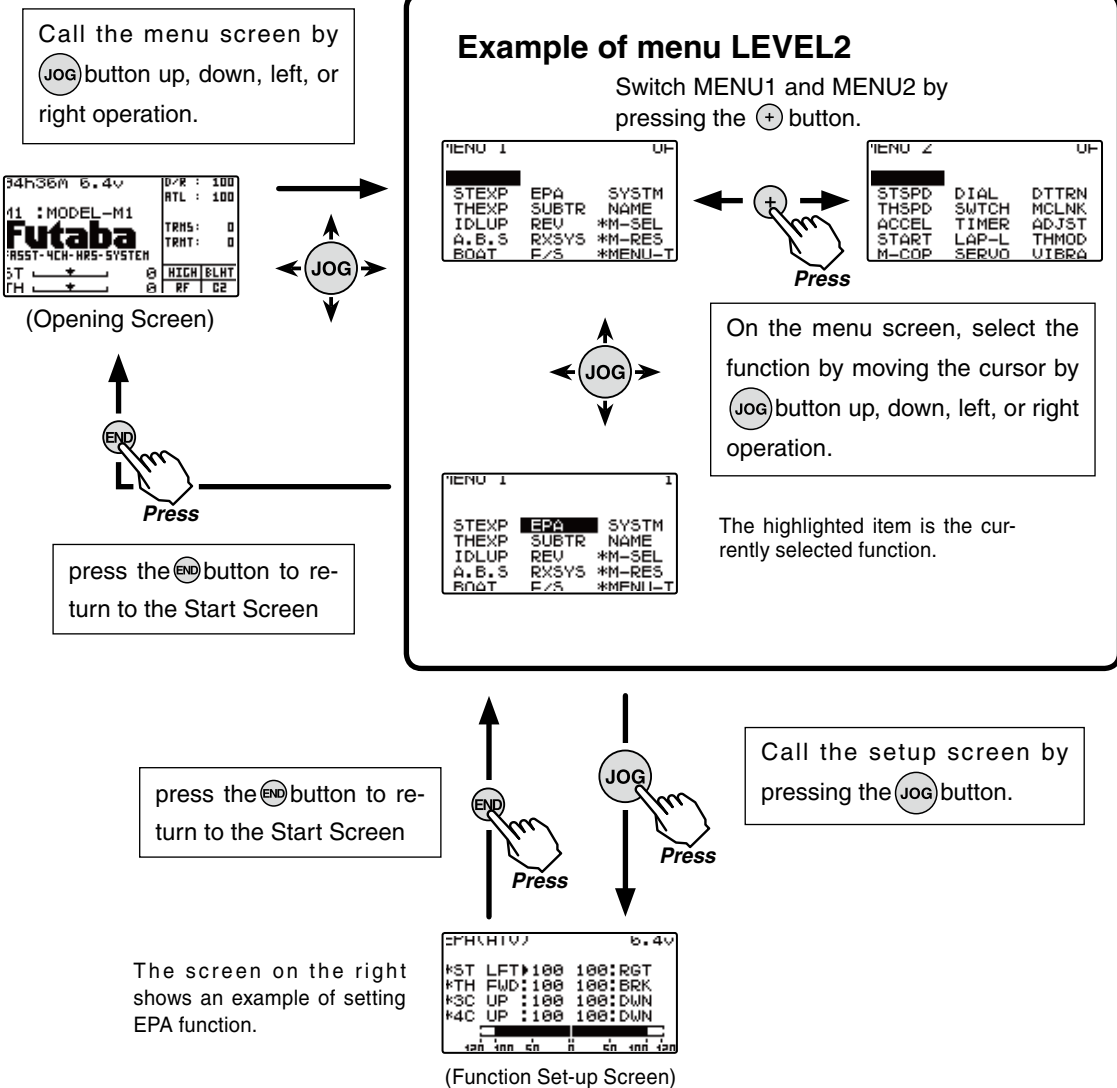

Function Map

Custom Menu

A menu matched to the purpose (custom menu) can be created by using the menu customize function.

A different menu can be created for each model memory.

In addition, custom menus can be copied to other models by using menu copy of the model copy function (page 100). There is a method which modifies the arrangement or adds (other than LEVEL3) or removes menus locally from the LEVEL1, LEVEL2, BIGCAR, and LEVEL3 basic menus and a method which changes all the menus to personal use only.

One point

This function allows modification of the menu list and addition (except LEVEL3) or removal of functions. All the functions can also be grouped at MENU1 only depending on the purpose.

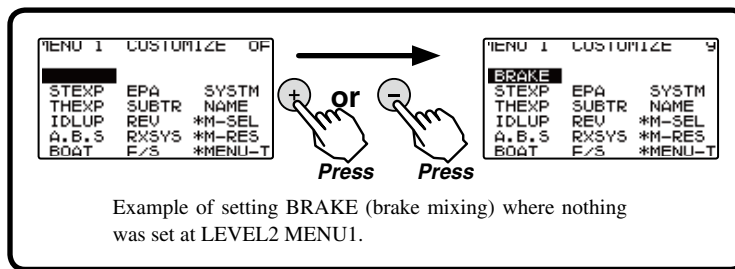

Menu assignment

- 1** Call the menu screen from the initial screen by (JOG) button up, down, left, or right operation.
- 2** Use the (+) button to Select the MENU1 or MENU2 screen to be edited.
- 3** Press the (-) button for about 1 second. A confirmation beep is generated and the menu customize screen is displayed.
- 4** Select the location where the function is to be assigned or modified by moving the cursor by (JOG) up, down, left, or right operation.
- 5** Use the (+) or (-) button to select the function to be assigned.
- 6** When assignment is complete, end by returning to the menu screen by pressing the (END) button.

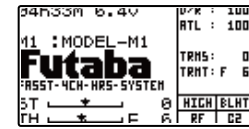

(Opening Screen)

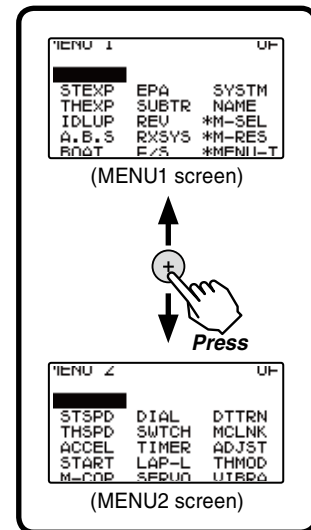
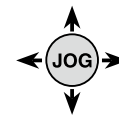

(approx. 1sec)

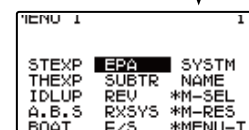
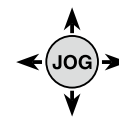
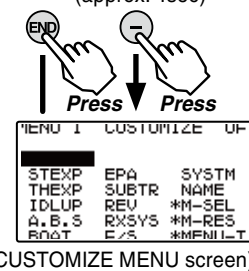

The highlighted item is the currently selected function.

Customizing all functions.

In addition to the menu types shown page 38, there is ALL-OFF. It is convenient when customizing all functions.

- 1** Call the menu screen from the initial screen by (JOG) button up, down, left, or right operation.
- 2** On the MENU1 screen, move the cursor to "*MENU-T" by (JOG) button up, down, left, or right operation and press the button.
- 3** (Menu type selection)
After the MENU TYPE screen is displayed, select the setting item "TYPE" with blinking cursor by (JOG) button up or down operation. Change "TYPE" by pressing (+) or (-) buttons. Example-select "ALLOFF".
- 4** (Menu type modification)
Select "EXEC" with blinking cursor by (JOG) button up or down operation. Press the (+) and (-) buttons simultaneously for 1 second.
- Operation is completed when "COMPLETE!" blinks on the screen.
- 5** Return to the menu screen by pressing the (END) button.
Use the (+) button to select the MENU1 or MENU2 menu screen to be edited.
- 6** Press the (-) button for about 1 second. A confirmation peeping sound is generated and the menu customize screen is displayed.
See steps 4 and 5 on page 40 for a description of the menu assignment method.

Note:

This function consists of 3 fixed functions; *M-SEL (model select), *M-RES (model reset), and *MENU-T (menu type select), and cannot be moved or deleted.

When the menu type is changed from the created customize menu to another menu type by *MENU-T, the customize menu is reset and the menu is initialized to the original menu.

The set values of a function deleted from the menu remain valid. When an unused function is turned OFF or rate adjustment, etc. related to other functions is performed, check the set values before deleting the function.

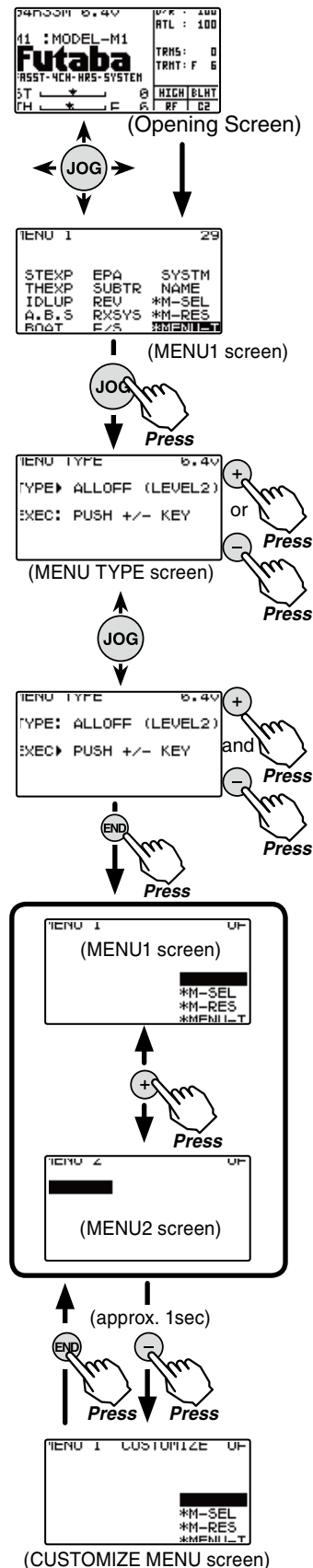

Direct Selection

The Direct Selection allows instant access to the six functions most frequently used. The function set-up screen can be directly and quickly called with the special buttons for each of the eight functions. They can be freely selected by pressing Direct Selection Button (DIR) function.

Initial Setting

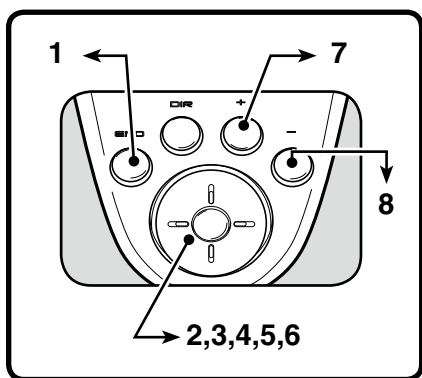
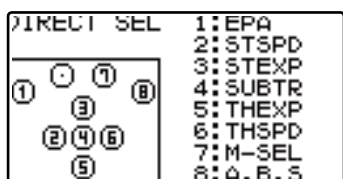

Direct No	Button	Function abbreviation	Function
1.	Press	EPA	Chanel End Point Adjuster
2.		STSPD	Steering Speed
3.		STEXP	Steering EXP
4.		SUBTR	Subtrim
5.		THEXP	Throttle EXP
6.		THSPD	Throttle Speed
7.	Press	M-SEL	Model Select
8.	Press	A.B.S	A.B.S

Function Map

Call the direct Selection screen by pressing the button.

Upon your needs, select one of the 8 functions and then click its button to call the Function Set-up Screen.

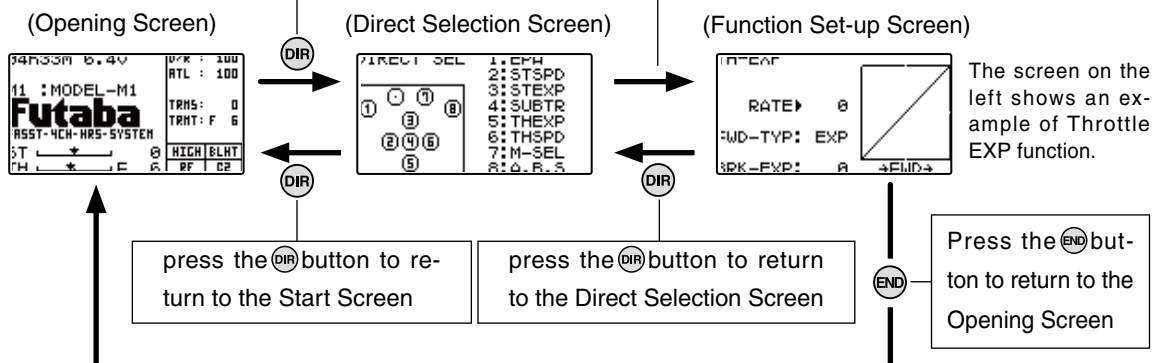

Direct Customize

With the T4PK, your favorite direct call matched to the purpose can be assigned to the edit buttons by using the direct customize function.

Direct call lets you create a different menu for each model memory.

Direct call assigned to each edit button can also be copied to other models by using menu copy of the model copy function (page 100).

Direct selection function assignment

- 1** The setup screen of this function is called by pressing the (DIR) button for 3 seconds or longer from the initial screen.
- 2** (Direct button selection)
Select the function you wish to customize (No.1~8) by (JOG) button up or down operation.
- 3** (Assignment function selection)
Change the function by pressing the (+) or (-) button.
- 4** When ending setting, return to the initial screen by pressing the (END) button and (DIR) button one time each, in that order.

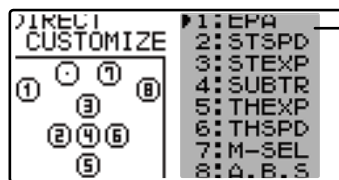
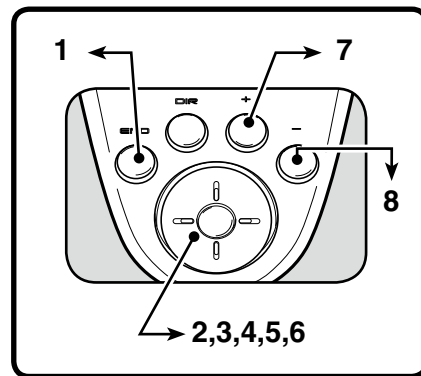

Setup items

- 1: Function assigned to button No. 1
- 2: Function assigned to button No. 2
- 3: Function assigned to button No. 3
- 4: Function assigned to button No. 4
- 5: Function assigned to button No. 5
- 6: Function assigned to button No. 6
- 7: Function assigned to button No. 7
- 8: Function assigned to button No. 8

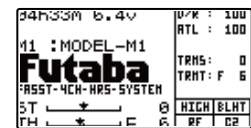

(Opening Screen)



3 seconds or longer

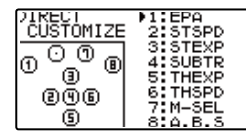

(Direct Customize Screen)

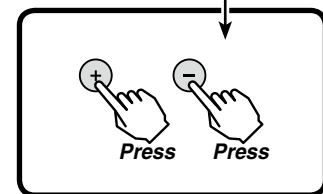
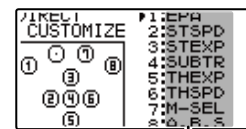
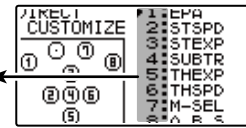

Function Map

List of functions by menu type

Function No	Function abbreviation	LEVEL1	LEVEL2 (Initial setting)	BIGCAR	LEVEL3
1	EPA	★	★	★	★
2	STEXP	★	★	★	★
3	STSPD		★	★	★
4	THEXP	★	★	★	★
5	THSPD		★	★	★
6	A.B.S	★	★	★	★
7	ACCEL		★	★	★
8	START		★		★
9	BRAKE			★	★
10	IDLUP		★	★	★
11	TIMER		★		★
12	LAP-L		★		★
13	PMIX1			★	★
14	PMIX2			★	★
15	BOAT	★	★		★
16	SUBTR	★	★	★	★
17	REV	★	★	★	★
18	F/S	★	★	★	★
19	*M-SEL	★	★	★	★
20	*M-RES	★	★	★	★
21	M-COP	★	★	★	★
22	NAME	★	★	★	★
23	DIAL	★	★	★	★
24	SWTCH	★	★	★	★
25	D/R				★
26	ATL				★
27	CH3/4				★
28	RXSYS	★	★	★	★
29	*MENU-T	★	★	★	★
30	SYSTEM	★	★	★	★
31	DTRN	★	★	★	★
32	SERVO		★	★	★
33	MCLNK	★	★		★
34	ADJST	★	★	★	★
35	VIBRA	★	★	★	★
36	THMOD	★	★	★	★

Function Map

Function list			
Function No	Function abbreviation	Description of function	Page No
1	EPA	End point adjustment	P-49
2	STEXP	Steering curve adjustment	P-56
3	STSPD	Steering servo delay	P-61
4	THEXP	Throttle curve adjustment	P-57
5	THSPD	Throttle servo delay	P-63
6	A.B.S	Pumping brake	P-69
7	ACCEL	Function which adjusts the rise characteristic from the throttle neutral position	P-52
8	START	Throttle preset at start function/ engine cut off by switch	P-66
9	BRAKE	Front and rear independent brake control for 1/5GP car, etc.	P-74
10	IDLUP	Idle up at engine start	P-82
11	TIMER	Up, down, lap, or lap navigation timer	P-90
12	LAP-L	Lap timer data (lap time, average lap time) check	P-97
13	PMIX1	Programmable mixing between arbitrary channels	P-83
14	PMIX2	Programmable mixing between arbitrary channels	P-83
15	BOAT	Boat, etc. brake operation stop/outboard engine tilt mixing	P-78
16	SUBTR	Servo center position fine adjustment	P-48
17	REV	Servo operation reversing	P-47
18	F/S	HRS, PCM mode fail safe, battery fail safe	P-54
19	*M-SEL	Model memory call	P-98
20	*M-RES	Model memory reset (ALL, DATA, MENU)	P-102
21	M-COP	Model memory copy (SINGLE, GROUP) (MENU, SW/DIAL)	P-100
22	NAME	Model memory name set/modify, username set/modify	P-99
23	DIAL	Selection of functions operated by digital dial and digital trim	P-88
24	SWTCH	Selection of functions operated by push switches	P-86
25	D/R	Steering angle adjustment while running	P-117
26	ATL	Brake side adjustment	P-118
27	CH3/4	Channel 3&4 servos operation position set/check	P-119
28	RXSYS	Servo response mode and receiver type selection	P-46
29	*MENU-T	Function menu type selection	P-103
30	SYSTEM	Battery type/backlight/LCD contrast/buzzer/LED display color/initial screen display mode/power off forgotten alarm/2ND condition/2.4GHz band adjustment and setting	P-108
31	DTTRN	Data copy from T4PK to another T4PK	P-112
32	SERVO	Displays servo operation on a bar graph	P-120
33	MCSLNK	MC850C/601C/401CR Link software setting function	P-104
34	ADJST	Steering wheel and throttle trigger correction	P-114
35	VIBRA	Vibrator setting	P-116
36	THMOD	Neutral brake and throttle servo forward side and brake side operation rate setting	P-80

Receiver Type / Servo Response Mode "RXSYS"

Receiver

There are two types of Futaba 2.4GHz receivers for cars depending on the system differences: C1 type and C2 type. The R603FS and 603FF are C1 type and the R604FS supplied with the 4PK set as standard is C2 type. For the R603FS and 603FF, set RX TYPE to "FASST-C1" and for the R604FS, set RX TYPE to "FASST-C2".

Servos

HIGH SPEED or NORMAL servo response mode can be selected. However, the HIGH SPEED mode is for Futaba digital servo (including BLS Series brushless servos) use only. When using another servo, select the NORMAL mode. All servos, including digital servos, can be used in the NORMAL mode.

Calling the setup screen

*Calling from menu screen

(Opening Screen)

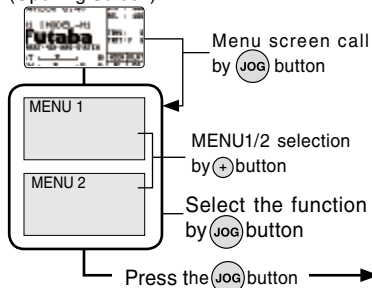

* When the direct call button is set, the setup screen is also called by the following method:

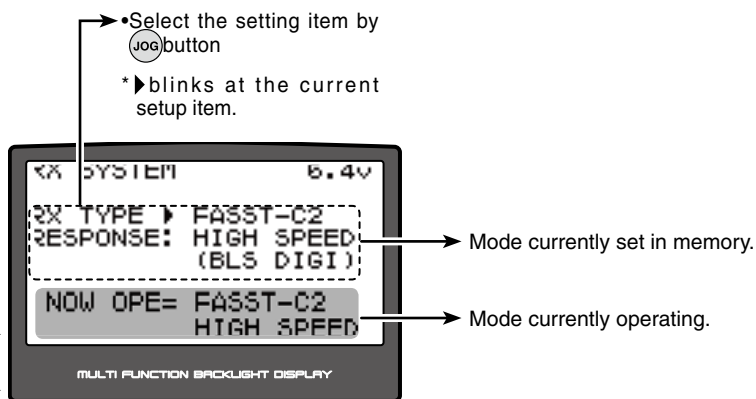
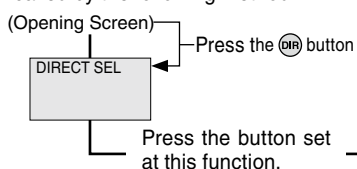

- When the receiver type and servo response was changed and when a model of a different receiver type and servo response was selected, turn the transmitter power off and on. Radio waves are output by the type set at that point.

Rx type / Servo response mode selection

(Preparation)

Select the item to be set by (JOG) button up or down operation.

1 (Writing to memory)

Press the (+) or (-) button and set the RX TYPE or RESPONSE.

2 In order the change to occur you need to cycle the power (off/on) to make the change successful.

RX TYPE / RESPONSE selection

- Select by (JOG) button left or right operation.

RX TYPE

FASST-C1, FASST-C2

RESPONSE

HIGH SPEED (BLS DIGI)

NORMAL (GENERAL)

Select button

- Select with the (+) or (-) buttons.

Servo Reverse "REV"

(All channel)

This function reverses the direction of operation of the servos related to transmitter steering, throttle, and channel 3 operation.

However, when the position set by trim or subtrim shifts from the center, the center becomes the opposite side.

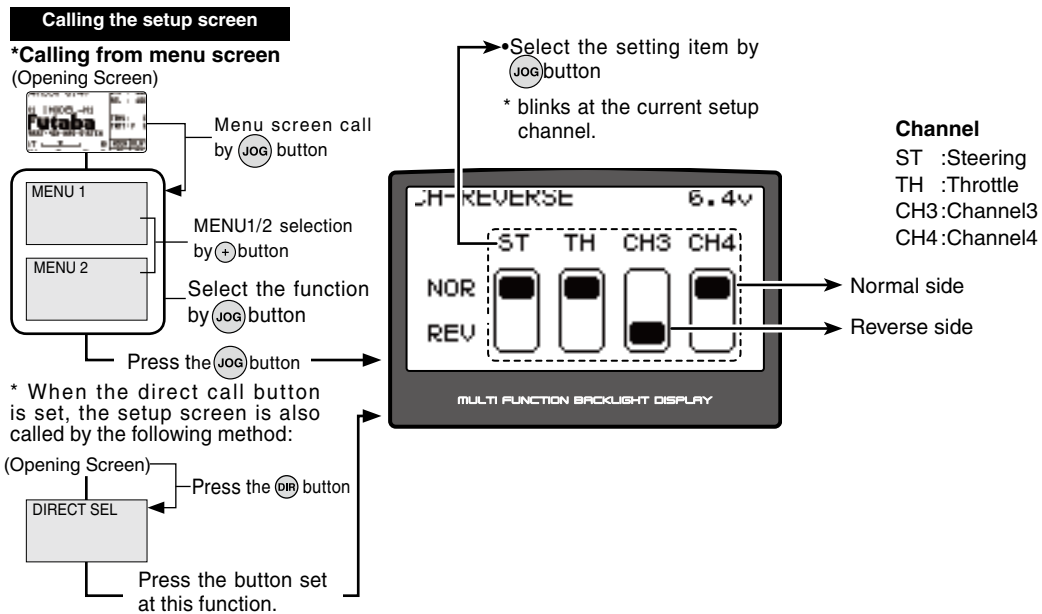

Servo Reverse Function Setting

(Preparation)

Select the channel to be set by (JOG) button left or right operation. ST, TH, and CH3 on the screen blink.

1 (Servo reverse setting)

Use the (+) or (-) button to reverse the servo operation direction.

(Each channel can be set similarly.)

2 When ending setting, return to the initial screen by pressing the (END) button twice (for function menu screen, press the (END) button once).

Channel selection

- Select by (JOG) button left or right operation.

Select button

- Select with the (+) or (-) buttons.

Function

Subtrim "SUBTR"

(All channel)

Use this function to adjust the neutral position of the steering, throttle, channel 3 and channel 4 servos.

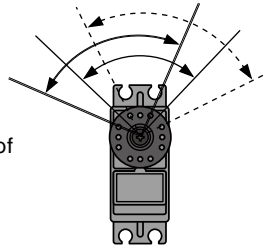

*Subtrim adjusts the entire range of the servo in the set direction.

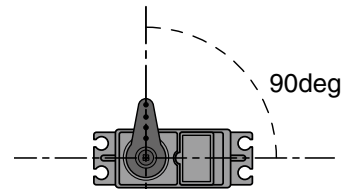

Use to adjust the neutral position

Calling the setup screen

*Calling from menu screen
(Opening Screen)

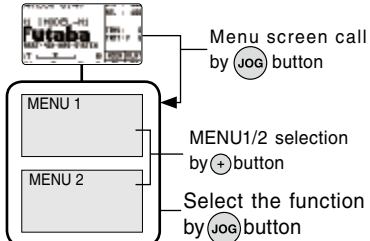

Press the (JOG) button

* When the direct call button is set, the setup screen is also called by the following method:

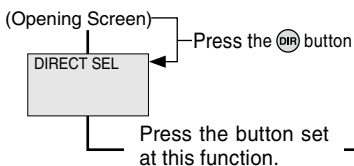

Press the button set at this function.

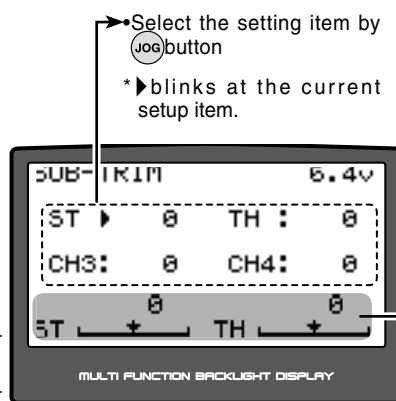

Select the setting item by (JOG) button

* blinks at the current setup item.

Channel

ST :Steering
TH :Throttle
CH3 :Channel 3
CH4 :Channel 4

Set the steering and throttle digital trims to the neutral "0" position.

Brake side operation stop method

(Preparation)

- Set the steering and throttle digital trims to the neutral "0" position. Set CH3 to the center "0" position.
- Select the channel to be set by (JOG) button up or down operation.

1 (Subtrim adjustment)

Use the (+) or (-) button to adjust the center.

(Each channel can be set similarly.)

2 When ending setting, return to the initial screen by pressing the (END) button twice (for function menu screen, press the (END) button once).

Channel selection

- Select by (JOG) button up or down operation.

Adjust button

- Adjust with the (+) and (-) buttons.
- Return to the initial value "0" by pressing the (+) and (-) buttons simultaneously for about 1 second.

Subtrim

ST :L100~R100
TH :B100~F100
CH3 :-100~+100
CH4 :-100~+100
Initial value : 0

End Point Adjuster "EPA"

(All channel)

Use this when performing left and right end point adjustments, throttle high side/brake side operation amount adjustment, channel 3 and channel 4 servo up side/down side operation amount adjustment during linkage.

- Correct the maximum steering angle for left and right steering angles when there is a difference in the turning radius due to the characteristics, etc. of the vehicle.

Maximum steering angle

The EPA function basically determines the maximum steering angle of each channel. The functions shown below may have been adjusted or the operating range set by EPA function may be exceeded. Check the linkage each time the following functions are adjusted.

- Sub trim (all channels)
- Program mixing slave side (all channels)
- Tilt mixing (steering, channel 3)
- Idle up (throttle)
- Start Function, Engine Cut (throttle)
- Throttle acceleration (throttle)

ATL trim

ATL trim allows adjustment of the brake side operation amount during operation. Therefore, when the operating angle is adjusted with throttle EPA, ATL trim must also be taken into account.

Remark

When the steering angle is insufficient even though EPA is increased to maximum (120%), the steering angle can be increased somewhat by using program mixing. (Setup example: See page 85.)

⚠ Warning

- ❗ Operate each servo over its full stroke and be sure the linkage does not bind or is not loose.

The continuous application of unreasonable force to a servo may cause damage and excessive battery drain.

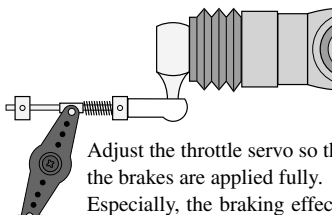

Adjust the throttle servo so that unreasonable force is not applied when the engine carburetor is full open, full closed, and the brakes are applied fully.

Especially, the braking effect becomes poor by heating of the brakes while running. Before running, adjust the suitable maximum servo travel so that unreasonable force is not applied even when the servo travel is increased while running.

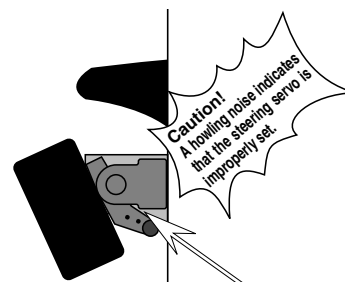

Decide the EPA value at the contact point.

Adjust the steering servo so that unreasonable force is not applied to the servo by the chassis at maximum servo travel.

Function

Calling the setup screen

*Calling from menu screen (Opening Screen)

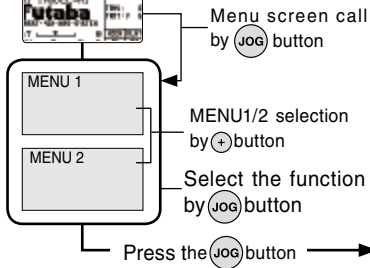

* When the direct call button is set, the setup screen is also called by the following method:

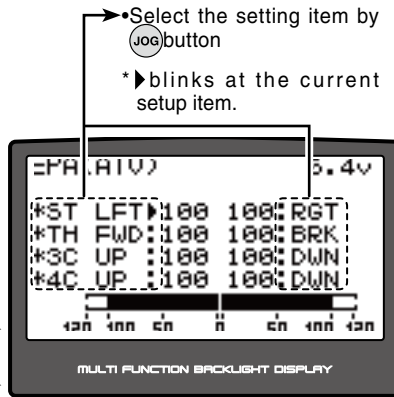
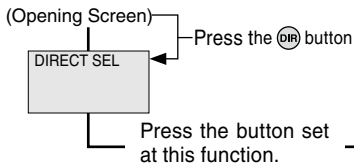

Select the setting item by (JOG) button

* blinks at the current setup item.

Setting item (channel and direction)

- ST-LFT :Steering (left side)
- ST-RGT :Steering (right side)
- TH-FWD :Throttle (forward side)
- TH-BRK :Throttle (brake side)
- 3C-UP :3rd channel (up side)
- 3C-DWN :3rd channel (down side)
- 4C-UP :4th channel (up side)
- 4C-DWN :4th channel (down side)

Setting item selection (channel and direction)

- Select by (JOG) button left or right operation.
- The direction (ST-LFT and ST-RGT) linked with the steering wheel is switched.
- The direction (TH-FWD and TH-BRK) linked with the throttle trigger is switched.

Steering (EPA) adjustment

(Preparation)

- Before setup of the steering end point adjustment (EPA), set the steering D/R dial (initial setup: DL1) to the maximum steering angle position 100%.
- Select the setting item "ST-LFT" by (JOG) button up or down operation and make the following adjustments:

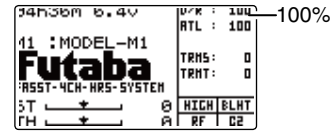

1 Steering (left side) adjustment

Turn the steering wheel fully to the left and use the (+) or (-) buttons to adjust the steering angle.

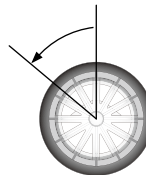

2 Steering (right side) adjustment

Turn the steering wheel fully to the right and use the (+) or (-) buttons to adjust the steering angle.

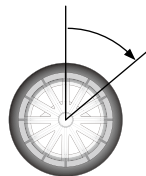

3 When adjusting the steering angle of another channel immediately after this, see the adjustment method for that channel. When ending setting, return to the initial screen by pressing the (END) button twice (for function menu screen, press the (END) button once).

Adjust button

- Adjust with the (+) and (-) buttons.
- Return to the initial value "100" by pressing the (+) and (-) buttons simultaneously for about 1 second.

Note

Step #1 & #2 are done when the receiver is in the on position installed on the chassis. You're watching the wheel reach their maximum end point.

Steering EPA

- ST-LFT :0~120
- ST-RGT :0~120
- Initial value :100

Throttle (EPA) adjustment

(Preparation)

- Before setting the throttle end point adjustment(EPA), set the throttle ATL dial (initial setup: DL2) to the maximum throttle angle position 100%.
- Select the setting item "TH-FWD" by (JOG) button up or down operation and make the following adjustments:

1 Throttle (forward side) adjustment

Pull the throttle trigger fully to the high side and use the (+) or (-) buttons to adjust the throttle angle. However, when using an FET amp, set to 100%.



2 Throttle (brake side/reverse side) adjustment

Move the throttle trigger fully to the brake side and use the (+) or (-) buttons to adjust the throttle angle. However, when using an ECS, set to 100%.



- ### 3
- When adjusting the throttle angle of another channel immediately after this, see the adjustment method for that channel. When ending setting, return to the initial screen by pressing the (END) button twice (for function menu screen, press the (END) button once).

If "CUT OFF", (which prohibits trigger brake side operation in the boat mode (p.78)), is set, throttle "TH-BRK" (brake side) cannot be adjusted.

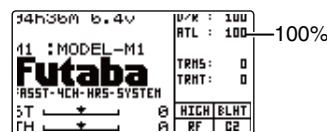

Adjust button

- Use the (+) and (-) buttons to make adjustments.
- Return to the initial value "100" by pressing the (+) and (-) buttons simultaneously for about 1 second.
- Please see previous note on page 50.

Throttle EPA

TH-FWD :0~120
TH-BRK :0~120
Initial value :100

3rd & 4th channel servo (EPA) adjustment

(Preparation)

- Select the setting item "3C-UP" or "4C-UP" by (JOG) button up or down operation and make the following adjustments:

1 3rd/4th channel servo (up side) adjustment

Set the 3rd or 4th channel dial fully to the up side (+ side) and use the (+) or (-) buttons to adjust the servo angle.

2 3rd/4th channel servo (down side) adjustment

Select the setting item "3C-DWN" or "4C-DWN" by (JOG) button up or down operation and set the 3rd or 4th channel dial fully to the down side (-) and use the (+) or (-) buttons to adjust the servo angle.

- ### 3
- When adjusting the servo angle of another channel immediately after this, see the adjustment method for that channel. When ending setting, return to the initial screen by pressing the (END) button twice (for function menu screen, press the (END) button once).

Direction selection

- Select by (JOG) button up or down operation.

Adjust button

- Adjust with the (+) and (-) buttons.
- Return to the initial value "100" by pressing the (+) and (-) buttons simultaneously for about 1 second.
- Please see previous note on page 50.

3rd & 4th channel EPA

3/4C-UP :0~120
3/4C-DWN :0~120
Initial value :100

Throttle Acceleration "ACCEL"

(Throttle system)

The servo will jump to the input position at its maximum possible speed. Unlike exponential, which adjusts the whole throttle movement into a curve, throttle acceleration simply "jumps" away from neutral and then leaves the remaining response linear.

Operation

- Operation near the throttle trigger neutral position becomes a sharp rise.
- The forward and brake sides can be set separately.
- When the brake mixing function (p.74) is set, the CH3/CH4 brake can also be set.

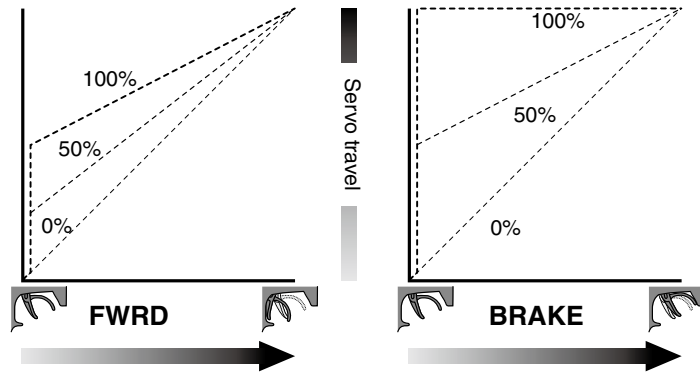

Set value

The standard value (100% point) of this setup affects the operation amount set by throttle EPA function.

Convenient usage method

For gasoline engine cars, the linkage must have a clearance because one servo controls the engine carburetor and brake. Thus, there is a noticeable time delay at both the forward and brake sides. Sharp response comparable to that of electric motor cars is obtained by reducing this clearance at the transmitter side.

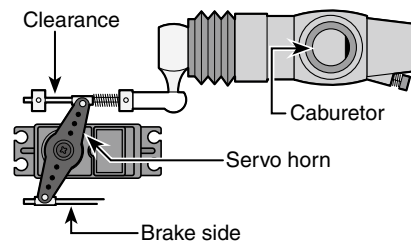

Calling the setup screen

*Calling from menu screen
(Opening Screen)

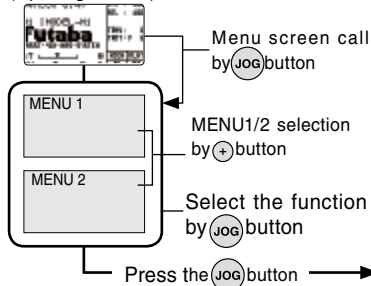

* When the direct call button is set, the setup screen is also called by the following method:

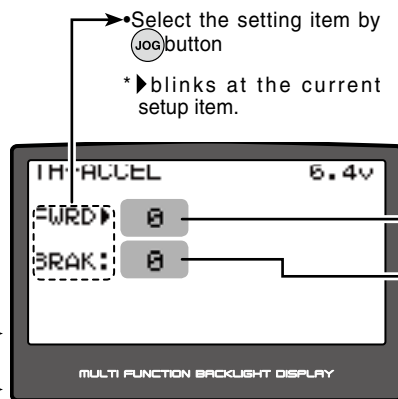
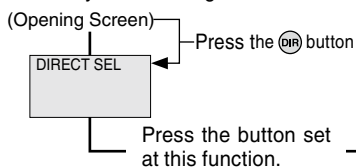

Setup item

- FWRD :Forward side acceleration amount
- BRAK :Brake side acceleration amount

Setting item selection

- Select by (JOG) button up or down operation.

Function

Throttle acceleration adjustment

(Preparation)

- Select the setting item "FWRD" by (JOG) button up or down operation and make the following adjustments:

1 (Forward acceleration amount adjustment)

Use the (+) and (-) buttons to adjust the acceleration amount.

"0" :No acceleration

"100" :Maximum acceleration (Approximately 1/2 of the forward side throttle angle)

2 (Brake side acceleration amount adjustment)

Select the setting item "BRAK" by (JOG) button up or down operation and use the (+) and (-) buttons to adjust the acceleration amount.

"0" :No acceleration

"100" :Maximum acceleration (Brake side maximum throttle angle)

3 (3rd & 4th channel brake side acceleration amount adjustment)

If the "Brake Mixing Function" (see page 74) is being set, the 3rd or 4th channel brake side acceleration will become adjustable.

Select the setting item "BRAK (3CH)" or "BRAK (4CH)" by (JOG) button up or down operation and adjust acceleration amount by (+) or (-) button.

"0" :No acceleration

"100" :Maximum acceleration (Brake side maximum throttle angle)

- ### 4
- When ending setting, return to the initial screen by pressing the (END) button twice (for function menu screen, press the (END) button once).

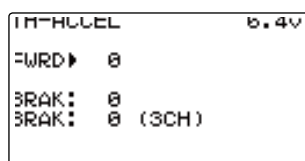

3rd channel Brake

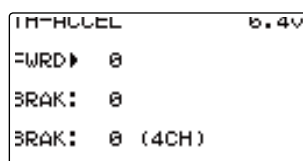

4th channel Brake

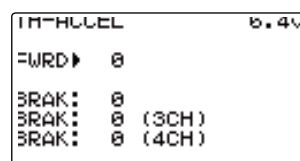

3rd & 4th channel Brake

Caution

When "TRG-BRK" is set to "CUT OFF" by boat mode function (p.78), the brake side function is not activated.

Dial / Trim Setting

The throttle acceleration adjustment amount (FOWRD), (BRAKE), 3rd channel (BRAKE 3CH) and 4th channel (BRAKE 4CH) can be controlled with digital dial DL1, DL2, DL3 or digital trim DT3 etc. with the function select dial function. (p.88)

Adjust button

Adjust with the (+) and (-) buttons.

- Return to the initial value "0" by pressing the (+) and (-) buttons simultaneously for about 1 second.

Forward acceleration amount (FWRD)

0~100

Initial value: 0

Brake side acceleration amount (BRAK)

0~100

Initial value: 0

3rd/4th channel brake side acceleration amount (BRAK 3CH),(BRAK 4CH)

0~100

Initial value: 0

Fail Safe/Battery Fail Safe Function "F/S" (All channel)

Fail Safe Mode (F/S)

This function moves each servo to a preset position when the receiver cannot receive the signals from the transmitter for some reason.

-When "Rx Type"(p.46) is set "FASST-C1" and "Servo Response"(p.46) is "NORMAL", the setting fail safe (F/S) is only throttle (TH). Other channels are in "OFF" mode.

-The fail safe data is transferred from the transmitter to the receiver 10 seconds after the transmitter power is turned on and every minute thereafter. Usually the power is turned on in transmitter and then receiver order. Therefore, data is not transferred for about 1 minute after the receiver power is turned on.

-For gasoline engine cars, for safety we recommend that this fail safe function be used to set the throttle channel in the direction in which the brakes are applied.



**"AUTO TRANSFER" blinks during data transfer.

Hold mode (HOLD)

This function holds the receiver in its position immediately before reception was lost. It is an R604FS and other C2 type receiver only function. When the receiver used is the R603FF/FF C1 type, this function cannot be used because the receiver type is set to "FASST-C1" by receiver type setting (p.46).

Off mode (OFF)

This function stops output of signals to the servos and places the servos into the free state when the receiver cannot receive.

The F/S, HOLD, and OFF modes are automatically reset when signals from the transmitter can be received again.

Battery fail safe function (BATT-F/S)

When the receiver battery voltage drops below a certain value when this function is enabled, the throttle servo moves to the position set by fail safe function. When the battery voltage recovers, the battery fail safe function is automatically reset.

-This function cannot be used when the throttle (TH) is not set to fail safe (F/S).

-For an R603FS/FF with RX TYPE (page 46) set to C1 types "FASST-C1", when throttle (TH) is set to fail safe (F/S), the battery fail safe function is executed automatically. It cannot be set at the transmitter.

Function

Calling the setup screen

*Calling from menu screen
(Opening Screen)

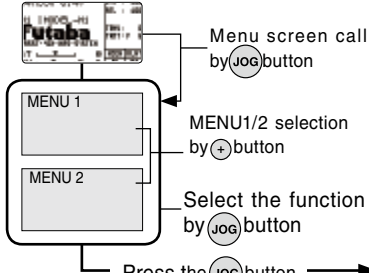

* When the direct call button is set, the setup screen is also called by the following method:

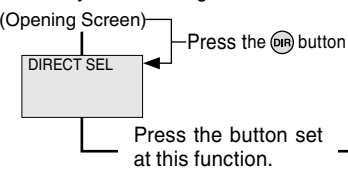

*Select the setting item by JOG button
*blinks at the current setup item.

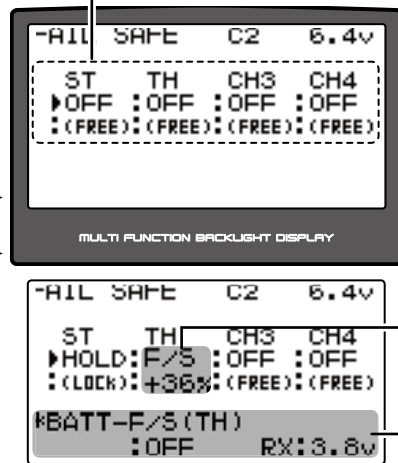

Setup item

ST :Steering
TH :Throttle
CH3 :Channel3
CH4 :Channel4
MODE :Battery fail safe function ON/OFF

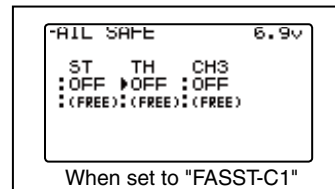

* When fail safe is set, that servo position is displayed.

* When fail safe is set at throttle (TH), the battery fail safe (BATT-F/S) setting items are displayed.

Fail safe mode selection

(Preparation)

- Select the channel to be set by (JOG) button operation.

- 1** (Mode selection)
Select the mode by (+) or (-) button.
(Each channel can be individually set.)

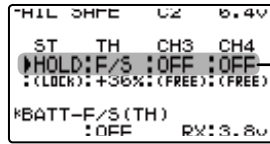

Setup item selection

- Select by (JOG) button up or down operation.

F/S mode selection

- Select with the (+) or (-) buttons.

F/S mode

OFF, HOLD, F/S

- 2** When ending hold or off mode setting, return to the initial screen by pressing the (END) button twice (for function menu screen, press the (END) button once). When setting fail safe, set the servo position by the following method.

Fail safe function setup

- 1** (Servo position setup)

When the fail safe function operates, the steering wheel, the throttle trigger or 3rd channel dial remains in the desired operation position. When the (+) and (-) buttons are pressed simultaneously for about 1 second, the servo position is displayed and you can confirm that the function was set.

When you want to release the setting, press the (+) or (-) button for 1 second. "HOLD" is displayed.

(Each channel can be set similarly.)

- 2** When ending setting, return to the initial screen by pressing the (END) button twice (for function menu screen, press the (END) button once).

F/S position setup button

- The (+) and (-) buttons are pressed simultaneously for about 1 second.

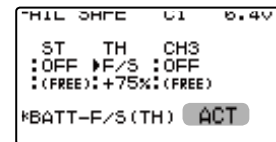

When RX TYPE is set to "FASST-C1", the BATT-F/S function automatically becomes "ACT"(active).

Battery fail safe function ON/OFF & BATT-F/S voltage setting

(Preparation)

- Select the setting item by (JOG) button operation. For BATT-F/S function ON/OFF, select "OFF" or "ACT" of "BATT-F/S(TH)". For voltage setting, select RX**V (3.5V, 3.8V, 4.4V, 4.75V).

- 1** (Battery fail safe function ACT/OFF)
BATT-F/S function ACT/OFF and voltage setting which activates the BATT-F/S function can be switched by (+) or (-) button.

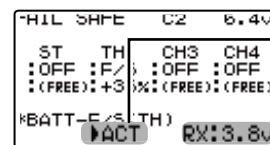

Battery fail safe function

OFF, ON
Initial value: OFF

BATT-F/S Voltage

3.5v, 3.8v, 4.4v, 4.75v
Initial value 3.8v

- 2** When ending setting, return to the initial screen by pressing the (END) button twice (for function menu screen, press the (END) button once).

When the receiver power supply of an electric car uses a common power supply from an ESC, we recommend that this function be set to OFF because the voltage supplied to the receiver may drop momentarily and the battery fail safe function may be activated.

Steering EXP "STEXP"

(Steering system)

This function is used to change the sensitivity of the steering servo around the neutral position. It has no effect on the maximum servo travel.

Racers Tip

When the setting is not determined, or the characteristics of the model are unknown, start with 0%. (When EXP is set to 0%, servo movement is linear.)

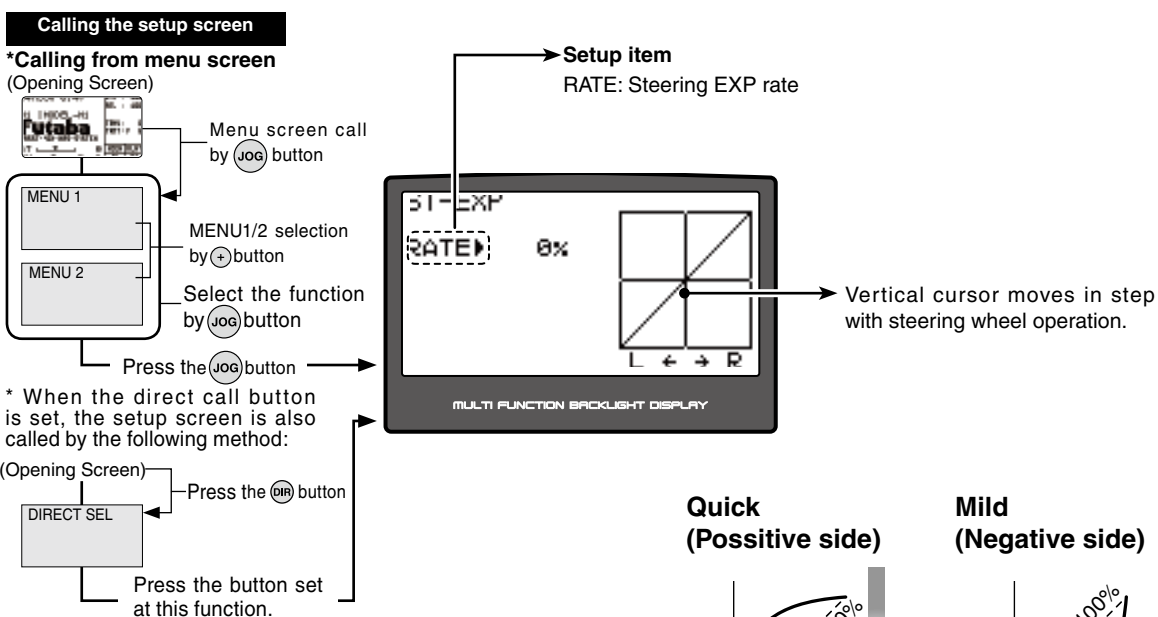

Dial / Trim Setting

The steering EXP adjustment (RATE) can be controlled with with digital dial DL1, DL2, DL3 or digital trim DT3 etc. with the function select dial function. (See page 88)

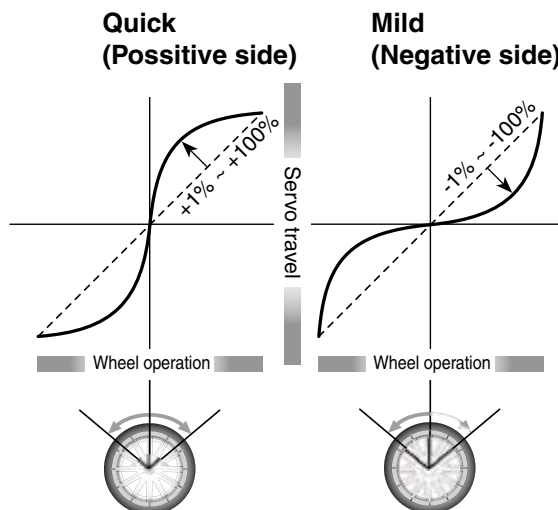

Steering EXP adjustment

- 1** When you want to quicken steering operation, use the (+) button to adjust the + side. When you want to make steering operation milder, use the (-) button to adjust the - side.
- 2** When ending setting, return to the initial screen by pressing the (END) button twice (for function menu screen, press the (END) button once).

Adjustment range

-100~0~+100%

Adjust button

Adjust with the (+) and (-) buttons.
- Return to the initial value "0" by pressing the (+) and (-) buttons simultaneously for about 1 second.

Throttle EXP "THEXP"

(Throttle system)

This function makes the throttle high side and brake side direction servo operation quicker or milder. It has no effect on the servo maximum operation amount.

For the high side, selection from among three kinds of curves (EXP/VTR/CRV) is also possible.

Advice

When the course conditions are good and the surface has good grip, set each curve to the + side (quick side). When the road surface is slippery and the drive wheels do not grip it, set each curve to the - minus (mild) side.

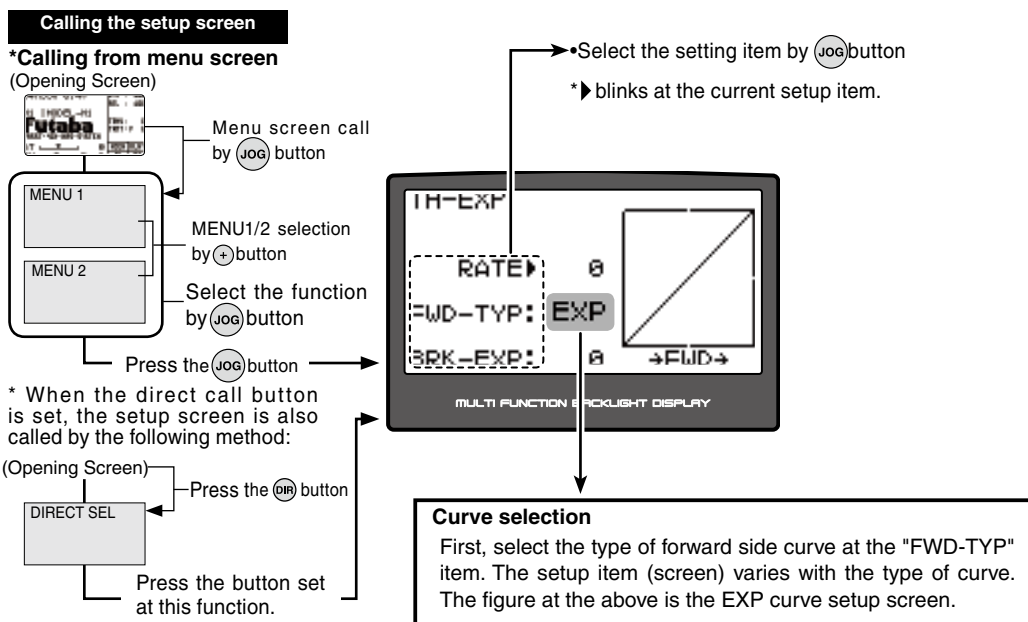

Curve selection

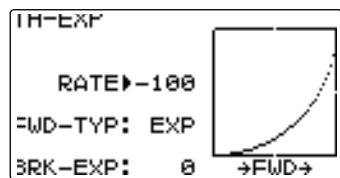

(EXP curve screen)

Curve type which operates the throttle from the neutral point to the high point on a curved curve.

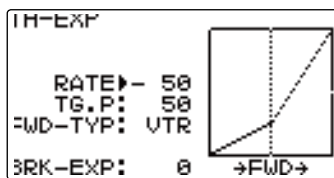

(VTR curve screen)

Curve type which sets the switching point between the throttle neutral point and high point and operates the throttle on a linear curve.

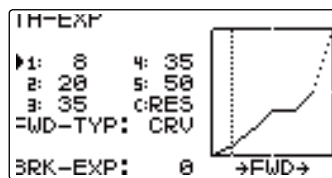

(CRV curve screen)

Curve type which sets 5 points between the throttle neutral point and high point and operates the throttle.

Caution

When "TRG-BRK" is set to "CUT OFF" by boat mode function (page 78), the brake side function is not activated.

Dial / Trim Setting

The throttle EXP curve and VTR curve adjustment (Forward side RATE) and (Brake side RATE) can be controlled with digital dial DL1, DL2, DL3 or digital trim DT3 etc. with the function select dial function. (See page 88)

Function

Adjustment method for EXP curve

(Preparation)

- With the jog dial, move the blinking cursor up or down to select "FWD-TYP".

With the plus (+) or minus (-) buttons, select EXP.

- With the jog dial, move the blinking cursor up or down to select "RATE" and make the following preferred settings.

Setup items

RATE :Forward side rate
 FWD-TYP :Forward side curve selection
 BRK-EXP :Brake side rate

Setup item selection

- Select by (JOG) button up or down operation.

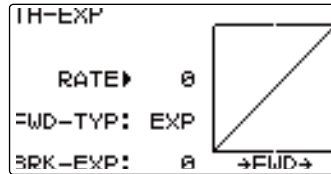

Curve type Select button

- Select with the (+) or (-) buttons.

1 Forward Exponential Adjustment

Use the plus (+) button to adjust for a faster throttle response or use the minus (-) button for a slower or milder throttle response.

- Plus (+) button- the higher the number goes on the positive side, the faster the response will be at center of throttle response.

- Minus (-) button- the higher the number goes on the negative side, the milder or softer it is in the center of the throttle response.

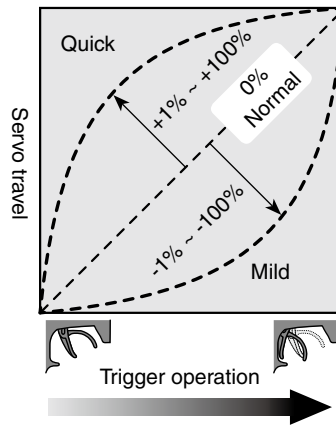

Adjustment range

RATE :-100 ~ 0 ~ +100%
 FWD-TYP :EXP, VTR, CRV
 BRK-EXP :-100 ~ 0 ~ +100%

Adjust button

Adjust with the (+) and (-) buttons.

- Return to the initial value "0" by pressing the (+) and (-) buttons simultaneously for about 1 second.

2 Brake Exponential Adjustment

With the jog dial, move the blinking cursor up or down to select "BRK-EXP".

Use the plus (+) button to adjust for a faster brake response or use the minus (-) button for a slower or milder brake response.

- Plus (+) button- the higher the number goes on the positive side, the faster the response will be at center of brake response.

- Minus (-) button- the higher the number goes on the negative side, the milder or softer it is in the center of the brake response.

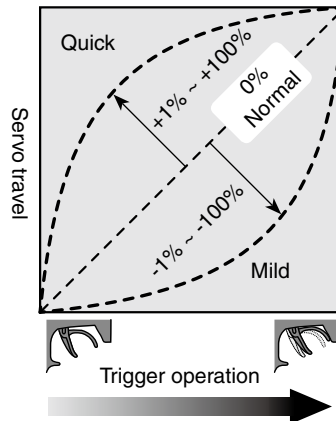

3 When ending setting, return to the initial screen by pressing the (END) button twice (for function menu screen, press the (END) button once).

Throttle EXP "THEXP"

Adjustment method for VTR curve

(Preparation)

- With jog dial, move the blinking cursor up or down to select "FWD-TYP". Use the plus (+) or minus (-) keys to select "VTR".
- With the jog dial, move the blinking cursor up or down to select "RATE" and make the following adjustments:

Setup items

RATE :Forward side rate
 TG.P :Curve switching point
 FWD-TYP :Forward side curve selection
 BRK-EXP :Brake side rate

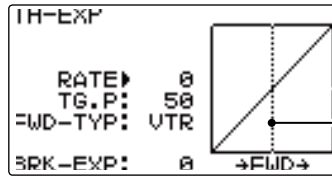

Switching point

A vertical cursor line that shows the curve switching point is displayed on the setup screen graph.

Setup item selection

- Select by (JOG) button up or down operation.

1 Forward side adjustment

Use the plus (+) button to adjust for a faster response. Use the minus (-) button for a slower or mild response.

-Plus (+) button- the higher the number goes on the positive side, the faster the response will be at center of throttle response.

-Minus (-) button- the higher the number goes on the negative side, the milder or softer it is in the center of the throttle response.

Adjustment range

RATE :-100 ~ 0 ~ +100%
 FWD-TYP :EXP, VTR, CRV
 TG.P :20 ~ 80%
 BRK-EXP :-100 ~ 0 ~ +100%

Adjust buttons

Adjust with the (+) and (-) buttons.

- Return to the initial value by pressing the (+) and (-) buttons simultaneously (approx. 1 sec).

2 Curve switching point adjustment

With the jog dial, move the blinking cursor up or down to select "TG.P". Use the plus (+) or minus (-) buttons to move the point you prefer. This gives you the opportunity of switching the curve point in relative to the throttle trigger position.

Initial value:

RATE and BRK-EXP "0"
 TG.P "50"

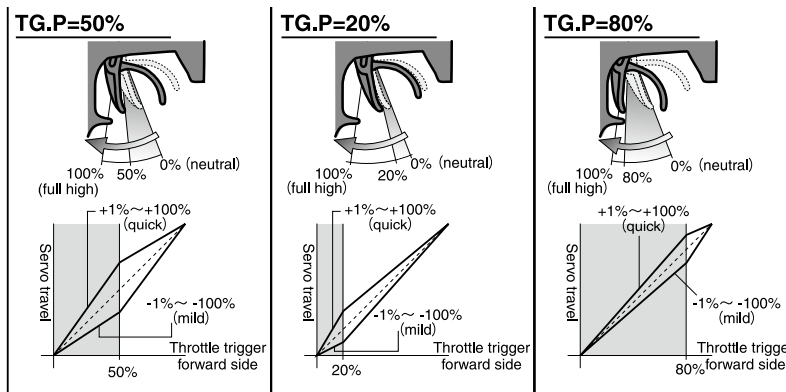

3 Brake side adjustment

With the jog dial, move the blinking cursor up or down to select "BRK-EXP". Use the plus (+) button to adjust for a faster brake response or use the minus (-) button for a slower or milder brake response.

For the VTR curve, only the high side can be set. The brake becomes the EXP curve.

- ## 4
- When ending setting, return to the initial screen by pressing the (END) button twice (for function menu screen, press the (END) button once).



Adjustment method for VTR curve

(Preparation)

- Select "CRV" at setup item "FWD-TYP".

Setup items

1:~5 :Curve points 1~5
 C:RES :Curve reset
 FWD-TYP :Forward side curve selection
 BRK-EXP :Brake side rate

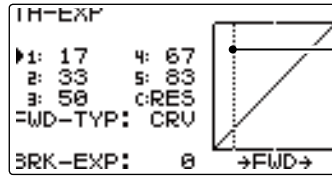

Curve type Select button

- Select with the (+) or (-) buttons.

Point in current setup

A vertical cursor line that shows the point in the current setup is displayed on the setup screen graph.

Setup item selection

- Select by (JOG) button up, down, left or right operation.

Adjustment range

1: ~ 5 : 0 ~ 100%
 F-TYP : EXP, VTR, CRV
 BRAKE: -100 ~ 0 ~ +100%

Adjust buttons

Adjust with the (+) and (-) buttons.

- Return to the initial value by pressing the (+) and (-) buttons simultaneously (approx. 1 sec).

Initial value:

Point.1:17, 2:33, 3:50, 4:67, 5:83
 BRK-EXP "0"

Returning entire curve to initial value

- Select setup item "C:RES" and return the set value of each point to the initial value by simultaneously pressing (approx. 1 sec) the (+) and (-) buttons.

1 Curve setup

- Select the setting item "1:" (1st point), by (JOG) button up, down, left, or right operation, and use the (+) and (-) buttons to set the 1st point.

Set the throttle curve by sequentially setting "2:" (2nd point) ~ "5:" (5th point).

2 Brake side adjustment

Select the setting item "BRAKE" by (JOG) button up or down operation. When you want to quicken the rise, use the (+) button to adjust the + side and when you want to make the rise milder, use the (-) button to adjust the - side.

3 When ending setting, return to the initial screen by pressing the (END) button twice (for function menu screen, press the (END) button once).

For the CRV curve, only the high side can be set. The brake becomes the EXP curve.

Throttle curve

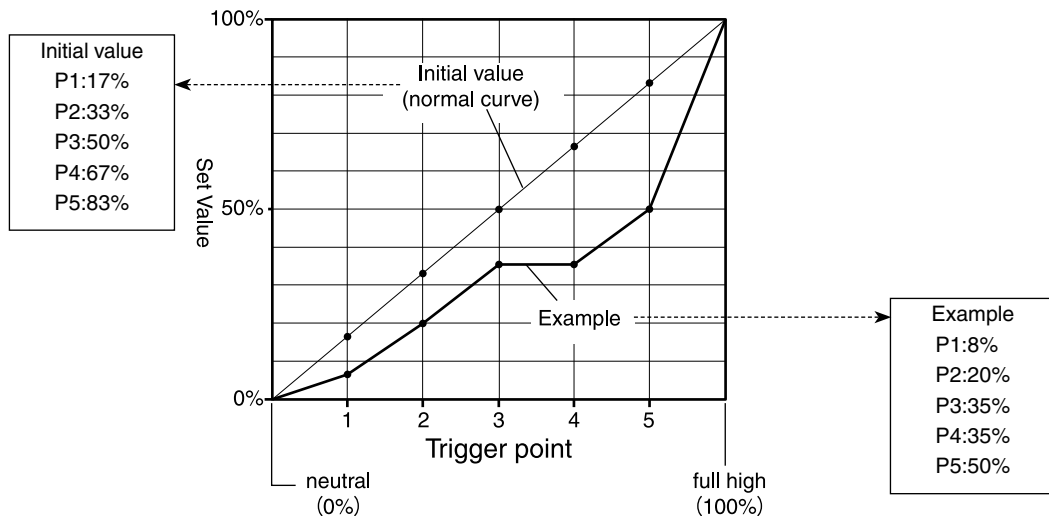

Steering Speed "STSPD"

(Steering system)

Quick steering operation will cause momentary understeering, loss of speed, or spinning. This function is effective in such cases.

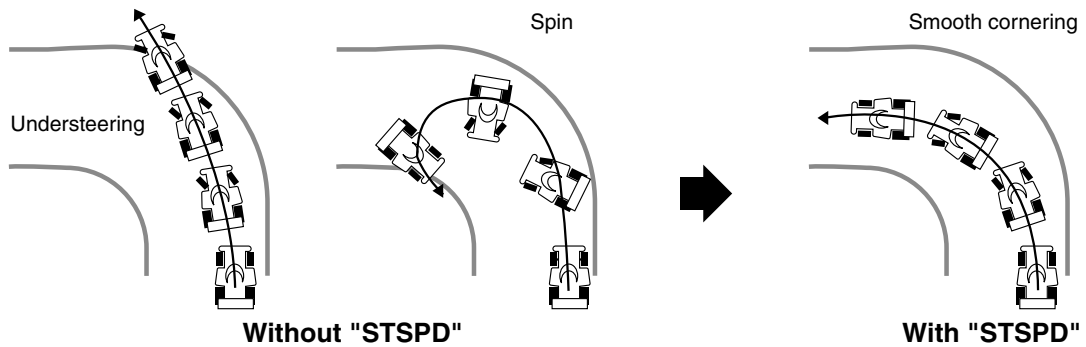

Operation

- This function limits the maximum speed of the steering servo. (Delay function)
- The steering speed when the steering wheel is operated (TURN direction) and returned (RETURN direction) can be independently set.
- If the steering wheel is turned slower than the set speed, the steering servo is not affected.

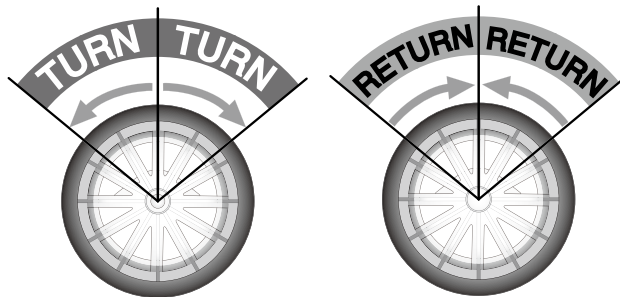

Calling the setup screen

*Calling from menu screen
(Opening Screen)

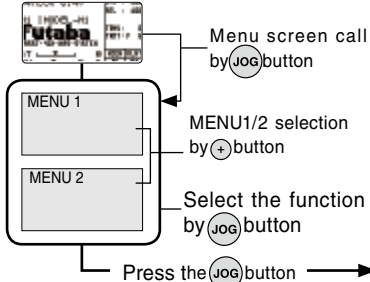

* When the direct call button is set, the setup screen is also called by the following method:

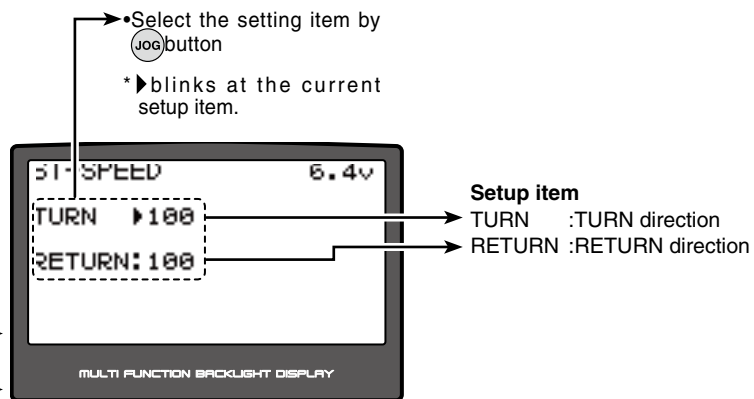
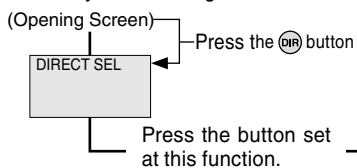

Function

Steering Speed adjustment

(Preparation)

- Select the setting item "TURN" by (JOG) button up or down operation, and make the following adjustments:

1 "TURN" direction adjustment

Use the (+) or (-) buttons to adjust the delay amount.

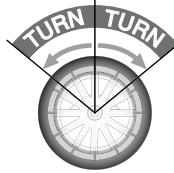

2 "RETURN" direction adjustment

Select the setting item "RETURN" by (JOG) button up or down operation, and use the (+) or (-) buttons to adjust the delay amount.



- ### 3
- When ending setting, return to the initial screen by pressing the (END) button twice (for function menu screen, press the (END) button once).

Setup item selection

- Select by (JOG) button up or down operation.

Adjustment range

1~100% (each direction)
At 100%, there is no delay.

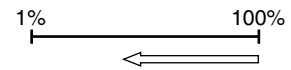

Servo operation is delayed.

Adjust button

- Adjust with the (+) and (-) buttons.
- Return to the initial value "0" by pressing the (+) and (-) buttons simultaneously for about 1 second.

Setting example (Steering servo: S9451 / S9351) . . . (Setting criteria)

- Onroad TURN side: Approx. 50~80% RETURN side: Approx. 60~100%
- Offroad TURN side: Approx. 70~100% RETURN side: Approx. 80~100%

Dial / Trim Setting

The steering speed adjustment "TURN" and "RETURN" can be controlled with digital dial DL1, DL2, DL3 or digital trim DT3 etc. with the function select dial function. (See page 88)

Throttle Speed "THSPD"

(Throttle system)

Sudden throttle trigger operation on a slippery road only causes the wheels to spin and the vehicle cannot accelerate smoothly. Setting the throttle speed function reduces wasteful battery consumption while at the same time permitting smooth, enjoyable operation.



Operation

-Throttle servo (amp) operation is delayed so that the drive wheels will not spin even if the throttle trigger is operated more than necessary. This delay function is not performed when the throttle trigger is returned and at brake operation.

-1 speed, 2 speed, or 3 speed can be selected.

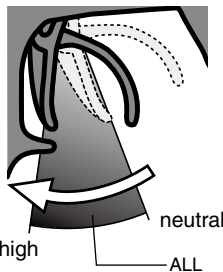

1 SPEED
A delay is set over the entire throttle range.

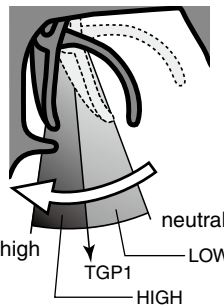

2 SPEED
A delay can be set in 2 ranges with TGP1 as the boundary.

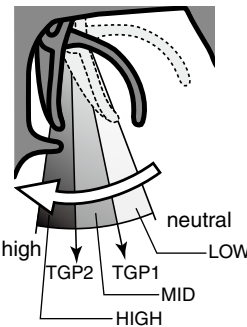

3 SPEED
A delay can be set in 3 ranges with TGP1 and TGP2 as the boundaries.

Calling the setup screen

*Calling from menu screen
(Opening Screen)

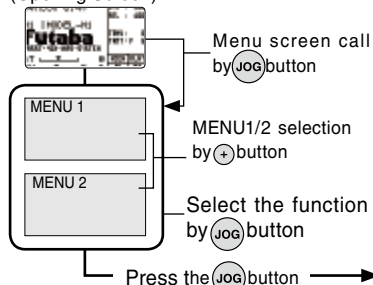

* When the direct call button is set, the setup screen is also called by the following method:

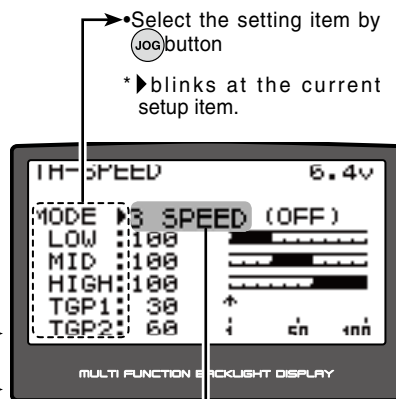
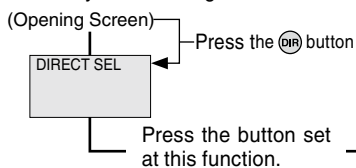

Mode selection

One speed, 2 speed, or 3 speed can be selected at the "MODE" item. The setting item (screen) depends on the mode. The figure at the above is the 3 speed setup screen.

Function

Adjustment method for 1 SPEED

(Preparation)

- Select the setting item "MODE" by (JOG) button up or down operation. Press the (+) or (-) button and select "1 SPEED".

Setting item

MODE :Speed type selection
ALL :Speed adjustment

Setup item selection

- Select by (JOG) button up or down operation.

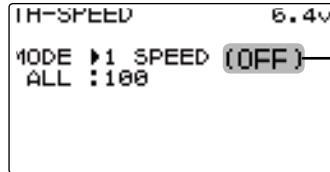

Speed type Select button

- Select with the (+) or (-) buttons.

1 ("ALL" delay adjustment)

Select "ALL" by (JOG) button up or down operation.

Use the (+) or (-) button to adjust the delay of the entire throttle forward side range.

Adjustment range

- 1~100% (each direction)
- At 100%, there is no delay.

Adjust button

- Adjust with the (+) and (-) buttons.
- Return to the initial value "100" by pressing the (+) and (-) buttons simultaneously for about 1 second.

- ## 2
- When ending setting, return to the initial screen by pressing the (END) button twice (for direct selection, press the (END) button once).

Adjustment method for 2 SPEED

(Preparation)

- Select the setting item "MODE" by (JOG) button up or down operation. Press the (+) or (-) button and select "2 SPEED".

Setting item

MODE :Speed type selection
LOW :Low side range speed adjustment
HIGH :High side range speed adjustment
TGP1 :Low and medium speed switching point

Setup item selection

- Select by (JOG) button up or down operation.

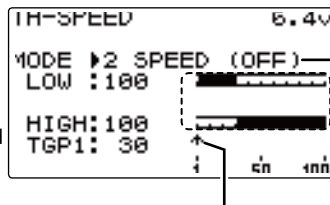

Speed type Select button

- Select with the (+) or (-) buttons.

When a value of 99 or less is set at either LOW or HIGH, the display is switched from OFF to ON by trigger operation.

The LOW and HIGH ranges are linked to the TGP1 set point and displayed.

Throttle trigger position

1 ("LOW" and "HIGH" delay adjustment)

Select "LOW" or "HIGH" by (JOG) button up or down operation.

Use the (+) or (-) button to adjust the delay of the entire throttle forward side range.

Adjustment range

- LOW :1~100
- HIGH :1~100
- At 100%, there is no delay.
- TGP1 :1~100

2 (Speed switching point adjustment)

When you want to change the "LOW" and "HIGH" switching point, select the setting "TGP1" by (JOG) button up or down operation.

Adjust button

- Adjust with the (+) and (-) buttons.
- Return to the initial value by pressing the (+) and (-) buttons simultaneously (approx. 1 sec).
Initial value
LOW, HIGH : "100"
TGP1 :30

- ## 3
- When ending setting, return to the initial screen by pressing the (END) button twice (for function menu screen, press the (END) button once).

Adjustment method for 3 SPEED

(Preparation)

- Select the setting item "MODE" by (JOG) button up or down operation. Press the (+) or (-) button and select "3 SPEED".

Setting item

MODE	:Speed type selection
LOW	:Low side range speed adjustment
MID	:Medium speed range speed adjustment
HIGH	:High side range speed adjustment
TGP1	:Low and medium speed switching point
TGP2	:Medium speed and high switching point

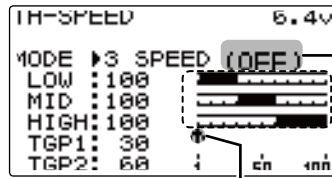

Setup item selection

- Select by (JOG) button up or down operation.

Speed type Select button

- Select with the (+) or (-) buttons.

When a value of 99 or less is set at either LOW or HIGH, the display is switched from OFF to ON by trigger operation.

The LOW and HIGH ranges are linked with the TGP1 set point and displayed.

Throttle trigger position

1 ("LOW", "MID", and "HIGH" delay adjustment)

Select the setting item "LOW", "MID", or "HIGH" by (JOG) button up or down operation.

2 (Speed switching point adjustment)

When you want to change the "LOW", "MID", and "HIGH" switching point, select setting item "TGP1" or "TGP2" by (JOG) button up or down operation.

3 When ending setting, return to the initial screen by pressing the (END) button twice (for function menu screen, press the (END) button once).

Adjustment range

LOW	:1~100
MID	:1~100
HIGH	:1~100
At 100%, there is no delay.	
TGP1	:1~100

Adjust button

- Adjust with the (+) and (-) buttons.
 - Return to the initial value by pressing the (+) and (-) buttons simultaneously (approx. 1 sec).
- Initial value
 LOW, MID, HIGH : "100"
 TGP1 : 30
 TGP2 : 60

Dial / Trim Setting

The steering speed adjustment "LOW", "MID", "HIGH" can be controlled with digital dial DL1, DL2, DL3 or digital trim DT3 etc. with the function select dial function. (See page 88)

Function

Start Function, Engine Cut "START" (Throttle system)

When the throttle trigger is set to full throttle simultaneously with starting when the track is slippery, the car wheels will spin and the car will not accelerate smoothly. When the Start function is activated, merely operating the throttle trigger slowly causes the throttle servo to automatically switch from the set throttle position to a preset point so that the tires do not lose their grip and the car accelerates smoothly.

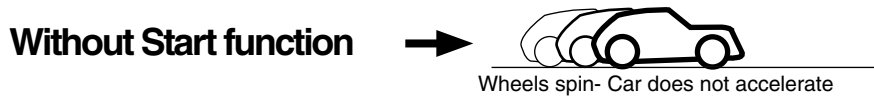
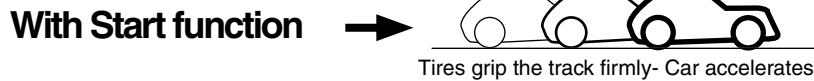

Start Function Operation

- When the throttle trigger is moved to the preset position (trigger position: TG.P), the throttle servo moves to the preset position.
- When the throttle trigger is operated slowly so that the wheels will not spin, the car automatically accelerates to the set speed.
- This function is effective only for the first throttle trigger operation at starting. This function has to be activated before every start.
- When the throttle trigger is returned slightly, the Start function is automatically deactivated and the set returns to normal throttle trigger operation.

Engine Cut Function

When the switch is pressed, the throttle servo will move to the preset position without regard to the throttle trigger position. This is convenient when used to cut the engine of boats, etc. (The function select switch function. See page 86)

Function

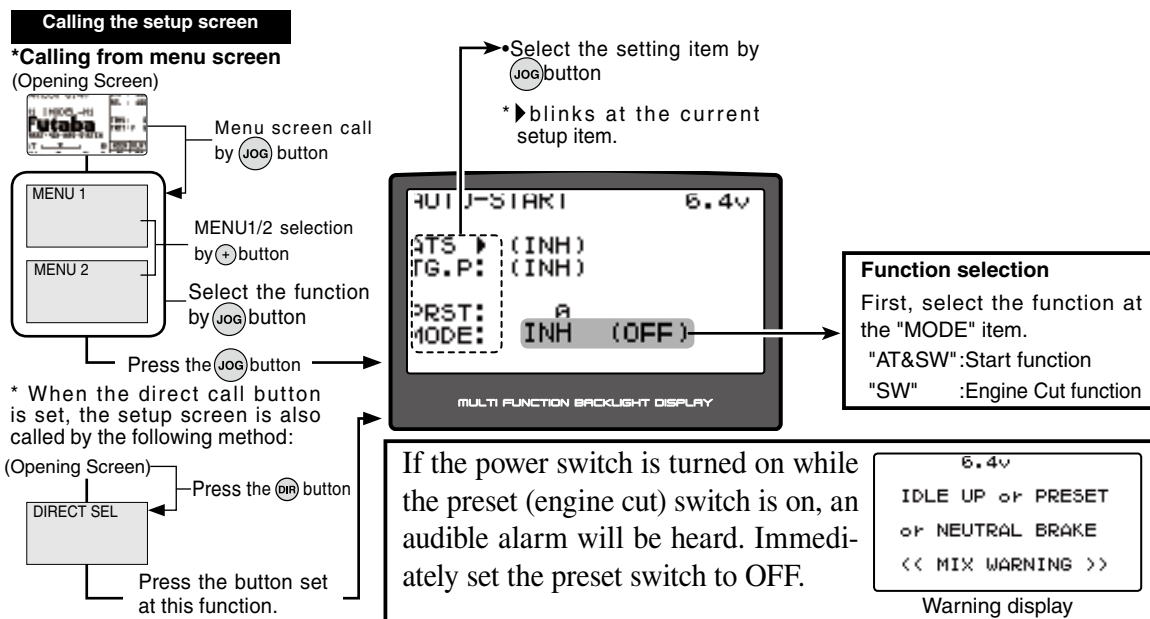

Start function adjustment

(Preparation)

- Select the setting item "MODE" by (JOG) button up or down operation. Press the (+) or (-) button and select "AT&SW".
- Select setup item "TG.P" and make the following adjustments.

Setup items

ATS : READY setting
 TG.P : Throttle position
 PRST : Preset position
 MODE : Function selection

Setup item selection

- Select by (JOG) button up or down operation.

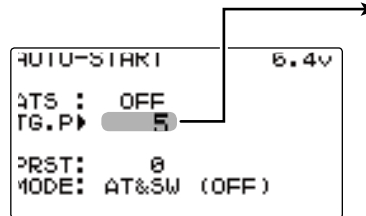

Setup item selection

- Select by (JOG) button up or down operation.

When the trigger is moved to the HI side, and the trigger position is exceeded, "*" is displayed in front of the number.

Adjust button

- Adjust with the (+) and (-) buttons.
- Return to the initial value by pressing the (+) and (-) buttons simultaneously (approx. 1 sec).

1 (Throttle position setup)

Set the throttle position by pressing the (+) or (-) button.

2 (Preset position setup)

Select the setting item "PRST" by (JOG) button up or down operation, and use the (+) and (-) buttons to set the preset position of the throttle servo.

"B100" ~ "B1" : Brake side
 "0" : neutral
 "F1" ~ "F100" : Forward side

Setting Example: (When ESC used with an electric car)

Set the preset position to F75% at EPA100%.

3 ("READY" setting)

Select the setting item "ATS" by (JOG) button up or down operation, and press the (+) and (-) buttons simultaneously for about 1 second. "READY" blinks on the screen and the system enters the READY state. Throttle trigger operation starts the function.

Trigger position (TG.P)

5 ~ 95
 Initial value: 5

Preset position (PRST)

B100 ~ B1, 0, F1 ~ F100
 Initial value: 0

READY setting (ATS)

OFF : off state
 READY: Ready state
 ACT : on state

- ## 4
- When ending setting, return to the initial screen by pressing the (END) button twice (for function menu screen, press the (END) button once).

-If the throttle trigger is moved to the set position while "READY" is flashing, the throttle servo will move to the set position. The throttle operation wait state is reset when the throttle trigger is returned.

-When using the Start function, always set the function by performing step 3 above each time.

Engine Cut function adjustment

(Preparation)

- Use the function select switch to select the switch.

Setup items

PRST : Preset position
MODE : Function selection

Setup item selection

- Select by (JOG) button up or down operation.

```
AUTO-START 0.4V
ATS : (INH)
TG.P: (INH)
PRST▶ 0
MODE: SW (OFF)
```

Setup item selection

- Select by (JOG) button up or down operation.

- Select the setting item "MODE" by (JOG) button up or down operation. Press the (+) or (-) button and select "SW".

1 (Preset position setup)

Select the setting item "PRST" by (JOG) button up or down operation, and use the (+) and (-) buttons to set the preset position of the throttle servo.

"B100" ~ "B1" : Brake side
"0" : neutral
"F1" ~ "F100" : Forward side

Adjust button

- Adjust with the (+) and (-) buttons.
- Return to the initial value by pressing the (+) and (-) buttons simultaneously (approx. 1 sec).

Preset position (PRST)

B100 ~ B1, 0, F1 ~ F100
Initial value: 0

- ## 2
- When ending setting, return to the initial screen by pressing the (END) button twice (for function menu screen, press the (END) button once).

When "TRG-BRK" was set to "CUT OFF" by boat mode function

When "CUT OFF", which prohibits trigger brake side operation, was set in the boat mode (p.78), "TH-BRK" (brake side) of the EPA functions (p.49) cannot be adjusted. The preset position set here becomes the linkage standard. Connect the linkage so that the carburetor is fully closed and the engine is cut off in the preset adjustment range and set the full throttle position by EPA function "TH-FWD". Adjust the idling position by throttle trim.

Servo Throw

The throttle servo operating position (preset position) set by this setting is unrelated to the setting of other functions. Maximum to minimum servo travel can be set. However, the reverse function setting is enabled.

⚠ Caution

- ① Always operate carefully before using this function.

While push switch SW1, SW2, or SW3 with preset function set is in the ON state, the servo (motor controller) is locked in the preset position and does not operate even if the throttle trigger is operated. If the servo was operated at the wrong setting, you may lose control of the car (boat).

A.B.S. Function "A.B.S"

(Throttle system)

When the brakes are applied while cornering with a 4 Wheel Drive or other type of vehicle, understeer may occur. The generation of understeer can be eliminated and corners can be smoothly cleared by using this function.

Operation

- When the brakes are applied, the throttle servo will pulse intermittently. This will have the same effect as pumping the brakes in a full size car.
- The brake return amount, pulse cycle, and brake duty can be adjusted.
- The region over which the ABS is effective can be set according to the steering operation. (Mixing function)

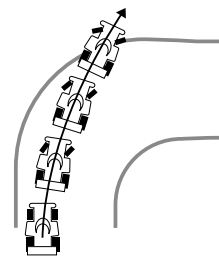

Without A.B.S.

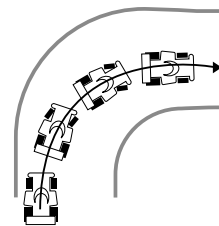

With A.B.S.

Operation display

During ABS operation, the LED blinks (if LED color is not selected as off).

ABS display also appears on the initial screen and menu screen.

When "TRG-BRK" was set to "CUT OFF" by boat mode function

When "CUT OFF", which prohibits trigger brake side operation, was set in the boat mode (p.78), the ABS function will not actually operate even if set.

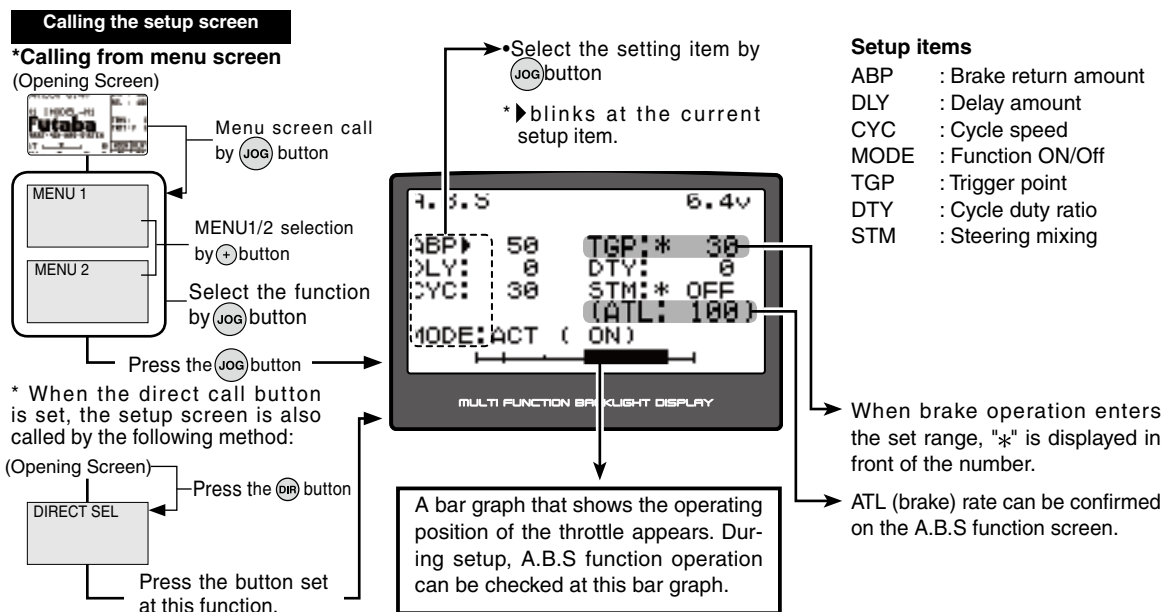

- ABP : Amount of brake return

Sets the rate at which the servo returns versus trigger operation for brake release. When set to 0%, the ABS function is not performed. When set to 50%, the servo returns 50% (1/2) of the trigger operation amount and when set to 100%, the servo returns to the neutral position.

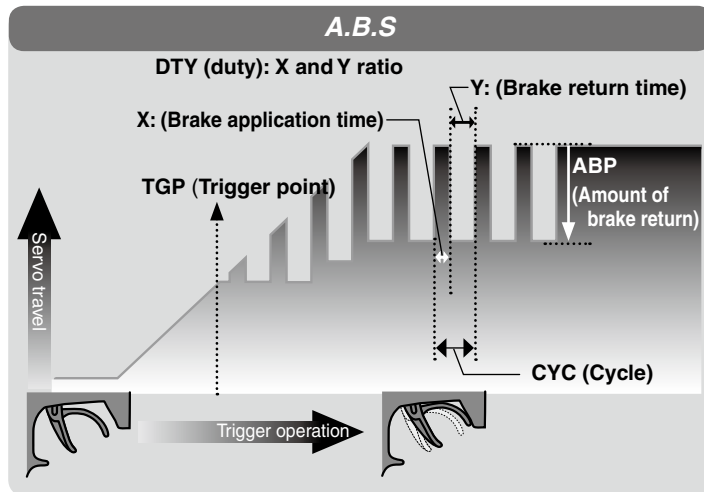

- DLY : Delay

Sets the delay from brake operation to ABS operation. When set to 0%, the ABS function is activated without any delay. At 50%, the ABS function is activated after a delay of approximately 0.7 second and at 100%, the ABS function is activated after a delay of approximately 1.4 seconds.

- CYC : Cycle speed

Sets the pulse speed (cycle). The smaller the set value, the faster the pulse cycle.

- MODE : Function ON/OFF

ABS function ON/OFF setting. When using the ABS function, set to "ACT(ON)".

- TGP : Trigger point

Sets the trigger point at which the ABS function begins to operate at brake operation.

- DTY : Cycle duty ratio

Sets the proportion of the time the brakes are applied and the time the brakes are released by pulse operation. The ratio can be set to +3 ~ 0 ~ -3 in 7 steps.

- STM : Steering mixing

Sets ABS operation ON/OFF according to the steering operation range.

Function

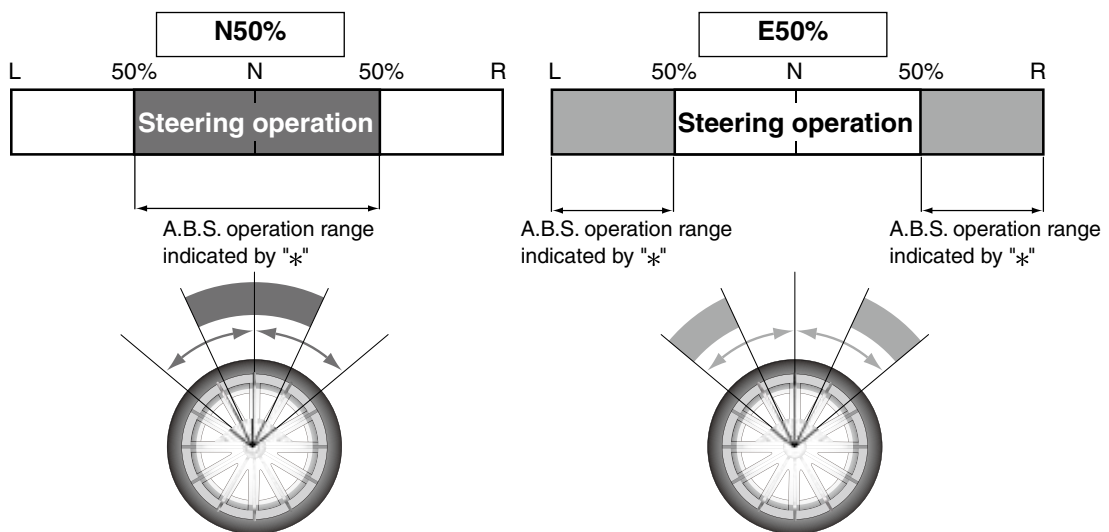

A.B.S function adjustment

1 (Function ON/OFF)

Select the setting item "MODE" by (JOG) button up, down, left or right operation. Set the function to the active state by pressing the (+) or (-) button.

"INH(OFF)" :Function OFF
 "ACT(ON)" :Function ON
 "ACT(OFF)" :Switch OFF when setting switches

2 (Brake return amount adjustment)

Select the setting item "ABP" by (JOG) button up, down, left or right operation. Use the (+) or (-) button to adjust the return amount.

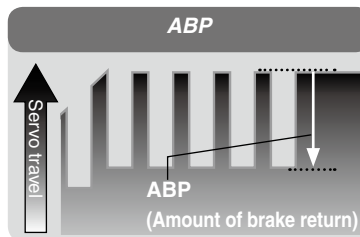

"0" :No return
 "50" :Return to the 50% position of the brake operation amount
 "100" :Return to the neutral position.

3 (Delay amount setup)

Select the setting item "DLY" by (JOG) button up, down, left or right operation. Use the (+) or (-) button to adjust the delay amount.

"0" :A.B.S. function performed without any delay
 "50" :A.B.S. function performed after an approximate 0.7 sec delay.
 "100" :A.B.S. function performed after an approximate 1.7 secs delay.

4 (Cycle speed adjustment)

Select setting item "CYC" by (JOG) button up, down, left or right operation. Use the (+) or (-) button to adjust the pulse speed (cycle).

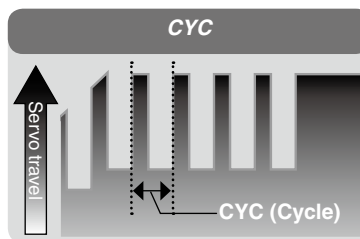

- The smaller the set value, the faster the pulse speed.

5 (Trigger point setup)

Select setting item "TGP" by (JOG) button up, down, left or right operation. Use the (+) or (-) button to adjust the operation point.

- Sets the throttle trigger position at which the A.B.S. function is performed. The number is the % display with the full brake position made 100.

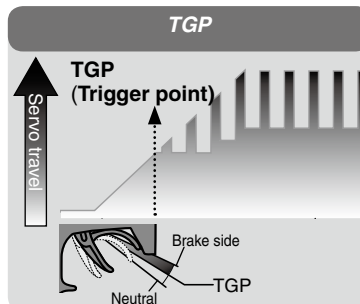

Setup item selection

- Select by (JOG) button up, down, left or right operation.

Adjustment buttons

- Use the (+) and (-) buttons to make adjustments.
 - Return to the initial value by pressing the (+) and (-) buttons simultaneously (approx. 1 sec).

Function ON/OFF (MODE)

INH(OFF), ACT(ON), ACT(OFF)

Brake return amount (ABP)

0 ~ 50 ~ 100
 Initial value; 50

- Brake return amount (ABP) is influenced by the "EXP" rate on the brake side.

Delay amount (DLY)

0 ~ 100
 Initial value; 0

Cycle speed (CYC)

1 ~ 30
 Initial value; 10

Trigger point (TGP)

10 ~ 100
 Initial value; 30



Function

6 (Cycle duty ratio setup)

Select setting item "DTY" by (JOG) button up, down, left or right operation. Use the (+) or (-) button to adjust the duty ratio.

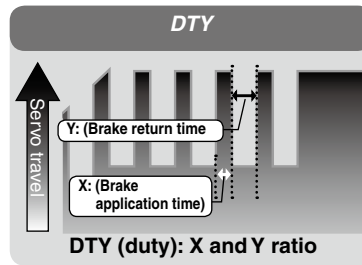

Duty ratio (DTY)

-3 ~ 0 ~ +3
Initial value; 0

"-3" :Brake application time becomes shortest. (Brakes lock with difficulty)

"+3" :Brake application time becomes longest (Brakes lock easily)

(Remark) For low grip, set at the - side and for high grip, set at the + side.

7 (Steering mixing setup)

Select setting item "STM" by (JOG) button up, down, left or right operation. Use the (+) or (-) button to adjust the steering mixing range.

- Sets the range within which the A.B.S. function is performed relative to steering wheel operation.

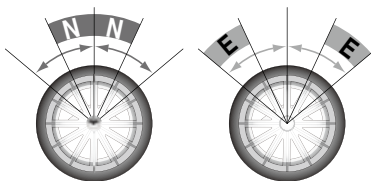

Steering operation

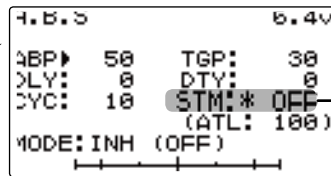

Steering mixing (STM)

OFF, N10 ~ N100, E10 ~ E100
Initial value; OFF

When steering mixing is set and steering operation enters the set range, "*" is displayed in front of the number. When mixing is OFF, the A.B.S function can operate over the entire steering range.

8 When ending setting, return to the initial screen by pressing the (END) button twice (for function menu screen, press the (END) button once).

Dial / Trim Setting

The brake return amount (ABP), delay amount (DLY) and cycle (CYC) can be controlled with digital dial DL1, DL2, DL3 or digital trim DT3 etc. with the function select dial function. (See page 88)

Switch setting

Use PS1, PS2, PS3 to switch the A.B.S. function ON/OFF.
See the function select switch function (See page 86).

Fail Safe Unit

When the T4PK is used with the Futaba fail safe unit (FSU-1), it will operate as described below.

- When the FSU-1 is connected to the throttle channel, and the A.B.S. function has been activated, the FSU-1 LED will flash each time the servo operates. The reason for this is that the FSU-1 responds to sudden data changes caused by A.B.S. function pumping operation. It does not mean that the fail safe function is activated. The servo will not be affected.

Example of A.B.S. function setting when S9451 / S9351 used (There will be a slight difference depending on the state of the linkage.)

- Basic setting

ABP: Approx. 30% (If this value is too high, the braking distance will increase.)

CYC: 5~7

DTY: 0 (When grip is low: - side, when grip is high: + side)

DLY: 10~15%

TH.P: Approx. 70%

STM: OFF

- When the wheels lock, or the car spins, when the brakes are applied fully

ABP: Increase from 30%

DTY: Shift from 0 to - side (-1, -2, -3) →

DLY: Reduce the delay

- When the braking effect is poor and the braking distance is long when the brakes are applied fully

ABP: Decrease from 30%

DTY: Shift from 0 to + side (+1, +2, +3) →

DLY: Increase the delay

1/5 scale car and other independent brakes and ABS

ABS can be independently set for the brakes which are controlled by the 3rd CH and 4th CH by using the brake mixing (BRAKE) function described on page 74. For more information, read the brake mixing (BRAKE) item.

Brake Mixing "BRAKE"

(Throttle, 3rd channel system)

This function is used when the front and rear brakes must be adjusted independently such as a 1/5 scale GP car. This mixing uses the 2nd CH for the rear brakes and the 3rd or 4th CH for the front brakes; or, controls the front brakes with the 3rd CH and 4th CH servos or controls the 2nd CH by independent throttle and controls the rear and front brakes with the 3rd CH and 4th CH. In addition, mixing which varies the 3rd CH and 4th CH brake rate in proportion to steering operation is also possible.

Operation

- When braking, mixing is applied to 2nd CH→3rd CH, 4th CH.
- 3rd CH and 4th CH brake amount, 2nd CH, 3rd CH, and 4th CH brake delay, and 3rd CH and 4th CH brake EXP and ABS can be set.
- Steering mixing which varies front brakes 3rd CH and 4th CH matched to the steering operation can be set. Front brakes 3rd CH and 4th CH can be individually weakened according to the steering left or right operation amount.

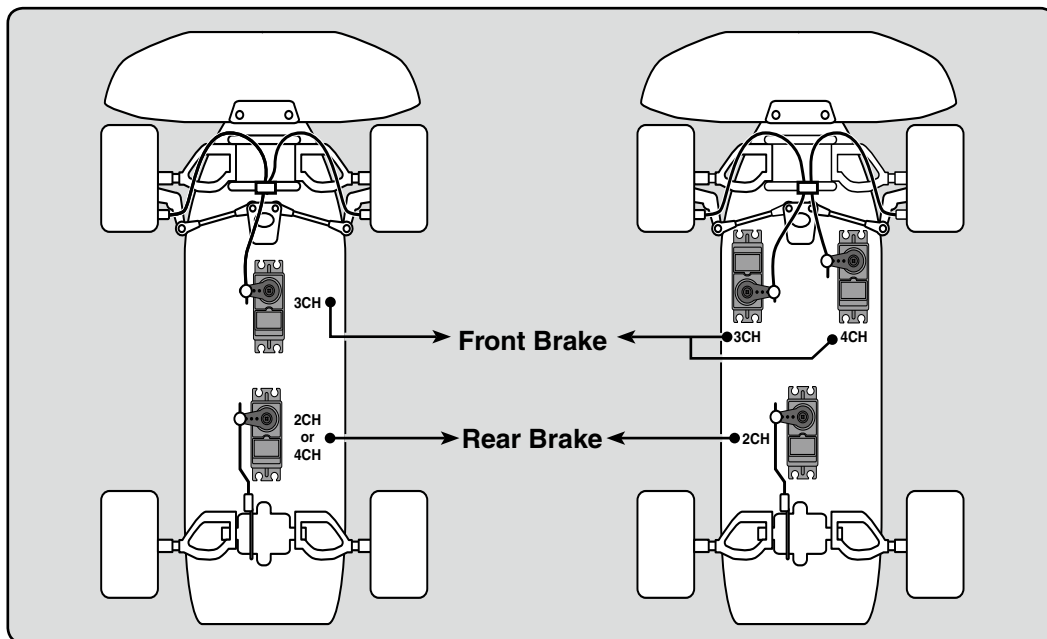

Function

3rd, 4th channels A.B.S.

It is possible to adjust the Brake Return Amount (ABP), Delay Amount (DLY) and Cycle period (CYC) exclusively for the front brake (the 3rd or 4th CH). In doing so, you can use the A.B.S. Function at the front side even if the A.B.S. Function is off for the rear brake (2nd CH). You can use the same procedure as the 2nd CH A.B.S. Function for setting the Cycle Period (CYC), Duty Ratio (DTY) and Steering Mixing (STM). Use SW1, SW2, SW3 to switch the 3rd and 4th channel A.B.S. function ON/OFF.

Calling the setup screen

***Calling from menu screen**

(Opening Screen)

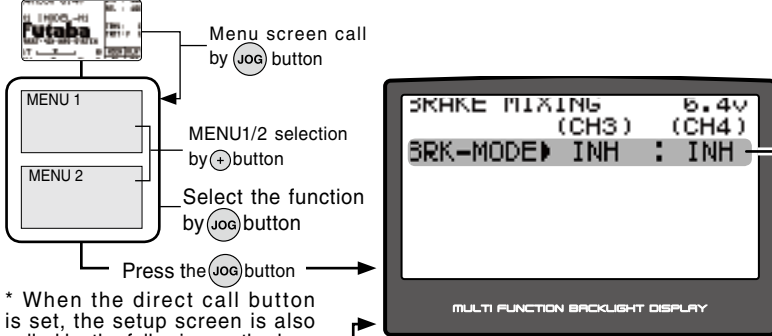

* When set to BRK-MODE "ACT" the brake mixing function is executed and the screen display shown below appears. The screen which is displayed is different when CH3 and CH4 are independently ACT and when both CH3 and CH4 are both ACT.

* When the direct call button is set, the setup screen is also called by the following method:

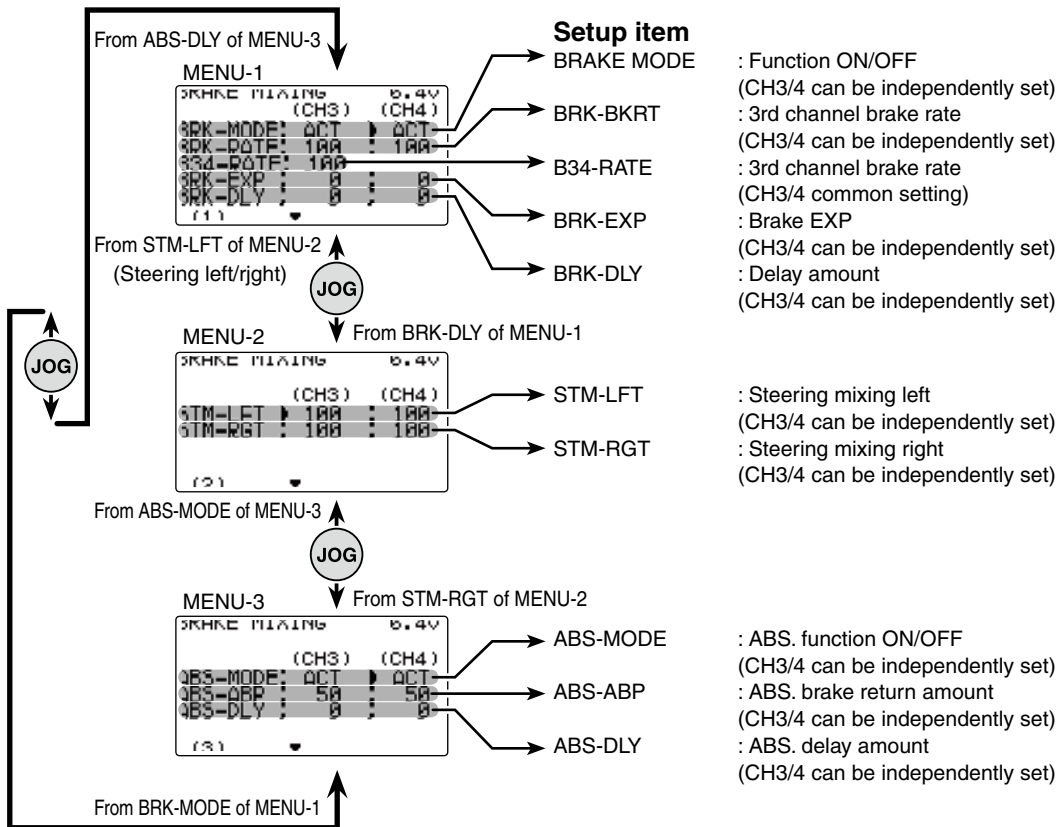
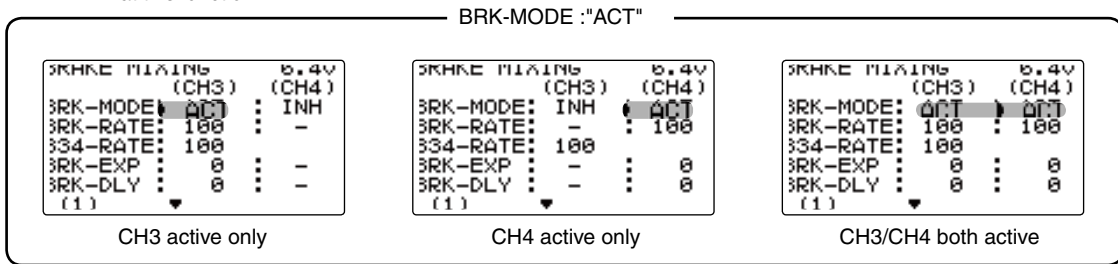
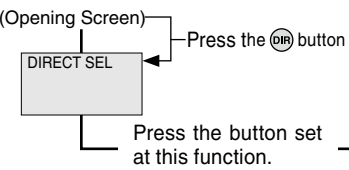

Function

Brake mixing adjustment

1 (Function ON/OFF)

Select the setting items "BRK-MODE(CH3)" or "(CH4)" by (JOG) button up, down, left or right operation. Set the function to the active state by pressing the (+) or (-) button.

"INH(OFF)" :Function OFF
 "ACT(ON)" :Function ON

Setup item selection

- Select by (JOG) button up, down, left or right operation.

Adjustment buttons

- Use the (+) and (-) buttons to make adjustments.
 - Return to the initial value by pressing the (+) and (-) buttons simultaneously (approx. 1 sec).

Function ON/OFF (MDE)

INH(OFF), ACT(ON), ACT(OFF)

2 (3rd channel brake rate)

Select setup items "BRK-RATE(CH3)" or "(CH4)" by (JOG) button up, down, left or right operation, and use the (+) and (-) buttons to adjust the Brake rate amount.

```

BRKKE MIXING          6.4V
      (CH3)  (CH4)
BRK-MODE: ACT  ACT
BRK-RATE: 100 100
B34-RATE: 100
BRK-EXP  : 0   0
BRK-DLY  : 0   0
(1)
    
```

Brake rate (RATE)

0 ~ 100
 Initial value:100

- When adjusting the brake amount of both brakes after individually adjusting the CH3 and CH4 brakes, select "B34-RATE".

Brake EXP rate (EXP)

-100 ~ 0 ~ +100%
 Initial value:0

3 (3rd & 4th channel brake-EXP)

With the jog dial, move the blinking cursor up/down, left or right to select "BRK-EXP (CH3) or (CH4)". Use the plus (+) button to adjust for a faster brake response or use the minus (-) button for a slower or milder brake response.

-When using CH3 and CH4 servos as front brakes and using EXP, set the (CH3) EXP amount and (CH4) EXP amount separately.

Delay amount (DLY)

(CH3)F100~F1, 0 ,R1~R100
 (CH4)100 ~ 0
 Initial value:0

4 (Delay amount setup)

Select setup items "BRK-DLY(CH3)" or "(CH4)" by (JOG) button up, down, left or right operation, and use the (+) and (-) buttons to adjust the delay amount.

"0" : No delay
 (CH3)"F100" : CH3 (front) maximum delay amount
 (CH3)"R100" : CH2 (rear) maximum delay amount
 (CH4)"100" : CH4 maximum delay amount

```

BRKKE MIXING          6.3V
      (CH3)  (CH4)
BRK-MODE: ACT  ACT
BRK-RATE: 100 100
B34-RATE: 100
BRK-EXP  : 0   0
BRK-DLY  F 5   5
(1)
    
```

- When using the CH3 and CH4 servos for the front brakes and applying a delay to the front brakes set the (CH3)F delay amount and (CH4) delay amount separately.

```

BRKKE MIXING          6.3V
      (CH3)  (CH4)
BRK-MODE: ACT  ACT
BRK-RATE: 100 100
B34-RATE: 100
BRK-EXP  : 0   0
BRK-DLY  R 0   0
(1)
    
```

- When the CH2 servo is used for the rear brakes and the CH3 servo is used for the front brakes, delay is applied to either the F (front) or R (rear) side.

5 (Steering mixing)

Use this function when you want to weaken the front brakes when steering was operated.

Select the setting item "STM-LFT" or "STM-RGT" by (JOG) button up, down, left, or right operation. Use the (+) or (-) button to adjust the brake amount.

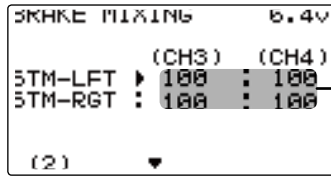

Brake rate (STM-LFT/STM-RGT)
0 ~ 100
Initial value:100

Use "STM-RGT" (CH3)(CH4) to adjust the brake amount relative to the steering right operation amount. The smaller the value, the weaker the front brakes. Set value "100" is the state in which steering mixing is not performed.

- The mixing amount can be adjusted from 0 to 100 range.

6 (3rd & 4th channels brake-A.B.S ON/OFF)

Select setup item "ABS-MODE(CH3)" or "(CH4)" by (JOG) button up, down, left or right operation. Set the function to the "ACT" state by pressing the (+) or (-) button.

Function ON/OFF (ABS-MODE)
INH(OFF), ACT(ON), ACT(OFF)

7 (3rd & 4th channels brake-A.B.S return amount adjustment)

Select setup item "ABS-ABP(CH3)" or "(CH4)" by (JOG) button up, down, left or right operation, and use the (+) and (-) buttons to adjust the return amount.

Brake return amount (ABS-ABP)
0 ~ 50 ~ 100
Initial value; 50
"0" :No return
"50" :Return to the 50% position of the brake operation amount
"100" :Return to the neutral position.

8 (3rd & 4th channels brake-A.B.S delay amount setup)

Select setup item "ABS-DLY(CH3)" or "(CH4)" by (JOG) button up, down, left or right operation, and use the (+) and (-) buttons to adjust the delay amount.

Delay amount (ABS-DLY)
0 ~ 100
Initial value; 0
"0" :A.B.S. function performed without any delay
"50" :A.B.S function performed after an approximate 0.7 sec delay.
"100" :A.B.S. function performed after an approximate 1.7 secs delay.

9 When ending setting, return to the initial screen by pressing the (END) button twice (for function menu screen, press the (END) button once).

Dial / Trim Setting

The function select dial function can control the 3rd/4th channels brake rate (RATE), delay amount (DLY), and 3rd channel brake-A.B.S return amount (ABP) ...etc setting using button trim DL1, DL2, DL3 or digital trim DT3 etc. (See page 88)

When BIGCAR is selected on the "MENU-T" function (See page 38, 103), 3rd channel brake rate (RATE) adjustment is automatically assigned to dial DL3.

Shutting off brake side operation

When brake side operation is unnecessary with a boat, etc., it can be shut off.

Tilt mixing

Tilt mixing uses an outboard engine and applies bidirectional mixing from rudder (steering) to channel 3 and from channel 3 to rudder so that with a boat rudder operation and tilt mixing operation can be performed by 2 servos.

Tilt mixing can be performed by rudder operation by steering wheel and 3rd channel.

Effect of set value of other functions on tilt mixing

Steering side EPA function, STEXP function, STSPD function, or D/R function setting also affects channel 3 side operation. However, the channel 3 servo is not reversed by setting the steering side reverse function.

Calling the setup screen

*Calling from menu screen (Opening Screen)

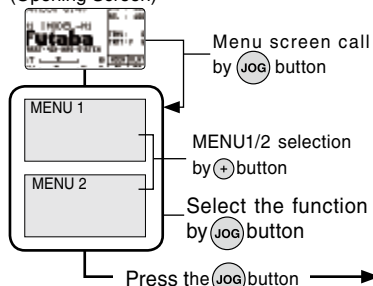

* When the direct call button is set, the setup screen is also called by the following method:

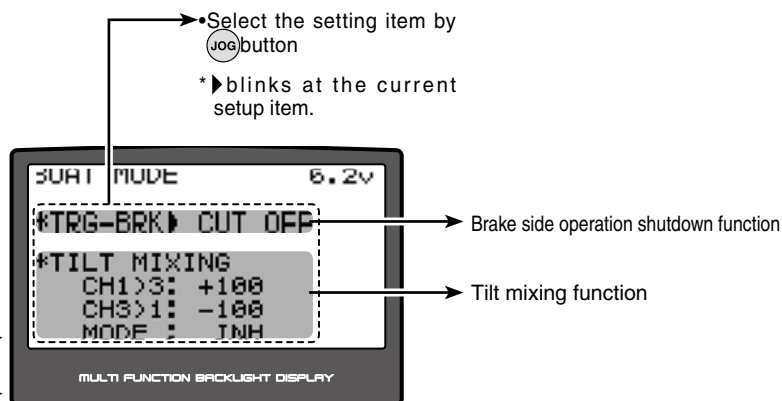
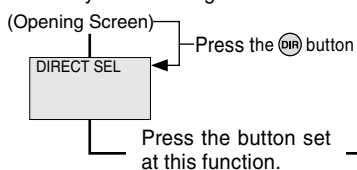

Function

Prohibiting brake side operation

1 (Shutting down brake side operation)

Select the setting item "TRG-BRK" by (JOG) button up or down operation. Use the (+) or (-) button to select "CUT OFF".

- "NORMAL" :Normal trigger operation
- "CUT OFF" :Trigger brake side operation shut down

2 When ending setting, return to the initial screen by pressing the (END) button twice (for function menu screen, press the (END) button once).

Setup item selection

- Select by (JOG) button up or down operation.

Adjustment buttons

- Use the (+) and (-) buttons to make adjustments.

Brake side operation (TRG-BRK)

NORMAL, CUT OFF

Tilt mixing adjustment

(Preparation)

- Use the function select dial function to select the 3rd channel operation dial. (page 88)

1 (Function ON/OFF)

Select the setting item "MODE" by (JOG) button up or down operation. Set the function to the "ON" state by pressing the (+) or (-) button.

"INH" :Function OFF
"ON" :Function ON

2 (CH1>CH3 mixing amount adjustment)

Select setup item "CH1>3" by (JOG) button up or down operation, and use the (+) and (-) buttons to adjust the mixing amount.

"+" :Operate in same direction as steering
"-" :Operate in opposite direction of steering

3 (CH1>CH1 mixing amount adjustment)

Select setup item "CH3>1" by (JOG) button up or down operation, and use the (+) and (-) buttons to adjust the mixing amount.

"+" :Operate in same direction as channel 3
"-" :Operate in opposite direction of channel 3

- ### 4
- When ending setting, return to the initial screen by pressing the (END) button twice (for function menu screen, press the (END) button once).

Slave channel output (Initial value)

Steering > 3rd channel side	: +100%
3rd channel > Steering side	: -100%

Dial / Trim Setting

The mixing rate amount can be controlled with digital dial DL1, DL2, DL3 or digital trim DT3, etc. with the function select dial function. (Page 88)
--

Adjustment buttons

- Use the (+) and (-) buttons to make adjustments.
- Return to the initial value by pressing the (+) and (-) buttons simultaneously (approx. 1 sec).

Function ON/OFF (MODE)

INH(OFF), ACT(ON), ACT(OFF)

Mixing amount (CH1>3)

-100~+100
Initial value: +100

Mixing amount (CH3>1)

-100~+100
Initial value: -100

Throttle Mode "THMOD"

(Throttle system)

-The neutral brake function is a function switch function (page 86), and setting the neutral brake function ON/OFF switch is necessary.

Neutral brake, which applies the brakes at the throttle trigger neutral position, can be set. However, for Futaba speed controller (ESC) MC850C, MC601C, MC401CR, etc, considering safety, when the neutral position is not confirmed, the set will not enter the operation mode to prevent the motor from rotating instantly when the power was turned on. When using the MC850C, MC601C, MC401CR, etc., check that the ESC is in the neutral position and set the neutral brake function switch to ON after the set enters the operation mode.

Operation display

An LED blinks while the neutral brake function is active (when LED is enabled). In addition, **N·B** appears on the initial screen and menu screen.

-This function allows selection of the forward side and brake (reverse) side operation ratio from 70:30 or 50:50 by changing the neutral position of the throttle servo.

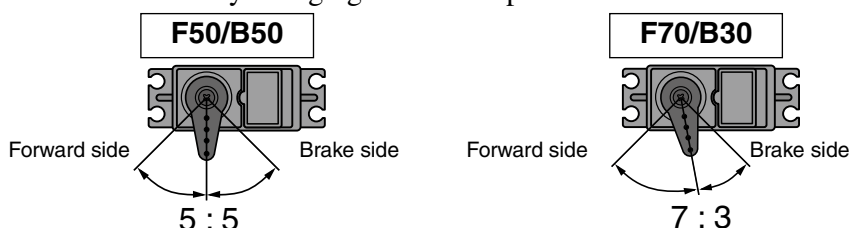

When "TRG-BRK" was set to "CUT OFF" by boat mode function

When "CUT OFF", which provides trigger brake side operation in the boat mode (page 78), was set, the neutral brake function cannot be used because brake operation is stopped. In addition, the neutral position does not change even though the throttle mode is changed.

Function

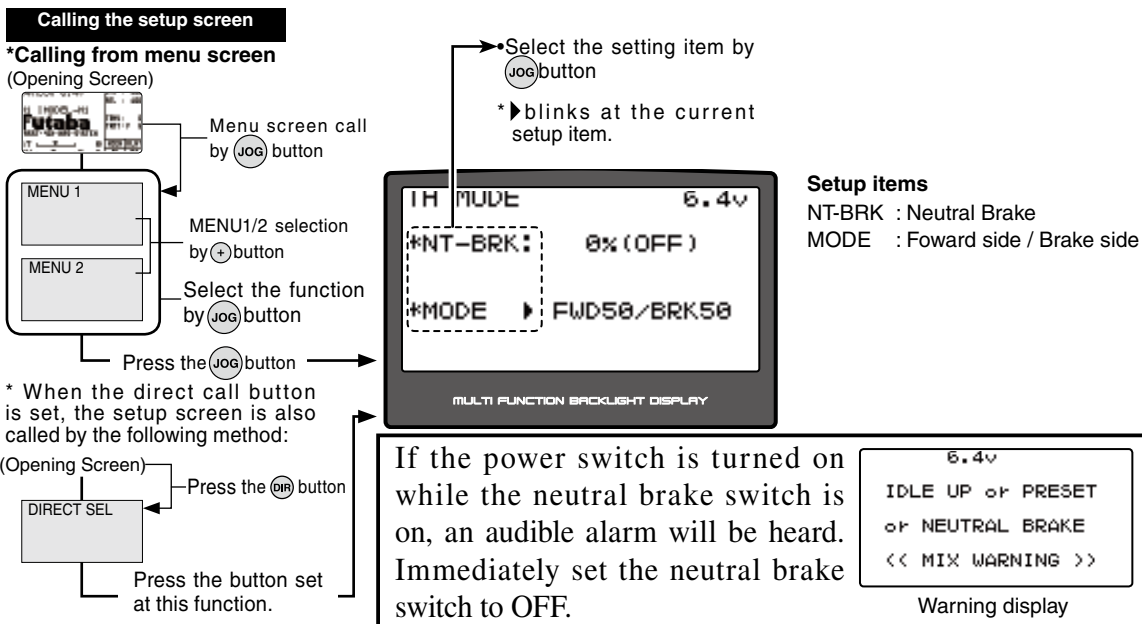

Neutral Brake function adjustment

(Preparation)

- Use the function select switch function to select the switch. (page 86)

1 (Neutral brake rate)

Select the setting item "NT-BRK" by (JOG) button up or down operation. Use the (+) and (-) buttons to set the neutral brake rate.

- ### 2
- When ending setting, return to the initial screen by pressing the (END) button twice (for function menu screen, press the (END) button once).

Reference

The ESC neutral brake function and T4PK neutral brake function can be used simultaneously. However, when setting is difficult to understand, we recommend that only one neutral brake function be used.

Dial / Trim Setting

When the neutral brake function is "ON", the neutral brake rate (RATE) adjustment is automatically assigned to the throttle trim (DT1/2/3 or DL1/2/3).

Affect of set value of other functions on neutral brake

Throttle side EPA function, or ATL function setting also affects neutral brake side operation.

Selecting the throttle mode

1 (Throttle mode selection)

Select the setting item "MODE" by (JOG) button up or down operation. Select "F50/B50" or "F70/B30" by (+) or (-) button.

"F50/B50" =Forward 50% : Back50%
"F70/B30" =Forward 70% : Back30%

- ### 2
- When ending setting, return to the initial screen by pressing the (END) button twice (for function menu screen press the (END) button once).

Adjustment buttons

- Use the (+) and (-) buttons to make adjustments.

Throttle mode (MODE)

F50/B50, F70/B30

This function is a function select switch function. The idle-up function ON/OFF switch must be set. (Page 86)

It is used to improve engine starting performance by raising the idling speed when the engine of a gasoline car (boat) is started.

This function is also effective when you want to prevent braking when the power was turned off during running due to the effect of gear ratio setting and the motor used with a motor car. However, when using the MC850C, MC601C, MC401CR, etc., check the ESC neutral position and set the idling function switch to ON after the set enters the operation mode, the same as the neutral brake function (page 80).

Operation

The throttle neutral position is offset to the forward side or brake side. There is no linkage locking, etc. because there is no change near the maximum operation angle even when the neutral position is offset by this function.

Calling the setup screen

*Calling from menu screen
(Opening Screen)

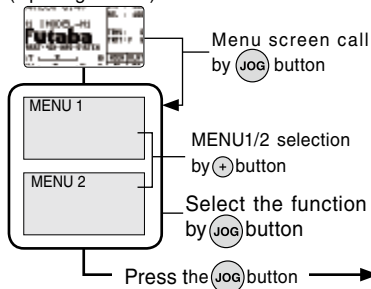

* When the direct call button is set, the setup screen is also called by the following method:

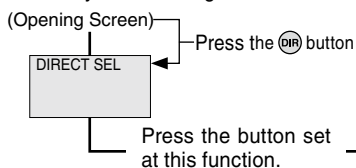

Operation Display

While this function is ON, the LED blinks. (When LED is active) **IDL** also appears on the initial screen and menu screen.

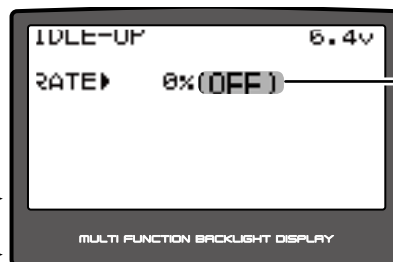

Idle-Up on/off state.

The LED blinks while the Idle-Up function is on.

If the power switch is turned on while the idle-up switch is on, an audible alarm will be heard. Immediately set the Idle-Up switch to OFF.

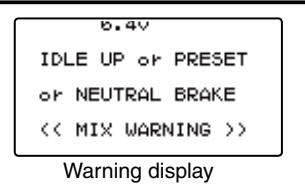

Warning display

Function

Idle-Up function adjustment

(Preparation)

- Use the function select switch function to select the switch. (page 86)

1 (Idle-Up rate)

Use the (+) and (-) buttons to set the Idle-Up rate.

2 When ending setting, return to the initial screen by pressing the (END) button twice (for function menu screen, press the (END) button once).

Adjust button

- Adjust with the (+) and (-) buttons.
- Return to the initial value "0" by pressing the (+) and (-) buttons simultaneously for about 1 second.

Idle-Up rate (RATE)

D50% ~ D1%, 0%, U1% ~ U50%

Initial value: 0%

"D": Brake side

"U": Forward side

Programmable Mixes 1, 2 "PMIX1, 2"

(All channels)

These functions allow you to apply mixing between the steering, throttle, channel 3 and channel 4.

Two programmable mixing systems can be used. The programmable mixing 1 and programmable mixing 2 set-up screens are independent.

Additional Functions

- When the steering or throttle channel is the master channel (channel that applies mixing), trim data can be added. (Trim mode)
- The mixing mode selection. (Master mixing mode)
- The master channel mixing center point (point at which the direction changes) can be offset. (Offset function)

Movement of the slave channel side

The movement of the master channel side will be added to the movement of the slave channel side.

When "TRG-BRK" was set to "CUT OFF" by boat mode function

When "CUT OFF", which prohibits trigger brake side operation, was set in the boat mode (p.78), since brake side operation is shut off, when the master channel (MST) is set to throttle, only "FWRD" side mixing is activated. "BRAK" side mixing is not activated.

Calling the setup screen

*Calling from menu screen
(Opening Screen)

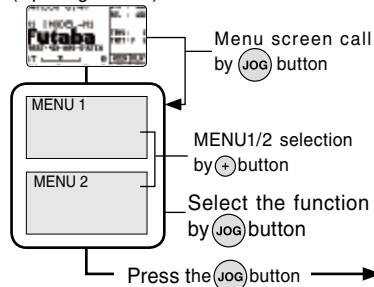

* When the direct call button is set, the setup screen is also called by the following method:

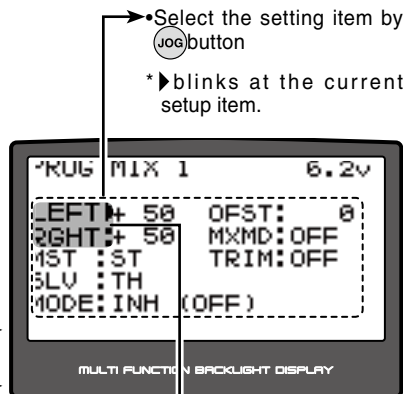
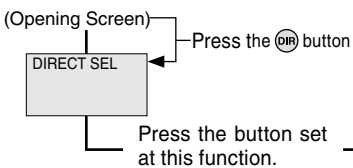

These setup items are different depending on the master channel.
Upper side : LEFT/FWRD/UP
Lower side : RGHT/BRAK/DOWN

Setup items

- LEFT :Mixing rate (Left side)
- RGHT :Mixing rate (Right side)
- MST :Master channel
- SLV :Slave channel
- MODE :Function ON/OFF
- OFST :Offset
- MXMD :Mix mode
- TRIM :Trim mode

Adjust button

- Adjust with the (+) and (-) buttons.
- Return to the initial value "100" by pressing the (+) and (-) buttons simultaneously for about 1 second.

Function

Program mixing adjustment

(Preparation)

- Use the function select switch function (page 86) to select the switch. (as desired)

1 (Mixing function ON/OFF)

Select the setting item "MODE" by (JOG) button up, down, left, or right operation. Press the (+) or (-) button and set the function to the "ACT" state.

"INH" :Function OFF
"ACT" :Function ON

2 (Master channel)

Select setup item "MST" by (JOG) button up, down, left, or right operation, and select the master channel by pressing the (+) or (-) button.

3 (Slave channel)

Select setup item "SLV" by (JOG) button up, down, left, or right operation, and select the slave channel by pressing the (+) or (-) button.

4 (Left, forward or up side mixing amount adjustment)

Select the setting item "LEFT", "FWRD", or "UP" by (JOG) button up, down, left, or right operation. Use the (+) or (-) button and adjust the right, brake, or down side mixing amount.

5 (Right, brake or down side mixing amount adjustment)

Select the setting item "RGHT", "BRAK", or "DOWN" by (JOG) button up, down, left, or right operation. Use the (+) or (-) button and adjust the right, brake, or down side mixing amount.

6 (Offset amount setup)

Select setup item "OFS" by (JOG) button up, down, left, or right operation, and use the (+) and (-) button to adjust the offset amount.

7 (Mixing mode setup)

Select setup item "MXD" by (JOG) button up, down, left, or right operation, and use the (+) or (-) button to select the mixing mode.

"OFF" :Mixing proportional to master channel operation.
"MIX" :Mixing by master channel another function considered.

Setup item selection

- Select by (JOG) button up, down, left or right operation.

Switch

PRG MIX1 : Program mixing 1
PRG MIX2 : Program mixing 2

Function ON/OFF (MODE)

INH, ACT

Channel selection (MST)

ST, TH, CH3, CH4
Initial value :PMIX1(ST)
PMIX2(TH)

Channel selection (SLV)

ST, TH, CH3, CH4
Initial value :PMIX1(TH)
PMIX2(CH3)

Mixing amount

-100~0~+100
Initial value: +50

Mixing amount

-100~0~+100
Initial value: +50

Offset amount (OFS)

-100~0~+100
Initial value: 0

Mixing mode (MXD)

OFF, MIX
Initial value: OFF

8 (Trim mode setup)

Select setup item "TRM" by (JOG) button up, down, left, or right operation, and use the (+) or (-) button to select the mixing mode.

- "OFF" : Trim is added.
- "ON" : Trim is removed.

Trim mode (TRM)
OFF, ON
Initial value: OFF

9 When ending setting, return to the initial screen by pressing the (END) button twice (for function menu screen, press the (END) button once).

When Steering and Throttle Travel is Insufficient

When the steering servo travel is insufficient even when D/R is 100% and EPA is 120%, programmable mixing can be used to increase the travel somewhat.

(Reference data)

- PROG NIX1->ON
- MST (master channel) -> ST Mixing is applied from steering
- SLV (slave channel) ->ST Mixing is applied to steering and the travel is increased.
- RGHT -> 10% [When subtrim is centered (0%)]
- LEFT -> 10% [When subtrim is centered (0%)]
- OFST -> 0%
- MXMD -> MIX
- TRIM -> OFF

However, the operating range of the servo is exceeded even if a large value is input at RIGHT and LEFT and a zone over which the servo does not operate even when the stick is moved to the left or right is created. A zone over which the servo does not operate is also generated at the moving side when the subtrim is moved to the left and right. Therefore, set the RIGHT and LEFT value by checking servo operation.

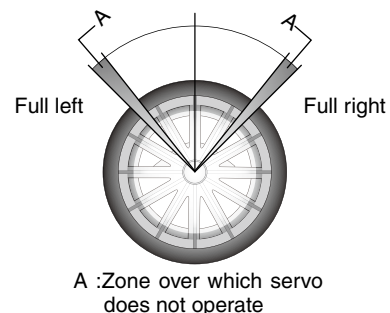

When the throttle servo travel is insufficient at ATL 100% and EPA120%, the same action can be performed by making TH (throttle) both the MST and SLV when steering.

When both steering and throttle operations are performed, use both PROG MIX1 and PROG MIX2 program mixing.

Switch Setting

Select the program mixing 1,2 function ON/OFF switch with the function select switch function. (See page 86)

Dial / Trim Setting

The mixing amount can be adjusted by using the function dial function (p.88).

Function Select Switch "SWTCH"

This function allows selection of the function to be performed by the switches (PS1/PS2/PS3) and setting of the direction, etc. of operation.

- The table to the right shows the functions that can be assigned to each push switch.
- PS1 and PS2 can be made alternate operation (ON/OFF switched each time SW pressed). (NOR/ALT)
- The direction of operation of PS3 can be reversed. (NOR/REV)

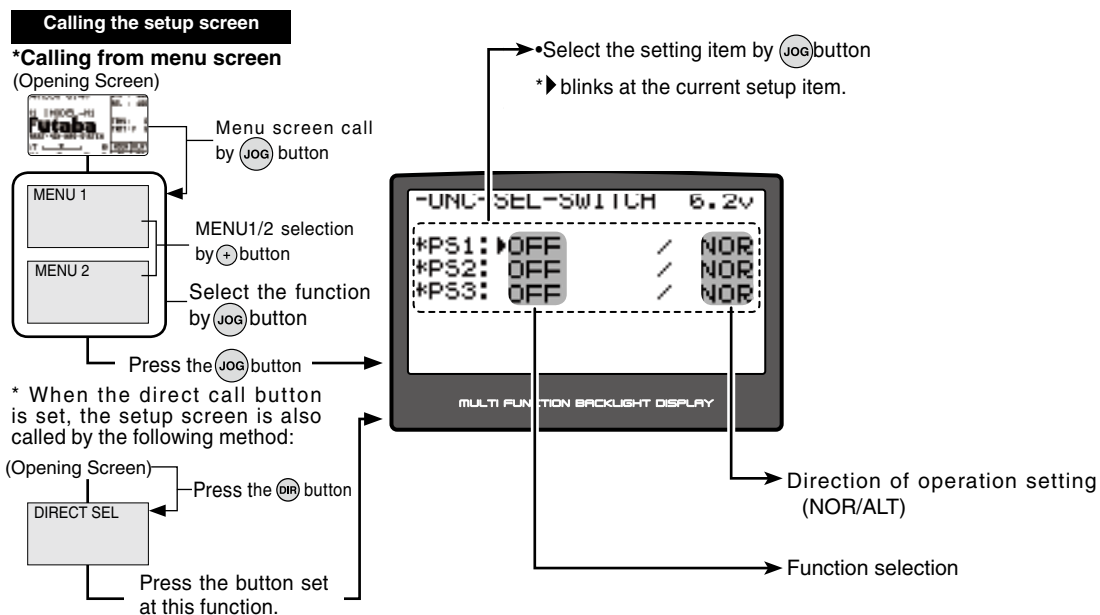

Function select switch setup

1 (Setting SW selection)

Select the item you want to set by (JOG) button up, down, left, or right operation.

2 (To select or change a function for SW)

Select one of the functions for "SW" by pressing (+) or (-) button.

(To change the operation mode)

Select the operation mode for "SW" by pressing (+) or (-) button.

3 When ending setting, return to the initial screen by pressing the (END) button twice (for function menu screen, press the (END) button once).

Setup item selection

- Select by (JOG) button up, down, left or right operation.

Setup buttons

- Use the (+) and (-) buttons to make adjustments.
- Press the (+) and (-) buttons simultaneously (approx. 1 sec) to return to the initial screen.

Initial value:

PS1,PS2,PS3 : "OFF", "NOR"

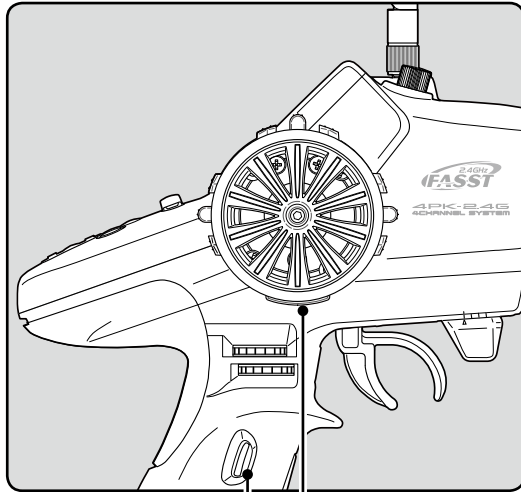

PS1
PS2

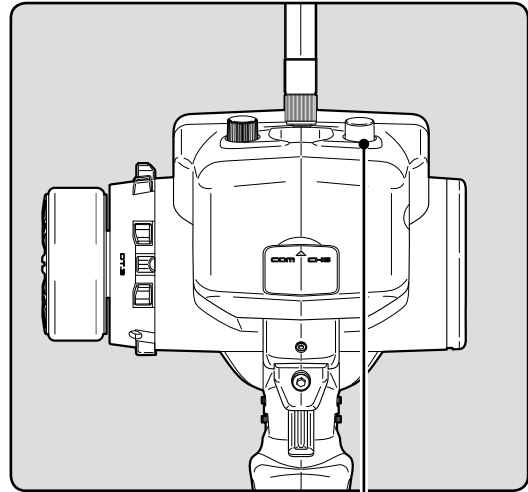

PS3

Settable functions (SW1/SW2/SW3)	
Abbreviation used on setup screen	Function name, etc
PRESET	Start function /Preset (Engine cut)
NT-BRAKE	Neutral brake function ON/OFF
A.B.S.CH2	A.B.S function (2CH)ON/OFF
A.B.S.CH3,CH4	A.B.S function (3CH,4CH)ON/OFF
2ND COND	2nd condition function ON/OFF
IDLE-UP	Idle up function ON/OFF
PROG MIX1	Program mixing1 function ON/OFF
PROG MIX2	Program mixing2 functionON/OFF
CH3	channel 3
CH4	channel 4
LAP STAR	Timer function start (SW3 not possible)
LAP RESET	Timer function reset (SW3 not possible)
OFF	Not used



Function

Function Select Dial "DIAL"

This function allows selection of the function performed by the digital dial (DL1/DL2/DL3) and digital trimmers (DT1/DT2/DT3), step amount adjustment, and operating direction reversal.

- The table below lists the functions that can be assigned to each dial and digital trimmer. The assigned function is also displayed on the opening screen together with the current adjustment value. They are displayed in DL1, DL2, DL3, DT1, DT2, and DT3 order, from top to bottom.
- The step amount can be adjusted. The table below shows the relationship between set value and step amount.
- The operation direction can be reversed. (NOR/REV)

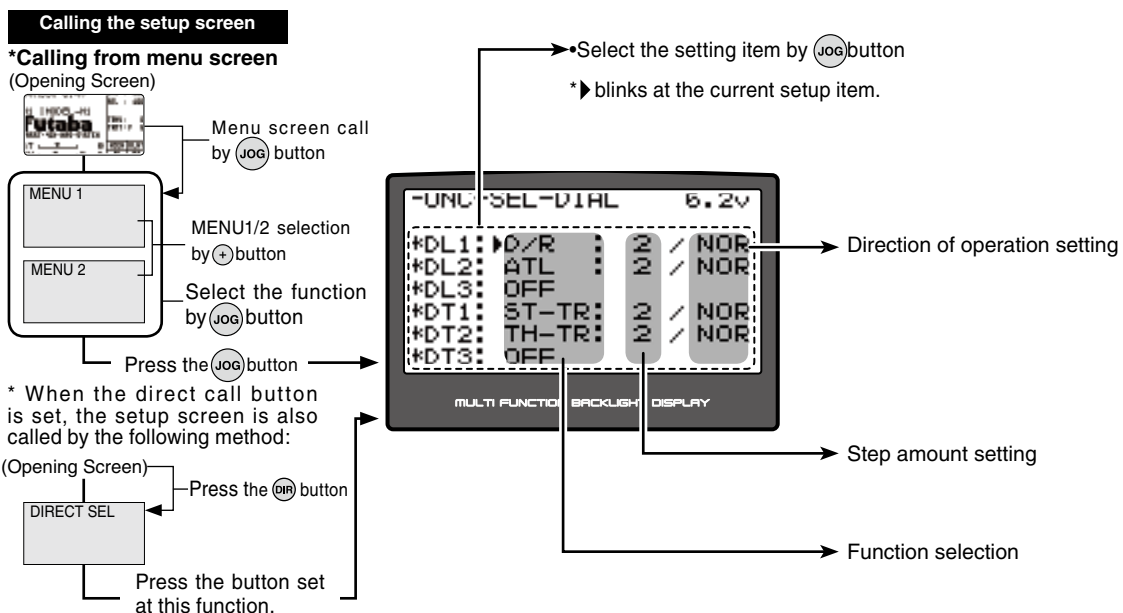

Function select dial setup

1 (Setting Dial selection)

Select the item you want to set by (JOG) button up, down, left, or right operation.

2 (To select or change a function for Dial)

Select one of the functions for "DIAL" by pressing (+) or (-) button.

(To change the step amount)

Use the (+) or (-) button to set the step amount.

(When changing the direction of operation)

Use the (+) or (-) button to dial the direction.

3 When ending setting, return to the initial screen by pressing the (END) button twice (for function menu screen, press the (END) button once).

Setup item selection

- Select by (JOG) button up, down, left or right operation.

Adjustment buttons

- Use the (+) and (-) buttons to make adjustments.
- Press the (+) and (-) buttons simultaneously (approx. 1 sec) to return to the initial screen.

Initial value:

DL1 : "D/R", "2", "NOR"

DL2 : "ATL", "2", "NOR"

DL3 : "OFF"

DT1 : "ST-TR", "2", "NOR"

DT2 : "TH-TR", "2", "NOR"

DT3 : "OFF"

Relationship between set value and step amount

(Setting range: 1, 2, 5, 10, 20, 30, 40, 50, 100, 2PS)

-Steering trim/throttle trim

When set to the minimum "1", the total trim operating width is 200 clicks. For "100", the total operating width is 2 clicks and for 2PS, the total operating width is 1 click.

-Rate, etc. setting

This is the % value which is operated by 1 click relative to the set value of each rate. Since the total operating width of functions having a rate of -100~0~+100 is 200%, when set to "100", the total operating width is 2 clicks. Since the total operating width of functions with a 0~100 rate is 100%, "100" and 2PS are operated by 1 click.

-Channel 3/4

When set to the minimum "1", the total operating width of channel 3 is 200 clicks. For "100", the total operating width is 2 clicks and 2PS is operated by 1 click.

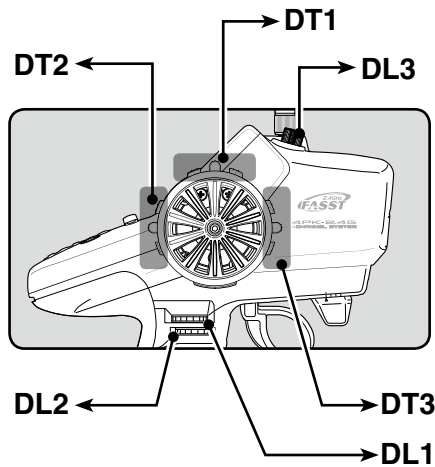

Abbreviation displayed on start screen

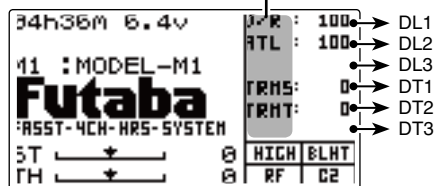

Settable functions (DL1/DL2/DL3, DT1/DT2/DT3)

Abbreviation used on setup screen	Abbreviation displayed on opening screen	Function name, etc
D/R	(D/R)	Dual rate function
ATL	(ATL)	ATL function
EXP-S	(EXPS)	Steering EXP
EXP-F	(EXPF)	Throttle EXP (Forward side)
EXP-B	(EXPB)	Throttle EXP (Brake side)
EXP-3	(EXP3)	3rd Channel brake EXP
EXP-4	(EXP4)	4th Channel brake EXP
SP-TN	(SPTn)	Steering speed (Turn side)
SP-RN	(SPRn)	Steering speed (Return side)
AB.P	(AB.P)	A.B.S. function (Return amount)
ABS.D	(ABSD)	A.B.S. function (Delay)
CYCLE	(CYCL)	A.B.S. function (cycle speed)
ACC-F	(ACCF)	Throttle acceleration (Forward side)
ACC-B	(ACCB)	Throttle acceleration (Brake side)
ACC-3	(ACC3)	3rd Channel brake acceration (BRAKE function-ON)
ACC-4	(ACC4)	4th Channel brake acceration (BRAKE function-ON)
THSP1	(THS1)	Throttle speed (ALL/LOW)
THSP2	(THS2)	Throttle speed (MID)
THSP3	(THS3)	Throttle speed (HIGH)
ST-TR	(TRMS)	Steering trim
TH-TR	(TRMT)	Throttle trim
CH3	(3CH)	Channel 3
CH4	(4CH)	Channel 4
SUBT1	(SBT1)	Sub trim (CH1)
SUBT2	(SBT2)	Sub trim (CH2)
SUBT3	(SBT3)	Sub trim (CH3)
SUBT4	(SBT4)	Sub trim (CH4)
IIDLE	(IDLE)	Idle up function
TLT13	(TL13)	Tilt mixing (1>3)
TLT31	(TL31)	Tilt mixing (3>1)
PM1-A	(PM1A)	Program mixing 1 (RGHT/BRAK/DOWN sides)
PM1-B	(PM1B)	Program mixing 1 (LEFT/FWRD/UP sides)
PM2-A	(PM2A)	Program mixing 2 (RGHT/BRAK/DOWN sides)
PM2-B	(PM2B)	Program mixing 2 (LEFT/FWRD/UP sides)
B3-RT	(B3RT)	Brake mixing (3ch brake rate)
B3-DL	(B3DL)	Brake mixing (3ch delay)
B3ABP	(B3AP)	3rd Channel A.B.S -Return amount (BRAKE function-ON)
B3ABD	(B3AD)	3rd Channel A.B.S -Delay (BRAKE function-ON)
B4-RT	(B4RT)	Brake mixing (4th brake rate)
B4-DL	(B4DL)	Brake mixing (4ch delay)
B4ABP	(B4AP)	4th Channel A.B.S -Return amount (BRAKE function-ON)
B4ABD	(B4AD)	4th Channel A.B.S -Delay (BRAKE function-ON)
B34RT	(B4AD)	Brake mixing (3ch & 4th brake rate)
OFF		Not used

Function

Timer Function "TIMER"

Use the timer by selecting one of the four timers UP TIMER, DOWN TIMER, LAP TIMER and LAP NAVIGATE timer.

UP TIMER function

- The UP TIMER can be used to count the time between start and stop, etc.
- The timer repeatedly starts and stops each time the switch is operated and accumulates the time between each start and stop. (When the count reaches 99 minutes 59 seconds, it returns to 00 minutes 00 seconds and repeats the count.)
- The first start operation can be linked to the throttle trigger.
- An alarm sound can be set. The passage of time is announced by sounding of a buzzer (beeps) each minute after starting.
 - Alarm :Generates a beep at the set time (minutes).
 - Prealarm :Alarm advance announcement sound. Sounding starts the set time (seconds) before the alarm. (beeps)
- After starting, the timer is enabled and can be stopped by switch even when the display switches to another screen.

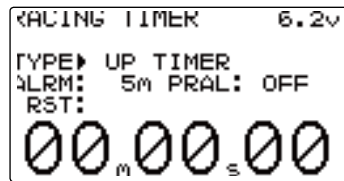

FUEL DOWN TIMER function

The fuel down timer is used primarily to check the refueling time of gasoline engine cars. (The remaining time is displayed.)

- Each time the switch is pressed, the timer is restarted and the set time is counted down. The start time becomes the alarm set time. (When counted down to 00 minutes 00 seconds, the timer becomes an up timer.)
- The fuel down timer can be initially started by throttle trigger.
- An audible alarm can be set. In addition, the passing of time is indicated by sounding of a buzzer each minute after starting.
 - Alarm :Buzzer sounds at the set time (minute).
 - Prealarm :Alarm advance notice sound. Beeping begins the set time (seconds) before the alarm.
- After starting, the timer continues to count even if the LCD switches to another screen.

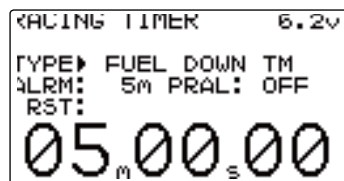

LAP TIMER

LAP TIMER function

- The LAP TIMER can memorize each lap time of each switch operation. (98 laps)
- The race time can be set. Switch operation after the set time by alarm has elapsed automatically stops the timer.. Prealarm can also be set. The passage of time is announced by sounding of a buzzer (beeps) each minute after starting.

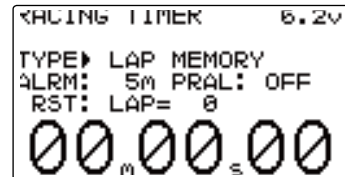

- Alarm :Generates a beep at the set time.
- Prealarm :Starts sounding the set time (second) before the alarm. (beeps)

- The first start operation can be linked with the throttle trigger.

(LAP TIMER operation)

- When lap timer is selected, the number of laps (LAP) and the lap memory No. (No.) and current lap time (TIME) are displayed on the setup screen.

- Number of laps (LAP):Counts up each time the switch is pressed after starting. The numbers blink for 3 seconds after the switch was pressed. To prevent erroneous counting, switch operation is not accepted during this period..

- Lap memory No. (No.):Each lap time is memorized in a lap memory. The lap times are written sequentially from the number after the preceding data. After lap memory "No. 100", the lap No. returns to "No. 1".

- The lap time data memorized in the lap memory can be checked at the lap list (See p. 97) screen.

- Lap time (TIME):During the first 3 seconds, the last lap time is displayed and then the current lap time is displayed. At starting, "0" is displayed for 3 seconds.

LAP NAVIGATE timer

LAP NAVIGATE timer function

- This function sounds a buzzer at a fixed interval after the timer starts. Since only the buzzer can be restarted when the switch is pressed during timer operation, this function can be used as the training run, etc. target time. (Lap navigation alarm) The passage of time is announced by sounding of a buzzer (beeps) every minute after starting.

- The first start operation can be linked with the throttle trigger.

- The alarm sounds (alarm/prealarm) can be set separately from the fixed interval buzzer.

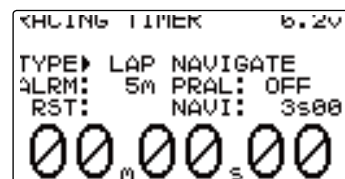

- Alarm :Generates a beep at the set time (minutes).
- Prealarm :Alarm advance announcement sound. Sounding starts the set time (seconds) before the alarm. (beeps)

- After starting, the timer is enabled and can be stopped by switch even when the display switches to another screen.

Calling the setup screen

*Calling from menu screen

(Opening Screen)

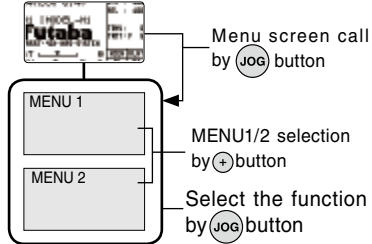

Press the (JOG) button

* When the direct call button is set, the setup screen is also called by the following method:

(Opening Screen)

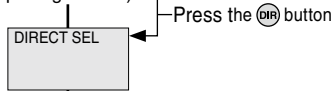

Press the button set at this function.

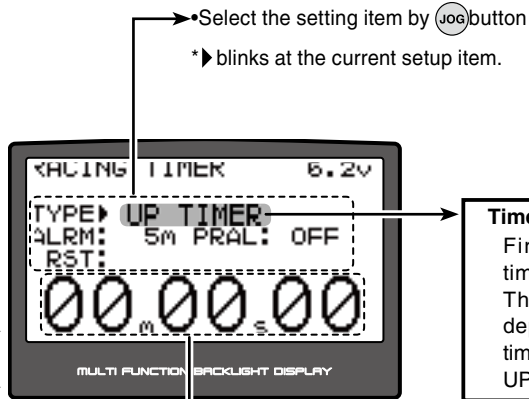

*Select the setting item by (JOG) button

*▶ blinks at the current setup item.

Timer selection
First, select the type of timer at the "TYPE" item. The setup screen varies depending on the type of timer. This figure shows the UP TIMER setup screen.

Time display
Minute display (m)
Second display (s)
1/100 second display

Operation display

While the TIMER function is operating, **TIM** is displayed on the initial screen and menu screen.

Racing timer type selection

(Preparation)

Assign the "LAP START" switch using the function select switch (p.86). When resetting by switch, assign "LAP RESET" also.

1 (Racing timer type selection)

Select the setting item "TYPE" by (JOG) button up, down, left, or right operation. Press the (+) or (-) button and set the racing timer type.

Timer selection (TYPE)
UP TIMER : Up timer
DOWN TIMER : Down timer
LAP MEMORY : Lap timer
LAP NAVIGATE : Navigate timer

Setup item selection

- Select by (JOG) button up, down, left or right operation.

Adjustment buttons

- Use the (+) and (-) buttons to make adjustments.

2 When ending setting, return to the initial screen by pressing the (END) button twice (for function menu screen, press the (END) button once).

Using the up timer

(Preparation)

Select the setting item "TYPE" by (JOG) button up or down operation. Press the (+) or (-) button and select "UP TIMER".

1 (Alarm time setting)

Select the setting item "ALRM" by (JOG) button up, down, left, or right operation and set the alarm time with the (+) and (-) buttons.

(Pre alarm time setting)

Select the setting item "PRAL" by (JOG) button up, down, left, or right operation, and set the pre alarm time with the (+) and (-) buttons.

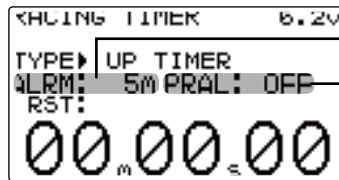

Adjustment buttons

- Use the (+) and (-) buttons to make adjustments.
- Press the (+) and (-) buttons simultaneously (approx. 1 sec) to return to the initial screen.

Alarm time (ALRM)

OFF, 1 ~ 99 m
Initial value: 5 m

Prealarm time (PRAL)

OFF, 1 ~ 30 s
Initial value: OFF

2 (Timer start/stop operation)

When the switch ("LAP START") assigned by function select switch function is pressed, the timer starts. Stop the timer with the same switch ("LAP START") as start, or with the switch assigned the "LAP RE-SET" function.

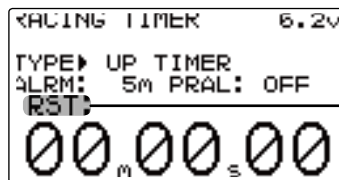

Status display

RST :Reset state
RDY :Throttle trigger operation wait
RUN :Timer running
STP :Timer stopped

- Linking only start to the throttle trigger

Select the setting item "RST" by (JOG) button up, down, left, or right operation and press the (+) and (-) buttons simultaneously for about 1 second. When the set beeps and the status display switches from "RST" to blinking "RDY", the system enters the trigger operation ready state. When the trigger is operated at the forward side, the timer starts. (Status display "RUN")

Switches

LAP START :start / stop
LAP RESET :stop / reset

3 (Timer reset operation)

When the switch ("LAP RESET") assigned by function select switch function is pressed, the timer is reset. Select the status display ("RUN", "STP", or "RDY") by (JOG) button up or down operation and press the (+) and (-) buttons simultaneously for about 1 second. The set beeps and the status display changes to "RST" and the timer resets.

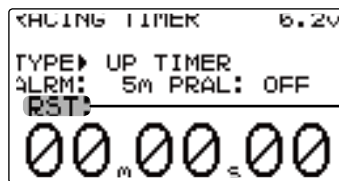

Status display

RST :Reset state
RDY :Throttle trigger operation wait
RUN :Timer running
STP :Timer stopped

Using the fuel down timer

(Preparation)

Select the setting item "TYPE" by (JOG) button up or down operation. Press the (+) or (-) button and select "FUEL DOWN TM".

1 (Alarm time setting)

Select the setting item "ALRM" by (JOG) button up, down, left, or right operation and set the alarm time with the (+) and (-) buttons.

(Pre alarm time setting)

Select the setting item "PRAL" by (JOG) button up, down, left, or right operation, and set the pre alarm time with the (+) and (-) buttons.

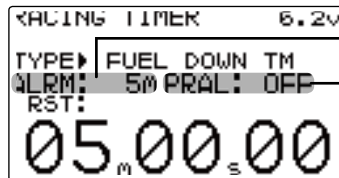

Adjustment buttons

- Use the (+) and (-) buttons to make adjustments.
- Press the (+) and (-) buttons simultaneously (approx. 1 sec) to return to the initial screen.

Alarm time (ALRM)

OFF, 1 ~ 99 m
Initial value: 5 m

Prealarm time (PRAL)

OFF, 1 ~ 30 s
Initial value: OFF

2 (Timer start/stop operation)

When the switch ("LAP START") assigned by function select switch function is pressed, the timer starts. When the switch ("LAP START") is pressed while the timer is operating, the timer is reset and simultaneously restarted. (Restart)

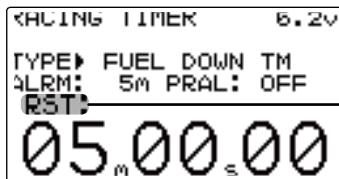

Status display

RST :Reset state
RDY :Throttle trigger operation wait
RUN :Timer running
STP :Timer stopped

- Linking only start to the throttle trigger

Select the setting item "RST" by (JOG) button up, down, left, or right operation and press the (+) and (-) buttons simultaneously for about 1 second. When the set beeps and the status display switches from "RST" to blinking "RDY", the system enters the trigger operation ready state. When the trigger is operated at the forward side, the timer starts. (Status display "RUN")

Switches

LAP START :start / stop
LAP RESET :stop / reset

3 (Timer stop and reset operation)

When the switch ("LAP RESET") assigned by function select switch function is pressed, the timer is stopped and reset. Select the status display ("RUN", "STP", or "RDY") by (JOG) button up or down operation and press the (+) and (-) buttons simultaneously for about 1 second. The set beeps and the status display changes to "RST" and the timer resets.

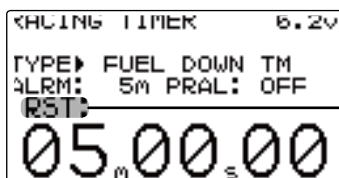

Status display

RST :Reset state
RDY :Throttle trigger operation wait
RUN :Timer running
STP :Timer stopped

Using the Lap timer timer

(Preparation)

Select the setting item "TYPE" by (JOG) button up or down operation. Press the (+) or (-) button and select "LAP MEMORY".

1 (Alarm time setting)

Select the setting item "ALRM" by (JOG) button up, down, left, or right operation and set the alarm time with the (+) and (-) buttons.

(Pre alarm time setting)

Select the setting item "PRAL" by (JOG) button up, down, left, or right operation, and set the pre alarm time with the (+) and (-) buttons.

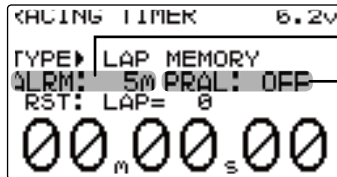

Adjustment buttons

- Use the (+) and (-) buttons to make adjustments.
- Press the (+) and (-) buttons simultaneously (approx. 1 sec) to return to the initial screen.

Alarm time (ALRM)

OFF, 1 ~ 99 m
Initial value: 5 m

Prealarm time (PRAL)

OFF, 1 ~ 30 s
Initial value: OFF

2 (Timer start/lap count operation)

Perform the start and lap count operations with the switch ("LAP START") assigned by function select switch function.

- Linking only start to the throttle trigger

Select the setting item "RST" by (JOG) button up, down, left, or right operation and press the (+) and (-) buttons simultaneously for about 1 second. The set beeps and the timer display changes from "RST" to blinking "RDY" and the set enters the trigger operation ready state. (Status display "RUN")

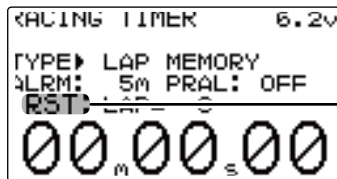

Status display

RST :Reset state
RDY :Throttle trigger operation wait
RUN :Timer running
STP :Timer stopped

Switches

LAP START :start / lap count
LAP RESET :stop / reset

3 (Timer stop/reset operation)

When the lap count switch ("LAP START") is pressed after the time set with "ALRM" has elapsed, the timer stops and the lap time, total time, and average time are memorized.

When the switch ("LAP RESET") is pressed, the timer is reset.

When a switch is not assigned, select the status display ("RUN", "STP", or "RDY") by (JOG) button up or down operation and press the (+) or (-) buttons simultaneously for about 1 second. The set beeps and the timer display changes to "RST" and the timer resets.

- When the timer was stopped with the switch assigned the "LAP RESET" function before the set "ALRM" time has elapsed, the total time and average time are not memorized.

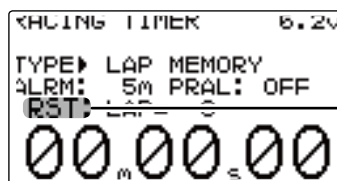

Status display

RST :Reset state
RDY :Throttle trigger operation wait
RUN :Timer running
STP :Timer stopped

Function

Using the navigate timer

(Preparation)

Select the setting item "TYPE" by (JOG) button up or down operation. Press the (+) or (-) button and select "NAVIGATE".

1 (Alarm time setting)

Select the setting item "ALRM" by (JOG) button up, down, left, or right operation and set the alarm time with the (+) and (-) buttons.

(Pre alarm time setting)

Select the setting item "PRAL" by (JOG) button up, down, left, or right operation and set the pre alarm time with the (+) and (-) buttons.

(Lap navigation time setting)

Select the setting item "NAVI" by (JOG) button up, down, left, or right operation and set the lap navigation alarm (target) time with the (+) and (-) buttons.

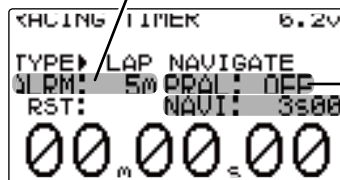

Adjustment buttons

- Use the (+) and (-) buttons to make adjustments.
- Press the (+) and (-) buttons simultaneously (approx. 1 sec) to return to the initial screen.

Alarm time (ALRM)

OFF, 1 ~ 99 m
Initial value: 8 m

Prealarm time (PRAL)

OFF, 1 ~ 30 s
Initial value: OFF

Navi alarm time (NAVI)

OFF, 1 ~ 30 s
Initial value: 3 s

2 (Timer start/navigation restart operation)

When the switch ("LAP START") assigned by function select switch function is pressed, the timer starts.

- Linking only start to the throttle trigger

Select the setting item "RST" by (JOG) button up, down, left, or right operation and press the (+) and (-) buttons simultaneously for about 1 second. The set beeps and the status displays changes from "RST" to blinking "RDY" and the set enters the trigger operation ready state. When the trigger is operated at the forward side, the timer starts. (Status display "RUN")

- When your own lap time is less than the target time and the lap counts overlap, the lap navigation alarm timing is too big. The alarm timing can be corrected by pressing the switch ("LAP START") during measurement.

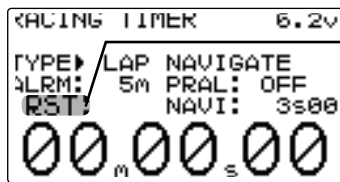

Status display

RST :Reset state
RDY :Throttle trigger operation wait
RUN :Timer running
STP :Timer stopped

Switches

LAP START :start/navi restart
LAP RESET :stop/reset

3 (Timer stop/reset operation)

When the switch ("LAP RESET") assigned by function select switch function is pressed, the timer stops. Re-set the timer by pressing the "LAP RESET" switch.

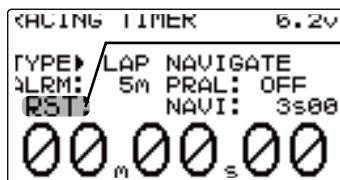

Status display

RST :Reset state
RDY :Throttle trigger operation wait
RUN :Timer running
STP :Timer stopped

When a switch is not assigned, select the status display ("RUN" or "RDY") by (JOG) button up or down operation and press the (+) and (-) buttons simultaneously for about 1 second. The set beeps and the timer resets. (Does not pause)

Lap List "LAP-L"

Call LAP-LIST when checking the lap memory data (each lap time) memorized by lap timer (page 90, 95) operation.

- After the lap timer is started, the lap time is sequentially memorized at each switch operation.

When set time of ALRM passes and the timer is stopped, the last lap is memorized and the total time is automatically written after the last lap and the average lap is automatically written after that.

-The next Lap-Timer starts at the lap memory number following the average lap (AVE).

Calling the setup screen

*Calling from menu screen

(Opening Screen)

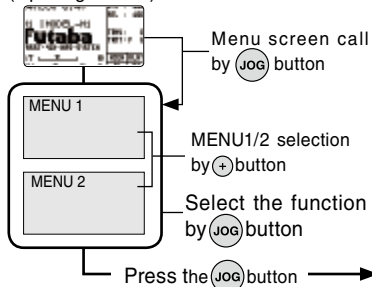

* When the direct call button is set, the setup screen is also called by the following method:

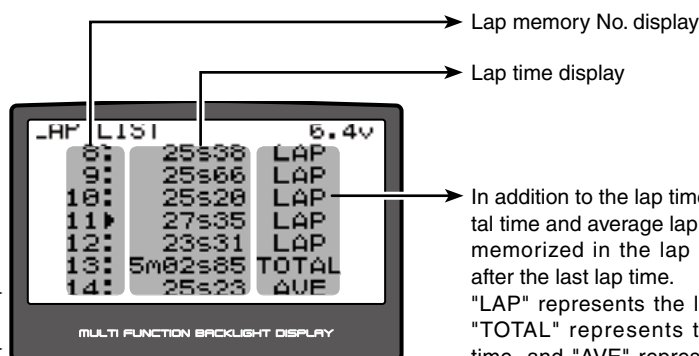
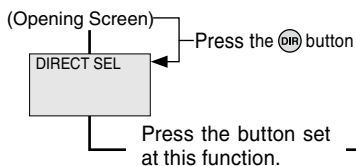

In addition to the lap time, the total time and average lap time are memorized in the lap memory after the last lap time. "LAP" represents the lap time, "TOTAL" represents the total time, and "AVE" represents the average lap.

Using the lap memory

1 (Lap memory check)

The cursor can be scrolled and each lap time checked by (JOG) button up or down operation.

2 (Lap memory reset)

Select the lap memory No. by (JOG) button up or down operation and press the (+) and (-) buttons simultaneously for about 1 second. The set beeps and the lap memory of the selected lap memory No. resets.

(Resetting all the lap memory data)

While pressing the (JOG) button, press the (+) and (-) buttons simultaneously for about 1 second. The set beeps and all the data resets.

3 When ending setting, return to the initial screen by pressing the (END) button twice (for function menu screen, press the (END) button once).

Model Selection "M-SEL"

Forty model data (model data for 40 R/C cars) can be saved in the 4PK transmitter and used when the relevant model data is called.

Calling the setup screen

*Calling from menu screen

(Opening Screen)

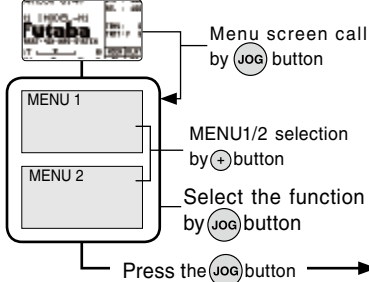

* When the direct call button is set, the setup screen is also called by the following method:

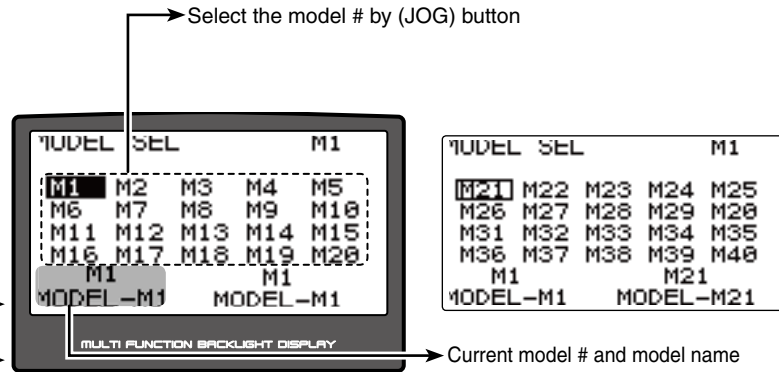
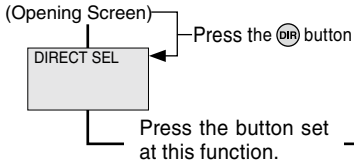

When changing the receiver type and servo response to a different model (FASS-C1, FASST-C2, or HIGH SPEED, NORMAL)

When the type was changed to a different model, signals are output by previous model type until the transmitter power is turned off. Use after turning the transmitter power off and on.

Using the model selection function

1 (Model No. selection)

Select the model No. by (JOG) button up, down, left, or right operation. When the up (JOG) button is operated from the "M1" ~ "M5" cursor position on the top line or the down (JOG) button is operated from the "M16" ~ "M20" cursor position on the bottom line, "M21" ~ "M40" is displayed. Perform the same operation to display the model numbers "M1" ~ "M40" from "M21" ~ "M40".

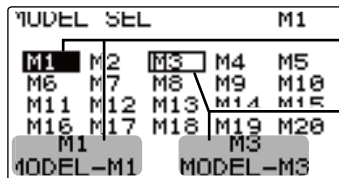

Model #.
M1-M40

Model selection button

- Select the model by (JOG) button up, down, left, or right operation.

2 (Model selection execution)

Press the (+) and (-) buttons simultaneously for about 1 second. A beeping sound is generated and the model is selected.

- Model selection is complete when the model No. and model name at the bottom left of the screen change.

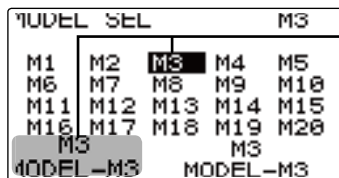

Modified model # and model name

Model selection set button

- (+) and (-) buttons pressed simultaneously for about 1 second.

3 When ending setting, return to the initial screen by pressing the (END) button twice (for function menu screen, press the (END) button once).

Model Name "NAME"

This function allows you to assign a ten character name to each model memory and an user name (ten character).

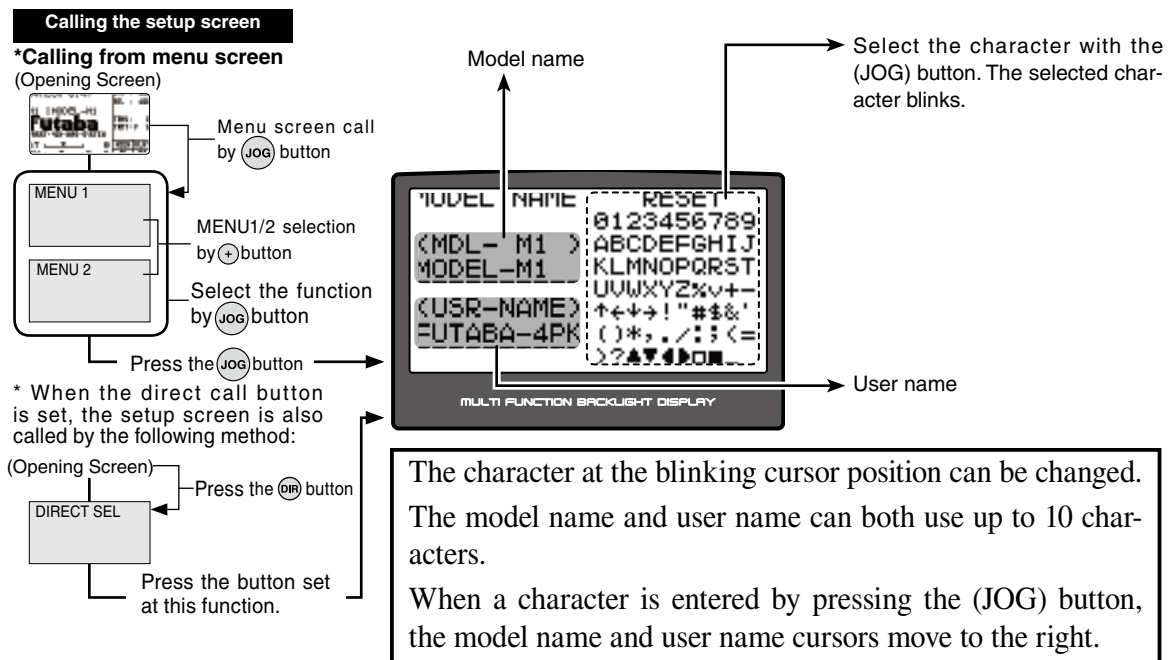

Setting the model name and user name

- 1** (Moving the cursor to the character you want to change)
Move the cursor to the model name or user name character you want to set or change by pressing the (+) or (-) button. The selected character blinks.
- 2** (Selecting the character to be used)
Select the character to be used from the character list at the right-hand side of the screen by (JOG) button up, down, left, or right operation. The selected character blinks. After selecting the character to be used, press the (JOG) button. The character is entered and the model name or user name character row moves to the right.

When "RESET" on the top row of the character list is selected and the (JOG) button is pressed, the model name or user name is initialized to the factory setting.
- 3** When ending setting, return to the initial screen by pressing the (END) button twice (for function menu screen, press the (END) button once).

Character select/set button

- Select the character by (JOG) button up, down, left, or right operation and enter the character by pressing the (JOG) button.

Initialization

Model name :MODEL-M (#)

User name :FUTABA-4PK

Model Copy "M-COP"

The contents of the model memory can be copied to another model memory.

Single mode (SINGLE) and group mode (GROUP)

Single mode copies the data to another model in model units.

Group mode groups M1~M10, M11~M20, M21~M30, and M31~M40 into individual groups and copies the data from group to group. For example, it is a convenient function in order to batch copy the data of M1~M10 to M11~M20.

Menu copy (MENU COPY) and switch/dial copy (SW/DIAL COPY)

Menu copy copies the menu type selected by menu selection (page 103) or a customized menu and direct menu. Setting data is not copied. It is a convenient function in order to copy only menus without changing the setting data of a model.

Switch/dial copy copies the operation functions set by function select switch and function select dial. Setting data is not copied. It is a convenient function in order to copy only the function select switch and function select dial set by model.

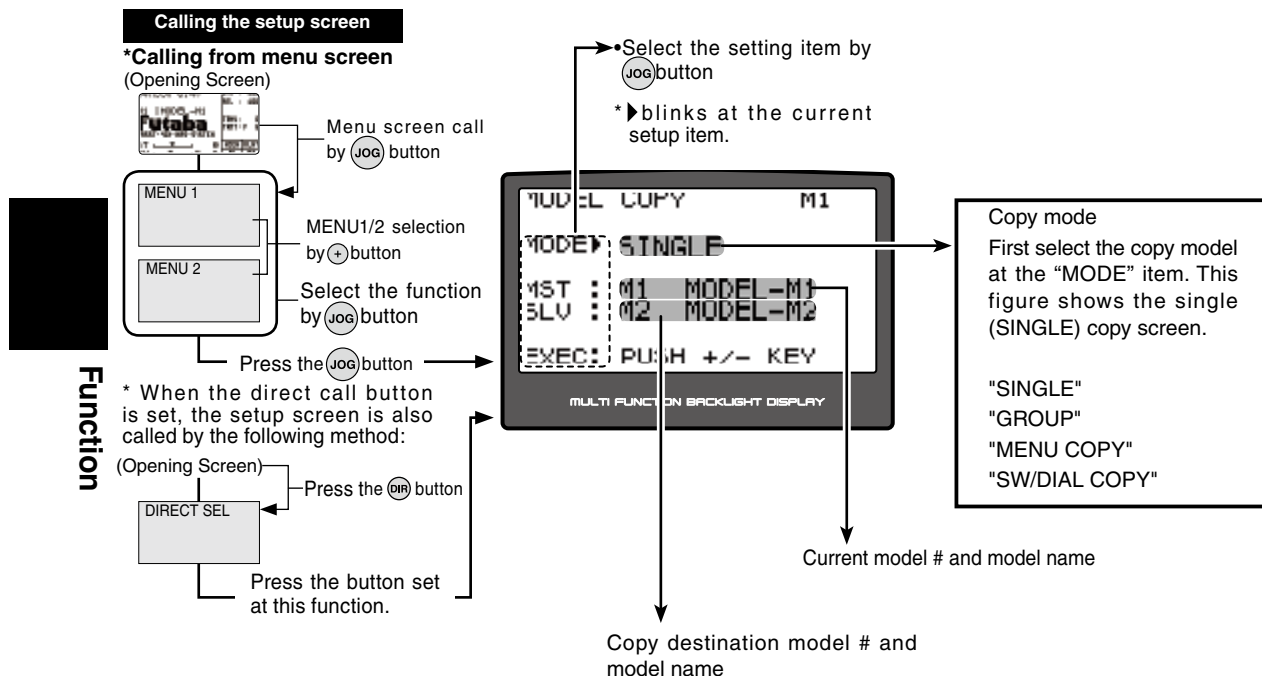

```

MODEL COPY      M1
MODE▶ SINGLE
MST : M1  MODEL-M1
SLV : M2  MODEL-M2
EXEC: PUSH +/- KEY

```

"SINGLE" mode

```

MODEL COPY      M1
MODE▶ GROUP
MST : M1 ~ M10
SLV : M11 ~ M20
EXEC: PUSH +/- KEY

```

"GROUP" mode

```

MODEL COPY      M1
MODE▶ MENU COPY
MST : M1  MODEL-M1
SLV : M2  MODEL-M2
EXEC: PUSH +/- KEY

```

"MENU COPY" mode

```

MODEL COPY      M1
MODE▶ SW/DIAL COPY
MST : M1  MODEL-M1
SLV : M2  MODEL-M2
EXEC: PUSH +/- KEY

```

"SW/DIAL COPY" mode

Model copying

(Preparation)

Select setting item "MODE" by (JOG) button up or down operation and select the copy mode from "SINGLE", "GROUP", "MENU COPY", and "SW/DIAL COPY" by pressing the (+) or (-) button.

- When executing the model copy function, always select the copy mode first. If the copy mode is changed after the copy source (MST) and copy destination (STV) models were decided, it may become necessary to re-select MST and SLV because the copy source (MST) and copy destination (SLV) models return to the M1~M2 initial value.

1 (Copy source model No. selection)

Select the setting item "MST" by (JOG) button up or down operation. Press the (+) or (-) button and select the model #.

2 (Copy destination model No. selection)

Select the setting item "SLV" by (JOG) button up or down operation. Press the (+) or (-) button and select the model #.

- For the model currently in use (including group), "CAN NOT COPY" blinks at the bottom of the screen to alert the operator that the model cannot be copied.

3 (Copy execution)

Select the setting item "EXEC" by (JOG) button up or down operation. Press the (+) and (-) buttons simultaneously for 1 second. When "COMPLETE!" blinks at the bottom of the screen, copying is complete.

4 When ending setting, return to the initial screen by pressing the (END) button twice (for function menu screen, press the (END) button once).

Setup item selection

- Select by (JOG) button up or down operation.

Model number selection

- Use the (+) and (-) buttons to make adjustments.

Model No.

M1~M40

Copy execution button

- (+) and (-) buttons pressed simultaneously for about 1 second.

Function

Model Reset "M-RES"

This function resets the contents of the currently called model memory.

The reset method can be selected from among the 3 types described below. These resets do not initialize the adjuster function (ADJST), system function (SYSTM), lap reset (LAP-L), user name (NAME), and receiver type (FASST-C1/FASST-C2), servo response selection function (RXSYS).

DATA RESET

Initializes only the function setting data. The menu function and direct selection function are not initialized.

MENU RESET

Initializes the menu function and direct selection function. Other settings are not initialized.

ALL RESET

Initializes the menu function, direct selection function, and the setting data of each function.

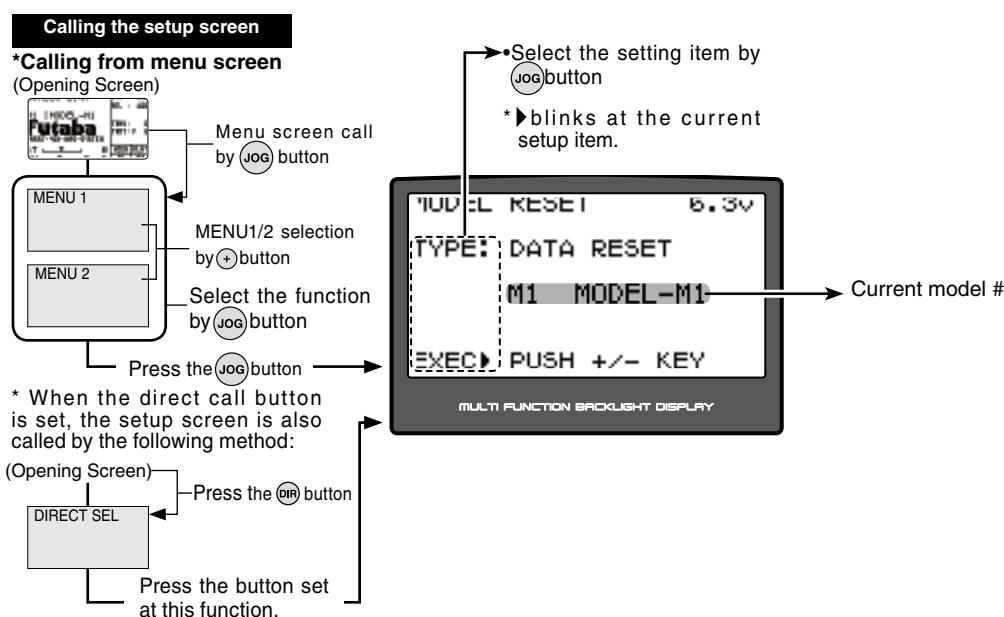

Model Reset

Select the setting item "TYPE" by (JOG) button up or down operation and press the (+) or (-) button and select the reset type from among "DATA RESET", "MENU RESET", and "ALL RESET".

1 (Reset execution)

Select the setting item "EXEC" by (JOG) button up or down operation.

Press the (+) and (-) buttons simultaneously for 1 second.

When "COMPLETE!" blinks at the bottom of the screen, memory resetting is complete.

2 When ending setting, return to the initial screen by pressing the (END) button twice (for function menu screen, press the (END) button once).

Setup item selection

- Select by (JOG) button up or down operation.

Reset type selection

- Use the (+) and (-) buttons to make adjustments.

Type (TYPE)

DATA RESET
MENU RESET
ALL RESET

Reset execution button

- (+) and (-) buttons pressed simultaneously for about 1 second.

Menu Type Selection "MENU-T"

The function selection menu matched to the level of use can be selected from among the 4 types shown below. (The menu type can be set for each model.)

LEVEL1	LEVEL2	BIGCAR	LEVEL3	ALLOFF																																																																																																																																														
<table border="1"> <tr><td>MENU 1</td><td>UP</td></tr> <tr><td>█</td><td></td></tr> <tr><td>EPA</td><td>RXSYS</td><td>SYSTEM</td><td></td><td></td></tr> <tr><td>REV</td><td>F/S</td><td>*M-SEL</td><td></td><td></td></tr> <tr><td>SUBTR</td><td>NAME</td><td>*M-RES</td><td></td><td></td></tr> <tr><td></td><td></td><td>*MFNIL-T</td><td></td><td></td></tr> </table>	MENU 1	UP	█		EPA	RXSYS	SYSTEM			REV	F/S	*M-SEL			SUBTR	NAME	*M-RES					*MFNIL-T			<table border="1"> <tr><td>MENU 1</td><td>UP</td></tr> <tr><td>█</td><td></td></tr> <tr><td>STEXP</td><td>EPA</td><td>SYSTEM</td><td></td><td></td></tr> <tr><td>THEXP</td><td>SUBTR</td><td>NAME</td><td></td><td></td></tr> <tr><td>IDLUP</td><td>REV</td><td>*M-SEL</td><td></td><td></td></tr> <tr><td>A.B.S</td><td>RXSYS</td><td>*M-RES</td><td></td><td></td></tr> <tr><td>START</td><td>F/S</td><td>*MFNIL-T</td><td></td><td></td></tr> </table>	MENU 1	UP	█		STEXP	EPA	SYSTEM			THEXP	SUBTR	NAME			IDLUP	REV	*M-SEL			A.B.S	RXSYS	*M-RES			START	F/S	*MFNIL-T			<table border="1"> <tr><td>MENU 1</td><td>UP</td></tr> <tr><td>█</td><td></td></tr> <tr><td>BRAKE</td><td>SUBTR</td><td>SYSTEM</td><td></td><td></td></tr> <tr><td>A.B.S</td><td>REV</td><td>NAME</td><td></td><td></td></tr> <tr><td>EPA</td><td>RXSYS</td><td>*M-SEL</td><td></td><td></td></tr> <tr><td>STEXP</td><td>F/S</td><td>*M-RES</td><td></td><td></td></tr> <tr><td>THEXP</td><td></td><td>*MFNIL-T</td><td></td><td></td></tr> </table>	MENU 1	UP	█		BRAKE	SUBTR	SYSTEM			A.B.S	REV	NAME			EPA	RXSYS	*M-SEL			STEXP	F/S	*M-RES			THEXP		*MFNIL-T			<table border="1"> <tr><td>MENU 1</td><td>2</td><td>UP</td></tr> <tr><td>█</td><td></td><td></td></tr> <tr><td>STEXP</td><td>EPA</td><td>TIMER</td><td></td><td></td></tr> <tr><td>STSPD</td><td>ACCEL</td><td>LAP-L</td><td></td><td></td></tr> <tr><td>THEXP</td><td>START</td><td>BOAT</td><td></td><td></td></tr> <tr><td>THSPD</td><td>IDLUP</td><td>*M-SEL</td><td></td><td></td></tr> <tr><td>BRAKE</td><td>PMIX1</td><td>*M-RES</td><td></td><td></td></tr> <tr><td>A.B.S</td><td>PMIX2</td><td>*MFNIL-T</td><td></td><td></td></tr> </table>	MENU 1	2	UP	█			STEXP	EPA	TIMER			STSPD	ACCEL	LAP-L			THEXP	START	BOAT			THSPD	IDLUP	*M-SEL			BRAKE	PMIX1	*M-RES			A.B.S	PMIX2	*MFNIL-T			<table border="1"> <tr><td>MENU 1</td><td>UP</td></tr> <tr><td>█</td><td></td></tr> <tr><td></td><td></td><td></td><td></td><td></td></tr> <tr><td></td><td></td><td></td><td></td><td>*M-SEL</td></tr> <tr><td></td><td></td><td></td><td></td><td>*M-RES</td></tr> <tr><td></td><td></td><td></td><td></td><td>*MFNIL-T</td></tr> </table>	MENU 1	UP	█											*M-SEL					*M-RES					*MFNIL-T
MENU 1	UP																																																																																																																																																	
█																																																																																																																																																		
EPA	RXSYS	SYSTEM																																																																																																																																																
REV	F/S	*M-SEL																																																																																																																																																
SUBTR	NAME	*M-RES																																																																																																																																																
		*MFNIL-T																																																																																																																																																
MENU 1	UP																																																																																																																																																	
█																																																																																																																																																		
STEXP	EPA	SYSTEM																																																																																																																																																
THEXP	SUBTR	NAME																																																																																																																																																
IDLUP	REV	*M-SEL																																																																																																																																																
A.B.S	RXSYS	*M-RES																																																																																																																																																
START	F/S	*MFNIL-T																																																																																																																																																
MENU 1	UP																																																																																																																																																	
█																																																																																																																																																		
BRAKE	SUBTR	SYSTEM																																																																																																																																																
A.B.S	REV	NAME																																																																																																																																																
EPA	RXSYS	*M-SEL																																																																																																																																																
STEXP	F/S	*M-RES																																																																																																																																																
THEXP		*MFNIL-T																																																																																																																																																
MENU 1	2	UP																																																																																																																																																
█																																																																																																																																																		
STEXP	EPA	TIMER																																																																																																																																																
STSPD	ACCEL	LAP-L																																																																																																																																																
THEXP	START	BOAT																																																																																																																																																
THSPD	IDLUP	*M-SEL																																																																																																																																																
BRAKE	PMIX1	*M-RES																																																																																																																																																
A.B.S	PMIX2	*MFNIL-T																																																																																																																																																
MENU 1	UP																																																																																																																																																	
█																																																																																																																																																		
				*M-SEL																																																																																																																																														
				*M-RES																																																																																																																																														
				*MFNIL-T																																																																																																																																														
<table border="1"> <tr><td>MENU 2</td><td>UP</td></tr> <tr><td>█</td><td></td></tr> <tr><td>STEXP</td><td>DIAL</td><td>MCLNK</td><td></td><td></td></tr> <tr><td>THEXP</td><td>SWTCH</td><td>ADJST</td><td></td><td></td></tr> <tr><td>A.B.S</td><td>BOAT</td><td>THMOD</td><td></td><td></td></tr> <tr><td>M-COP</td><td>DTTRN</td><td>UIBRA</td><td></td><td></td></tr> </table>	MENU 2	UP	█		STEXP	DIAL	MCLNK			THEXP	SWTCH	ADJST			A.B.S	BOAT	THMOD			M-COP	DTTRN	UIBRA			<table border="1"> <tr><td>MENU 2</td><td>UP</td></tr> <tr><td>█</td><td></td></tr> <tr><td>STSPD</td><td>DIAL</td><td>DTTRN</td><td></td><td></td></tr> <tr><td>THSPD</td><td>SWTCH</td><td>MCLNK</td><td></td><td></td></tr> <tr><td>ACCEL</td><td>TIMER</td><td>ADJST</td><td></td><td></td></tr> <tr><td>START</td><td>LAP-L</td><td>THMOD</td><td></td><td></td></tr> <tr><td>M-COP</td><td>SERVO</td><td>UIBRA</td><td></td><td></td></tr> </table>	MENU 2	UP	█		STSPD	DIAL	DTTRN			THSPD	SWTCH	MCLNK			ACCEL	TIMER	ADJST			START	LAP-L	THMOD			M-COP	SERVO	UIBRA			<table border="1"> <tr><td>MENU 2</td><td>UP</td></tr> <tr><td>█</td><td></td></tr> <tr><td>STSPD</td><td>DIAL</td><td>DTTRN</td><td></td><td></td></tr> <tr><td>THSPD</td><td>SWTCH</td><td>SERVO</td><td></td><td></td></tr> <tr><td>ACCEL</td><td>PMIX1</td><td>ADJST</td><td></td><td></td></tr> <tr><td>IDLUP</td><td>PMIX2</td><td>THMOD</td><td></td><td></td></tr> <tr><td>M-COP</td><td></td><td>UIBRA</td><td></td><td></td></tr> </table>	MENU 2	UP	█		STSPD	DIAL	DTTRN			THSPD	SWTCH	SERVO			ACCEL	PMIX1	ADJST			IDLUP	PMIX2	THMOD			M-COP		UIBRA			<table border="1"> <tr><td>MENU 2</td><td>1B</td><td>UP</td></tr> <tr><td>█</td><td></td><td></td></tr> <tr><td>SUBTR</td><td>DIAL</td><td>SYSTEM</td><td></td><td></td></tr> <tr><td>REV</td><td>SWTCH</td><td>DTTRN</td><td></td><td></td></tr> <tr><td>M-COP</td><td>D/R</td><td>MCLNK</td><td></td><td></td></tr> <tr><td>NAME</td><td>ATL</td><td>ADJST</td><td></td><td></td></tr> <tr><td>RXSYS</td><td>CH3/4</td><td>THMOD</td><td></td><td></td></tr> <tr><td>F/S</td><td>SERVO</td><td>UIBRA</td><td></td><td></td></tr> </table>	MENU 2	1B	UP	█			SUBTR	DIAL	SYSTEM			REV	SWTCH	DTTRN			M-COP	D/R	MCLNK			NAME	ATL	ADJST			RXSYS	CH3/4	THMOD			F/S	SERVO	UIBRA			<table border="1"> <tr><td>MENU 2</td><td>UP</td></tr> <tr><td>█</td><td></td></tr> <tr><td></td><td></td><td></td><td></td><td></td></tr> <tr><td></td><td></td><td></td><td></td><td></td></tr> <tr><td></td><td></td><td></td><td></td><td></td></tr> </table>	MENU 2	UP	█																					
MENU 2	UP																																																																																																																																																	
█																																																																																																																																																		
STEXP	DIAL	MCLNK																																																																																																																																																
THEXP	SWTCH	ADJST																																																																																																																																																
A.B.S	BOAT	THMOD																																																																																																																																																
M-COP	DTTRN	UIBRA																																																																																																																																																
MENU 2	UP																																																																																																																																																	
█																																																																																																																																																		
STSPD	DIAL	DTTRN																																																																																																																																																
THSPD	SWTCH	MCLNK																																																																																																																																																
ACCEL	TIMER	ADJST																																																																																																																																																
START	LAP-L	THMOD																																																																																																																																																
M-COP	SERVO	UIBRA																																																																																																																																																
MENU 2	UP																																																																																																																																																	
█																																																																																																																																																		
STSPD	DIAL	DTTRN																																																																																																																																																
THSPD	SWTCH	SERVO																																																																																																																																																
ACCEL	PMIX1	ADJST																																																																																																																																																
IDLUP	PMIX2	THMOD																																																																																																																																																
M-COP		UIBRA																																																																																																																																																
MENU 2	1B	UP																																																																																																																																																
█																																																																																																																																																		
SUBTR	DIAL	SYSTEM																																																																																																																																																
REV	SWTCH	DTTRN																																																																																																																																																
M-COP	D/R	MCLNK																																																																																																																																																
NAME	ATL	ADJST																																																																																																																																																
RXSYS	CH3/4	THMOD																																																																																																																																																
F/S	SERVO	UIBRA																																																																																																																																																
MENU 2	UP																																																																																																																																																	
█																																																																																																																																																		

Caution when lowering the level

The set value of the functions removed from the menu when the level was lowered remains effective thereafter. Before lowering the level, turn off the unused functions, and when there is rate adjustment, etc. related to other functions, check the set values.

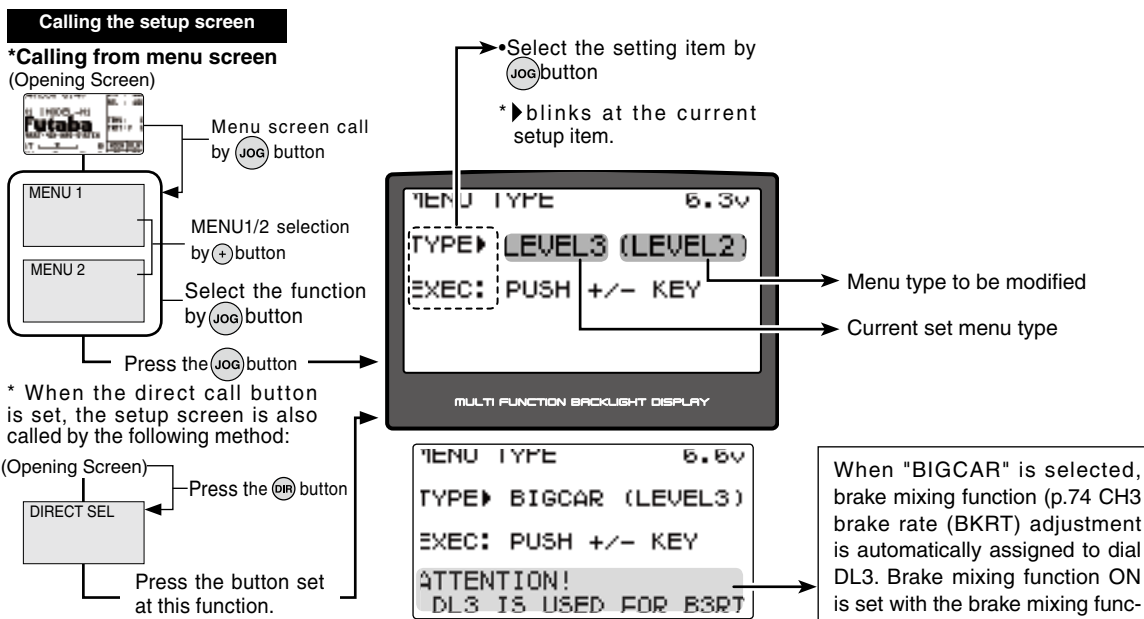

Type selection

- 1 (Menu type selection)**
Select the setting item "TYPE" by (JOG) button up or down operation. Select the menu type with the (+) or (-) button.
- 2 (Menu type change)**
Select the setting item "EXEC" by (JOG) button up or down operation. Press the (+) and (-) buttons simultaneously for 1 second. When the screen display changes, the change is complete.
- 3** When ending setting, return to the initial screen by pressing the (END) button twice (for function menu screen, press the (END) button once).

Type (TYPE)

LEVEL1, LEVEL2, BIGCAR, LEVEL3, ALL OFF

Type change button

- (+) and (-) buttons pressed simultaneously for about 1 second.

Function

ESC Link Function "MCLNK"

This is a special function which lets you set the contents of the Link software which performs Futaba speed controller (ESC), MC850C, MC601C, MC401CR, etc. variable frequency and other data changes by PC at the T4PK transmitter. However, the following MC401CR settings cannot be used with the T4PK MC link function.

Reverse Mode Shift Level

Reverse (back) operation is enabled when once returned from brake operation to neutral. Necessary brake operation amount setting for switching to this reverse operation.

Robot Mode

Setting which cancels the brake function with robot models, etc. and makes it forward and reverse (back) continuous operation.

Reverse Cancel

Setting which cancels the reverse (back) function for forward and brake operation only.

This function is used by connecting ESC directly to the transmitter. The T4PK power switch is used at the display side. Use the various optional servo extension cords according to the distance between the transmitter and ESC.

The last data read from ESC to T4PK or the last data written from T4PK to ESC is saved to the T4PK. Since the data for each model memory can be saved, the data of up to 40 models can be saved.

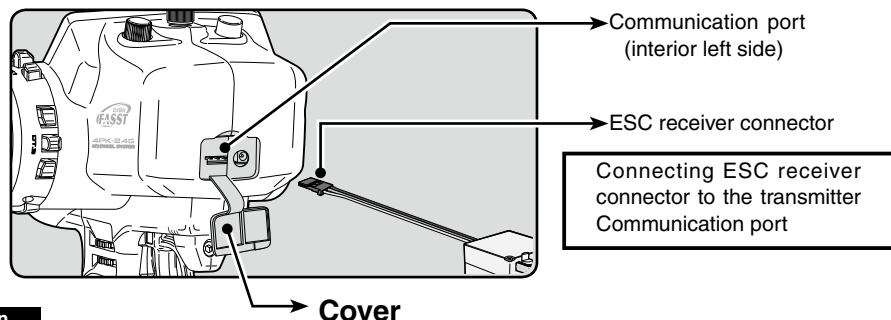

Function

Calling the setup screen

*Calling from menu screen
(Opening Screen)

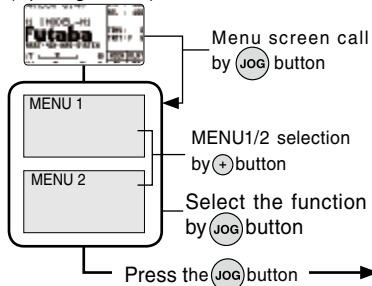

* When the direct call button is set, the setup screen is also called by the following method:

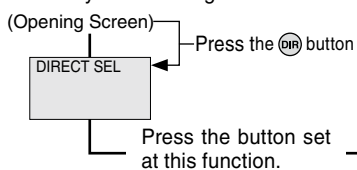

-When the T4PK battery voltage drops, the display switches to low battery display. Therefore, use this function when there is ample battery capacity remaining.
-Also connect the battery at the ESC side.

```
T4 LINK (401CR) 6.4v
MODE: READ (MC->TX)
EXEC: PUSH +/- KEY

IIn:3000|DdR: 15|CLH:300|EHD:100
IRX:2500|LdP:3.0|CTH:300|RHD: 50
nTB: 0|CLT: 0|FWB: 0
```

MC401CR

```
T4 LINK (601C) 6.4v
MODE: READ (MC->TX)
EXEC: PUSH +/- KEY

IIn:2900|DdR: 12|CLH:300|EHD:100
IRX:2500|LdP:3.0|CTH:300|RHD: 50
nTB: 0|CLT: 0|FWB: 20
```

MC601C

```
T4 LINK (850C) 6.4v
MODE: READ (MC->TX)
EXEC: PUSH +/- KEY

IIn:3000|DdR: 12|CLH:300|EHD:100
IRX:2500|LdP:3.0|CTH:300|RHD: 50
nTB: 0|CLT: 0
```

MC850C

Using the ESC Link function

(Preparation)

-Connect the T4PK and ESC in accordance with the connection diagram shown on page 104.

-Connect the battery to ESC.

1 Set the transmitter power switch to the display side (DISP ON). Use the (JOG) button and (+) button to display the "ESC-LINK" menu. Set the FET amp power switch to the ON position.

2 (ESC read)

Execute this function to read the connected ESC type and the data currently set at the amp. To save the ESC data to the T4PK, rewrite the read data.

When you want to write the data saved in the T4PK to an ESC of the same type, execute the following "WRITE(TX→MC)"(write) without executing "READ(MC→TX)"(read).

a -Select the setting item "MODE" by (JOG) button up or down operation, and select "READ(MC→TX)" by (+) or (-) button.

b -Select the setting item "EXEC" by (JOG) button up or down operation, and press the (+) and (-) buttons simultaneously for 1 second or longer.

- "COMPLETE!" blinks on the screen and the ESC type and currently set contents are read.

- If "LINK ERROR!" blinks on the screen, communication with the amp is not being performed normally. Check the T4PK and ESC connection and the battery connection to ESC and the ESC power switch and repeat steps a→b.

3 (Writing to ESC)

Execute this function to write the setting data to ESC. See pages 106~107 for the setting data contents.

a -Select the setting item "MODE" by (JOG) button up or down operation, and select "WRITE(TX→MC)" by (+) or (-) button.

b -Select the setting item "EXEC" by (JOG) button up or down operation, and press the (+) and (-) buttons simultaneously for 1 second or longer.

- "COMPLETE!" blinks on the screen and the setting data is written to ESC.

If "LINK ERROR!" blinks on the screen, communication with the amp is not being performed normally. Check the T4PK and ESC connection and the battery connection to ESC and the ESC power switch and repeat steps a→b. In addition, if (NO DATA) is displayed on the T4PK screen, "WRITE(TX→MC)" cannot be selected because there is no setting data to be written.

- Different type ESC data cannot be written. If writing is attempted, "TYPE ERROR!" will link on the screen to show that the ESC type is wrong.

When "MC-LINK" menu is selected when the transmitter power switch is at the transmit side (POWER ON) the message shown below prompting you to set the switch to the display side is displayed.

```
MC LINK 6.3v
PLEASE CHANGE TO
DISPLAY MODE
```

```
MC LINK 6.4v
MODE: READ (MC→TX)
EXEC: PUSH +/- KEY
(NO DATA)
```

```
MC LINK (481CR) 6.4v
MODE: READ (MC→TX)
EXEC: COMPLETE!
IIn:3000|DBA: 15|CLN:300|BND:100
IRX:2500|LBP:3.0|CTH:300|RND: 50
nTB: 0|CLT: 0|FNB: 28
```

```
MC LINK 6.3v
MODE: READ (MC→TX)
EXEC: LINK ERROR!
(NO DATA)
```

```
MC LINK (481CR) 6.4v
MODE: WRITE (TX→MC)
EXEC: COMPLETE!
IIn:3000|DBA: 15|CLN:300|BND:100
IRX:2500|LBP:3.0|CTH:300|RND: 50
nTB: 0|CLT: 0|FNB: 28
```

```
MC LINK (481CR) 6.4v
MODE: WRITE (TX→MC)
EXEC: LINK ERROR!
```

```
MC LINK (481CR) 6.4v
MODE: WRITE (TX→MC)
EXEC: TYPE ERROR!
```

Function

4 (Initialization)

Write the factory set ESC setting data to the connected ESC and T4PK.

a -Select the setting item "MODE" by (JOG) button up or down operation, and select "DEFAULT(MC&TX)" by (+) or (-) button.

b -Select the setting item "EXEC" by (JOG) button up or down operation, and press the (+) and (-) buttons simultaneously for 1 second or longer.

- "COMPLETE!" blinks on the screen, and the initial data is written to ESC. If "LINK ERROR" blinks on the screen, communication with the amp is not being performed normally. Check the T4PK and ESC connection and the battery connection to ESC and the ESC power switch, and repeat steps a→b. In addition, if (NO DATA) is displayed on the T4PK screen, "DEFAULT(MC&TX)" cannot be selected because there is no initial data to be written.

```

7U LINK (481CR) 6.4v
MODE: DEFAULT(MC&TX)
EXEC> COMPLETE!
IIn:3000|D&R: 15|CLM:300|&ND:100
IRX:2500|L&P:3.0|CTH:300|&ND: 50
|nTB: 0|CLT: 0|F&B: 28
    
```

```

7U LINK (481CR) 6.4v
MODE: DEFAULT(MC&TX)
EXEC> LINK ERROR!
IIn:3000|D&R: 15|CLM:300|&ND:100
IRX:2500|L&P:3.0|CTH:300|&ND: 50
|nTB: 0|CLT: 0|F&B: 28
    
```

```

7U LINK (481CR) 6.4v
MODE: DEFAULT(MC&TX)
EXEC> TYPE ERROR!
IIn:3000|D&R: 15|CLM:300|&ND:100
IRX:2500|L&P:3.0|CTH:300|&ND: 50
|nTB: 0|CLT: 0|F&B: 28
    
```

System function setup

1 (Select the setting item by (JOG) button up, down, left, or right operation. Set the value by (+) and (-) button.

```

7U LINK (481CR) 6.4v
MODE: READ (MC&TX)
EXEC: PUSH +/- KEY
CURRENT LIMIT =A
IIn:3000|D&R: 15|CLM:300|&ND:100
IRX:2500|L&P:3.0|CTH:300|&ND: 50
|nTB: 0|CLT: 0|F&B: 28
    
```

The currently set item is displayed here.

Setup item selection

- Select by (JOG) button up, down, left or right operation.

Adjustment buttons

- Use the (+) and (-) buttons to make adjustments.
- Return to the initial value by pressing the (+) and (-) buttons simultaneously (approx. 1 sec).

Setup item

Min-(PWM FREQ MIN LD) 100Hz~10000Hz (10kHz)

Same as Link software PWM frequency (at Min. load), Min sets the "0"A PWM frequency at minimum load.

MAX-(PWM FREQ MAX LD) 100Hz~10000Hz (10kHz)

Same as Link software PWM frequency (at Max. load). MAX sets the PWM frequency at maximum load at the output current limit value set by Current Limiter.

CLM-(CURRENT LIMIT) 50A~300A, OFF

Same as Link software Current Limiter. Current Limiter sets the current value at maximum load here.

Since setting of the MAX is based on the output current limit value set by Current Limiter, Current Limiter does not have to be turned OFF except when a current exceeding 300A is generated.

```

7U LINK (481CR) 6.4v
MODE: READ (MC&TX)
EXEC: PUSH +/- KEY
CURRENT LIMIT =A
IIn:3000|D&R: 15|CLM:300|&ND:100
IRX:2500|L&P:3.0|CTH:300|&ND: 50
|nTB: 0|CLT: 0|F&B: 28
    
```

"Min" which sets the frequency when the load is small, is set to the high frequency side (large value) when extension is desired after straightaways and curves.

"MAX" which sets the frequency when the load is large, is set to the high frequency side (large value) when you want to suppress the rise from low speed and when motor heating and commutator roughness are sensed.

When the rise from low speed is poor, and becomes bad even when "MAX" is set to the low frequency side, use the log data to check if there was a momentary voltage drop.

When you want to suppress the overall power, lengthen the run time, and otherwise improve efficiency, set both "MAX" and "Min" to the high frequency side.

When you want to set a fixed PWM frequency at full range regardless of the load current, set PWM frequency (at Max. load) and PWM frequency (at Min. load) to the same value.

LBP-(LOW BATTERY VOLT) 2.5V~6V

Same as Link software Low Bat Protection
This setting cuts off the output to the motor when the running battery voltage drops to the set voltage to prevent the receiver from stopping operation when the supply of voltage to the receiver becomes insufficient while running due to a drop of the power supply voltage. When the power supply voltage recovers, power is supplied to the motor once more.

```
MC LINK (481CR) 6.4v
MODE: READ (MC→TX)
EXEC: PUSH +/- KEY
CURRENT LIMIT =A
IIn:3000|OER:15|CLM:300|EMD:100
|IRX:2500|LBP:3.0|CTH:300|RMD:50
|nTB:0|CLT:0|FMB:28
```

DBA-(DEAD BAND) ±2µs~±50µs

Same as Link software Dead Band.
This sets the range (neutral point range) over which the ESC does not respond to transmitter throttle operation.
The larger the set value, the wider this range.

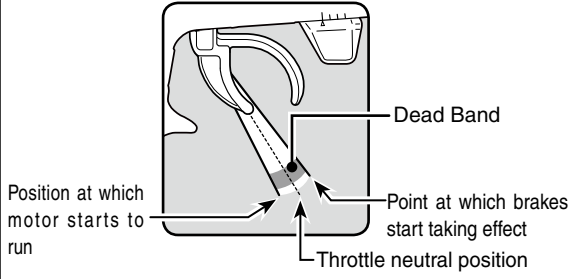

nTB-(NEUTRAL BRAKE) 0%(OFF)-100%

Same as Link software Neutral Brake.
Make this setting when you want to use the brakes at the neutral throttle (OFF) position by throttle operation. The larger this value, the greater the braking force. When you want to use the neutral brake, set this value to "0%".

CTM-(C.L. TIME LIMIT) 50A~300A /CLT-(C.L. TIMER) 0sec(OFF)~240sec

Same as Link software Current Limiter (Time Limit)/Current Limit timer.
The output current can be limited up to the set time lapse from the start of running. This is effective in preventing the motor from outputting wasted energy when the voltage is high immediately after the power battery was recharged.
- "CTM" (Time Limit) sets the maximum output current within the time the output current is limited.
- "CLT" sets the time the output current is limited. This function is disabled when set to "0" sec.
Since the Current Limit Timer starts when the throttle is operated to the forward side and current is output to the motor, this function begins to operate when the motor is run during trim adjustment, etc.

BMD-(BRAKE MAX DUTY) 0%~100%

Same as Link software Brake Max. Duty.
This setting can set the braking force between the neutral point and Max brake point. The larger this value, the greater the braking force. When set to "0%", the brakes are not effective.

RMD-(REVERSE MAX DUTY) MC401CR w/back only 0%~100%

Same as Link software Reverse Max. Duty
This setting can set the reverse power between the neutral point and Max reverse point. The larger this value, the greater the reverse power. When set to "0%", the reverses are not effective.

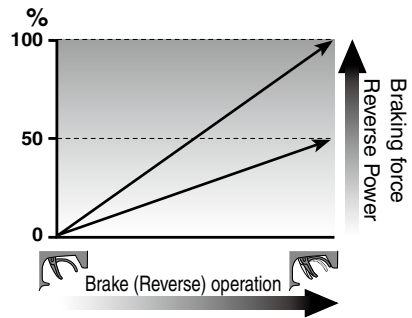

FWB-(FORWARD BOOST) MC401CR/MC601C only

Same as Link software Forward Boost

Operation near the throttle trigger (stick) neutral position becomes a sharp rise.

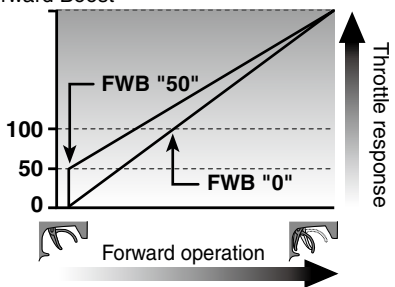

```
MC LINK (481CR) 6.4v
MODE: READ (MC→TX)
EXEC: PUSH +/- KEY
CURRENT LIMIT =A
IIn:3000|OER:15|CLM:300|EMD:100
|IRX:2500|LBP:3.0|CTH:300|RMD:50
|nTB:0|CLT:0|FMB:28
```

Function

System Functions "SYSTEM"

The graphic liquid crystal screen display mode, buzzer sound, LED display mode and initial screen display mode can be set.

The system function setup items cannot be set for each model. (Second condition can be set for each model.)

- Battery type setting (NI-MH 5CELL, DRY 4CELL)

The T4PK can use dry cell batteries (alkaline battery recommended) with the optional battery box, but the low battery alarm setting is different from that of a rechargeable battery. Therefore, always set the battery type matched to the power source used. Especially, when using a Futaba rechargeable type battery, always set the battery type to "NI-MH 5-CELL". If the T4PK is used at "DRY 4-CELL" setting, the time from low battery alarm to stopping of the system will become extremely short.

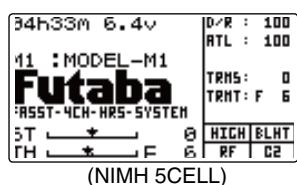

(NIMH 5CELL)

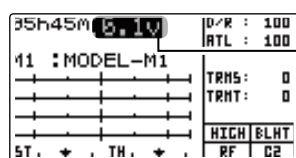

(DRY 4CELL)

* Voltage display
When BATT-TYP is set for dry cell battery (DRY 4CELL), the voltage display of each screen will be displayed by this mark.

- Liquid crystal screen backlighting display mode setup

(OFF, ON at button operation, normally ON)

- Setting of ON time (1~30 secs) when [ON at button operation] was selected above.

- Liquid crystal screen contrast adjustment (20 steps)

- Buzzer sound tone adjustment (OFF, 100 steps)

- LED display color setup (OFF, 7 colors)

- Initial screen display mode setting

("Futaba" display, timer display, servo display, Users name, trim/dial)

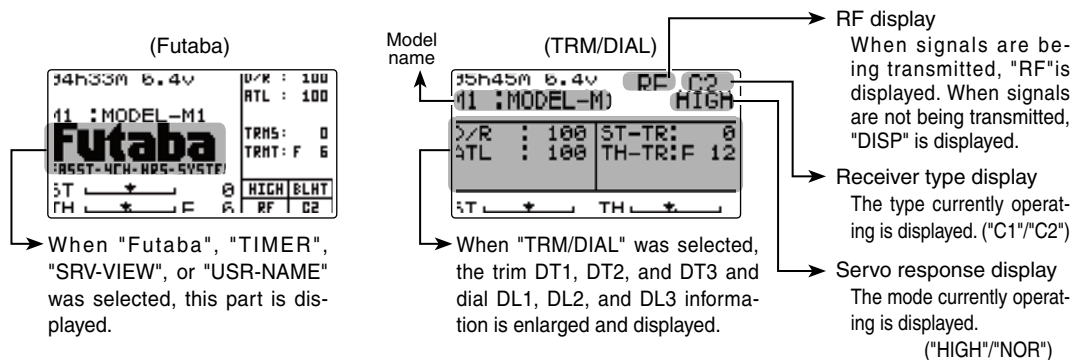

- Second condition setting (INH, ACT)

To use second condition, switch setting by function select switch (page 86) is necessary, in addition to ACT (active) setting by this system.

- The power off forgotten alarm setting (OFF, 10 m)

- 2.4GHz band setting (GENERAL, FRANCE)

Select "GENERAL", except inside France.

Calling the setup screen

*Calling from menu screen (Opening Screen)

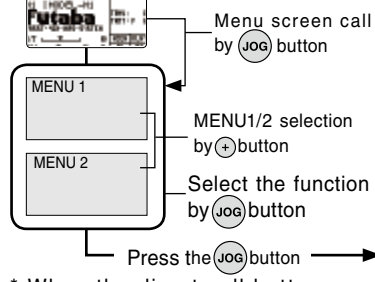

* When the direct call button is set, the setup screen is also called by the following method:

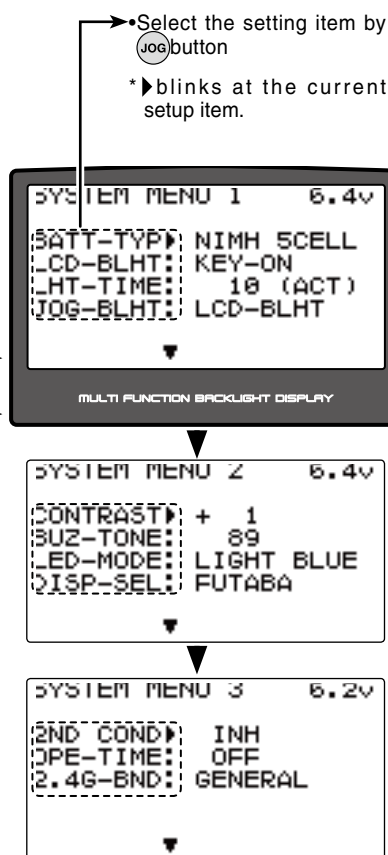
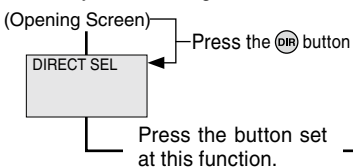

Setup items

- BATT-TYP :Battery type
- LCD-MODE :Backlighting mode
- LHT-TIME :Backlighting time
- JOG-BLHT :Jog button LED mode
- CONTRAST :Contrast
- BUZ-TONE :Buzzer tone
- LED-MODE :LED color
- DISP-SEL :Initial screen mode
- 2ND-COND :2nd condition function
- OPE-TIME :Power off forgotten alarm
- 2.4G-BND :2.4GHz band mode

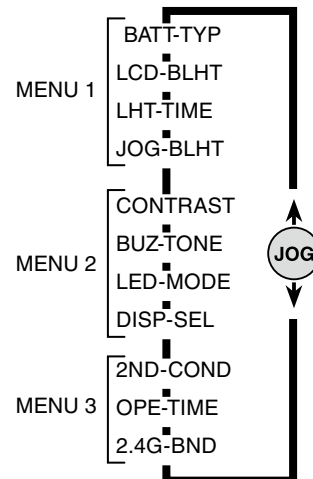

Setting item selection

The items move in the order shown in the figure above.

Adjustment buttons

- Use the (+) and (-) buttons to make adjustments.
- Press the (+) and (-) buttons simultaneously (approx. 1 sec) to return to the initial screen.

Battery Type (BATT-TYP)

NIMH 5CELL, DRY 4CELL

Backlight mode (LCD-BLHT)

KEY-ON, ALWAYS, OFF

Backlighting time (LHT-TIME)

1~30
Initial value: 10

Jog button LED mode (JOG-BLHT)

LCD-BLHT, OFF

System function setup

1 (Setting the battery type)

Select the setting item "BATT-TYP" by (JOG) button up or down operation, and select the mode by pressing the (+) or (-) button.

"NIMH 5CELL":Futaba 5-cells rechargeable battery

"DRY 4CELL" :Dry cell battery (alkaline battery recommended) 4 batteries

(Setting the liquid crystal backlighting mode)

Select the setting item "LCD-BLHT" by (JOG) button up or down operation, and select the mode by pressing the (+) or (-) button.

"KEY-ON" :Fixed time backlighting ON after button operated.

"ALWAYS" :Backlighting always ON

"OFF" :Backlighting OFF

(Setting liquid crystal backlighting time)

Select the setting item "LHT-TIME" by (JOG) button up or down operation, and use the (+) and (-) buttons to set the ON time.

- When "KEY-ON" is set at the preceding item, this ON time becomes effective.

(Jog button LED mode)

Select the setting item "JOG-BLHT" by (JOG) button up or down operation, and use the (+) and (-) buttons to set the ON time.

- When "KEY-ON" is set at the preceding item, this ON time becomes effective.

"LCD-BLHT" :Link to LCD screen backlight setting

"OFF" :Backlighting OFF

(Adjusting the liquid crystal contrast)

Select the setting item "CONTRAST" by (JOG) button up or down operation, and use the (+) and (-) buttons to adjust the screen contrast.

- Adjust to an easy-to-see contrast.

(Adjusting the buzzer tone)

Select the setting item "BUZ-TONE" by (JOG) button up or down operation, and use the (+) and (-) buttons to adjust the tone.

- Decide by referring to the tone at adjustment.

(Changing the LED display color)

Select the setting item "LED-MODE" by (JOG) button up or down operation, and use the (+) and (-) buttons to select the color.

- Select your favorite color while viewing the LED color.

(Changing the initial screen display mode)

Select the setting item "DISP-SEL" by (JOG) button up or down operation, and use the (+) and (-) buttons to select the display mode.

- "Futaba" : "Futaba" logo is displayed on the initial screen.
- "TIMER" : Timer screen is displayed on the initial screen.
- "SRV-VIEW" : Servo operation graph is displayed on the initial screen.
- "USR-NAME" : User name
- "TRM/DIAL" : The trim and dial information is enlarged and displayed on the initial screen.

(Setting the 2nd condition function)

Select the setting item "2ND-COND" by (JOG) button up or down operation, and use the (+) and (-) buttons to select the display mode.

- "ACT" : 2ND Condition ON
- "INH" : 2ND Condition OFF

(Changing the power off forgotten alarm setting)

Select the setting item "OPE-TIME" by (JOG) button up or down operation, and use the (+) and (-) buttons to select the power off forgotten alarm mode.

- "10m" : If an operation is not performed within 10 minutes while the power is on, an audible alarm sounds.
- "OFF" : Power off forgotten alarm setting OFF

(Changing the 2.4GHz band mode)

Select the setting item "2.4G-BND" by (JOG) button up or down operation, and use the (+) and (-) buttons to select the power off forgotten alarm mode.

- "GENERAL" : Always use it
- "FRANCE" : Using this system in France

Contrast (CONTRAST)

-10~0~+10
Initial value: 0

Buzzer tone (BUZ-TONE)

OFF, 1~75~100
Initial value: 85

LED color (LED-MODE)

(OFF), RED, GREEN, YELLOW, BLUE, PURPLE, LIGHT BLUE, WHITE
Initialization : LIGHT BLUE

Initial screen mode (DISP-MODE)

Futaba, TIMER, SRV-VIEW, USR-NAME, TRM/DIAL

2nd condition (2ND-COND)

ACT, INH

The power off forgotten alarm

(OPE-TIME)
10m, OFF

2.4GHz band (2.4G-BND)

GENERAL, FRANCE

- 2 When ending setting, return to the initial screen by pressing the (END) button twice (for function menu screen, press the (END) button once).

About second condition function (2ND COND)

Two kinds of data can be set in one model for specific functions only. For example, two kinds of data such as steering D/R set to 90% at normal condition and steering D/R set to 80% at second condition. This second condition can be set for each model.

- To use the second condition function, setting "2ND-COND" to ACT (active) by "SYSTEM" and switch setting by function select switch (page 86) are necessary.
- Switching from normal condition to second condition by switch set by function select switch is indicated by an audible alarm.
- When switched to the second condition side, the LED blinks (does not blink when "LED-MODE" setting by "SYSTEM" is OFF), and **CD2** is displayed on the initial screen and menu screen and the screen of the functions for which second condition can be set. When switched from second condition to normal condition, an audible alarm sounds and the **CD2** display disappears.

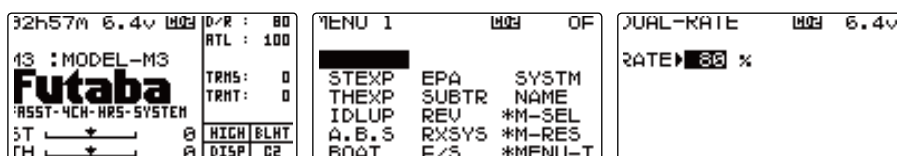

- After "2ND-COND" was set to ACT (active) by "SYSTEM" and switch setting was performed by function select switch (page 86), all the normal condition data is copied to second condition only when initially switched from normal condition to second condition by switch. Thereafter, normal condition and second condition can each set two kinds of data. The items which can be set by second condition are reverse displayed.

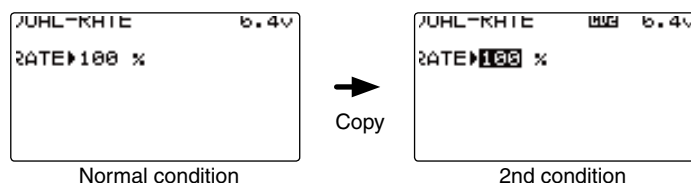

- Each data set by second condition is memorized until "2ND-COND" is changed to the INH (inhibit) state by "SYSTEM", or the data is reset by model setting (page 102). The data is memorized even if switch setting by function select switch is performed.

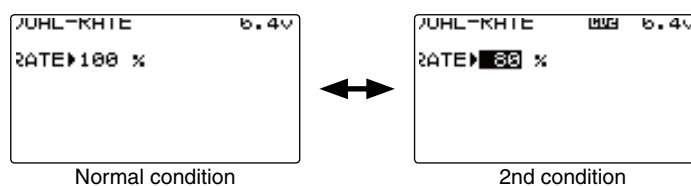

Related function	
Abbreviation used on menu screen	Function name, etc
D/R	Dual rate function
ATL	ATL function
STEXP	Steering EXP
THEXP	Throttle EXP (Forward side) EXP & VTR (not CRV)
STSPD	Steering speed TURN & RETURN side
THSPD	Throttle speed SPEED-LOW, MID, HIGH
A.B.S	2CH A.B.S. function ABS-ABP, ABS-DLY, ABSCYCLE
BRAKE	Brake mixing (3CH,4CH) BRK-RATE, ABS-ABP, ABS-DLY
PMIX1	Program mixing 1 RGHT/BRAK/DOWN sides, LEFT/FWRD/UP sides
PMIX2	Program mixing 2 RGHT/BRAK/DOWN sides, LEFT/FWRD/UP sides

Data Transfer "DTRN"

This function copies the T4PK model memory data to another T4PK. Connect the communication port of both T4PK with the optional DSC cord. Use with this function with the T4PK power switch at the display side.

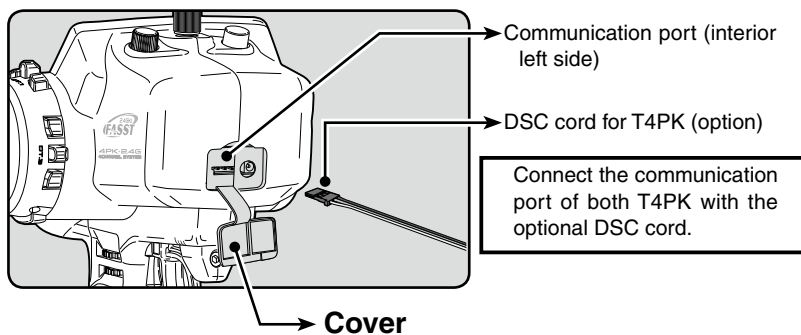

Calling the setup screen

*Calling from menu screen (Opening Screen)

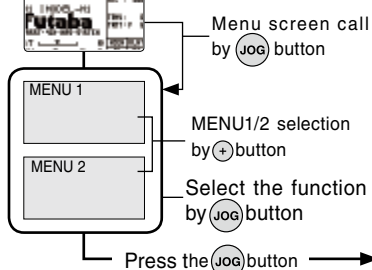

* When the direct call button is set, the setup screen is also called by the following method:

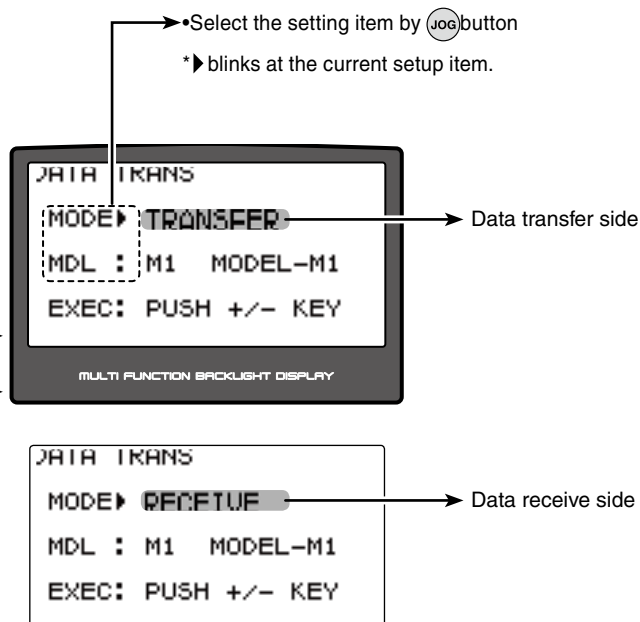
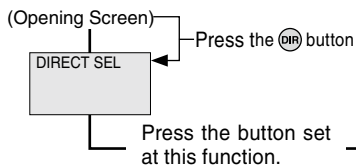

Function

Using the Data Transfer function

(Preparation)

- Connect the communication port of both T4PK with the optional DSC cord.

- 1 Set the power switch of both T4PK to the display (DISP ON) side.
Use the (JOG) button and (+) button to display the "DT-TRN" at both T4PK.

When the "DT-TRN" menu is selected when the transmitter power switch is at the transmit (PWR ON) side, the message shown below prompting you to set the switch to the display side is displayed.

DATA TRANS

PLEASE CHANGE TO
DISPLAY MODE

2 (Select the setting item)

"MODE" by (JOG) button up or down operation, and select the transfer side and receive side by (+) or (-) button.

"TRANSFER" :Data transfer side
"RECEIVE" :Data receive side

```
DATA TRANS
MODE▶ TRANSFER
MDL : M1 MODEL-M1
EXEC: PUSH +/- KEY
```

Setup item selection

- Select by (JOG) button up or down operation.

Mode change button

- Use the (+) and (-) buttons to make adjustments.

Mode selection

"TRANSFER" "RECEIVE"

3 (Model memory selection)

Select the setting item "MDL" by (JOG) button up or down operation of both T4PK, and select the transfer model number and receive side model number by (+) or (-) button.

```
DATA TRANS      DATA TRANS
MODE: TRANSFER  MODE: RECEIVE
MDL ▶ M1 MODEL-M1 MDL ▶ M1 MODEL-M1
EXEC: PUSH +/- KEY EXEC: PUSH +/- KEY
```

Model number selection

- Use the (+) and (-) buttons to make adjustments.

Model# and model name of data sending and receive side.

4 (Data transfer execution)

Select the setting item "EXEC" by (JOG) button up or down operation of both T4PK.

First, press the receive side "RECEIVE" T4PK (+) and (-) buttons simultaneously. The message "WAITING! 30S" appears and count down begins.

Within 30 seconds, press the transfer side "TRANSFER" T4PK (+) and (-) buttons simultaneously. (If data transfer is not executed within 30 seconds, an error will be displayed at the receive side "RECEIVE" T4PK.)

- "COMPLETE!" is displayed on the screen of the receive side "RECEIVE" T4PK and data transfer is ended.

```
DATA TRANS      DATA TRANS
MODE: TRANSFER  MODE: RECEIVE
MDL : M1 MODEL-M1 MDL : M1 MODEL-M1
EXEC▶ COMPLETE! EXEC▶ COMPLETE!
```

Transfer execution button

- (+) and (-) buttons pressed simultaneously for about 1 second.

30 seconds wait is displayed on the receive side screen.

-If "RCV ERROR!" is displayed on the screen of the receive side "RECEIVE" T4PK, data transfer was not performed normally. Check the connection and repeat steps 1→4. Since the transfer side "TRANSFER" T4PK only sends, "COMPLETE!" is displayed even when data transfer was not performed normally.

```
DATA TRANS
MODE: RECEIVE
MDL : M1 MODEL-M1
EXEC▶ RCV ERROR !
```

Error

Adjuster "ADJST"

Steering and throttle correction can be applied. Use this function when a mechanical off-set has occurred for some reason.

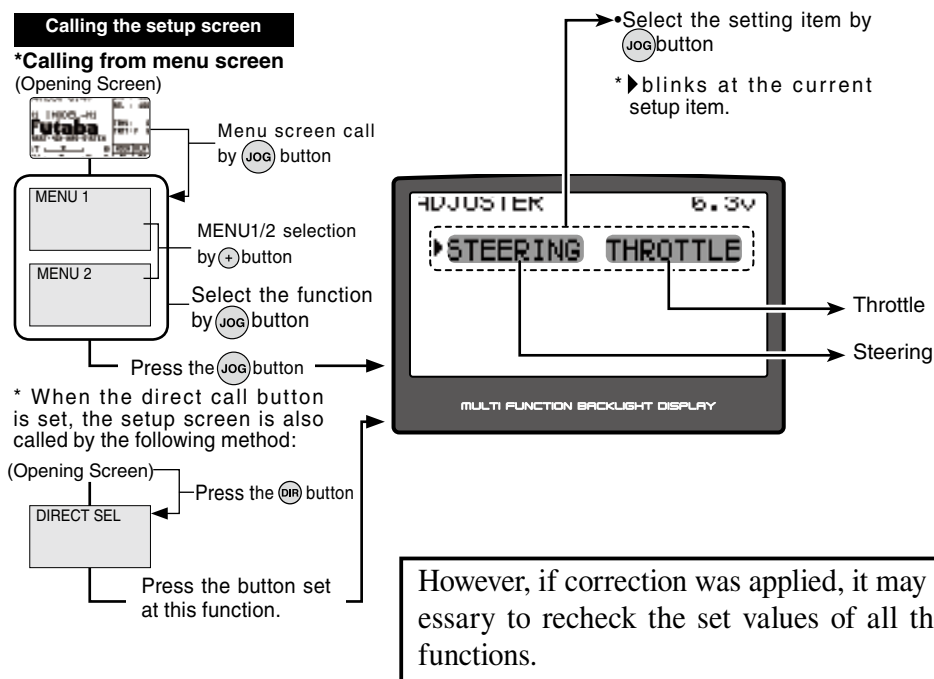

Steering adjustment

(Preparation)

In the steering side selected state, select the adjustment screen by pressing the (JOG) button.

1 (Steering neutral adjustment)

In the neutral setup screen (figure at the right) state, lightly pull the steering wheel and then press the (JOG) button in the state in which the wheel is not being touched.

2 (Steering throw adjustment)

In the throw setup screen (figure at the right) state, lightly turn the wheel fully to the left and right and press the (JOG) button.

3 (Correction execution)

At the check screen, and press the (+) and (-) buttons simultaneously.

```
ADJUSTER 6.3V
STEERING
>NEUTRAL ( 5%)
```

```
ADJUSTER 6.3V
STEERING
NEUTRAL ( 5%)
>RIGHT (107%)
>LEFT ( 91%)
```

```
ADJUSTER 6.3V
STEERING
NEUTRAL ( 5%)
RIGHT (107%)
LEFT ( 90%)
>EXECUTE? >PUSH +/-
(CANCEL >PUSH END)
```

Internal checks are performed automatically and when each adjustment point is in a fixed range, correction is performed and "SUCCESSFUL!" (figure at the right) is displayed.

If an adjustment point is not within a fixed range, an error is displayed (figure at the right) and the correction data is not updated.

- 4 When ending setting, return to the initial screen by pressing the (END) button twice (for function menu screen, press the (END) button once).

```

ADJUSTER          6.3v
STEERING

NEUTRAL ( 5%) OK
RIGHT  (107%) OK
LEFT   ( 98%) OK

SUCCESSFUL!
  
```

```

ADJUSTER          6.3v
STEERING

NEUTRAL ( 5%) OK
RIGHT  ( 36%) ERR
LEFT   ( 98%) OK

FAIL! (NOT CHANGED)
  
```

Throttle adjustment

(Preparation)

In the state in which the throttle side is selected, select the adjustment screen by pressing the (SEL) button.

- 1 (Throttle neutral adjustment)

In the neutral setup screen (figure at the right) state, lightly pull the throttle trigger and then press the (JOG) button in the state in which the trigger is not being touched.

- 2 (Throttle throw adjustment)

In the throw setup screen (figure at the right) state, lightly operate the trigger fully to the brake side and forward side and press the (JOG) button.

- 3 (Correction execution)

At the check screen (figure at the right), and press the (+) and (-) buttons simultaneously. Internal checks are performed automatically, and when each adjustment point is within a fixed range, correction is performed and "SUCCESSFUL!" (figure at the right) is displayed.

If an adjustment point is not within a fixed range, an error is displayed (figure at the right) and the correction data are not updated.

- 4 When ending setting, return to the initial screen by pressing the (END) button twice (for function menu screen, press the (END) button once).

```

ADJUSTER          6.3v
THROTTLE

▶NEUTRAL ( 19%)
  
```

```

ADJUSTER

▶FORWARD (108%)
▶BRAKE   (106)
  
```

```

ADJUSTER          6.3v
THROTTLE

NEUTRAL ( 19%) OK
FORWARD (108%) OK
BRAKE   (107%) OK
▶EXECUTE? >PUSH +/-
(CANCEL >PUSH END)
  
```

```

ADJUSTER          6.3v
THROTTLE

NEUTRAL ( 19%) OK
FORWARD (108%) OK
BRAKE   (106%) OK

SUCCESSFUL!
  
```

```

ADJUSTER          6.3v
THROTTLE

NEUTRAL ( 19%) OK
FORWARD (108%) OK
BRAKE   ( 27%) ERR

FAIL! (NOT CHANGED)
  
```

Function

Vibrator Function "VIBRA"

The vibrator built into the grip can be activated at lap navigation navigate alarm, each racing timer time up, powering ON, push sw on/off and low battery alarm.

The vibrator operation pattern can be selected from among 7 types

Setup items

TIMER TIME-UP	:Timer time up
LAP-NAVI	:Navigation alarm
FUEL RES-START	:Fuel timer restart
PUSH SW ON	:At push sw on
PUSH SW OFF	:At push sw off
POWER-ON	:At power on
LOW-BATT ALRM	:Low battery

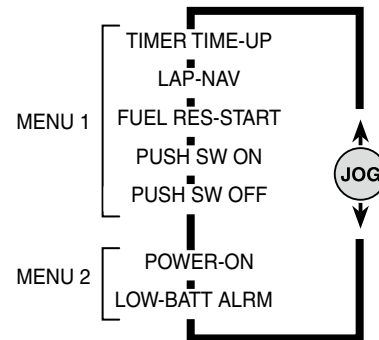

Calling the setup screen

***Calling from menu screen**
(Opening Screen)

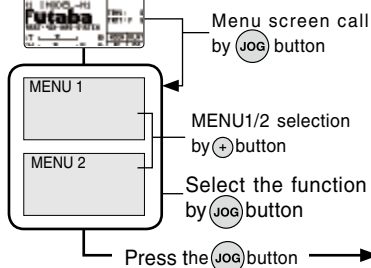

* When the direct call button is set, the setup screen is also called by the following method:

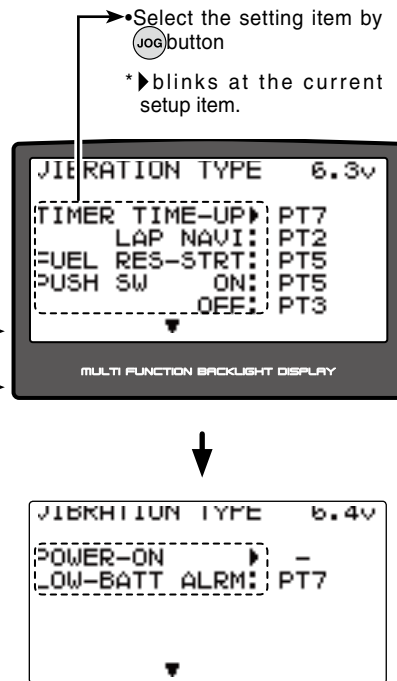
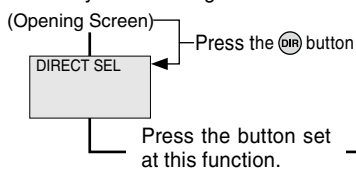

Setting item selection

The items move in the order shown in the figure above.

Setup item selection

- Select by (JOG) button up or down operation.

Adjustment buttons

- Use the (+) and (-) buttons to make adjustments.
- Press the (+) and (-) buttons simultaneously (approx. 1 sec) to return to the initial screen.

Timer time up (TIME-UP)

OFF, TYPE-1~TYPE-7
Initialization :TYPE-2

Navigation alarm (LAP-NAVI)

OFF, TYPE-1~TYPE-7
Initialization :TYPE-2

Fuel timer restart

(FUEL RES-START)
OFF, TYPE-1~TYPE-7
Initialization :TYPE-5

At push sw on (PUSH SW ON)

OFF, TYPE-1~TYPE-7
Initialization :TYPE-5

At push sw off (PUSH SW OFF)

OFF, TYPE-1~TYPE-7
Initialization :TYPE-4

At power on (POWER-ON)

OFF, TYPE-1~TYPE-7
Initialization :OFF

Low battery (LOW-BATT)

OFF, TYPE-1~TYPE-7
Initialization :TYPE-7

Function

Vibrator setup

1 (Setting vibrator)

Select the setting item by (JOG) button up or down operation and select the type by pressing the (+) or (-) button.

2 When ending setting, return to the initial screen by pressing the (END) button twice (for function menu screen, press the (END) button once).

Steering Dual Rate/Second Dual Rate "D/R"(Steering system)

The steering left and right servo travels are adjusted simultaneously. When you want to increase the servo travel, adjust the + side. When you want to decrease the servo travel, adjust the - side. This setting is linked to transmitter grip dial DL1. When DL1 is assigned another function, dual rate can be adjusted with this screen.

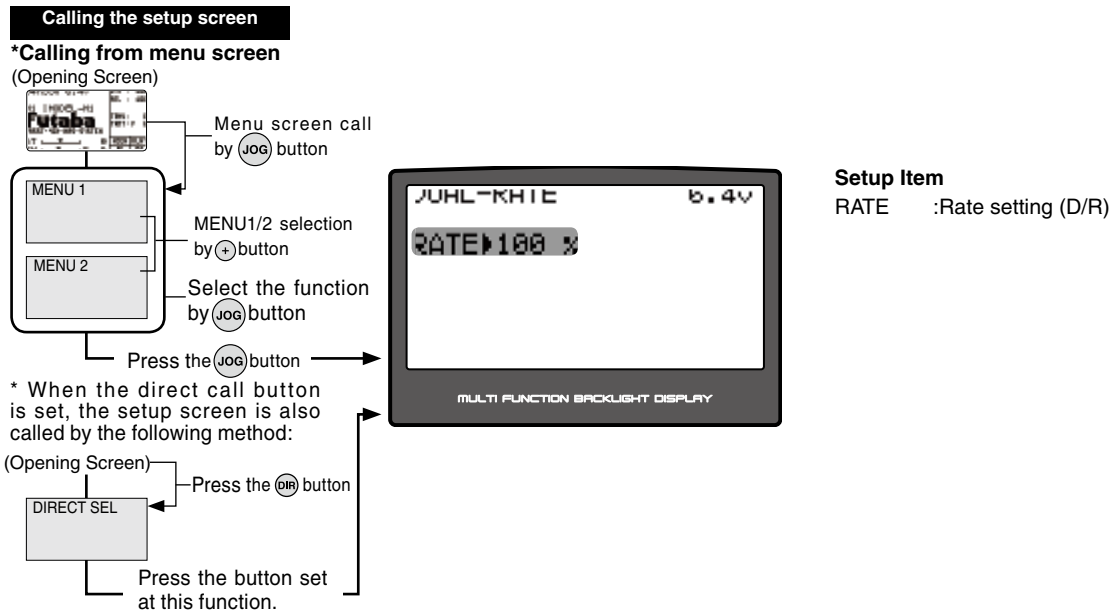

Dual rate adjustment

1 (Dual rate adjustment)

Select the setting item "RATE" by (JOG) button up or down operation. Adjust the servo travel with the (+) and (-) buttons.

This dual rate servo travel is linked to the grip dial.

2 When ending setting, return to the initial screen by pressing the (END) button twice (for function menu screen, press the (END) button once).

Setup item selection

- Select by (JOG) button up or down operation.

Adjustment buttons

- Use the (+) and (-) buttons to make adjustments.
- Press the (+) and (-) buttons simultaneously (approx. 1 sec) to return to the initial screen.

D/R rate (RATE)

0~100%
Initial value: 100

Function

Throttle ATL Function "ATL"

(Throttle system)

This function decreases the set value when the braking effect is strong and increases the set value when the braking effect is weak.

This function is linked to transmitter grip dial DL2. When DL2 is assigned another function, this function can be set with this screen.

Operation

The throttle brake side (when the throttle is pushed forward) brake amount can be adjusted.

Calling the setup screen

*Calling from menu screen
(Opening Screen)

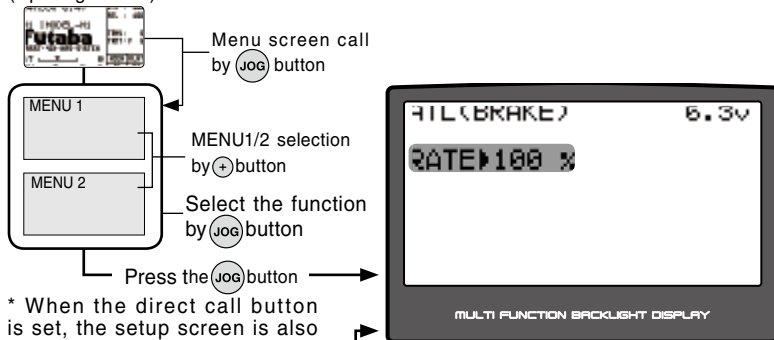

Setup Item

RATE :Brake amount

* When the direct call button is set, the setup screen is also called by the following method:

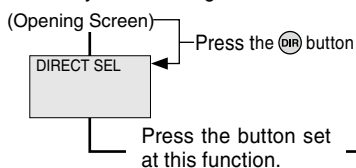

Function

ATL function adjustment

1 (Brake amount adjustment)

Use the (+) and (-) buttons to adjust the brake amount.

Adjust the - side when the braking effect is strong and the + side when the braking effect is weak.

2 When ending setting, return to the initial screen by pressing the (END) button twice (for function menu screen, press the (END) button once).

Adjustment buttons

- Use the (+) and (-) buttons to make adjustments.
- Press the (+) and (-) buttons simultaneously (approx. 1 sec) to return to the initial screen

Brake amount (RATE)

0~100%
Initial value: 100%

Channel 3/4 position "CH3", "CH4" (3rd or 4th channel system)

The channel 3/4 servo position can be set from the transmitter. When CH3 is assigned to a dial by the dial function (p.88), this setting is linked to that dial.

When CH3/4 is not assigned to a dial, it can be set with this screen.

When CH3/4 is assigned to a switch by the switch function (p.86), you cannot adjust the CH3/4 via the screen.

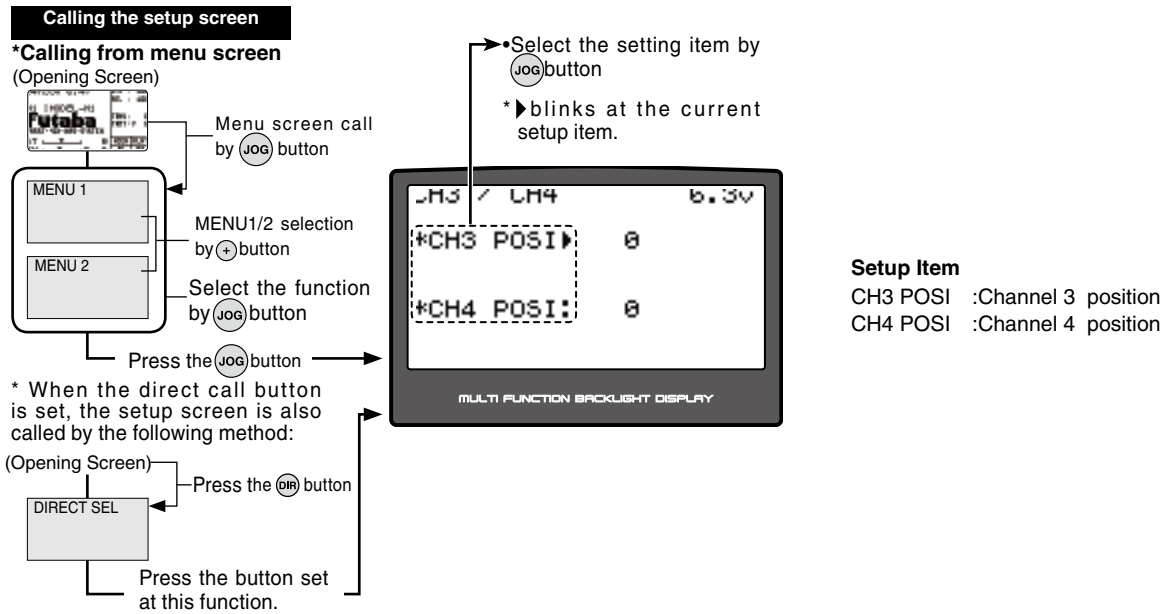

Channel 3/4 adjustment

1 (Position adjustment)

Use the (+) and (-) buttons to adjust the channel 3 or channel 4 position.

2 When ending setting, return to the initial screen by pressing the (END) button twice (for function menu screen, press the (END) button once).

Adjustment buttons

- Use the (+) and (-) buttons to make adjustments.
- Press the (+) and (-) buttons simultaneously (approx. 1 sec) to return to the initial screen

Channel 3 position (POSI)

Channel 4 position (POSI)

0~100%
Initial value: 100%

Function

Servo View "SERVO"

Servo operation of each channel can be checked. Operation of the steering angle adjustment, when a mixing function was set, etc. can be easily checked. The servo view can also be displayed on the initial screen by using the system function (See page 108).

The neutral position of the throttle channel varies depending on the modes defined by the "THR-MODE". The screen shown below shows an example of "F50/B50" in the "NORMAL" mode.

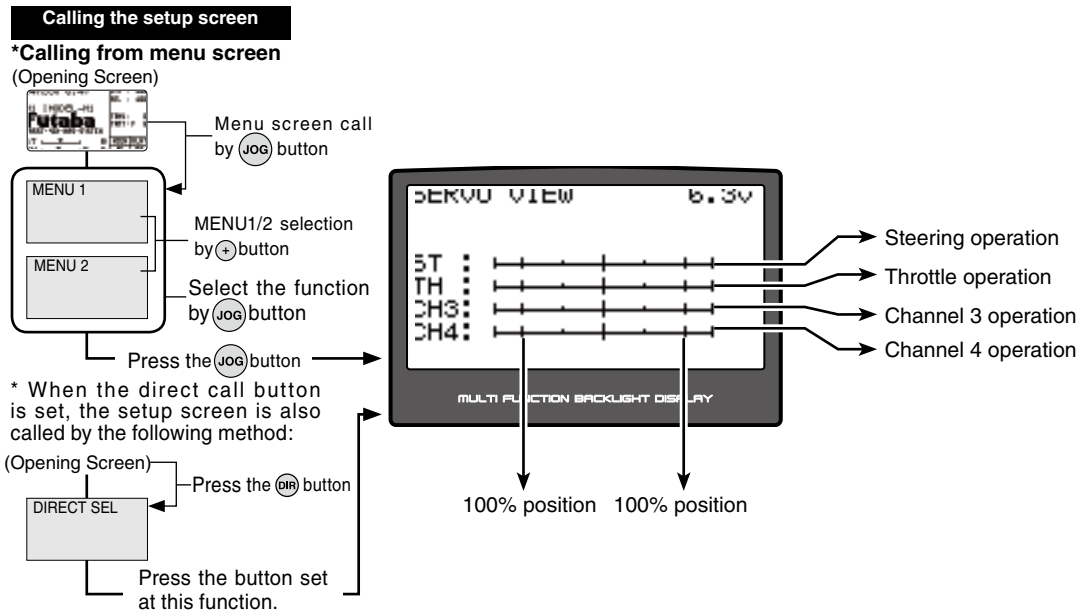

Ending the "SERVO" screen

- 1 When ending servo operation checks, return to the initial screen by pressing the (END) button twice (for function menu screen, press the (END) button once).



Reference

Ratings

*Specifications and ratings are subject to change without prior notice.

Transmitter T4PK

(Wheel system, 4 channels)

- Transmitting frequencies 2.4GHz band
- Futaba FASST-C2(R604FS), FASST-C1(R603FS/FF)
- Power requirement
 - (Ni-MH battery) NT5F1700B Ni-MH battery (6V)
 - (Dry cell battery) Penlight x 4 (6V)
- Current drain 250mA or less (Vibration and back lighting off)
- Transmitting antenna $1/2 \lambda$ dipole

Receiver R604FS

(4 channels receiver)

- Receiving frequencies 2.4GHz band
- Power requirement 6.0V Ni-Cd battery (shared with servos)
- Current drain 95mA
- Size 39x26x14mm (1.54x1.02x0.55in)
- Weight 13.4g (0.47oz)

Caution

- ❗ When using the T4PK in the high speed (HIGH SPEED) mode, always use it under the following conditions:

Servos : 6V Futaba digital servo (including BLS Series brushless servos)
Receiver's Battery : 6V Ni-Cd battery
Transmitter mode : HIGH SPEED mode (See p.46 for setting method.)

Under other conditions, the set will not operate, or the specified performance will not be displayed even if it operates. In addition, it may cause servo trouble. Futaba will not be responsible for damage, etc. caused by combination with the products of other companies.

In addition, the FSU1 Fail Safe Unit cannot be used because the system is different. Use the fail safe function of the transmitter.

- ❗ When using analog servos, always switch the T4PK servo response to the NORMAL mode.

Transmitter mode : NORMAL mode (See p.46 for setting method.)
Receiver's Battery : 6V Ni-Cd battery

The set cannot operate in the HIGH SPEED mode. Operation in this mode will cause trouble of servo and other equipments. Digital servos (including BLS Series brushless servos) can also be used in the NORMAL mode.

Optional Parts

The following parts are available as 4PK options. Purchase them to match your application. For other optional parts, refer to our catalog.

Transmitter Ni-MH Battery

When purchasing a transmitter Ni-MH battery as a spare, etc., use the following:

Part name

NT5F1700B (6V/1700mAh)

Please do not use the transmitter's battery, HT5F1700B, as the receiver's battery.

Since the transmitter's battery has an overload protection circuit, the output power will be shut down when the high current load is applied. This may result in run-a-way or fatal crash.

Battery Holder (Transmitter)

This battery holder is necessary when using the transmitter with a dry cell battery.

For a description of how to install the battery holder to the transmitter, see "Ni-MH Replacement" on page 18.

Part name

T4PK transmitter battery holder

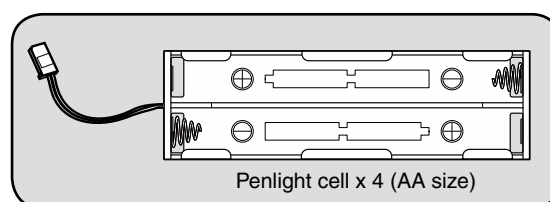

<Check>

Turn on the power switch and check the LCD battery voltage display. When the batteries are new, the voltage should be about 6V.

If the voltage does not rise, check for faulty contacts or incorrect polarity.

<Disposal of the Dry Cell Batteries>

The method to dispose of used dry cell batteries depends on the area in which you reside. Dispose of the batteries in accordance with the regulations for your area.

⚠ Caution

- ⊘ Do not use commercial AA size Ni-cd and Ni-MH batteries.

Quick charging may cause the battery contacts to overheat and damage the battery holder.



Use prohibited



- ⓘ Insert the batteries in the correct polarity.

If the polarity is incorrect, the transmitter may be damaged.

- ⓘ When the transmitter is not in use, remove the batteries.

If the battery electrolyte leaks, wipe off the case and contacts.

DSC cord

When the T4PK transmitter and R604FS or R603FS/FF receiver are connected with the DSC cord, the servos can be operated without emitting radio waves. (DSC function)

Part name



Connection

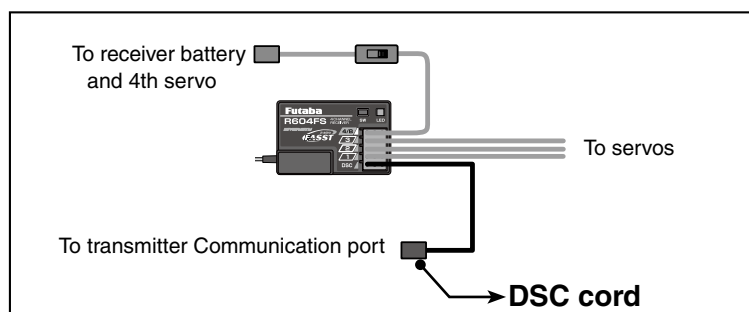
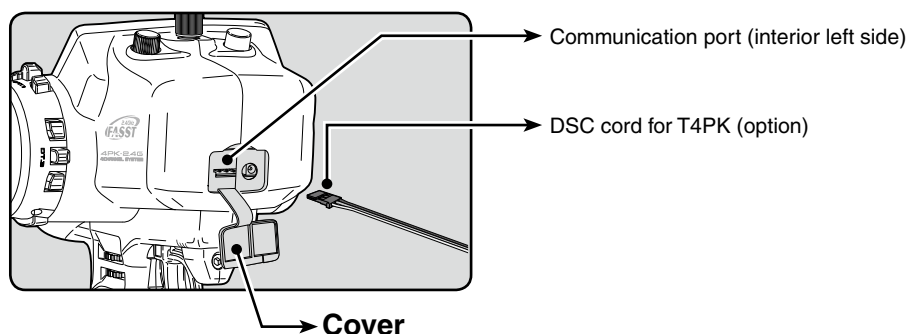

Connect the T4PK and receiver using the DSC cord, after turn off the T4PK and receiver power switches.

Turn on the display switch of the T4PK and then turn on the receiver power. If this sequence is not followed, a malfunction could occur.

You can check the servo operation without emitting radio waves.

After checking the servo operation, disconnect the DSC cord and then cycle power of the receiver before operating the T4PK. If this sequence is not followed, a malfunction could occur.

Warning Displays

Backup Error

If the data is lost for an unknown reason, an audible alarm will sound and "BACK UP ERROR" will be displayed on the LCD screen.

LCD screen:

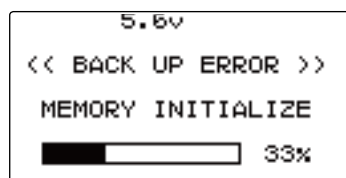

Audible alarm:

Tone will sound (9 times), then repeat.

Warning

❗ When a backup error is generated, immediately stop using the system and request repair from the Futaba Service Center.

If you continue to use the system, the transmitter may malfunction and cause loss of control

Low Battery Alarm

If the transmitter battery voltage drops to 4.9V(when using dry cell battery: 4.1V) or less, an audible alarm will sound and "LOW BATTERY" will be displayed on the LCD screen.

LCD screen:

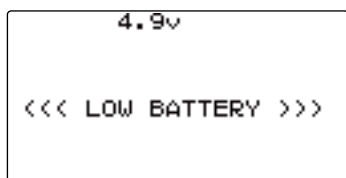

Audible alarm:

Continuous tone.

The vibrator:

Active (initial setting) page 116

Warning

❗ When a low battery alarm is generated, cease operation immediately and retrieve the model.

If the battery goes dead while in operation, you will lose control.

Power supply and low battery alarm

Dry cell batteries (alkaline batteries are recommended) can be used with the optional battery box. However, when using dry cell batteries, set BATT-TYPE in the system menu to DRY 4-CELL. When BATT-TYPE is set to DRY 4-CELL. When using the T4PK standard HT5F1700B battery, always set BATT-TYP to NIMH 5-CELL. (See page 108, for a detailed description of the battery types.)

High voltage alarm

If a battery exceeding 8V is used with the T4PK, an audible alarm will sound and "HIGH VOLTAGE" will be displayed on the LCD screen.

Immediately remove the battery because it may cause the T4PK to malfunction.

LCD screen:

```
8.1v
<< HIGH VOLTAGE >>
```

Audible alarm:

Tone sounds (7 times) and stops (repeated)

Memory Error

If the data in the transmitter is not transferred normally when the power is turned on, an audible alarm will sound and "ACCESS ERROR" will be displayed on the LCD.

- To stop the alarm, turn off the power.
- Turn the power back on. If the alarm is not generated again, there is no problem.

LCD screen:

```
6.8v
MAIN MEMORY
<< ACCESS ERROR >>
```

Audible alarm:

Tone sounds (7 times) and stops (repeated)

MIX Warning

When the power switch is turned on while the idle-up, preset (engine cut) or neutral brake function switch is on, an audible alarm will sound and "MIX WARNING" will be displayed on the LCD. When those function switch is turned off, the alarm will stop.

LCD screen:

```
6.4v
IDLE UP or PRESET
or NEUTRAL BRAKE
<< MIX WARNING >>
```

Audible alarm:

Tone sounds (7 times) and stops (repeated)

Power off forgotten warning

If the T4PK is not operated for 10 minutes, an audible alarm is sounded and "WARNING" is displayed on the screen. The audible alarm stops when the steering wheel, throttle trigger, and any dial, switch, or edit button is operated. If you are not going to use the transmitter, turn the power off. (Setting can be reset at the system menu on page 108.)

LCD screen:

```
6.2v
NOT OPERATED
FOR A LONG TIME
<< WARNING >>
```

Audible alarm:

Tone sounds (7 times) and stops (repeated)

When requesting repair

Before requesting repair, read this instruction again and recheck your system. Should the problems continue, request as follows.

(Information needed for repair)

Describe the problem in as much detail as possible and send the letter along with the system in question.

- Symptom (Including the conditions and when the problem occurred)
- R/C System (Send transmitter, receiver and servos)
- Model (Type of model, brand name and model number or kit name)
- Detailed packing list (Make a list of all items sent in for repair)
- Your name, address and telephone number.

(Warranty)

Read the Warranty card.

- When requesting warranty service, send the card or some type of dated proof purchase.