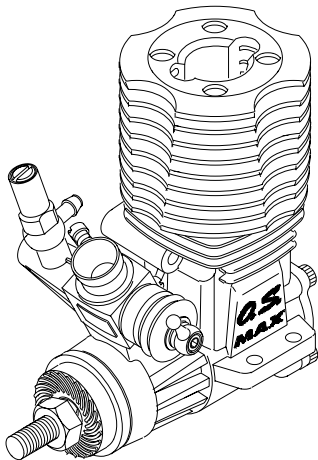

O.S. ENGINE

MAX-15CV-R SERIES

OWNER'S INSTRUCTION MANUAL

It is of vital importance, before attempting to operate your engine, to read the general **'SAFETY INSTRUCTIONS AND WARNINGS'** section on pages 2-5 of this booklet and to strictly adhere to the advice contained therein.

- Also, please study the entire contents of this instruction manual, so as to familiarize yourself with the controls and other features of the engine.
- Keep these instructions in a safe place so that you may readily refer to them whenever necessary.
- It is suggested that any instructions supplied with the vehicle, radio control equipment, etc., are accessible for checking at the same time.



CONTENTS

SAFETY INSTRUCTIONS AND WARNINGS ABOUT YOUR O.S. ENGINE	2~5	IF THE ENGINE FAILS TO START	17
INTRODUCTION, BASIC ENGINE PARTS	6	FINAL ADJUSTMENT	17~18
INSTALLATION	7~8	CARBURETOR CLEANLINESS	19
AIR CLEANER	8~10	CARE AND MAINTENANCE	20
NOTES CONCERNING THE RECOIL STARTER	10~11	O.S. GENUINE PARTS & ACCESSORIES	21
GLOWPLUG	11~12	ENGINES EXPLODED VIEW & PARTS LIST	22~27
TOOLS, ACCESSORIES, etc.	12~13	CARBURETOR EXPLODED VIEW & PARTS LIST	28~29
CARBURETOR CONTROLS	13~14	THREE VIEW DRAWING	30~32
PRESSURIZED FUEL SYSTEM	14		
STARTING THE ENGINE & RUNNING-IN('Breaking-in)	15~16		

SAFETY INSTRUCTIONS AND WARNINGS ABOUT YOUR O.S. ENGINE

Remember that your engine is not a "toy", but a highly efficient internal-combustion machine whose power is capable of harming you, or others, if it is misused.

As owner, you, alone, are responsible for the safe operation of your engine, so act with discretion and care at all times.

If at some future date, your O.S. engine is acquired by another person, we would respectfully request that these instructions are also passed on to its new owner.

- The advice which follows applies basically to **ALL MODEL ENGINES** and is grouped under two headings according to the degree of damage or danger which might arise through misuse or neglect.



WARNINGS

These cover events which might involve serious (in extreme circumstances, even fatal) injury.



NOTES

These cover the many other possibilities, generally less obvious sources of danger, but which, under certain circumstances, may also cause damage or injury.



WARNINGS

- Model engine fuel is poisonous. Do not allow it to come into contact with the eyes or mouth. Always store it in a clearly marked container and out of the reach of children.



- Model engine fuel is also highly flammable. Keep it away from open flame, excessive heat, sources of sparks, or anything else which might ignite it. Do not smoke or allow anyone else to smoke, near to it.



- Never operate your engine in an enclosed space. Model engines, like automobile engines, exhaust deadly carbon-monoxide. Run your engine only in an open area.

- Model engines generate considerable heat. Do not touch any part of your engine until it has cooled. Contact with the muffler (silencer), cylinder head or exhaust header pipe, in particular, may result in a serious burn.





NOTES

- This engine is intended for model cars. Do not attempt to use it for any other purpose.
- Mount the engine in your model securely, following the manufacturers' recommendations, using appropriate screws and locknuts.
- Install an effective silencer (muffler). Frequent close exposure to a noisy exhaust (especially in the case of the more powerful highspeed engines) may eventually impair your hearing and such noise is also likely to cause annoyance to others over a wide area.
- The wearing of safety glasses is also strongly recommended.
- Take care that the glowplug clip or battery leads do not come into contact with rotating parts. Also check that the linkage to the throttle arm is secure.
- For their safety, keep all onlookers (especially small children) well back (at least 20 feet or 6 meters) when preparing your model for running.



NOTES

- To stop the engine, fully retard the throttle stick and trim lever on the trans-mitter, or, in an emergency, cut off the fuel supply by pinching the fuel delivery line from the tank.
- Do not attempt to disassemble the recoil starter of the 15CV-RX. If you do so, the very strong spring inside will be suddenly ejected. This can be very dangerous.
- Do not extend the starter cord more than 45cm (18"). Do not abruptly release the operating handle. Allow the cord to rewind smoothly while still holding the handle.
- Pull the operating handle straight out when starting the engine, so that the cord does not rub against the vehicle body or engine. This will help prevent the cord from being damaged by abrasion or engine heat.
- Warning! Immediately after a glowplug-ignition engine has been run and is still warm, conditions sometimes exist whereby it is just possible for the engine to abruptly restart if it is rotated over compression WITHOUT the glowplug battery being reconnected.

The MAX-15CV-R is high-performance engines for 1/10 class R/C racing cars. There are two versions, the one with 10E-R carburettor and the other with 10C carburetor.

Standard accessories

- Glow Plug No.8
- Super Air Cleaner 102
 - 102 Cleaner Body
 - 101,102 Filter Elements (3pcs.)
- Engine Mount Spacer (For 15CV-RX)

NOTE: With this engine, the piston will feel tight at the top of its stroke when the engine is cold. This is normal. The piston and cylinder are designed to achieve a perfect running clearance when they reach their normal running temperatures.

NOTE

As delivered, the engine has its carburetor lightly fit into its intake. Secure it changing its angle according to the car chassis.

BASIC ENGINE PARTS

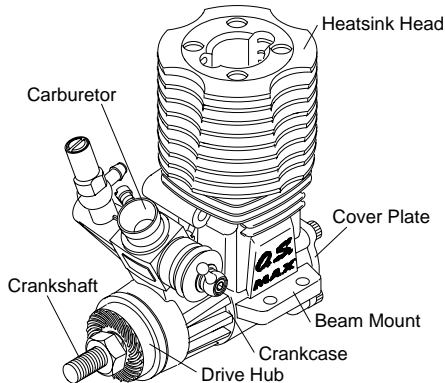

INSTALLING THE GLOWPLUG

Install washer on glowplug and insert carefully into cylinder-head, making sure that it is not cross-threaded before tightening firmly.



INSTALLATION OF THE CARBURETOR

As delivered, the engine has its carburetor lightly install into the intake boss. Secure it as follows.

1. Loosen the retainer screw, rotate the carburetor to its correct position and make sure that it is pressed well down into the intake boss, compressing the rubber gasket, before retightening screw.
2. Rotate the retainer screw gently until it stops, then tighten a further 60-90°. Do not overtighten the screw as this will damage the carburetor body.

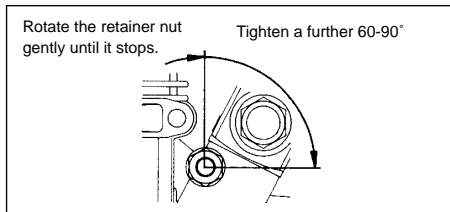

ENGINE INSTALLATION

Make sure that the vehicle's engine mounting surfaces are level and in the same plane. Poor installation may cause distortion of the crankcase, bearings, etc., resulting in erratic running and loss of performance.

The recommended screws for securing the engine are 3mm or 4-40 steel Allen hexagon socket type.

If existing holes in the engine mount do not align perfectly with engine mounting lugs, enlarge them slightly with a needle-file so that screws enter vertically.

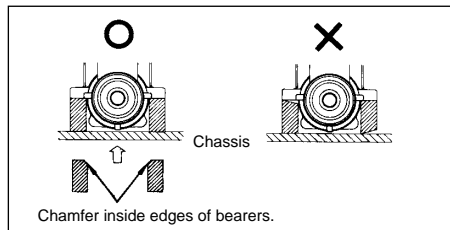

Avoid forcing the screws. Secure with locknuts. If the bottom of the recoil starter housing would otherwise touch the car chassis, fit the engine mount spacers (supplied) between the engine's mounting lugs and the engine mount. Use the M3x15 screws provided. With some vehicles, it may be necessary to make minor trimming modifications to chassis or body when fitting the engine.

NOTE:

Where spacers are supplied joined in pairs (see sketch) separate them as shown.

Either face may be placed downwards.

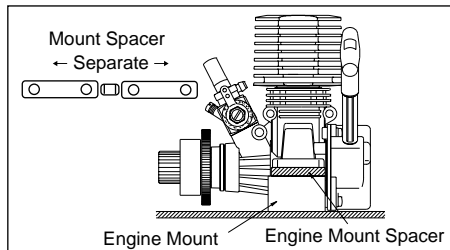

AIR CLEANER TYPE 102

This is a heavy-duty wet type air cleaner that has been developed specifically for the O.S. MAX-CV series model car engines.

It contains specially impregnated filter elements which prevent highly damaging dust and dirt from being drawn into the engine through the carburetor, yet allow engine performance to be maintained for longer periods between element renewals. The Type 102 air cleaner has a special rubber body which facilitates easy yet secure fitting, with positive sealing at the carburetor air intake.

INSTALLATION OF AIR CLEANER

- Carefully clean the carburettor, removing any old adhesive or sealant that may have been previously used on the outside of the air intake.
- Press the air cleaner body firmly over the carburetor air intake. Make sure that the outer rim of the air intake engages the internal annular groove in the air cleaner: failure to do so may result in the air cleaner falling off. See sketch, right.

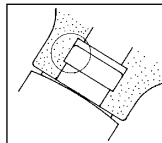

- Position the air cleaner correctly, so that it does not foul the cylinder-head or obstruct the needle-valve.

AIR CLEANER ELEMENTS

- Replacement elements are already impregnated with filter oil. As this oil is very sticky, take care, when handling elements to prevent dust or dirt from adhering them. If your fingers become contaminated, wash them with soap and water.

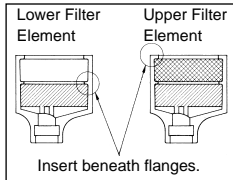

- During storage, the oil may have become unevenly dispersed through the elements. This will be indicated if the blue color of the element material appears patchy. In this case, place the elements in a small plastic bag and gently rub them between finger and thumb to redistribute the oil.

REPLACEMENT OF ELEMENTS

- It is advisable to replace the upper filter element with a new one after not more than one hour of running time. It is not necessary to discard the lower element so frequently, but be sure to change it when it becomes soiled.

Always remove contaminated elements carefully, to ensure that dirt cannot enter the carburetor.

AIR CLEANER TYPE 102S

It has a single filter element and is intended primarily for circuit racing, where conditions are less damaging than the very dusty, loose surfaces of off-road operation for which the double-element Type 101 and 102 Air Cleaners are recommended.

The lower height of the Super Air-Cleaner 102S also facilitates easier installation in cars where available space may be restricted.

INSTALLATION OF AIR CLEANER

- Carefully clean the carburetor, removing any old adhesive or sealant that may have been previously used on the outside of the air intake.
- Press the air cleaner body firmly over the carburetor air intake. Make sure that the outer rim of the air intake engages the internal annular groove in the air cleaner: failure to do so may result in the air cleaner falling off.

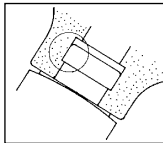

- Position the air cleaner correctly, so that it does not foul the cylinder-head or obstruct the needle-valve.

INSTALLING THE FILTER ELEMENT

- The element is already impregnated with a special filter oil. As this oil is very sticky, take care, when handling it, to prevent dust or dirt from adhering to the element. If your fingers become contaminated, wash them with soap and water.
- During storage, the oil may have become unevenly dispersed through the element. This will be indicated if the blue colour of the element material appears patchy. In this case, place the element in a small plastic bag and gently rub it between finger and thumb to redistribute the oil.

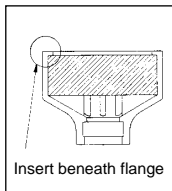

REPLACEMENT OF ELEMENT

- It is advisable to replace the filter element with a new one after not more than one hour of running time. Always remove contaminated elements carefully, to ensure that dirt cannot enter the carburetor.

NOTES CONCERNING THE RECOIL STARTER

(15CV-RX ONLY)

REMINDER!

- ◆ Do not attempt to disassemble the recoil starter. If you do so, the very strong spring inside will be suddenly ejected. This can be very dangerous.
- ◆ Do not extend the starter cord more than 45cm(18"). Do not abruptly release the operating handle. Allow the cord to rewind smoothly while still holding the handle.
- ◆ Pull the operating handle straight out when starting the engine, so that the cord does not rub against the vehicle body or engine.
- ◆ This will help prevent the cord from being damaged by abrasion or engine heat.
- ◆ Try to avoid spilling fuel over the starter unit and its cord. Some fuels have a detrimental effect on these parts.

- ◆ **The starter prevents the engine from being rotated in the wrong direction. The unit will be damaged if you attempt to force the fly-wheel in the opposite direction (i.e. clockwise when viewed from the crankshaft end).**

NOTE:

Because, in the interests of personal safety, dismantling of the starter mechanism is strongly discouraged, the Recoil Starter is available for replacement only as a pre-assembled unit.

However, some related parts, such as Starting Shaft and Rear Adaptor, are obtainable separately. (See Parts List.)

GLOWPLUG

Since the compatibility of glowplug and fuel may have a marked effect on performance and reliability, it may be worthwhile to choose the R/C type plug found most suitable after tests. Recommended O.S. plugs are No.8, A5 and A3. Carefully install plug finger-tight, before final tightening with the correct size plug wrench.

The role of the glowplug

With a glowplug engine, ignition is initiated by the application of a 1.5-volt power source. When the battery is disconnected, the heat retained within the combustion chamber remains sufficient to keep the plug filament glowing, thereby continuing to keep the engine running. Ignition timing is 'automatic' : under reduced load, allowing higher rpm, the plug becomes hotter and, appropriately, fires the fuel/air charge earlier; conversely, at reduced rpm, the plug become cooler and ignition is retarded.

Glowplug life

Particularly in the case of very high performance engines, glowplugs must be regarded as expendable. However, plug life can be extended and engine performance maintained by careful use, i.e.:

- Install a plug suitable for the engine.
- Use fuel containing a moderate percentage of nitromethane unless more is essential for racing events.
- Do not run the engine too lean and do not leave the battery connected while adjusting the needle.

When to replace the glowplug

Apart from when actually burned out, a plug may need to be replaced because it no longer delivers its best performance, such as when:

- Filament surface has roughened and turned white.
- Filament coil has become distorted.
- Foreign matter has adhered to filament or plug body has corroded.
- Engine tends to cut out when idling.
- Starting qualities deteriorate.

TOOLS, ACCESSORIES, etc.

The following items are necessary for operating the engine.

FUEL

Use only top quality methanol-based model engine fuel. For consistent performance and long engine life, it is advisable to use fuel containing AT LEAST 18% lubricant. This engine is designed to run on both low and high nitromethane content fuels, i.e. from mild mixtures containing a few percent of nitromethane, up to high-speed racing fuels containing 40% nitromethane. Generally, power output is increased—up to a certain point—as the nitromethane content of the fuel is increased.

As a starting point, we recommend a fuel containing 10-20% nitromethane, changing to a fuel containing more nitro only if necessary. When the nitro content of the fuel is increased or the brand of fuel is changed, it is advisable to initially run the engine with a richer needle-valve setting, so that the optimum setting for the new fuel may be rechecked as described in the RUNNING-IN paragraphs. When engines are run at very high speeds and on high-nitro fuels, glowplug elements do not last so long.

Reminder!

 **Model engine fuel is poisonous. Do not allow it to come into contact with the eyes or mouth. Always store it in a clearly marked container and out of the reach of children.**

 **Model engine fuel is also highly flammable. Keep it away from open flame, excessive heat, sources of sparks, or anything else which might ignite it.**

ELECTRIC STARTER AND STARTER BATTERY

Use a 12-volt electric starter with suitable battery for starting the engine. (15CV-R/R(P))

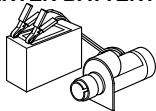

BATTERY INTEGRATED GLOWPLUG HEATER

Commercially available handy glowplug heater in which the glowplug battery and battery leads are integrated.

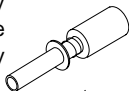

FUEL PUMP

For filling the fuel tank, a simple, polyethylene "squeeze" bottle, with a suitable spout, is required.



LONG SOCKET WRENCH

Recommended for easy removal and replacement of the angled and recessed glowplug, the O.S.Long Socket Wrench incorporates a special grip.

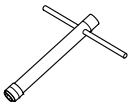

SILICONE FUEL LINE

Heatproof silicone tubing of approx. 5mm o.d. and 2mm i.d. is required for the connection between the fuel tank and engine.

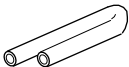

CARBURETOR CONTROLS (10C)

Three adjustable controls are provided on this carburetor.

- **The Needle-Valve:**

For adjusting the mixture strength when the throttle is fully open.

- **The Mixture Control Screw:**

For adjusting the mixture strength at part-throttle and idling speeds, to obtain steady idling and smooth acceleration to mid speeds.

- **The Throttle Stop Screw:**

For setting the minimum idling speed.

NOTE:

Readjustment may be necessary, occasionally to allow for changes in fuel formula, gear ratio or clutch engagement point.

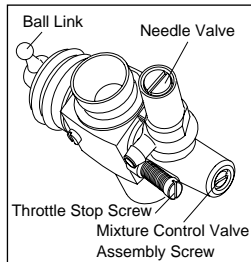

CARBURETOR CONTROLS (10E-R)

Three adjustable controls are provided on this carburetor.

- **The Needle-Valve:**

For adjusting the mixture strength when the throttle is fully open.

- **The Mixture Control Screw:**

For adjusting the mixture strength at part-throttle and idling speeds, to obtain steady idling and smooth acceleration to mid speeds.

- **The Throttle Stop Screw:**

For setting the minimum idling speed:

NOTE:

Readjustment may be necessary, occasionally to allow for changes in fuel, gear ratio or clutch engagement point.

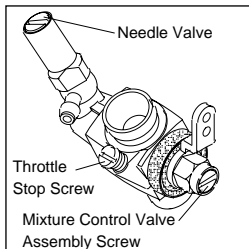

PRESSURIZED FUEL SYSTEM

- The somewhat violent changes of vehicle attitude that occur in off-road running, combined with the fact that, in buggy type cars, the fuel tank is often located some distance from the carburetor, means that fuel 'head' at the carburetor can vary and upset running. Therefore, it is recommended that a muffler pressurized fuel feed system be used.
- Never run your vehicle without installing the air cleaner. Dust and dirt that may otherwise be drawn into the engine will rapidly shorten its life.

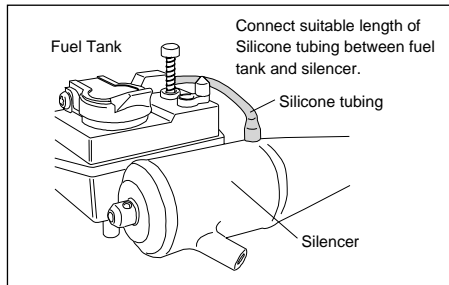

STARTING THE ENGINE & RUNNING-IN ('Breaking-in')

The following procedure is suitable for these engines when the O.S. T-1020 tuned silencer and a fuel containing up to 30% nitromethane are used.

- Use the same fuel as is to be employed for all initial running and containing NOT LESS THAN 18% lubricant.

- Temporarily remove the glowplug to check that it glows bright red when energized.

- Re-check the needle-valve and throttle settings. Turn the needle-valve clockwise slowly and gently until it stops. This is the fully closed position. Do not use force to turn the needle-valve beyond this point.

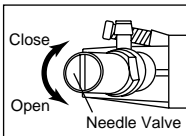

- Open the Needle-Valve 2 turns from the fully closed position.

- ◆ In case of the 10C carburetor

- Switch on the transmitter and receiver and set the throttle very slightly open from the idling position.

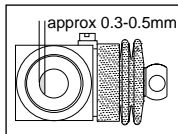

- ◆ In case of the 10E-R carburetor

- Set the throttle-stop screw so that the minimum throttle opening (idle setting) is approximately 1.0mm.

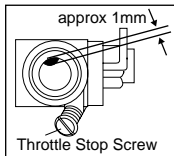

- DO NOT energize glowplug, but apply electric starter to draw fuel to carburetor.

- Now connect glowplug battery lead to heat the plug filament and start the engine.

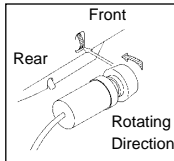

- In case of the 15CV-RX

- Push the choke button on the fuel tank several times to deliver the fuel to the carburetor. (Do not over-prime or the recoil starter cannot be pulled.)

- Pull the starter handle briskly straight out several times to start the engine.

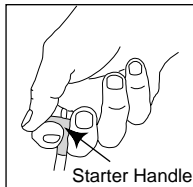

Remember!

It is vitally important to set the throttle at the correct position before attempting to start the engine. If the engine is allowed to run with the throttle too far open under "no load" conditions, it will rapidly overheat and may be seriously damaged.

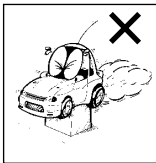

- When the engine starts, first allow it to operate in short runs on its very rich starting settings, with the glowplug battery still connected and with its driving wheels clear of the ground. The rich mixture will, under these conditions, provide adequate lubrication and cooling, indicated by profuse smoke from the exhaust.
- Next, disconnect the glowplug battery and try running the car on the track. If the engine stalls, open the throttle fractionally, but try to keep the engine running as rich as possible: if it stops because of being excessively over-rich, close the Needle-Valve 30° and try again.
- Run the car on the track until one tank of fuel has been consumed, then close the Needle-Valve 30° and run the car for another full tank of fuel. Repeat this procedure until 5 more tanks of fuel have been consumed, during which time the throttle may

be opened for brief bursts of increased power. If the engine stops at medium speeds, close the Mixture Screw 45-90°.

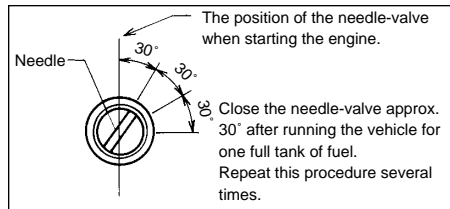

- To stop the engine, close the throttle to idling speed, then shut it off completely with the trim lever on the transmitter. To cut off the fuel supply, pinch the fuel delivery tube to the carburetor.

Remember!

If the engine should need to be disassembled (e.g. for cleaning or minor parts replacement) it is advisable to return the Needle-Valve to the original rich, starting setting and check whether further running-in time is required before the car is raced again. In the event of any major working parts (e.g. piston/cylinder liner assembly) being replaced, the complete running-in should be repeated.

IF THE ENGINE FAILS TO START

Check the following:

- Glowplug battery discharged or glowplug defunct.
- Fuel not reaching carburettor.
- Engine flooded. Do not over-prime. (This could also cause hydraulic lock and damage the engine on application of the electric starter.)

Remove glowplug, close needle-valve and apply starter to pump out surplus fuel. At this time cover the plug hole with a rag so that splashing fuel will not get into your eyes or mouth.

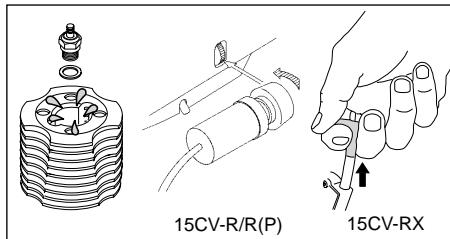

FINAL ADJUSTMENT

- Run the vehicle (with throttle fully open) over the longest available straight course, in order to observe the model's speed. Next return the car to the starting point, close the Needle-Valve 30° and repeat the run, taking note of the improvement in performance. Continue with further runs, gradually reducing the Needle-Valve setting and aiming to achieve the highest straight-line speed. Remember, however, that, if the Needle-Valve is shut down too far, the engine will overheat and, accompanied by visibly diminished exhaust smoke, the model will lose speed. At this point, throttle down immediately, stop the vehicle and reopen the Needle-Valve 30°.
- Having established the optimum Needle-Valve setting, check the Mixture Control Valve setting as follows.
- With the engine running, close the throttle and allow it to idle for about five seconds, then reopen the throttle fully. If, at this point, the engine puffs out an excessive amount of smoke and the vehicle does not accelerate smoothly and rapidly, it is probable that the idling mixture is too rich.

- In this case, turn the Mixture Control Valve clockwise 45~90°. If, on the other hand, the engine tends to speed up momentarily and then cut out abruptly when the throttle is opened, the idling mixture is too lean. Correct this by turning the Mixture Control Valve counter-clockwise 45~90°.

NOTE:

Mixture Control Valve adjustment should be made in steps of not more than 45~90°, carefully checking the effect, on throttle response, of each small adjustment.

- Carry out adjustments patiently, under actual running conditions, until the engine responds quickly and positively to the throttle control.

Warning!

Mixture adjustments (whether via the Mixture Control Valve, or the Needle-Valve) cannot be made accurately under 'no-load' conditions, which, in any case, are not advised, since such operation carries the risk of seriously damaging the engine through over-revving and overheating.

- With the optimum mixture control position, light smoke is visible during high speed running, and the engine revolutions increase smoothly during acceleration. Remember that, if the engine is operated with the fuel/air mixture slightly too lean, it will overheat and run unevenly. As with all engines, it is advisable to set both needle-valve and mixture control screw very slightly on the rich side of the best rpm setting, as a safety measure.
- If the engine runs too fast with the throttle closed, the throttle stop screw should be turned counter-clockwise to allow the throttle opening to be reduced.
- Finally, beyond the nominal break-in period, a slight readjustment toward a leaner needle setting may be required to maintain performance.

CARBURETOR CLEANLINESS

The correct functioning of the carburetor depends on its small fuel orifices remaining clear.

■ BALL LINK AND SLIDE VALVE EXTENSION

(In case of the 10C carburetor)

It is seldom necessary to separate the slide-valve extension from the slide-valve itself. For cleaning, withdraw this complete sub-assembly from the carburetor body after removing the slide-valve guide screw. Then wash with methanol or glow-fuel.

(Note: take care not to lose the guide screw; it is a special one.) When it is necessary to adjust the ball-link position, loosen the ball-link retaining screw with a 2.5mm hexagon key, re-align the ball-link and re-tighten the screw firmly.

■ REALIGNMENT OF MIXTURE CONTROL VALVE

In the course of making carburetor adjustments, it is just possible that the Mixture Control Valve may be inadvertently screwed in or out too far and thereby moved beyond its effective adjustment range. Its basic position can be found by first rotating the Mixture Control Valve until its slotted head is flush with the carburetor body. The valve is then screwed in exactly 2.5 turn to re-establish its neutral position.

In case of the 10C carburetor

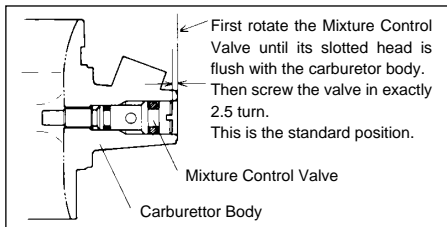

In case of the 10E-R carburetor

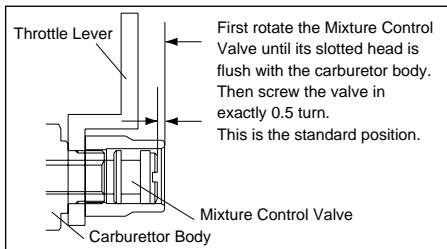

CARE AND MAINTENANCE

1. The minute particles of foreign matter, that are present in any fuel may, by accumulating and partially obstructing fuel flow, cause engine performance to become erratic and unreliable.

O.S. 'Super-Filters' (large and small) are available, as optional extras, to deal with this problem.

One of these filters, fitted to the outlet tube inside your refueling container, will prevent the entry of foreign material into the fuel tank. It is also recommended that a good in-line filter be installed between the tank and carburetor.

2. Do not forget to clean the filters regularly to remove dirt and lint that accumulate on the filter screens.

Also, clean the carburetor itself occasionally.

3. At the end of each operating session, drain out any fuel that may remain in the fuel tank. Afterwards, energize the glow-plug and try to restart the engine, to burn off any fuel that may remain inside the engine. Repeat this procedure until the engine fails to fire. Do this while the engine is still warm.

4. Then, inject some after-run oil into the engine, and rotate the engine with an electric starter for 4 to 5 seconds to distribute the oil to all the working parts.

Note:

Do not inject after-run oil into the carburetor as this may cause the O-rings inside the carburetor to deteriorate. These procedures will reduce the risks of starting difficulties or corrosion after a period of storage.

5. Finally, when cleaning the exterior of the engine, use methanol or kerosene. Do not use gasoline or any solvent that might damage the silicone fuel tubing.

Caution:

The rear crankshaft bearing of this engine uses a special plastic retainer. If the front housing needs to be heated to remove or replace the bearing, do not allow the bearing to exceed 120°C (248°F), otherwise it may be damaged and rendered unserviceable.

■ O.S. Glow Plug



No.8 (71608001)
A3 (71605300)
A5 (71605100)

■ Super Air Cleaner

102 (72403200)

102S (72403202)

■ 101,102 Filter Elements
(72403120) (6pcs.)

■ 10C Automatic
Carburettor
(21286000)

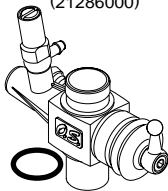

■ Exhaust Header Pipes

For MUGEN MTX
(72103150)

For Kyosho Super10
(72103110)

For Tamiya TGX
(72103120)

For Kyosho
V-ONE R,S
(72103160)



For Kyosho Spider & HPI Nitro
(72103140)

For Tamiya TG10
(72103130)



■ T-1020 Tuned Silencer
(72103020)

■ T-1030 Tuned Silencer
(72103030)



■ Super Joint Tube 15
(72103310)



■ Crankshaft Clamp
1521 (71530200)



■ Long Socket Wrench
With Plug Grip
(71521000)

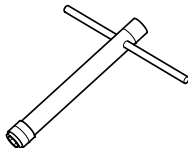

■ Dust Cap Set

φ3 (73300305)

For Carburettor Nipple

φ7 (73300712)

For T-1020 Tuned
Silencer

φ10 (73301012)

For 10C,10E-R
Carburettor

15CV-R EXPLODED VIEW

⑨ ⑩ Not included in 15CV-R(S)

—22—

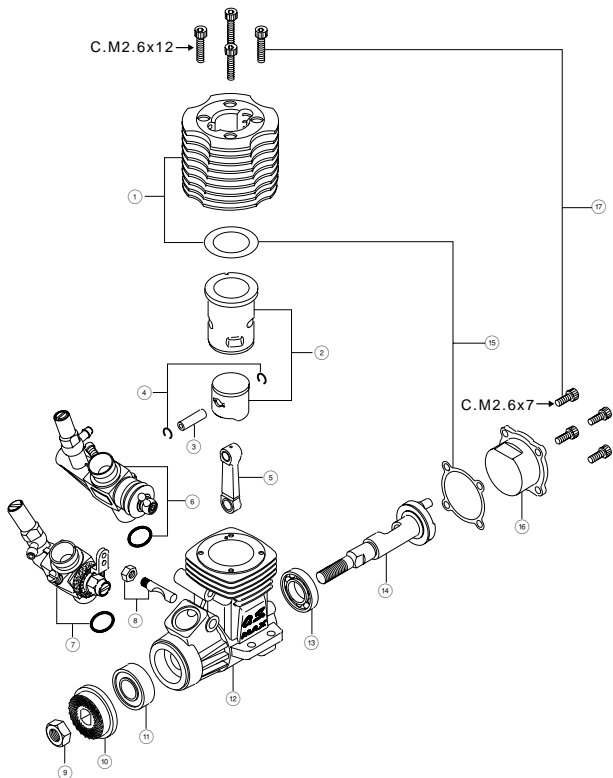

* Type of screw C...Cap Screw M...Oval Fillister-Head Screw
 F...Flat Head Screw N...Round Head Screw S...Set Screw

15CV-R ENGINE PARTS LIST

No.	Code No.	Description
①	21504600	Heatsink Head
②	21503020	Cylinder & Piston Assembly
③	21806000	Piston Pin
④	23817000	Piston Pin Retainer(2pcs.)
⑤	21255000	Connecting Rod
⑥	21286000	Carburetor Complete (Type 10C)
⑦	21481020	Carburetor Complete (Type 10E-R)
⑧	21481700	Carburetor Retainer
⑨	20810007	Propeller Nut
⑩	21408000	Drive Hub
⑪	22631020	Crankshaft Ball Bearing (Front)
⑫	21501030	Crankcase
⑬	21230020	Crankshaft Ball Bearing (Rear)
⑭	21252000	Crankshaft
	21252010	Crankshaft (15CV-R(S))
⑮	21514010	Gasket Set
⑯	21257000	Cover Plate
⑰	21213000	Screw Set
	71608001	Glow Plug No.8
	72403200	Super Air Cleaner 102 (W/3 filter elements)
	72403210	102 Cleaner Body
	72403120	101,102 Filter Elements (6pcs.)

The specifications are subject to alteration for improvement without notice.

15CV-RX EXPLODED VIEW

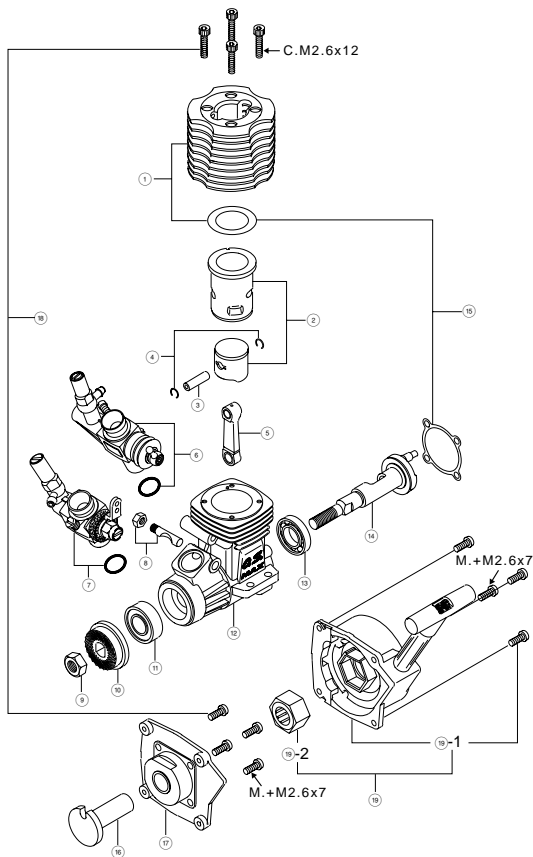

* Type of screw C...Cap Screw M...Oval Fillister-Head Screw
 F...Flat Head Screw N...Round Head Screw S...Set Screw

15CV-RX ENGINE PARTS LIST

No.	Code No.	Description
①	21504600	Heatsink Head
②	21503020	Cylinder & Piston Assembly
③	21806000	Piston Pin
④	23817000	Piston Pin Retainer(2pcs.)
⑤	21255000	Connecting Rod
⑥	21286000	Carburetor Complete (Type 10C)
⑦	21481020	Carburetor Complete (Type 10E-R)
⑧	21481700	Carburetor Retainer
⑨	20810007	Propeller Nut
⑩	21408000	Drive Hub
⑪	22631020	Crankshaft Ball Bearing (Front)
⑫	21251000	Crankcase
⑬	21230020	Crankshaft Ball Bearing (Rear)
⑭	21252040	Crankshaft
⑮	21514010	Gasket Set
⑯	21421200	Starting Shaft
⑰	21421300	Rear Adaptor
⑱	21313030	Screw Set
⑲	73003000	No.5 Recoil Starter Assembly
⑲-1	73003100	No.5 Recoil Starter Body
⑲-2	73003200	No.5 One-way Clutch
	72404000	Engine Mount Spacer
	71608001	Glow Plug No.8
	72403200	Super Air Cleaner 102 (W/3 filter elements) [off -road]
	72403210	102 Cleaner Body
	72403120	101,102 Filter Elements (6pcs.)

The specifications are subject to alteration for improvement without notice.

15CV-R(P) EXPLODED VIEW

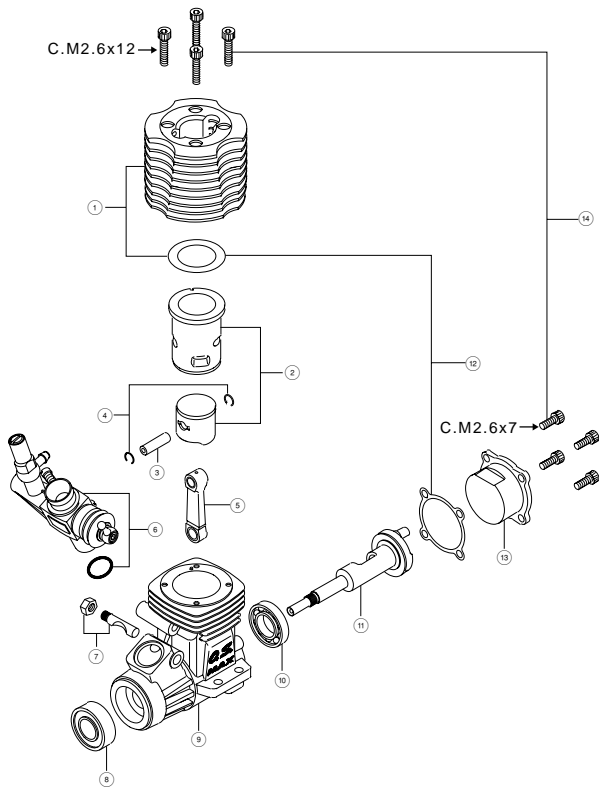

* Type of screw C···Cap Screw M···Oval Fillister-Head Screw
 F···Flat Head Screw N···Round Head Screw S···Set Screw

15CV-R(P) ENGINE PARTS LIST

No.	Code No.	Description
①	21504600	Heatsink Head
②	21503020	Cylinder & Piston Assembly
③	21806000	Piston Pin
④	23817000	Piston Pin Retainer(2pcs.)
⑤	21255000	Connecting Rod
⑥	21286000	Carburetor Complete (Type 10C)
⑦	21481700	Carburetor Retainer
⑧	22631020	Crankshaft Ball Bearing (Front)
⑨	21501030	Crankcase
⑩	21230020	Crankshaft Ball Bearing (Rear)
⑪	21252020	Crankshaft
⑫	21514010	Gasket Set
⑬	21257000	Cover Plate
⑭	21213000	Screw Set
	71608001	Glow Plug No.8
	72403200	Super Air Cleaner 102(W/3 filter elements)
	72403210	102 Cleaner Body
	72403120	101,102 Filter Elements (6pcs.)

The specifications are subject to alteration for improvement without notice.

10C CARBURETOR EXPLODED VIEW & PARTS LIST

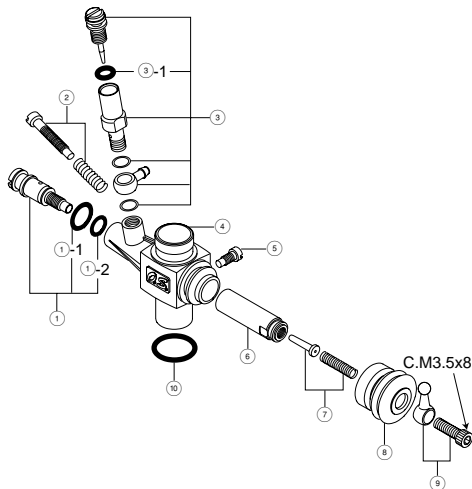

No.	Code No.	Description
①	21285600	Mixture Control Valve Assembly
①-1	46066319	"O" Ring(L) (2pcs.)
①-2	22781800	"O" Ring(S) (2pcs.)
②	21285640	Throttle Stop Screw
③	21285901	Needle Valve Assembly
③-1	27881820	"O" Ring (2pcs.)
④	21286100	Carburetor Body
⑤	21285220	Slide Valve Guide Screw
⑥	21286200	Slide Valve
⑦	21286400	Metering Needle Assembly
⑧	21881320	Dust Cover
⑨	23818420	Ball Link No.4
⑩	22615000	Carburetor Rubber Gasket

* Type of screw

C···Cap Screw M···Oval Fillister-Head Screw

F···Flat Head Screw N···Round Head Screw S···Set Screw

The specifications are subject to alteration for improvement without notice.

10E-R CARBURETOR EXPLODED VIEW & PARTS LIST

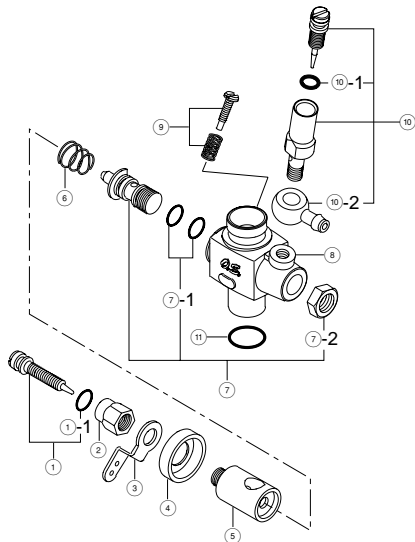

No.	Code No.	Description
①	21481600	Mixture Control Screw
①-1	27881820	"O" Ring (2pcs.)
②	21481420	Throttle Lever Fixing Nut
③	22681419	Throttle Lever
④	21283210	Dust Cover
⑤	21481200	Carburetor Rotor
⑥	22481506	Rotor Spring
⑦	21283962	Nozzle Assembly
⑦-1	24881824	"O" Ring
⑦-2	21283961	Locknut
⑧	21481120	Carburetor Body
⑨	22681310	Throttle Stop Screw
⑩	21481900	Needle Valve Assembly
⑩-1	27881820	"O" Ring (2pcs.)
⑩-2	21481950	Fuel Inlet
⑪	22615000	Carburetor Rubber Gasket

The specifications are subject to alteration for improvement without notice.

15CV-R THREE VIEW DRAWING Dimensions(mm)

SPECIFICATIONS

■ Displacement	2.49 cc (0.152 cu.in.)
■ Bore	15.2mm (0.598 in.)
■ Stroke	13.7mm (0.539 in.)
■ Practical R.P.M.	4,000~36,000 r.p.m.
■ Power output	1.2 bhp / 31,000 r.p.m.
■ Weight	195g(6.88oz.)

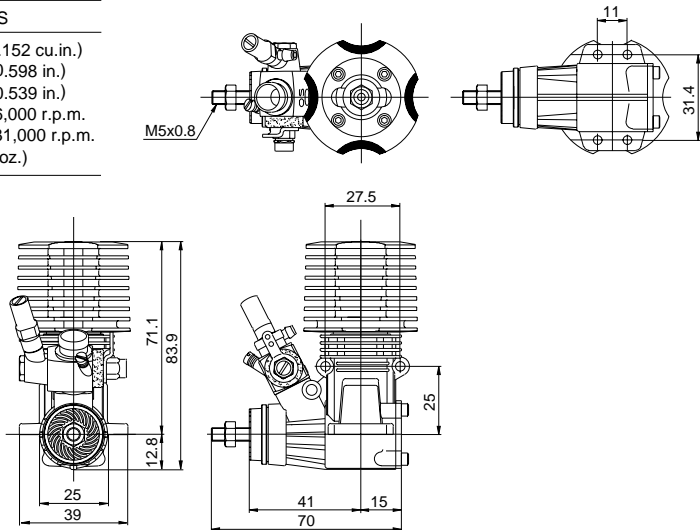

15CV-RX THREE VIEW DRAWING Dimensions(mm)

SPECIFICATIONS

■ Displacement	2.49 cc (0.152 cu.in.)
■ Bore	15.2mm (0.598 in.)
■ Stroke	13.7mm (0.539 in.)
■ Practical R.P.M.	4,000~36,000 r.p.m.
■ Power output	1.2 bhp / 31,000 r.p.m.
■ Weight	253g(8.924oz.)

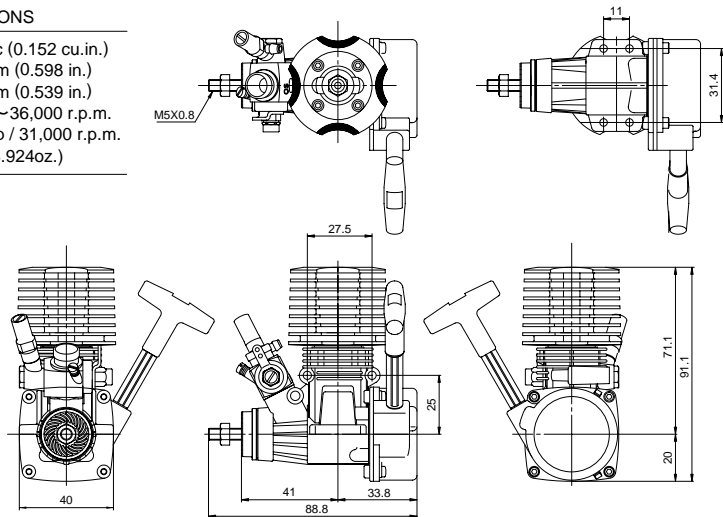

15CV-R(P) THREE VIEW DRAWING Dimensions(mm)

SPECIFICATIONS

■ Displacement	2.49 cc (0.152 cu.in.)
■ Bore	15.2mm (0.598 in.)
■ Stroke	13.7mm (0.539 in.)
■ Practical R.P.M.	4,000~36,000 r.p.m.
■ Power output	1.2 bhp / 31,000 r.p.m.
■ Weight	193.2g(6.82oz.)

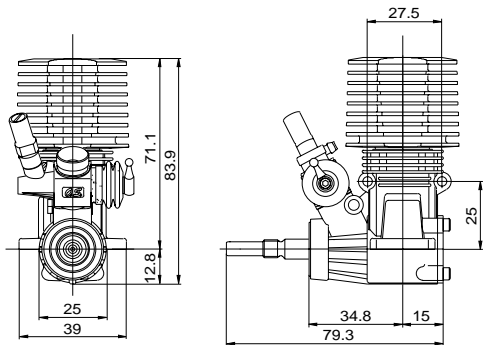
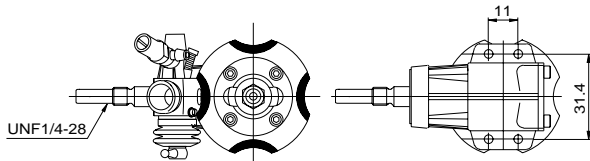



O.S. ENGINES MFG.CO.,LTD.

6-15 3-Chome Imagawa Higashisumiyoshi-ku
Osaka 546-0003, Japan TEL. (06) 6702-0225

FAX. (06) 6704-2722

URL : <http://www.os-engines.co.jp>