

ASSOCIATED 1:10 SCALE NITRO 4WD ON ROAD MANUAL

**NITRO
TC3
RTR**



**INSTRUCTION MANUAL FOR THE
TEAM ASSOCIATED RTR NITRO TC3**



NITRO TC3 RTR



Thank you for purchasing this Team Associated product. This manual contains steps and instructions you will use to set up your car. Please read this entire manual before attempting to start your car. Follow the directions in this manual closely to reduce any problems on start up. We hope that you will enjoy your new Team Associated car.

RTR NTC3

Already assembled!

Includes:

- Oil-filled shocks.
- Precision rubber-sealed bearings.
- Tuned pipe and manifold.
- Universal driveshafts.
- 6061 T-6 aluminum chassis.



Log on to www.rc10.com and get your FREE computer wallpaper!

EQUIPMENT REQUIRED TO RUN YOUR RTR NITRO TC3

WARNING!

Do not use a power screwdriver to install screws into nylon, plastic, or composite materials. The fast rotation speed can heat up the screws being installed. They can break the molded parts or strip the threads during installation.

for the RTR Nitro TC3.

- 1 Glow plug starter.
 - 2 Model car fuel.
 - 3 Fuel bottle.
- Receiver battery.
Radio batteries.



YOU WILL NEED THESE TOOLS TO WORK ON YOUR KIT

- 1 Phillips screwdriver #2.
- 2 1/8" flat head screwdriver.
- 3 5/16" driver or glow plug wrench.
- 4 Needle-nose pliers.
- 5 Thread locking compound (#1596 Locking Adhesive or equivalent)
- 6 Super glue or tire adhesive (#1597).
- 7 Hobby knife **WARNING!** This knife cuts plastic and fingers with equal ease, so be careful.
- 8 Precision ruler.

YOUR ENGINE MAY REQUIRE TOOLS NOT LISTED HERE.

- 1
- 2
- 3
- 4
- 5
- 6
- 7
- 8

TOOLS SUPPLIED

Allen wrenches (#6950)

, .050", 1/16", 3/32", 5/64"

Molded tools (#6956):

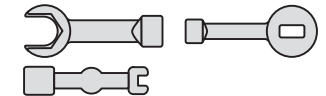

Camber/toe-in gauge (#1719)



Track width/ride height tool (#1719)





CUSTOMER SUPPORT

(714) 850-9342, ext. 624
FAX (714) 850-1744
web site: <http://www.TeamAssociated.com/>

READ THIS BEFORE BUILDING

READ THE MANUAL!

Read the manual before starting your kit and before contacting us for help. *"Hello, Associated, I need some help."* *"Did you read the manual?"*

This manual is for your reference. It will help you to disassemble and reassemble your RTR Nitro TC3. Read the manual before contacting us for help.

SUPPLEMENTAL SHEETS

We are constantly updating parts to improve our kits. These changes, if any, will be noted in supplementary sheets located in a parts bag or inside the box. When a supplement is found, attach it to the appropriate section of the manual.

MANUAL FORMAT

When we refer to left and right sides of the car, we are referring to the driver's point of view from inside the car.

You'll see a car angled in a particular direction in several steps. The angle shows you which way the part is being viewed, helping you to tell front and rear, left and right.

The "BAG A" headings refer to the unassembled kit versions of this NTC3. They are not relevant to your RTR version.

BAG A

REMOVE THESE PARTS FOR:
Step 1

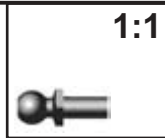

3857, qty 3
short special
ball end, black



2228, qty 1
swing rack



2228, qty 1
swing rack arm



3929, qty 1
spring

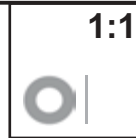

2228, qty 1
.125 x .250 rack
shim



6918, qty 1
4-40 x 1/2" screw



4449, qty 1
4-40 locknut

step 1

SWING RACK ASSEMBLY

- 1 Attach two #3857 short ball ends to the #2228 swing rack and one to the #2228 swing rack arm.
- 2 Slide the #3929 spring and #2228 rack shim onto the #6918 screw. Slide the screw assembly through the bottom of the swing rack.
- 3 Attach the #2228 swing rack arm to the swing rack with a #4449 locknut.
- 4 Tighten down the screw until the screw end is even with the top of the nut.

Match this number to the text to find your way faster

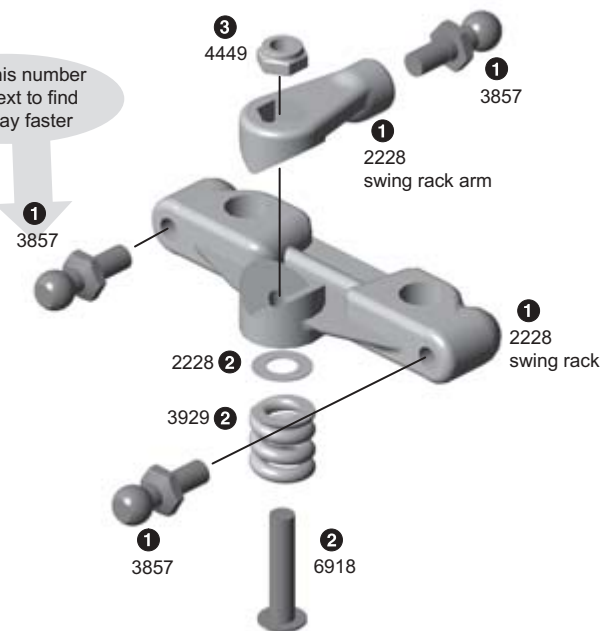

TOOLS USED

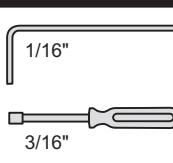

BAG A

TOOLS USED

REMOVE THESE PARTS FOR:
Steps 2-3



2229, qty 2
pivot post



7337, qty 2
washer



2229, qty 2
screw



2229, qty 2
swing rack mounting post



2228, qty 2
swing rack bellcrank arm

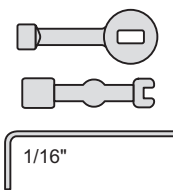

1/16"



2224, qty 1
NTC3 chassis



2234, qty 2
3/16 x 5/16 .109 bushing
unflanged



6291, qty 2
4-40 X 1/4 screw



2234, qty 2
1/8 x 1/4 bushing



6472, qty 2
nylon locknut

step 2

- Slide the #2229 pivot post through the swing rack followed by a #2228 swing rack bellcrank arm.
- Slide one #7337 washer onto the #2229 screw then slide the screw through the pivot post. Now tighten down the screw, but not to the point of damaging the threads.

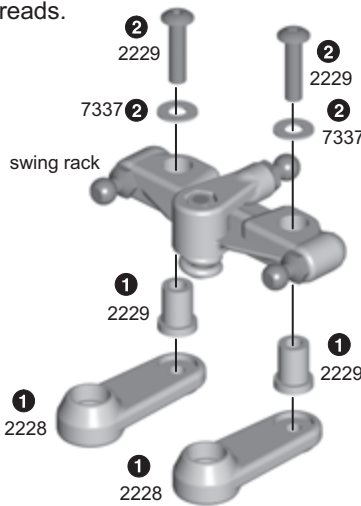

step 3

SWING RACK TO CHASSIS

- Install the two #2229 swing rack mounting posts to the #2224 chassis with #6291 screws.
- Slide one #2234 3/16 x 5/16" bushing onto each post. Slide the swing rack assembly down, making sure the mounting posts are in front of the rack.
- Now insert the #2234 1/8 x 1/4" bushings into the rack assembly where shown.
- Fasten the swing rack down with #6472 nylon locknuts. Tighten down each nut until the swing rack doesn't move freely. Then loosen each nut a 1/4 turn or until it moves freely.

CAR SHOWS VIEWING ANGLE

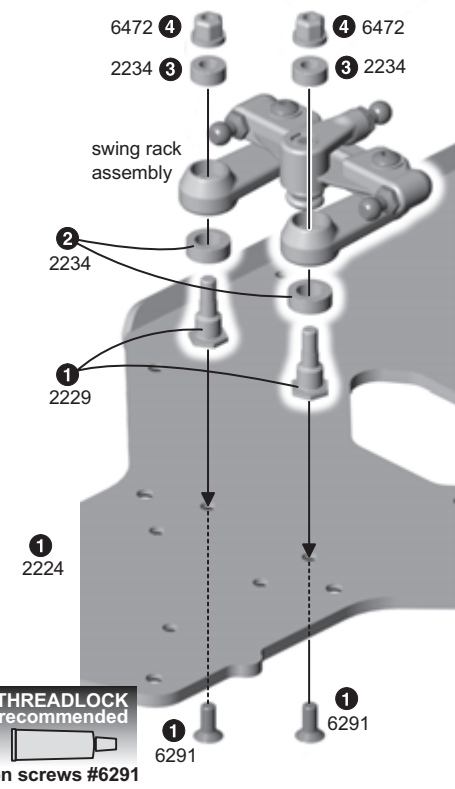

THREADLOCK recommended
on screws #6291

BAG B

TOOLS USED

REMOVE THESE PARTS FOR:
Steps 1-3

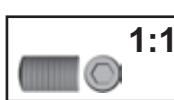

3865, qty 4
set screw



2233, qty 2
front a-arms,
right & left



2231, qty 1
front arm rear
mount



2242, qty 4
hinge pin

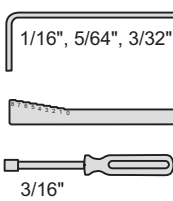

1/16", 5/64", 3/32"

3/16"



2243, qty 2
rear a-arms,
right & left



2231, qty 1
rear arm front
mount



2257, qty 2
ball end



2240, qty 8
5-40 x 7/16 screw



2223, qty 1
front bumper

PUT ASIDE THE #2233 & #2243 UPPER ARMS UNTIL THEY ARE CALLED FOR IN BAG E.



step 1

FRONT ARM ASSEMBLY

- 1 Install a #3865 set screw into each of the #2233 front arms, making sure there is a right and a left side. (We will do the final screw adjustment in step 3.)
- 2 Attach the #2231 front arm, rear mount to the chassis with two #2240 screws.
- 3 Slide the #2242 hinge pins through the #2233 arms. Slide the pins with the arms into the arm mount.
- 4 Align the #2223 front bumper/ arm mount with the two hinge pins and slide together. Tighten it down with two #2240 screws.

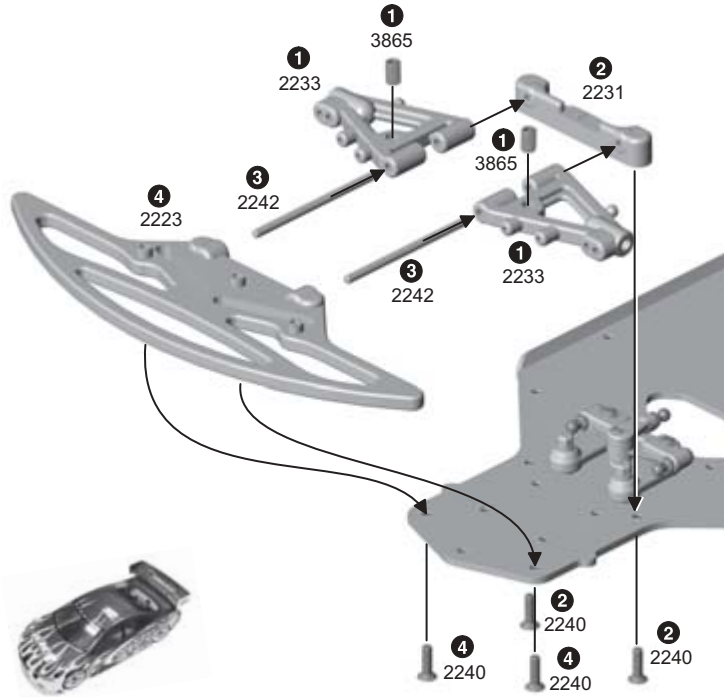

step 2

REAR ARM ASSEMBLY

- 1 Install a #3865 set screw into each of the #2243 rear arms, making sure there is a right and a left side. (We will do the final screw adjustment in step 3.)
- 2 Attach #2231 rear arm front mount to the chassis with two #2240 screws.
- 3 Slide the #2242 hinge pins through the #2243 rear arms. Slide the pins with the arms into the #2231 rear arm front mount.
- 4 Install the two #2257 ball ends into the #2231 rear arm mount. Align the rear arm mount up with the two hinge pins and slide together. Tighten down with two #2240 screws.

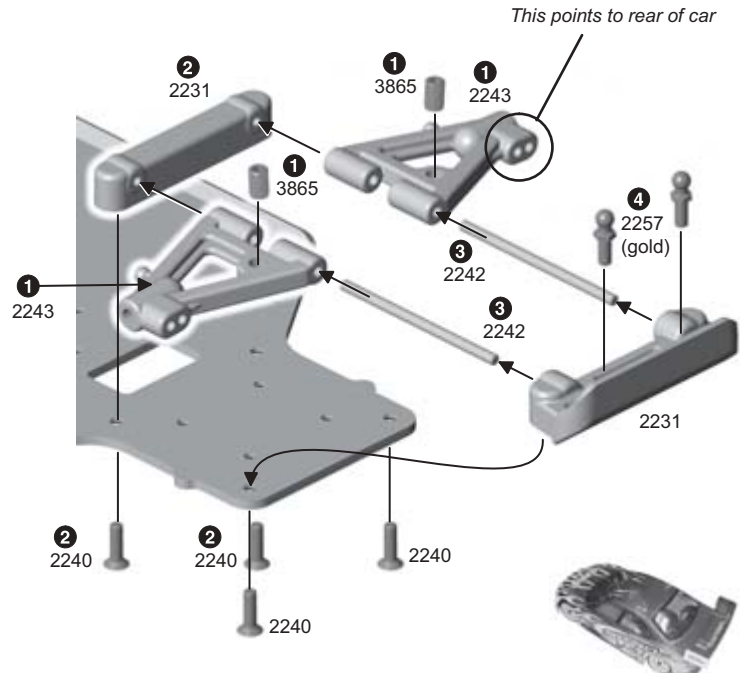

step 3

SETTING DROOP

- 1 Place the supplied #3987 droop gauge on a flat surface. Place the bottom of the chassis on top as shown. Make sure the screws are not resting on the gauge and that you are holding the chassis and gauge flat.
- 2 Slide the gauge out so the shock mounting portion of the front arm rests on step 4. With your 3/32 Allen wrench, adjust the set screw so the outer part of the arm just touches the step. Adjust both front arms.
- 3 Slide the gauge to the rear arms and repeat the adjustment. The shock mounting portion of the rear arms will rest on step 3.

ADJUST DROOP SCREW

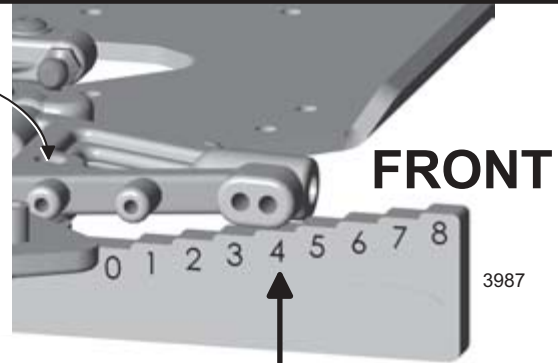

FRONT ARMS REST ON STEP 4

ADJUST DROOP SCREW

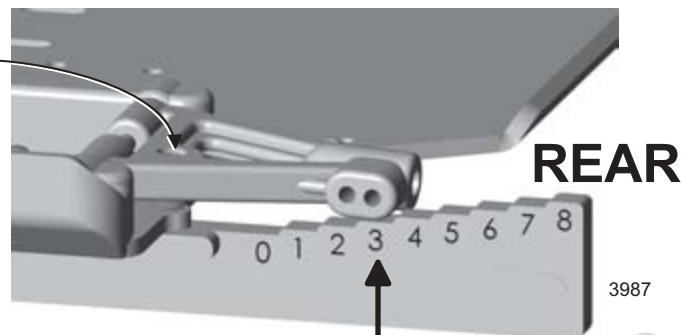

REAR ARMS REST ON STEP 3

BAG C

TOOLS USED

REMOVE THESE PARTS FOR: Steps 1-5



2329, qty 2
ring gear



6591, qty 1
Stealth lube



6909, qty 4
3/16 x 5/16 bearing
unflanged



2332, qty 2
friction disc

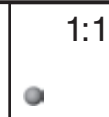

6581, qty 24
diff balls



6582, qty 2
diff spring



2328, qty 2
long outdrive

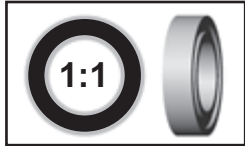
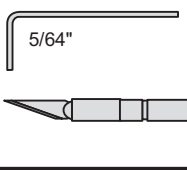

3976, qty 4
3/8 x 5/8 bearing
rubber sealed, unflanged



6573, qty 4
thrust washer



6575, qty 2
diff bolt



6588, qty 1
black grease



6574, qty 12
thrust balls



2328, qty 2
short outdrive



2293, qty 4
outdrive shim



2330, qty 2
T-nut

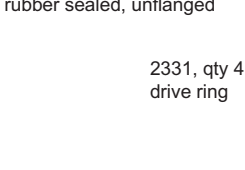

2331, qty 4
drive ring



step 1

DIFFERENTIAL RING GEAR

- 1 Trim any burrs from the edges shown with a hobby knife.
- 2 Slide a #6909 bearing into the #2332 friction disc. Slide the bearing and disc into the center of the #2329 ring gear.
- 3 Add a generous amount of #6591 Stealth lube to the #2329 ring gear holes and friction disc. Push in the twelve #6581 diff balls. Now push the lube back in that came out.

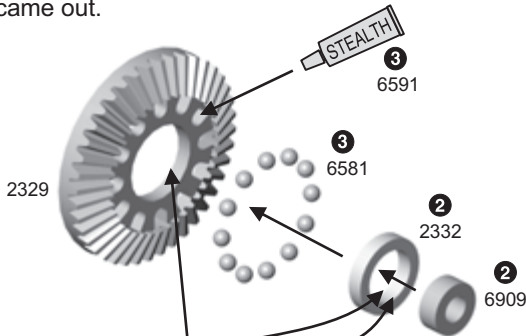

! Trim any burrs from these edges with a hobby knife.

step 2

LONG OUTDRIVE

- 1 Remove any oil residue thoroughly where shown. With a pair of pliers, compress the #6582 spring a few times. Push the #6582 diff spring into the #2328 long outdrive.
- 2 Slide the #2330 T-nut into the long outdrive.
- 3 Insert one #6909 bearing into the face of the long outdrive.
- 4 Add a light coat of #6591 Stealth lube to the long outdrive face as shown. Place a #2331 drive ring on the outdrive face.

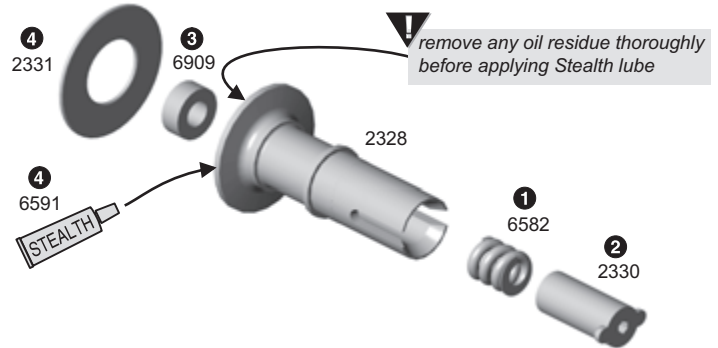

step 3

SHORT OUTDRIVE

- 1 Remove any oil residue thoroughly where shown. Hold the #6573 diff bolt with your 5/64" Allen wrench and slide one #6573 thrust washer onto the #6573 diff bolt.
- 2 Apply a generous amount of #6588 black grease to the washer on the side facing away from the bolt head.
- 3 Place six #6574 balls into the grease against the #6573 bolt and washer. Add the second #6573 washer. The grease will hold the balls in place during assembly, sandwiching the balls and washers.
- 4 Slide the thrust assembly into the #2328 short outdrive, being careful not to lose any of the balls.
- 5 Add a light coat of #6591 Stealth lube to the short outdrive face as shown.
- 6 Place a #2331 drive ring and then the gear assembly on the outdrive.

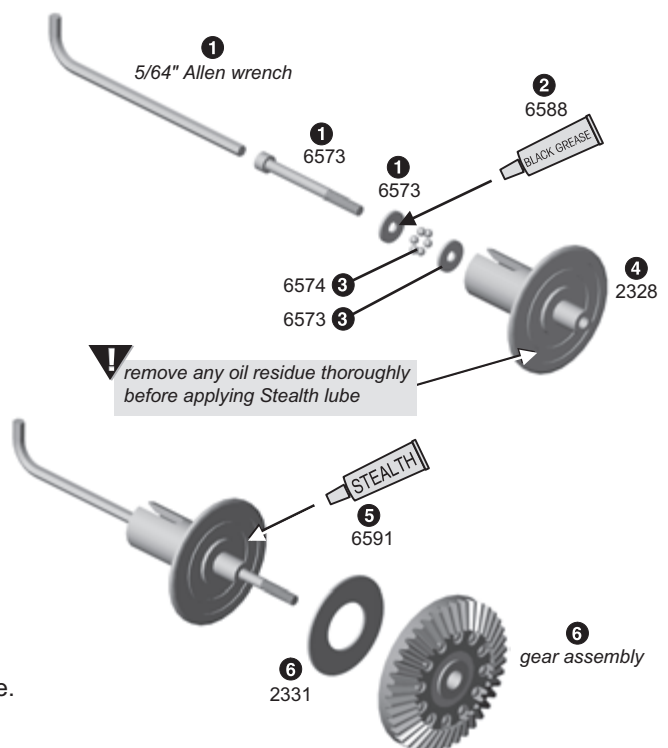

step 4

- 1 Holding the short outdrive assembly still with your 5/64" Allen wrench, place the long outdrive assembly into the face of the short outdrive / gear assembly.

CHECK THE ALIGNMENT

- 2 Tighten the diff together with your 5/64 Allen wrench, but not completely.
NOTE: You may need to hold the T-nut in place when assembling the two outdrives.
- 3 Rotate the diff hubs several times as you are tightening the bolt to check proper alignment of the parts. **READ STEP 4 CAREFULLY.**

ADJUST THE DIFF

- 4 As you tighten the diff bolt, you will notice the T-nut ears moving closer to the bottom of the outdrive slot. This compresses the spring behind the T-nut. The spring should be fully compressed at the same time the T-nut reaches the end of the slot. **CAUTION:** Pay close attention to the feeling when the spring is fully compressed. Do not overtighten the bolt. When you feel the spring fully compressed, loosen the diff bolt 1/4 of a turn for the front and 1/2 of a turn for the rear. Your diff should now operate very smoothly with the outdrives moving in opposite directions. After you have driven the car once, recheck the diff adjustment.
- 5 Now assemble the second diff the same way.

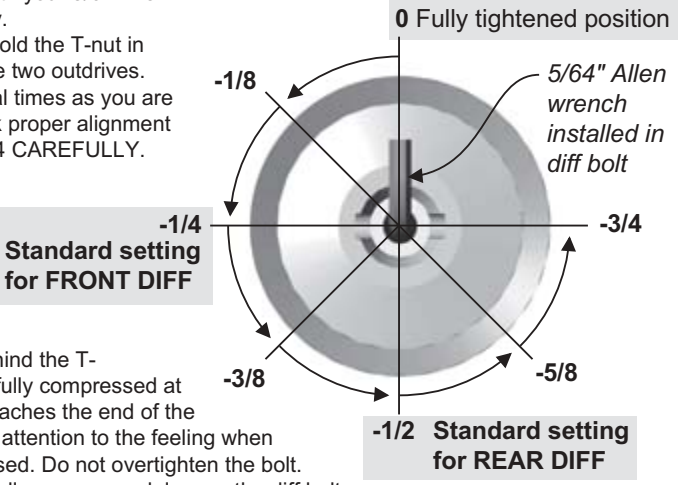

Once you have fully tightened the diff bolt and spring, use the chart at right to fine tune your NTC3 settings.

Amount the diff bolt is turned out from tight position (counter clockwise)

	-1/8	-1/4	-3/8	-1/2	-5/8	-3/4
Result	Diff Tighter ←-----→ Diff Looser					
FRONT DIFF	Less Steering ←-----→ More Steering					
REAR DIFF	More Steering ←-----→ Less Steering					

CAUTION: Do not turn the diff bolt out more than 3/4 of a turn.

step 5

- 1 Place one #2293 outdrive shim on both the long and short outdrives.
- 2 Place one #3976 bearing over each outdrive.



BAG C

REMOVE THESE PARTS FOR: Step 6

3920, qty 1	2293, qty 3	6299, qty 1	3977, qty 2	3903, qty 1	2270, qty 1	6920, qty 1	2291, qty 2
front input shaft	input shaft shim	small E-clip	3/16 x 3/8 bearing, rubber sealed	drive pinion	drive cup	4-40 x 3/16 screw	dowel pin

TOOLS USED

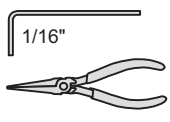

step 6

! Trim any burrs from this edge of the drive pinion with a hobby knife.

FRONT INPUT SHAFT ASSEMBLY

- 1 Install and center the #2291 dowel pin into the #3920 front input shaft.
- 2 Trim burrs from the drive pinion edge where shown above. Slide the #3903 drive pinion onto the input shaft. **Make sure the dowel pin aligns perfectly with the slot in the pinion.**
- 3 Add the #6299 small E-clip.
- 4 Slide two #2293 input shaft shims and one #3977 bearing onto the #3920 input shaft.

- 5 Slide the second #3977 bearing onto the input shaft, followed by the third #2293 input shaft shim.
- 6 Install and center the #2291 dowel pin into the input shaft.
- 7 Slide a #2270 drive cup onto the end of the input shaft.
- 8 Tighten it down with one #6920 screw.



front input shaft assembled
PLEASE COMPARE YOUR ASSEMBLY CAREFULLY

BAG C

TOOLS USED

REMOVE THESE PARTS FOR: Steps 7-8



2267, qty 1 gear adapter



3919, qty 1 C-clip



2661, qty 1 large E-clip



2266, qty 1 54T spur gear

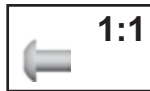

6920, qty 3 4-40 x 3/16 screw



2273, qty 1 single speed input shaft



3903, qty 1 drive pinion



3977, qty 1 3/16 x 3/8 bearing, rubber sealed



2293, qty 2 input shaft shim



2291, qty 2 dowel pin



6299, qty 1 small E-clip

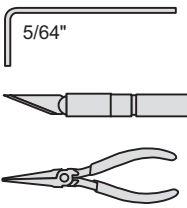

step 7

- 1 Attach a #2266 54 tooth spur gear onto the #2267 gear adapter with three #6920 screws.
- 2 Install and center a #2291 dowel pin in the #2273 single speed input shaft.
- 3 Slide on the gear adapter assembly. Add a #2261 large E-clip to secure it.
- 4 Attach the #3919 C-clip to the input shaft.

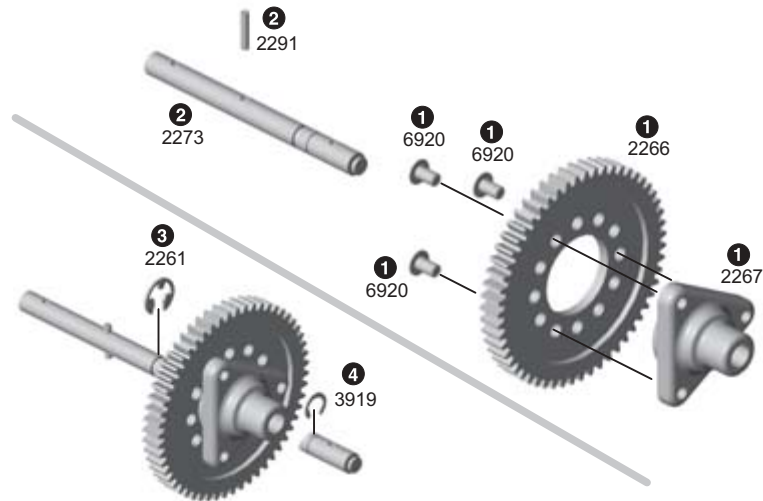

step 8

- 1 Slide one #3977 bearing and two #2293 input shaft shims onto the input shaft.
- 2 Install and center a #2291 dowel pin into the input shaft.
- 3 Slide on the #3903 drive pinion onto the end of the input shaft.
- 4 Add a #6299 E-clip to secure it.

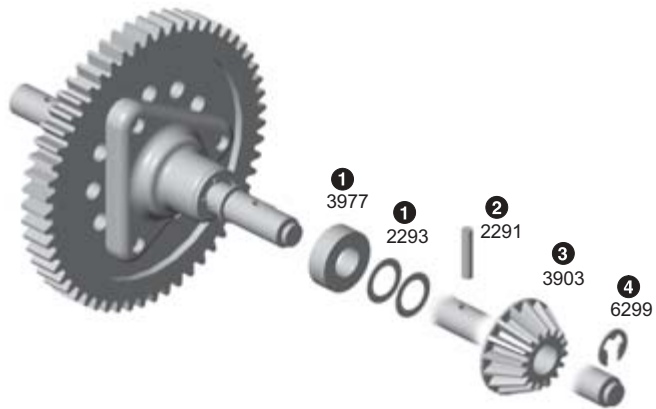

BAG C

REMOVE THESE PARTS FOR: Step 9

1:1



3977, qty 1
3/16 x 3/8 bearing,
rubber sealed

1:1



2293, qty 1
input shaft shim

1:1



2291, qty 1
dowel pin

1:1



6920, qty 1
4-40 x 3/16 screw

1:1



5407, qty 1
red O-ring

1:1



2270, qty 1
drive cup

1:1



2281, qty 1
brake disc

TOOLS USED

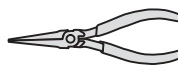

step 9

- Slide one #3977 bearing onto the opposite end of the input shaft, followed by the third #2293 input shaft shim.
- Install and center a #2291 dowel pin into the input shaft.
- Clean the #2281 brake disc with motor cleaner. Place #2281 brake disc onto the #2270 drive cup. Slide the drive cup with the brake disc onto the input shaft. Tighten it down with one #6920 screw.
- Slide one #5407 O-ring into the drive cup.

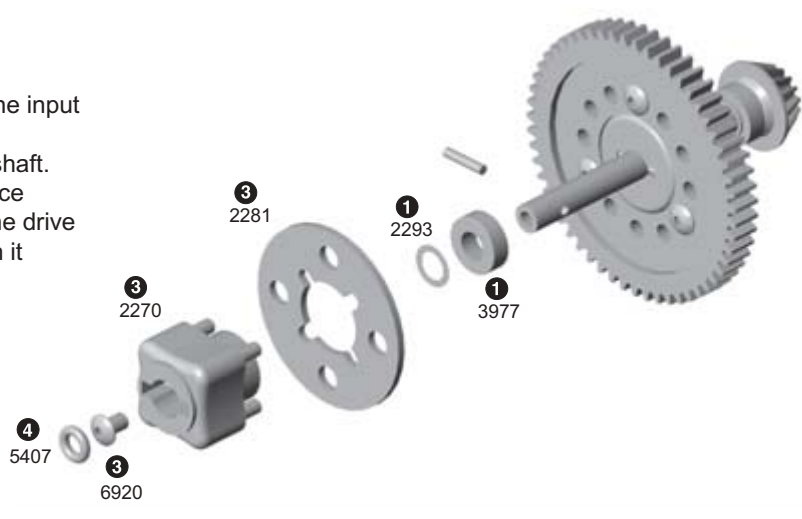

BAG C

REMOVE THESE PARTS FOR: Steps 10-15

1:1



6863, qty 1
flanged bushing
3/16 x 5/16

1:1



2276, qty 1
brake cam

1:1



2274, qty 1
brake bracket

1:1



2277, qty 1
flanged bushing
1/8 x 1/4

1:1



2661, qty 1
large E-clip

1:1



2280, qty 1
brake cam
lever wire

1:1



6920, qty 1
4-40 x 3/16 screw

TOOLS USED

1/16", 3/32"

1:1



6292, qty 4
4-40 x 3/8 screw

1:1

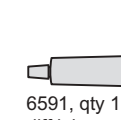

6591, qty 1
diff lube

1:1

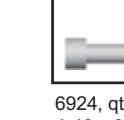

6924, qty 6
4-40 x 3/8 screw

1:1

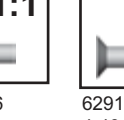

6291, qty 2
4-40 X 1/4 screw

1:1



2278, qty 2
brake pad

1:1



2269, qty 1
center bulkhead

1:1



6922, qty 2
4-40 x 1/2 screw

2368, qty pr transmission cases, top & bottom

step 10

- Slide #6863 bushing onto the end of the #2276 brake cam.
- Angle the brake cam with bushing and slide it through the large hole of the #2274 brake bracket. Press #6863 bushing into the brake cam while still on the brake cam.

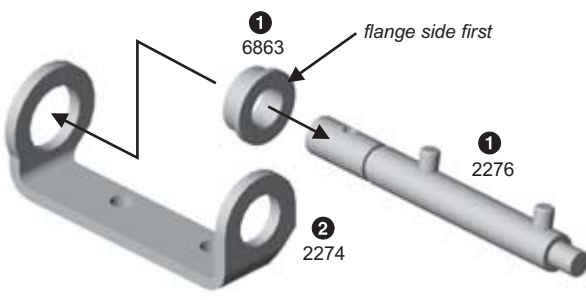

step 11

- Place #2277 bushing in between the brake cam and brake bracket and press it into the brake bracket.
- Slide the brake cam into the bushing.
- Add #2661 large E-clip.

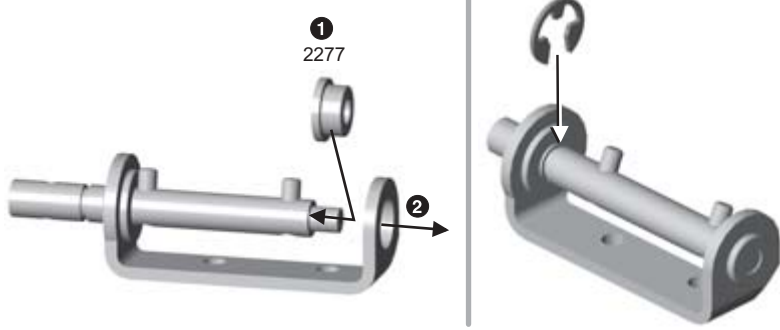

step 12

- Slide #2280 brake cam lever wire into the brake cam. Make sure that the wire is angled as shown at right. Slide the wire through the side of the cam so the brake cam pins are facing up.
- Secure with #6920 screw.

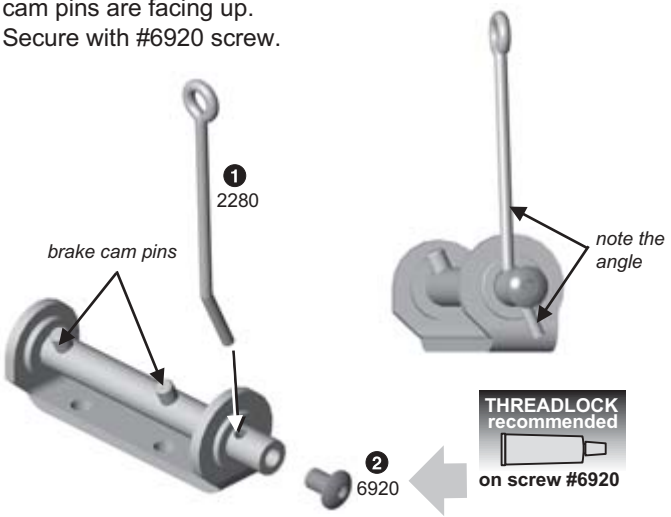

step 13

- Attach #2368 lower transmission case to the chassis with four #6292 screws.

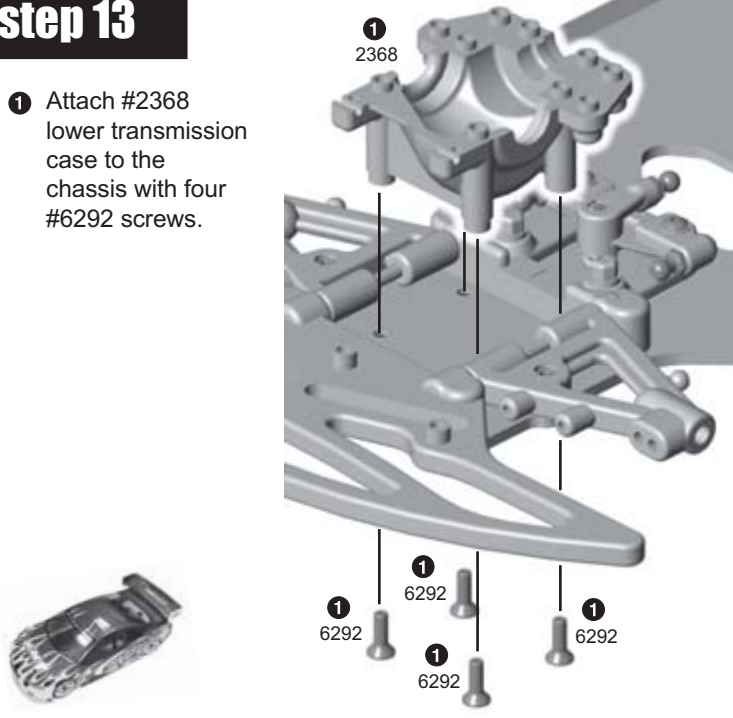

step 14

- Place the front diff assembly and front input shaft assembly into the lower transmission case.
- Squeeze four beads of #6591 diff lube equally spaced apart to the front side of the ring gear and pinion gear.
- Attach the #2368 upper transmission case to the lower case with six #6924 screws. **Do not overtighten.**

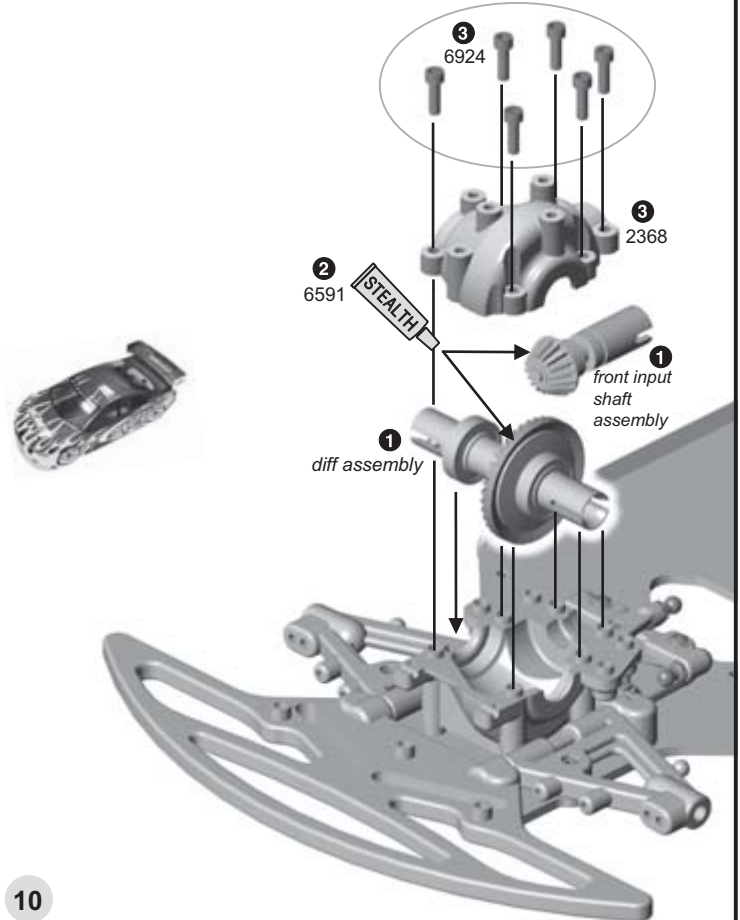

step 15

- Attach the brake cam assembly to the chassis with two #6291 screws.
- Slide one #2278 brake pad (steel side facing bulkhead) onto the #2269 center bulkhead. Slide the second #2278 brake pad (steel side facing away from bulkhead) onto the #2269 center bulkhead.
- Attach center bulkhead to the chassis with two #6922 screws.

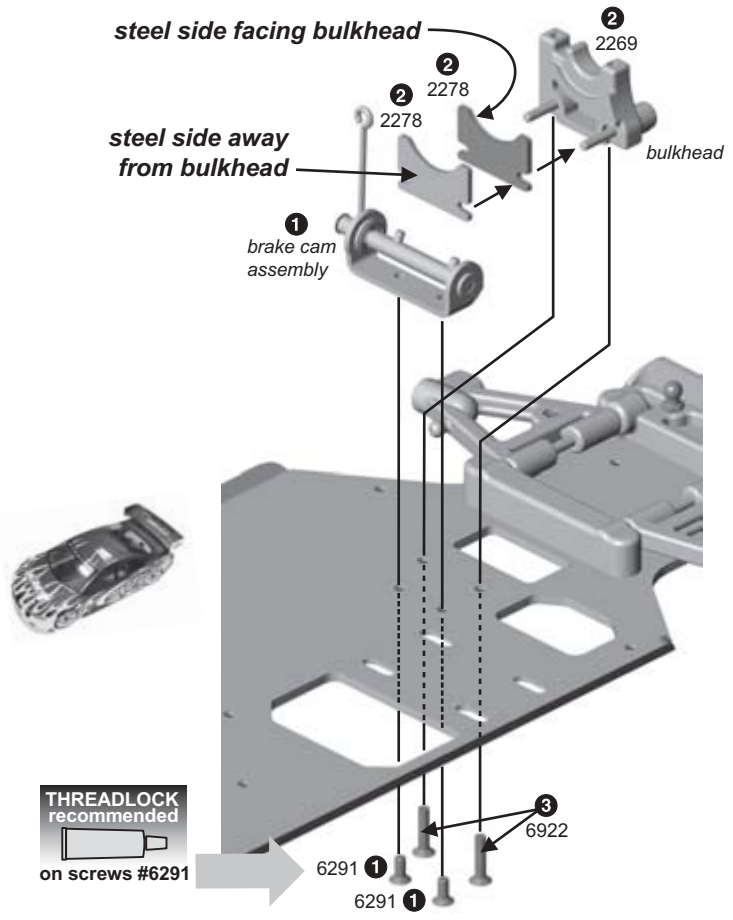

BAG C

REMOVE THESE PARTS FOR: Steps 16-18



2368, qty 1
lower transmission case



6292, qty 4
4-40 x 3/8 screw



2262, qty 1
main drive shaft

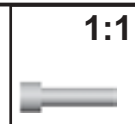

6591, qty 1
Stealth lube



6924, qty 8
4-40 x 3/8 screw

TOOLS USED

1/16", 3/32"

2269, qty 1
bearing cap

step 16

- 1 Attach #2368 lower transmission case to the chassis with four #6292 screws.

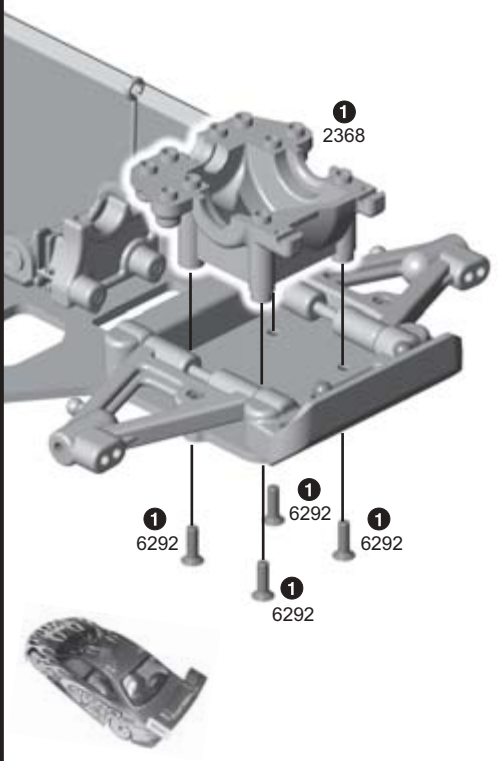

step 17

- 1 Place the diff assembly into the lower transmission case.
- 2 Place one end of the #2262 drive shaft into the rear input shaft assembly. The shaft may be a slightly snug fit in the cup. Install the opposite end into the front drive cup.
- 3 Set the input shaft into place, making sure the brake disc is placed in between the brake pads.
- 4 Squeeze four beads of #6591 diff lube equally spaced apart to the front side of the ring gear and pinion gear.
- 5 Attach #2368 upper transmission case to the lower transmission case with six #6924 screws.

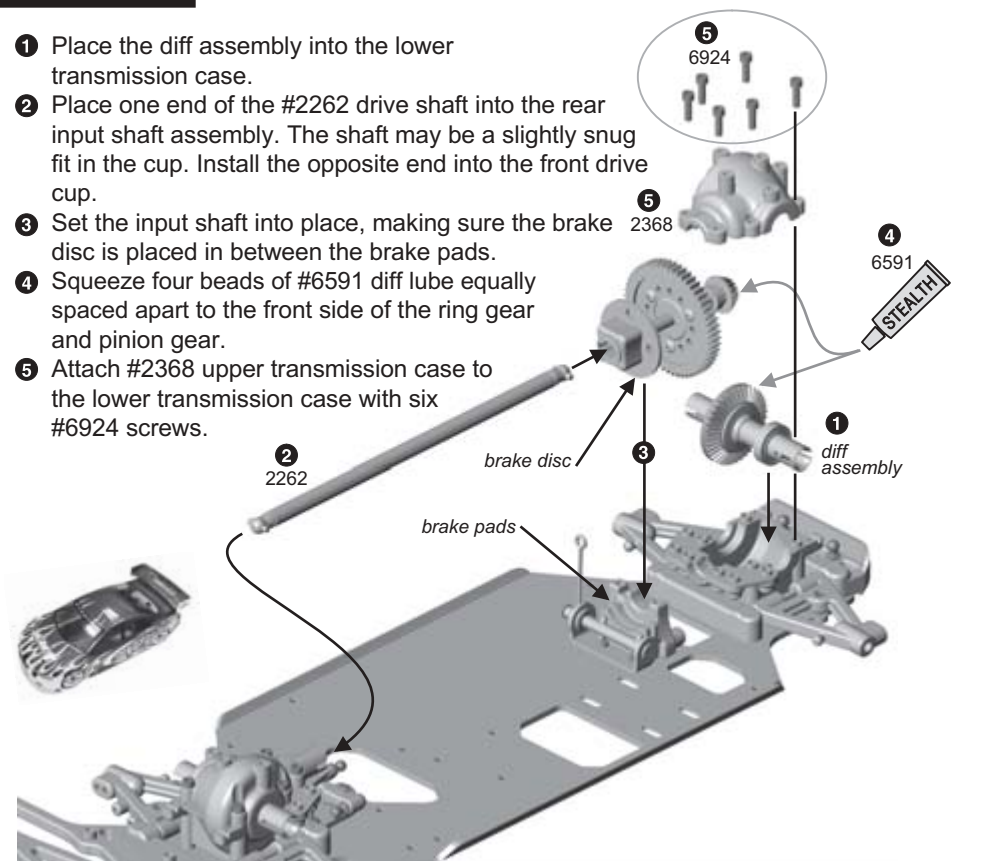

step 18

- 1 Align the #2269 bearing cap over the bearing and attach with two #6924 screws. Do not overtighten.

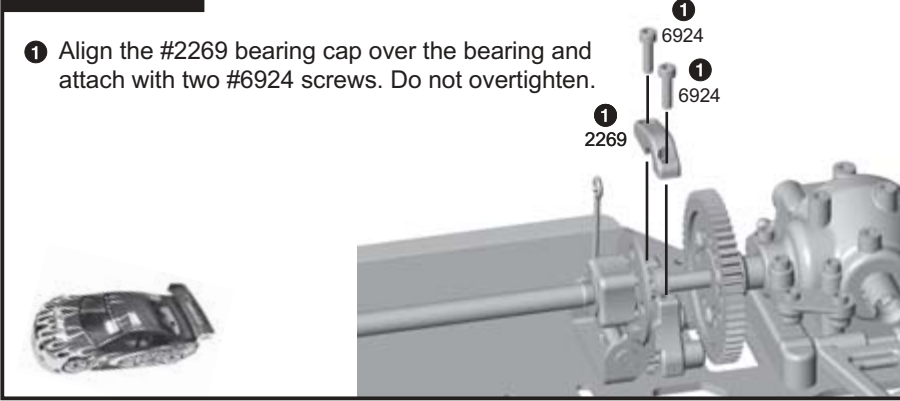

BAG D

TOOLS USED

1/16", 3/32"

1:1

1:1

1:1

1:1

1:1

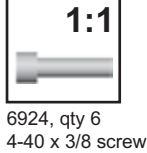
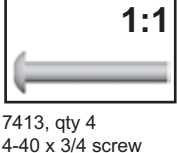
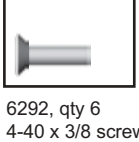
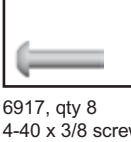

REMOVE THESE PARTS FOR: Steps 1-5

step 1

1 Attach #2254 right & left front chassis braces to the transmission case with #6917 screws and to the chassis with #6292 screws.

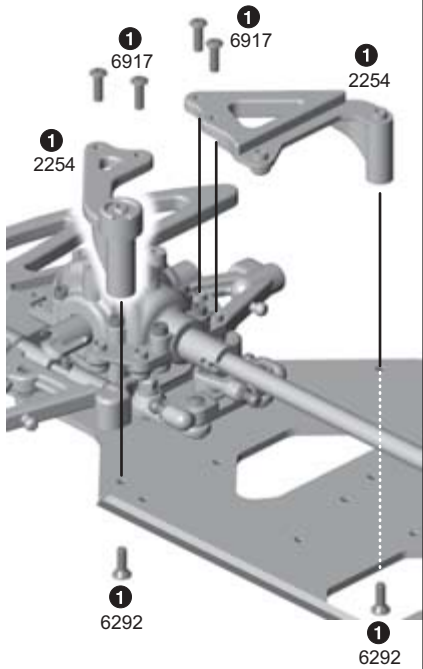

step 2

1 Attach #2254 right & left rear chassis braces to the transmission case with #6917 screws and to the chassis with #6292 screws.

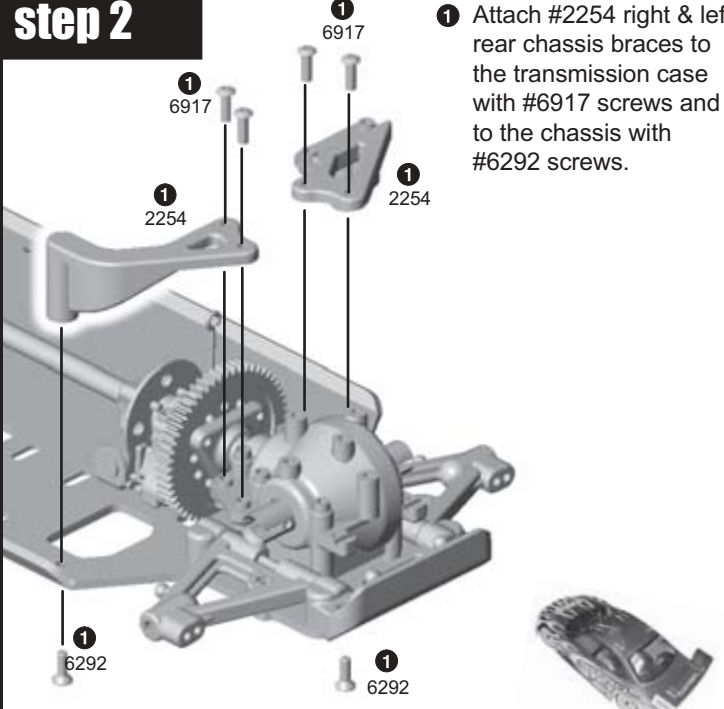

step 3

1 Push the #6292 screws through the bottom of the chassis and place a #5407 O-ring on each screw.
2 Place #2260 handle onto the screws and tighten the screws to compress the O-rings.

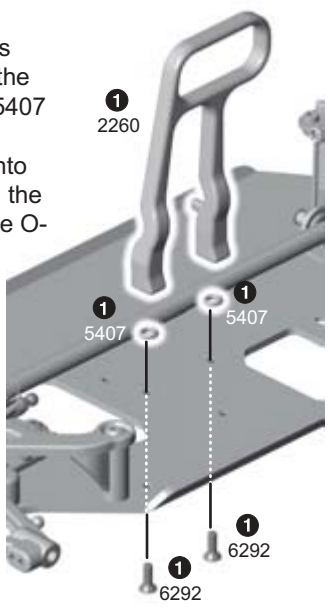

step 4

1 Install the #7413 screws through the middle hole on the #2250 front / rear tower.
2 Then thread on the #7260 nuts and tighten.
3 Repeat step for second tower.

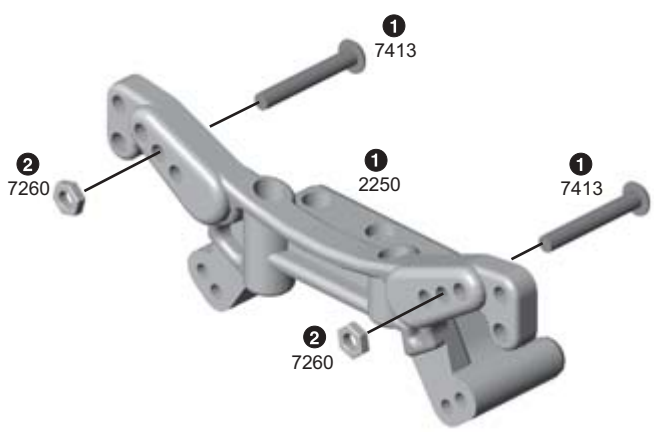

step 5

- Attach one shock tower assembly to the front transmission case and the second one to the rear transmission case with three #6924 screws.

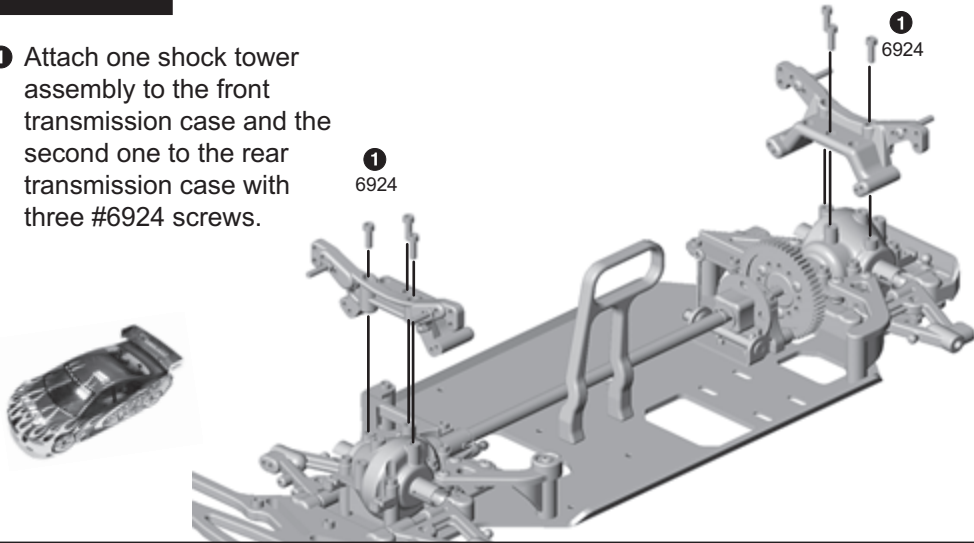

TOOLS USED

- .050" (hook)
- 3/16", 1.4" (Allen wrench)

BAG E

REMOVE THESE PARTS FOR: Step 1

BLACK GREASE 6588, qty 1 black grease	2402, qty 4 Unini axle	7381, qty 4 coupling	7381, qty 4 cross pin	THREADLOCK 7381, qty 1 threadlock	7381, qty 4 set screw	2402, qty 4 Unini dogbone		
3977, qty 8 3/16 x 3/8 bearing, rubber sealed	2247, qty 2 pr steering/hub carrier left and right	3965, qty 4 bearing spacer	7368, qty 4 thin spacer	7369, qty 4 roll pin	6273, qty 2 ball end (silver)	7260, qty 2 4-40 plain nut	2257, qty 2 rear toe ball end (gold)	2257, qty 2 6-32 plain nut

step 1

UNINI DRIVE ASSEMBLY

- Spread some Associated #6588 black grease inside the #2402 Unini dogbone where shown, then on the #7381 coupling and insert the coupling into the axle.
- Slide the #2402 Unini axle into the #2402 Unini dogbone, aligning the cross pin holes.
- Insert the #7381 cross pin, making sure it is evenly spaced on both sides of the axle.
- Add a small drop of thread lock to the #7381 set screw. Angle and turn the axle so the set screw can be screwed in with the Allen wrench.
- Repeat steps 1-4 for the three remaining Unini dogbone assemblies.

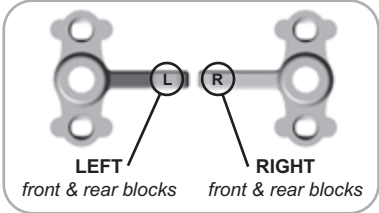

STEERING / HUB CARRIER ASSEMBLY

- Slide one #3977 bearing onto the axle. Slide the axle assembly into the back of the #2247 steering/hub carrier
- Slide in a #3965 bearing spacer
- Install the second #3977 bearing into the steering / hub carrier, followed by one #7368 thin spacer.
- Insert the #7369 roll pin into the axle.
- Repeat steps 6-9 for the three remaining steering / hub carriers.
- FRONT:** Thread a #6273 ball end into the bottom of one right and one left steering / hub carriers for the front. Add a #7260 plain nut.
- REAR:** Thread a #2257 rear toe ball end into the bottom of one right and one left steering / hub carriers for the rear. Add a #2257 large plain nut.

FRONT
Use this hole in the front steering/hub carriers

REAR
Use this hole in the rear steering/hub carriers

BAG E

TOOLS USED

REMOVE THESE PARTS FOR: Steps 2-5



2246, qty 8
pivot ball



2249, qty 8
socket cap



6924, qty 16
4-40 x 3/8 screw

1:1

Compare the front and rear upper arms. Opening A (front upper arm) is wider than opening B (rear upper arm)

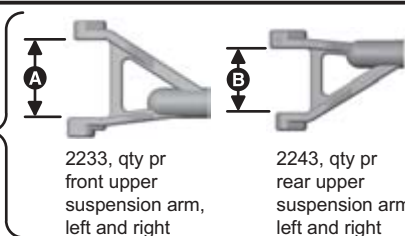

2233, qty pr front upper suspension arm, left and right

2243, qty pr rear upper suspension arm, left and right

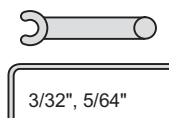

3/32", 5/64"

step 2

- 1 Insert one #2246 pivot ball into the upper socket and one into the lower socket of the steering / hub carrier assemblies.
- 2 Insert the #2249 socket caps and secure them down with #6924 screws. Tighten the socket cap screws so that the pivot ball moves freely without any binding or excess play.
- 3 Repeat for the remaining three steering / hub carriers.

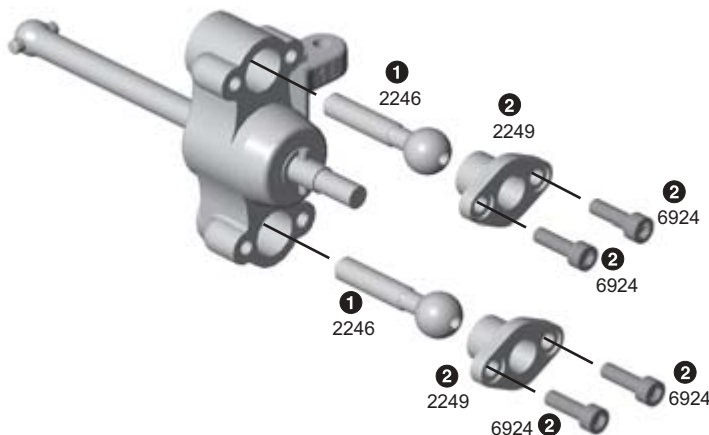

step 3

FRONT UPPER SUSPENSION ARM

- 1 Add a small amount of #6588 black grease to the end of the threads on the pivot ball.
- 2 Use your 5/64" Allen wrench to screw the pivot ball into the #2233 left front upper suspension arm. Do not thread pivot ball all the way in.
- 3 Repeat for the right front.

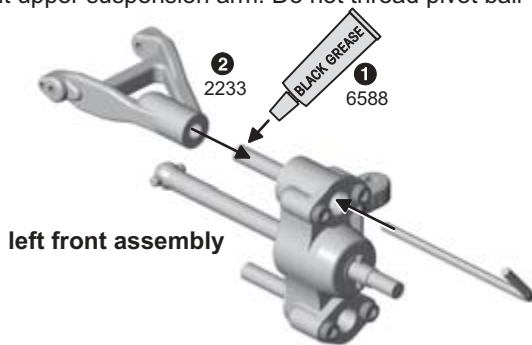

step 4

REAR UPPER SUSPENSION ARM

- 1 Add a small amount of #6588 black grease to the end of the threads on the pivot ball.
- 2 Use your 5/64" Allen wrench to screw the pivot ball into the #2243 left rear upper suspension arm. Do not thread pivot ball all the way in.
- 3 Repeat for the right rear.

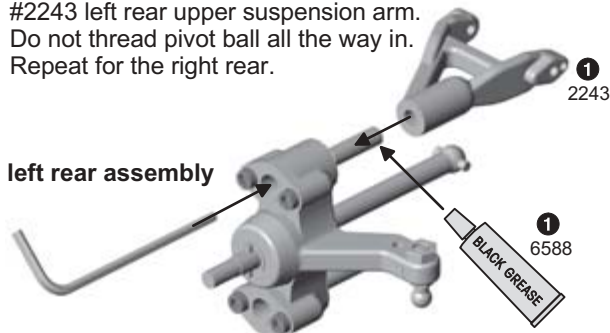

step 5

- 1 Add a small amount of #6588 black grease to the end of the threads on the pivot ball.
- 2 Use your Allen wrench to screw the pivot ball into the #2233 front lower suspension arm.
- 3 Slide your supplied track width gauge in between the steering / hub carrier assembly and the lower arm.
- 4 Use your 5/64" Allen wrench to tighten the pivot ball until the gauge is sandwiched in between the two. Turn the pivot ball counter clockwise until the gauge can be removed.
- 5 Repeat for the lower suspension arms for the right front, left rear, and the right rear.

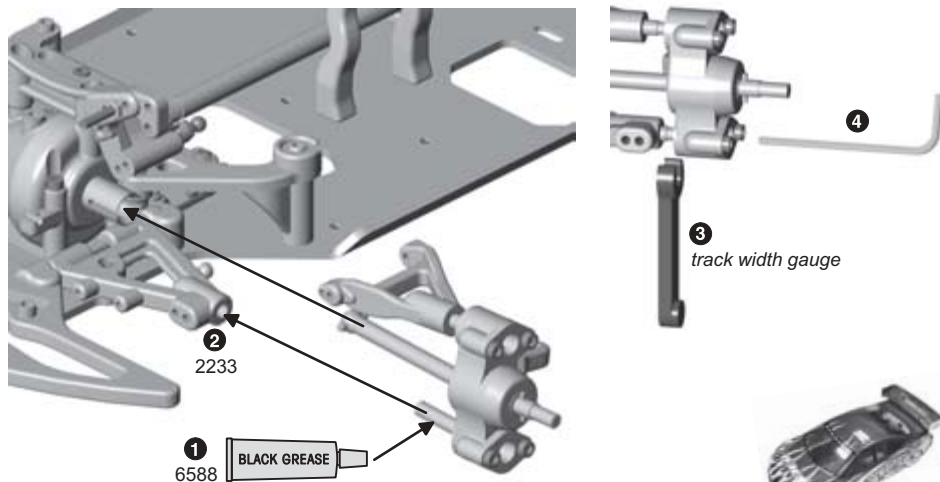

BAG E

1:1

1:1

1:1

REMOVE THESE PARTS FOR: Steps 6-8



9146, qty 4
2/56 x 3/16 screw



6274, qty 4
ball cup,
black



2251, qty 4
ball cup,
gray

2235, qty 2
front upper hinge pin



1:1

2235, qty 2
rear upper hinge pin



1:1

TOOLS USED

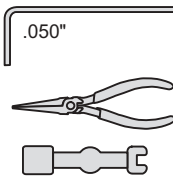

2239, qty 4
caster clip

6264, qty 2
steering link
turnbuckle



1:1

2253, qty 2
rear toe
turnbuckle



1:1

step 6

- Line up the #2233 front upper suspension arm with the inner hole on the shock tower, making sure the Unini dogbone is in the slots of the outride. Push a #2235 hinge pin into the arm and the shock tower.
- Fasten #9146 screw into the upper arm. The screw holds in the hinge pin.
- Clip in the two #2239 caster clips. Place one on each side of the tower. This sets your caster at 9 degrees.
- Repeat step 6 for the right front.

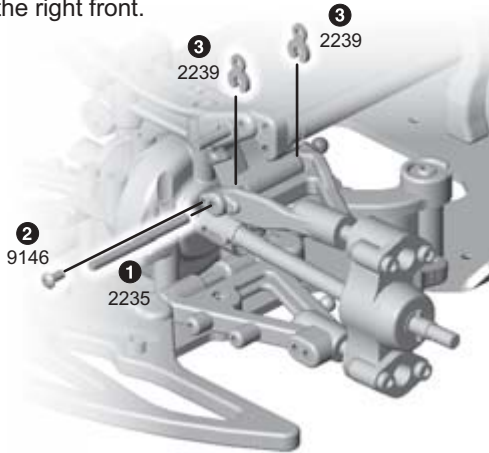

step 7

- Line up the #2243 rear upper suspension arm with the inner hole on the shock tower, making sure the Unini dogbone is in the slots of the outrides. Push #2235 hinge pin into the arm and the tower.
- Fasten #9146 screw into the upper arm.
- Repeat step 7 for the right rear.

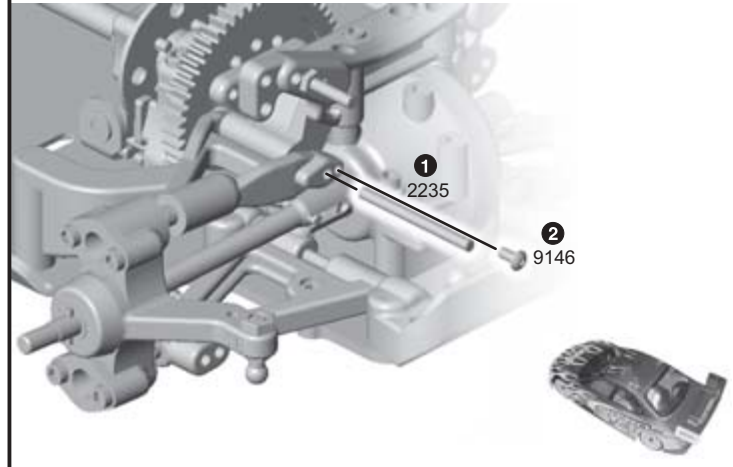

step 8

- Twist the #6274 ball cups onto the #6264 turnbuckle until you get the dimension shown (steering turnbuckle). Assemble both turnbuckles.
- Twist the #2251 gray ball cups onto the #2253 rear toe turnbuckle until you get the dimension shown (rear toe turnbuckle). Assemble both turnbuckles. This results in 2° rear toe.
- Snap all four turnbuckles into place where shown.

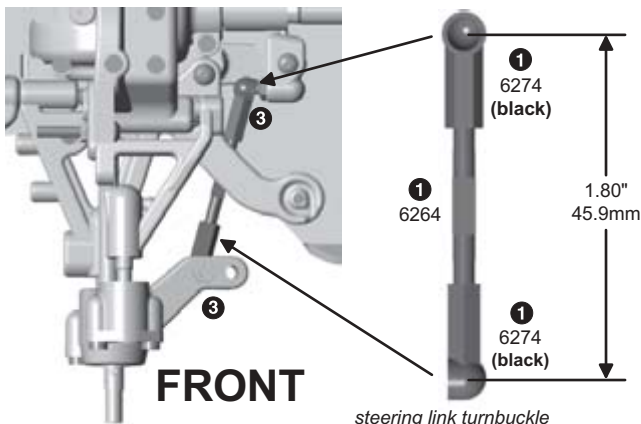

FRONT

steering link turnbuckle

To screw ball cup onto turnbuckle:

- Grip middle of turnbuckle with needlenose pliers.
- Thread on ball cup by hand at first, then use turnbuckle tool to finish.
- Squeeze turnbuckle onto ball end with needlenose pliers.

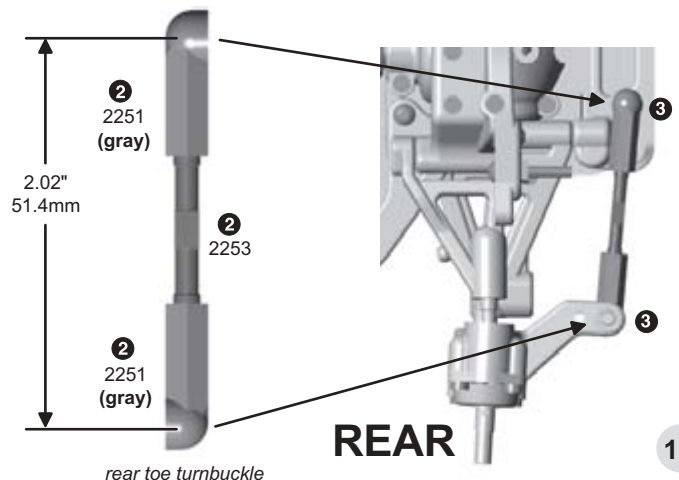

REAR

rear toe turnbuckle

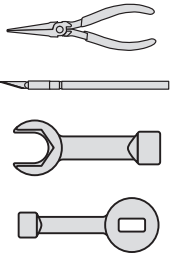

REMOVE THESE PARTS FOR: Steps 1-4

1:1
5407, qty 8 red O-ring

1:1
6299, qty 8 E-clip

1:1
8456, qty 4 VC foam

1:1
6428, qty 4 shock cap

1:1
7217, qty 4 shock pivot ball

1:1
7217, qty 4 shock eyelet

1:1
6469, qty 4 large O-ring

8844, qty 4 shock shaft, .35 stroke

8458, qty 4 composite macro shock body

1:1
6465, qty 2 shock piston #2 rear

1:1
6465, qty 2 shock piston #3 front

8456, qty 4 VC bobbin

5423, qty 1 40 wt silicone oil

step 1

TRIM SHOCK PISTON

- 1 Burrs on the #6465 shock piston interfere with smooth shock action within the shock body. To remove from tree without creating burrs, twist up, not down. Remove two #2 and two #3 shock pistons.
- 2 Remove remaining burrs carefully with a hobby knife.

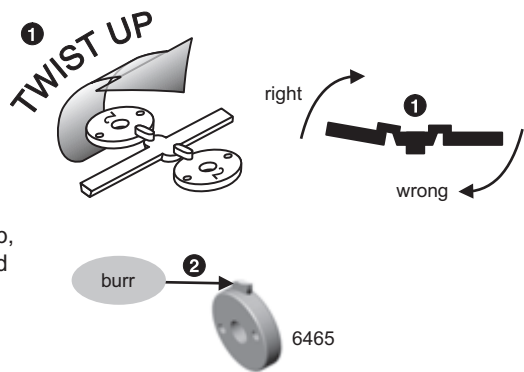

step 2

VC FOAM AND BOBBIN

- 1 Soak the #8456 VC foam with #5423 40wt shock oil and install it onto the #8456 VC bobbin.

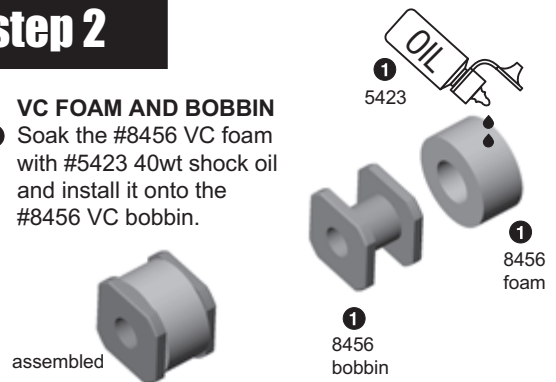

step 3

INTERNAL SHOCK ASSEMBLY





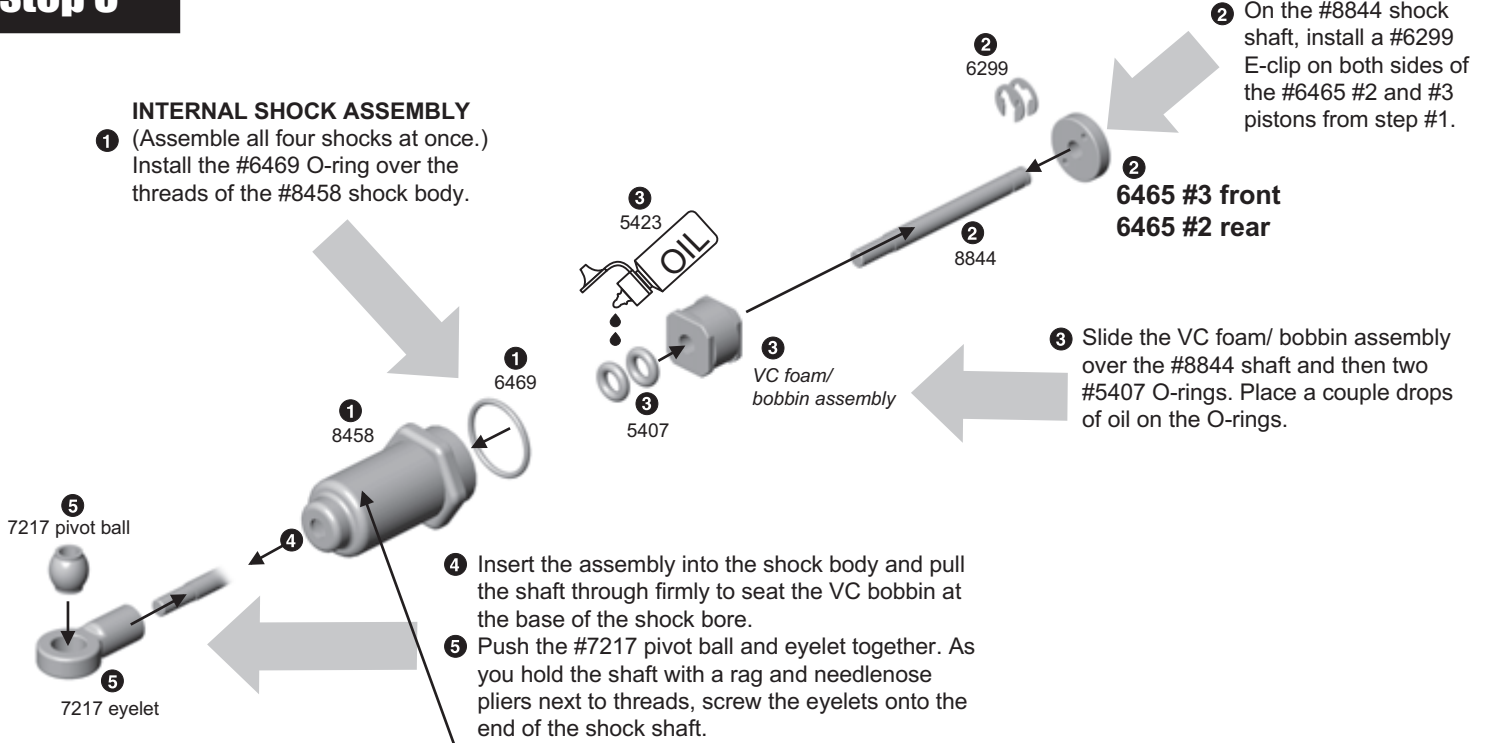



- 1 (Assemble all four shocks at once.) Install the #6469 O-ring over the threads of the #8458 shock body.

- 2 On the #8844 shock shaft, install a #6299 E-clip on both sides of the #6465 #2 and #3 pistons from step #1.









TIP: Use a permanent marker to mark your shocks with an F and R to designate front and rear.

Step 4

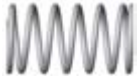

- Holding the shock upright, fill with oil to the top of the body. 
 - Slowly move the shaft up and down several times to allow air bubbles to escape to the top. 
 - Refill with oil to the top of the body. 
 - Push the shaft up until the piston is level with the top of the body. The oil will bulge up above the shock body. 
 - Fill The #6428 shock cap about halfway with oil and install onto the body. Try to retain as much oil as possible during assembly. The shaft will extend out as you tighten the cap down. 
-
- Move the shock shaft in and out a few times and then push it all the way in. It should be easy to push the shaft in until the eyelet hits the body. 
 - Then the shaft should push itself out to its full length very slowly. 
 - If the shock does not push out this far there is not enough oil in it. Add a drop of oil and try steps 6-7 again. 
 - If the shock rebounds too fast, or you cannot push the shaft in until the eyelet hits the body, there is too much oil. Loosen the cap about a full turn and pump out a small amount of oil by pushing the shaft in. Retighten the cap and try steps 6-7 again. Too much oil in the shock will result in leakage. 

BAG F

REMOVE THESE PARTS FOR: Steps 5-7

<p>1:1</p>  <p>6925, qty 4 4-40 x 1/2 screw</p>	<p>1:1</p>  <p>6472, qty 4 shock nut, small</p>	 <p>6473, qty 4 shock bushing</p>	 <p>6475, qty 4 spring cup</p>	 <p>3946, qty 2 spring, copper, front</p>	 <p>3944, qty 2 spring, gold, rear</p>
 <p>8846, qty 6 preload spacers, 1/4", .030"</p>	 <p>6475, qty 4 spring retainer</p>				

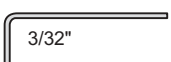
TOOLS USED

-  3/32"
-  3/16"

Step 5

- Add #8846 preload spacers to the shock bodies: In the **front**: one 1/4" spacer. In the **rear**: one each 1/4" and .030" spacers.
- Slide the #6475 spring retainer onto the body facing the direction shown.
- Slide the #3946 copper springs on the front shocks, and #3944 gold springs on the rear shocks.
- Compress the spring to add the #6475 spring cup to all four shocks.

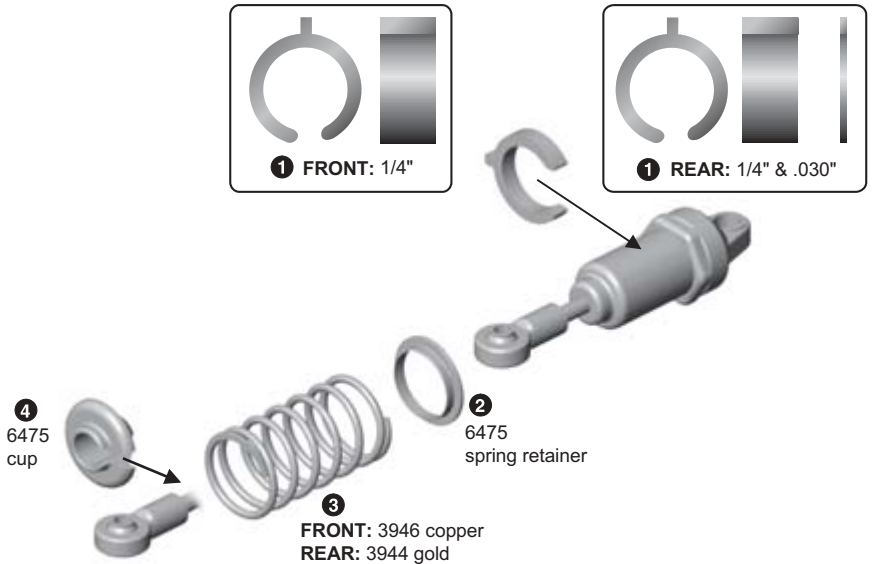

step 6

FRONT SHOCK MOUNTING

- 1 Add the #6473 shock bushing to the front shock tower screw shown.
- 2 Push the shock cap over the bushing and add a #6472 shock nut. **Do not over tighten or the shock will bind.**
- 3 Fasten the shock eyelet into the outer hole of the arm with a #6925 screw.
- 4 Repeat steps for second front shock.

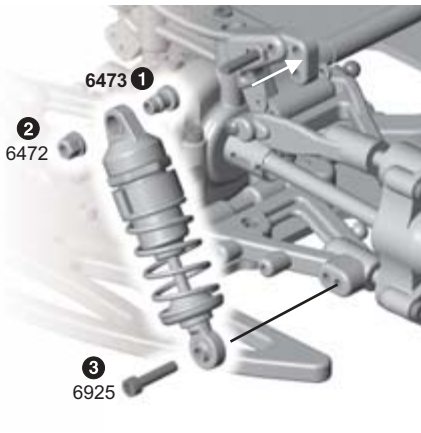

step 7

REAR SHOCK MOUNTING

- 1 Add the #6473 shock bushing to the rear shock tower screw shown.
- 2 Push the shock cap over the bushing and add #6472 shock nut. **Do not over tighten or the shock will bind.**
- 3 Fasten the shock eyelet into the outer hole of the arm with a #6925 screw.
- 4 Repeat steps for second rear shock.

Your front and rear shock preload clips set ride height. For more information on ride height, see page 30.

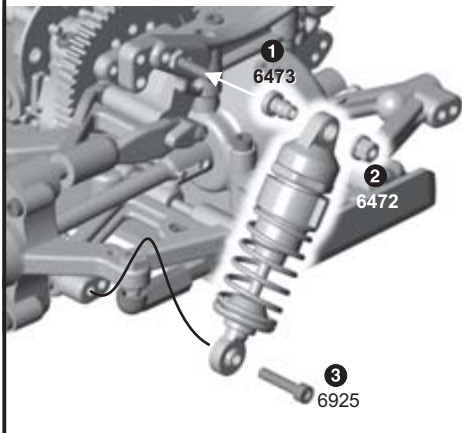

BAG G

REMOVE THESE PARTS FOR:
Step 1



7673, qty 3
4-40 x 5/16 screw



5407, qty 3
red O-ring

1/16"



7721, qty 1
fuel tank

TOOLS USED

step 1

- 1 Push the #7673 screws through the bottom of the chassis and place a #5407 red O-ring on each screw.
- 2 Set the #7721 tank onto the screws and tighten the screws just enough to slightly compress the O-rings so the tank can't move around.

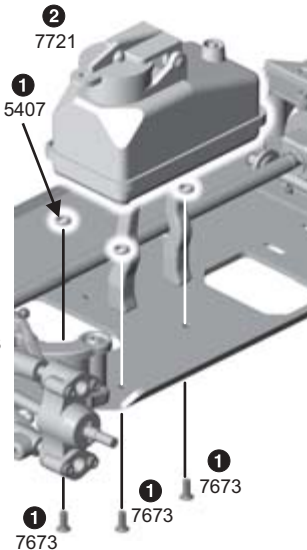

BAG H

REMOVE THESE PARTS FOR:
Steps 1-5



9146, qty 4
2-56 x 3/16 screw



2258, qty 1
receiver box



9180, qty 4
servo horn



3857, qty 1
short special ball end, black



7336, qty 2
servo mount



7336
offset spacer



qty 2 thin (.050")
qty 2 thick (.100")



7337, qty 8
steel washer



6917, qty 8
4-40 x 3/8 screw



2256, qty 1
radio tray



3720, qty 2
wire tie, 8"



3718, qty 1
wire tie, 12"



2326, qty 2
throttle servo spacer
med (.080")



6918, qty 4
4-40 x 1/2 screw



2252, qty 1
battery mount

TOOLS USED

.050", 1/16"

3/16"

step 1

- 1 Insert #2258 receiver box into the #2256 radio tray and secure with four #9146 screws.

CAUTION: The box will fit tight.

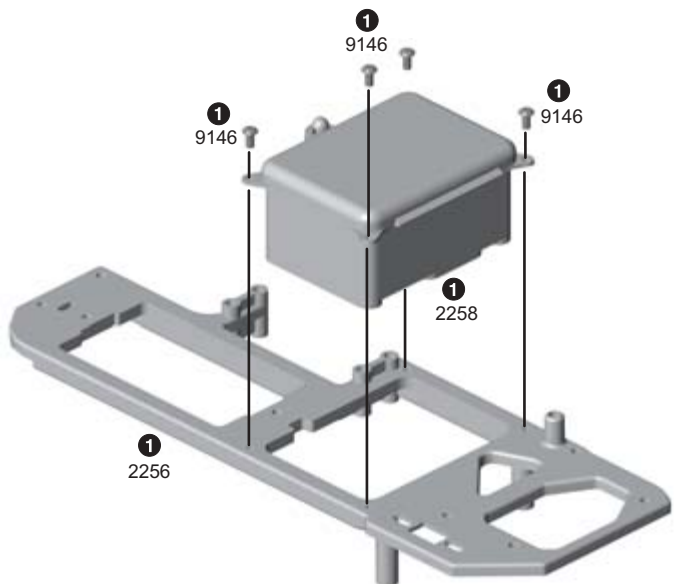

step 2

- 1 Find the appropriate #9180 servo horn for your servo from the chart at right. Install the #3857 short ball end into the servo arm. Fasten the servo arm down with the stock mounting screw that came with your servo. **DO NOT POINT IT STRAIGHT UP!** See below for correct angle.
- 2 Find the appropriate thick or thin #7336 offset spacer for your servo from the chart at right. Attach the spacer if any, in between the #7336 mount and the servo with the #7337 washers and #6917 screws.

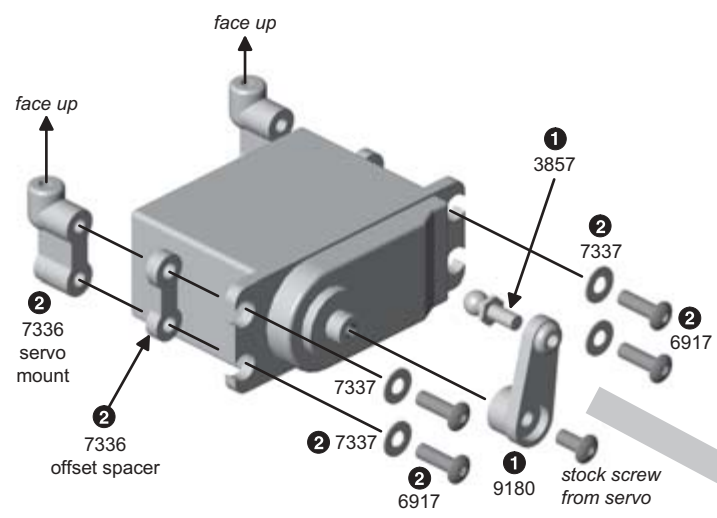

See Radio Adjustments section of manual for more info on correctly setting steering linkage.

STEERING SERVO TYPE	#7336 SPACER	#9180 SERVO ARM
Airtronics 94102	no spacer	A
Airtronics 94738, 94157, 94158, 94257, 94258, 94357, 94358, 94452, 94453, 94751, 94755	thick spacer	A
Hitec HS-5625MG, HS-5645MG, HS-625MG, HS645MG	no spacer	H
Hitec HS-303, HS-300BB, HS-945MG, HS-925MG, HS-5945MG, HS-5925MG, HS-525MG, HS-525BB, HS-425BB, HS-422	thin spacer	H
JR Z4725, Z4750, Z2750, Z8450, Z8550, NES-4750	no spacer	J
JR Z250, Z550	thin spacer	J
Futaba S9204, S9250, S9450, S148	no spacer	F
Futaba S3003, S9202, S9101	thin spacer	F
Futaba S9404	thick spacer	F
KO PS-401, PS-2001, PS-2004, PS-2015, PS-2173, PS-2174, PS-2123, PS-2143, PS-2144	thin spacer	J

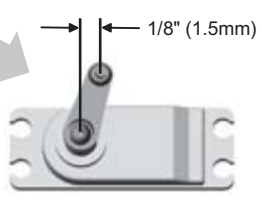

step 3

- 1 Attach the servo to the radio tray with two #6917 screws.

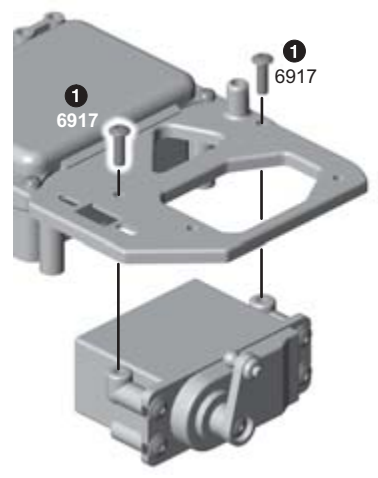

step 4

1 Look at the chart at right to see if a #2326 spacer is needed for your throttle servo. Attach the spacer if any, in between the radio tray and servo with the #7337 washers and #6918 screws.

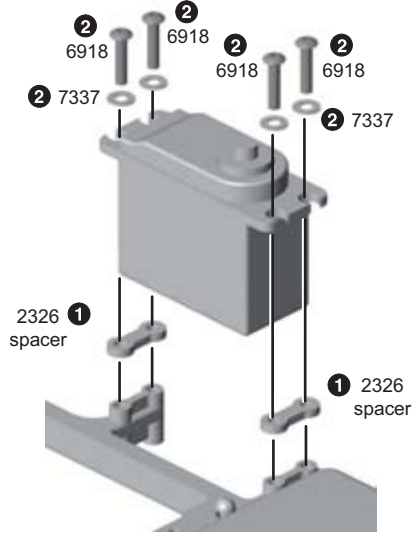

THROTTLE SERVO TYPE	#2326 SPACER	SERVO HORN
Airtronics 94102	no spacer	A
Airtronics 94738, 94157, 94158, 94257, 94258, 94357, 94358, 94452, 94453, 94751, 94755	spacer	A
Hitec HS-5625MG, HS-5645MG, HS-625MG, HS645MG HS-303, HS-300BB, HS-945MG, HS-925MG, HS-5945MG, HS-5925MG, HS-525MG, HS-525BB, HS-425BB, HS-422	no spacer	H
JR Z4725, Z4750, Z2750, Z8450, Z8550, NES-4750	no spacer	A
JR Z250, Z550	spacer	A
Futaba S9204, S9250, S9450, S148, S3003, S9202, S9101	no spacer	F
Futaba S9404	spacer	F
KO PS-401	spacer	A
KO PS-2001, PS-2004, PS-2015, PS-2173, PS-2174, PS-2123, PS-2143, PS-2144	no spacer	A

step 5

USING A BATTERY HARNESS OR 5 CELL HUMP PACK

- 1 Place your batteries into your stock radio battery harness. Attach your harness to the #2252 battery mount with two #3720 wire ties, making sure the harness wires are facing the receiver box.
- 2 Place the battery harness assembly up into the radio tray and fasten down with #6917 screws.
- 3 Attach the switch to the radio tray with the stock switch screws.

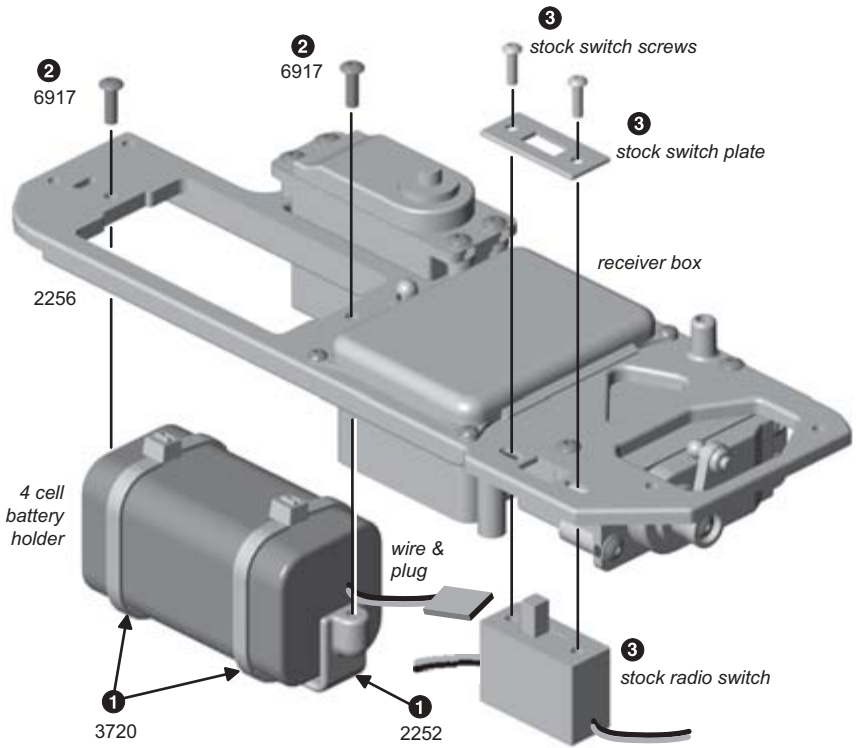

BAG H

TOOLS USED

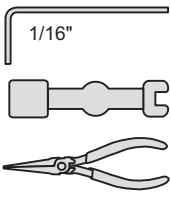

REMOVE THESE PARTS FOR: Steps 6-8

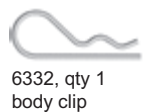

6332, qty 1
body clip

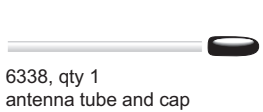

6338, qty 1
antenna tube and cap



6727, qty 1
servo tape



6917, qty 4
4-40 x 3/8 screw



6292, qty 2
4-40 x 3/8 screw



3867, qty 1
steering turnbuckle



6274, qty 2
ball cup

step 6

- 1 Feed your switch wires into location 1.
- 2 Feed your steering servo wire into 2.
- 3 Feed your throttle servo wire into 3.
- 4 Feed your battery wires into 4.

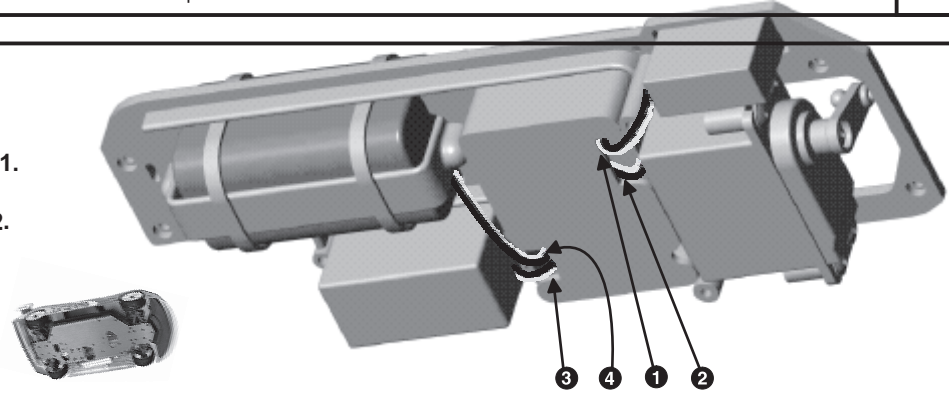

step 7

- 1 Place a piece of #6727 servo tape to the bottom of the receiver.
- 2 Feed the antenna wire through the small hole in the receiver box. Before placing the receiver, move the wire off to the side of the box and then place the receiver into the box.
- 3 Close the box and slip a #6332 body clip in to hold it shut.
- 4 Take your antenna wire and push it through the built in antenna mount in the radio tray.
- 5 Slide the wire through #6338 antenna and push the antenna tube firmly into the mount. Leave some slack at the bottom. Do not cut off excess antenna wire. Cap the other end with the black rubber cap.

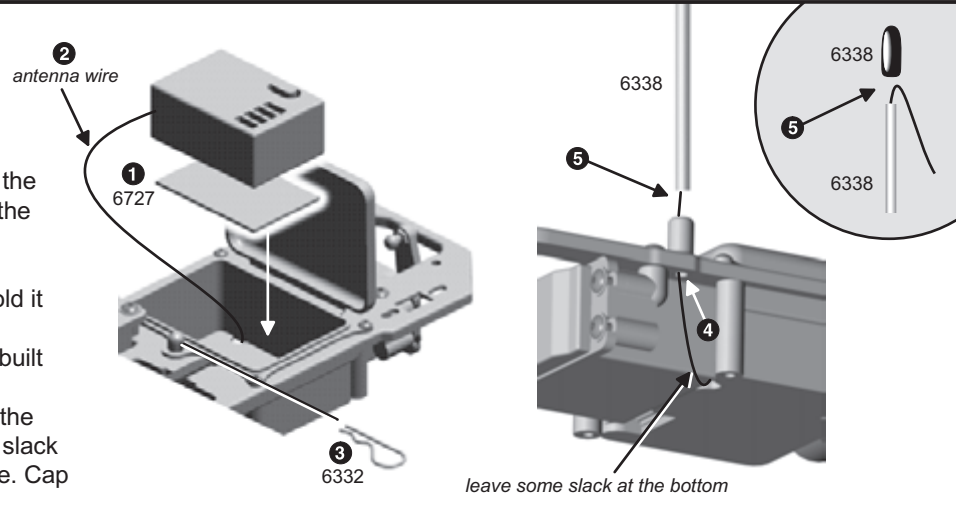

step 8

- 1 Twist #6274 ball cups onto the #3867 turnbuckle until you get the dimension shown.
- 2 Snap one end of the ball end onto the servo arm.
- 3 Place the radio tray temporarily on the chassis. Snap the second end of the turnbuckle onto the ball end of the swing rack. Now place the radio tray into place.
- 4 Before attaching screws make sure the wires from your receiver box are lying flat so they won't get smashed. Attach the radio tray with four #6917 screws for the top and two #6292 screws for the bottom.

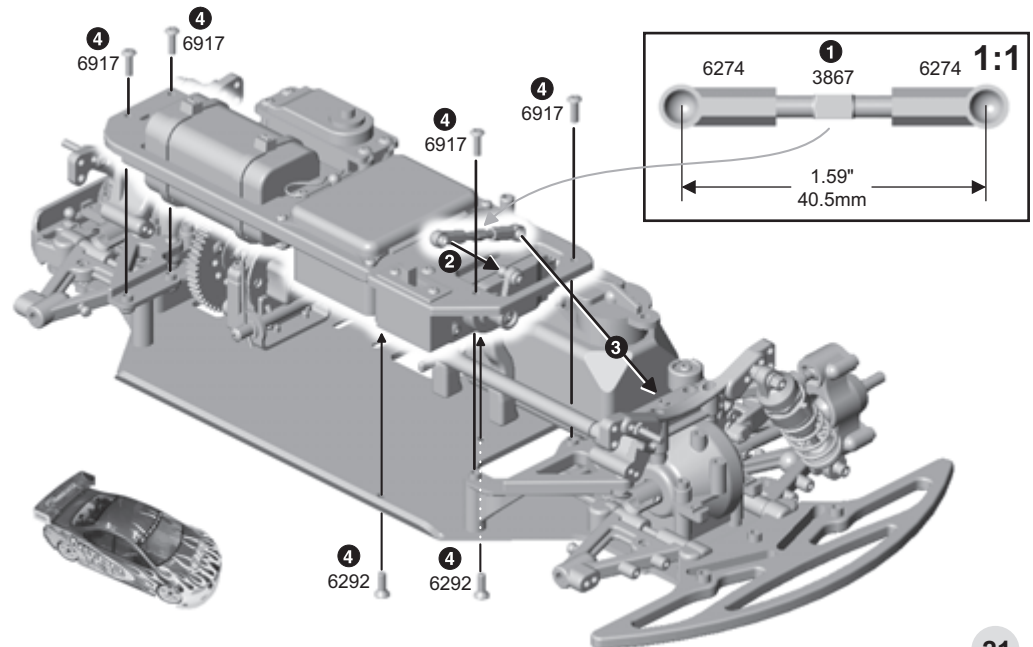

BAG I

1:1

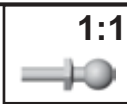

2326, qty 1
2-56 ball end

1:1



2326, qty 1
2-56 plain nut

1:1



7618, qty 1
collet



2313, qty 1
SG clutch nut



2310, qty 2
clutch shoe



2306, qty 2
clutch spring



2340, qty pr
pull start
engine mounts

TOOLS USED

1/16", 5/64", 3/32"

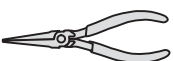

CLUTCH NUT TOOL

REMOVE THESE PARTS FOR: Steps 1-6



2323, qty 1
pull start
flywheel



2320, qty 1
unflanged bearing
5 x 10 x 4



2320, qty 1
flanged bearing
5 x 9 x 3



2321, qty 2
SG shim



3934, qty 1
screw

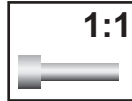

7874, qty 4
4-40 x 7/16 screw



7773, qty 4
screw



2321, qty 1
clutch shim

step 1

1 Attach a #2326 2-56 ball end and a #2326 2-56 plain nut to the lower hole in the throttle arm pivot. If the hole is too small for the ball end, drill it out with a #43 or a 3/32 drill bit. Be careful not to get any metal or plastic shavings into the carb opening.

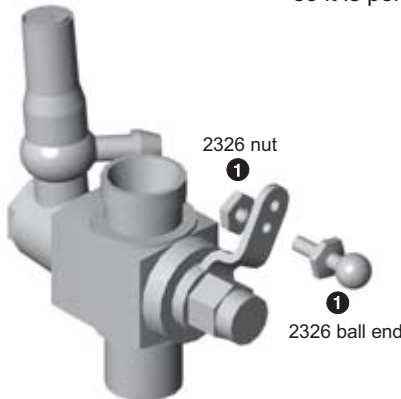

- 2 Use a wrench to loosen your high speed mixture screw. Turn the valve assembly until the fuel fitting is facing the direction shown below, then retighten the valve assembly.
- 3 Loosen the screw or clamp bolt that holds the carburetor in place. Rotate the carb so it is perpendicular to the crank shaft as shown.

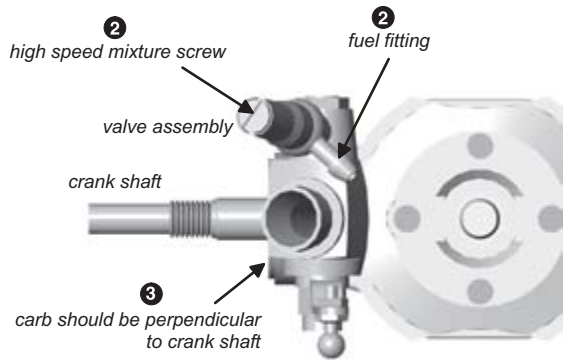

step 2

FLYWHEEL ASSEMBLY

- 1 Slide on #7618 collet
- 2 Install #2322 or #2323 flywheel followed by #2313 SG clutch nut.
- 3 Tighten the clutch nut securely with your supplied wrench, locking the flywheel to the collet.

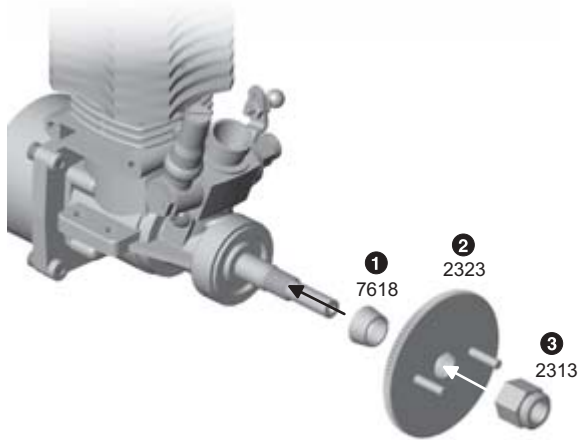

step 3

CLUTCH SHOE ASSEMBLY

- 1 Install your #2310 clutch shoes on the flywheel clutch pins.
- 2 Place the #2306 clutch springs onto the pins on top of the clutch shoes. Use a flat head screwdriver to snap the other side of the spring into the groove of the clutch nut, as shown at far right.

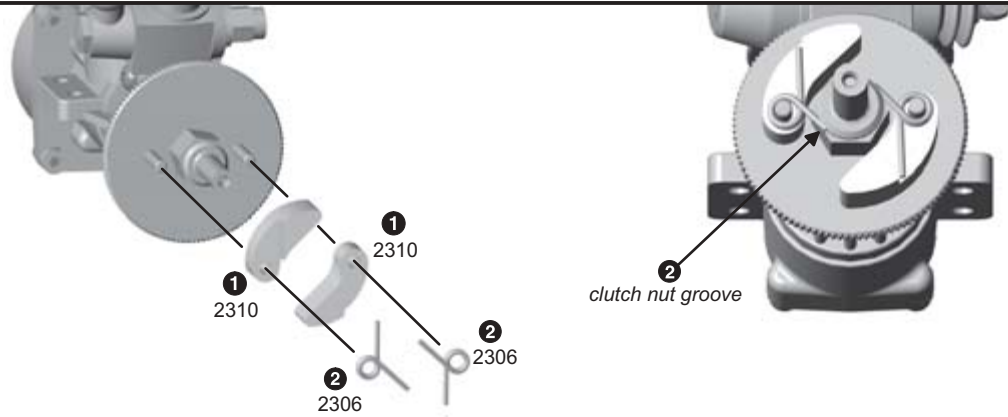

step 4

CLUTCH BELL ASSEMBLY

- 1 Slide onto the engine shaft one #2321 clutch shim followed by #2320 non flanged clutch bearing.
- 2 Slide on the #2316 clutch bell followed by #2320 flanged clutch bearing.
- 3 Slide on two #2321 SG shims onto the #3934 screw, and now tighten down the clutch bell.

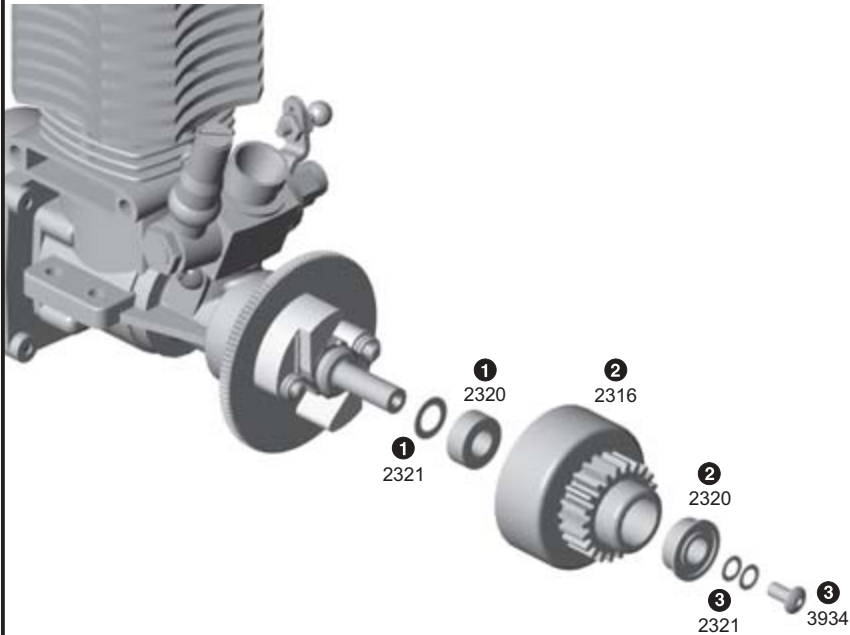

step 5A

- 1 Attach the #2340 engine mounts to your engine with four #7874 screws, sliding one #7562 throttle return spring mount onto the back right screw shown.

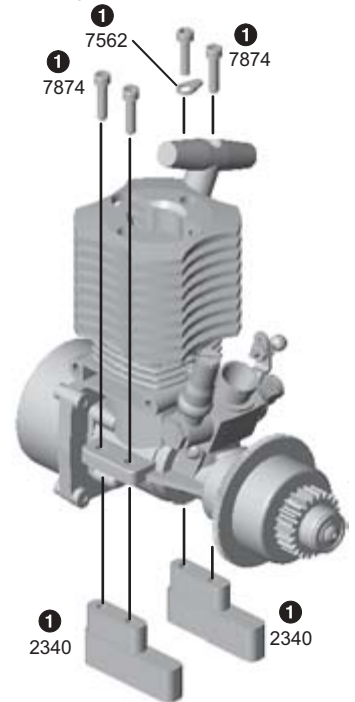

step 5B

- 1 Hook the #7562 throttle return spring to the throttle return spring mount and over the ball end of the carb's throttle arm.

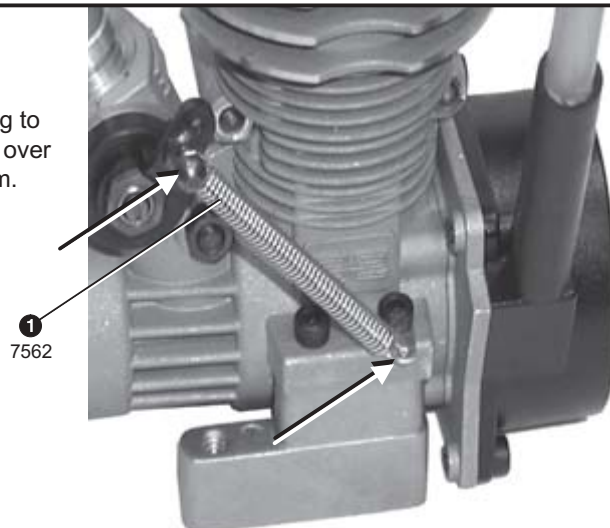

step 6

ENGINE INSTALLATION

- Place your engine assembly on top of the chassis. Attach the engine to the chassis with four #7773 screws. Do not tighten the screws yet.

GEAR MESH





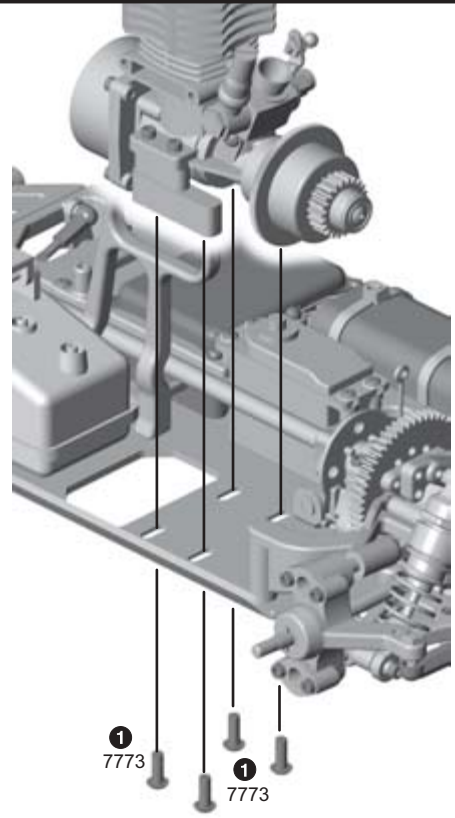





- Now we set the spur-to-pinion gear spacing, otherwise known as gear mesh. Make sure you can still slide your engine side to side, then mesh the clutch bell pinions with the spur gears.

The correct gear spacing is when the pinion is close to the spur gear, but if you hold the pinion gears, you should still be able to rock the spur gears back and forth slightly with light pressure. Roll the gears and check the mesh in several different locations on the spur gear. Now tighten the four motor screws. Recheck the mesh.

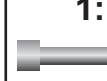

BAG 1

REMOVE THESE PARTS FOR: Step 7

 2343, qty 1 manifold	 7734, qty 1 manifold gasket	 7778, qty 2 3 x 30 screw black	 7730, qty 1 set screw	 3216, qty 1 washer	 6924, qty 1 4-40 x 3/8 screw
 7730, qty 1 muffler	 7733, qty 1 silicone tubing	 3719, qty 2 wire tie, 6"	 2344, qty 1 wire mount	 7778, qty 2 lock washer	

TOOLS USED

5/64", 3/32"

step 7

SIDE EXHAUST ENGINE

- Slide the two #7778 lock washers onto the #7778 screws. Attach the #2343 manifold to the engine with the #7734 manifold gasket in between with two #7778 screws.
- Cut a piece of #7733 silicone tubing to 1 inch in length. Slide one end of the tubing about half way onto the end of the manifold.
- Attach #2344 wire mount to the #7730 muffler with #7730 set screw.
- Slide the end of the #7730 muffler into the end of the tubing on the manifold to 1/8" from the manifold.
- Attach the other end of the wire mount to the chassis brace with one #3216 washer and one #6924 screw.
- Secure the silicone tubing with two #3719 wire ties.

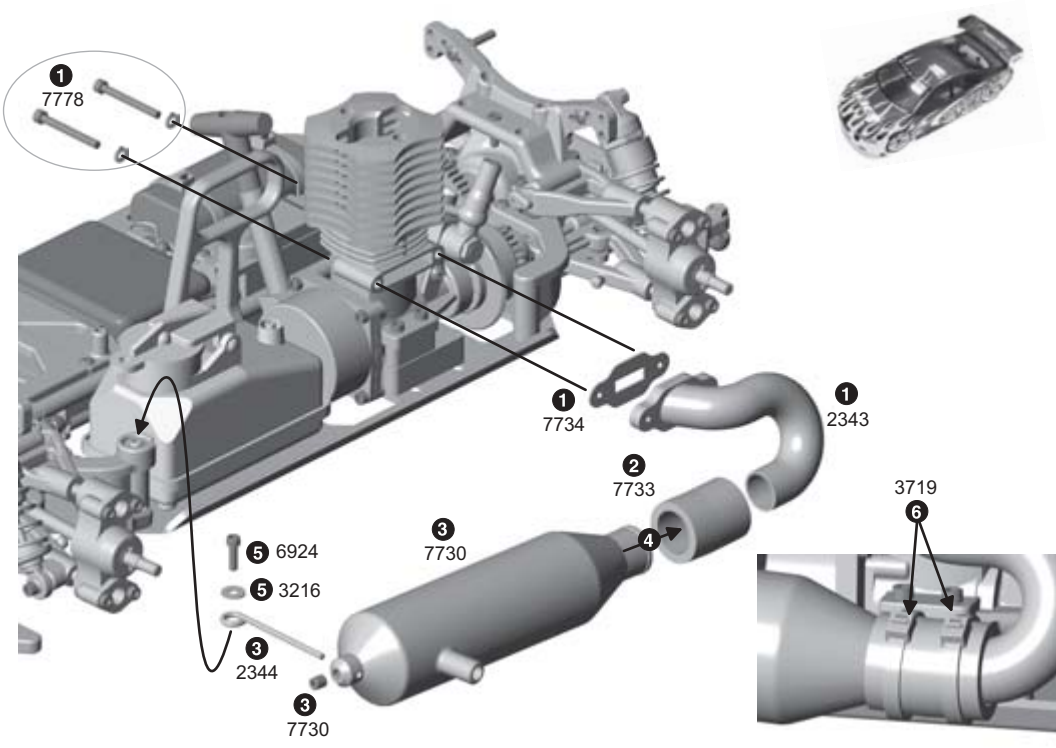

REMOVE THESE PARTS FOR: Step 8

7724, qty 1 fuel tubing

7709, qty 1 wire tie, 4"



step 8

FUEL TUBING

- 1 Cut one piece of #7724 fuel tubing 4 3/4" long. Slide one end onto the fuel fitting on your engine.
- 2 Run the fuel tubing along the side of the engine and place the second end into the first inlet of the fuel tank.
- 3 Cut a second piece of #7724 fuel tubing 10" long. Slide one end into the hole of the muffler about 3/8".
- 4 Wrap the fuel tubing into a small coil and to hold the coil use a #7709 wire tie. Tighten the wire tie just enough to hold the fuel tubing. Don't forget this step.
- 5 Place the second end of tubing into the second inlet on the fuel tank.

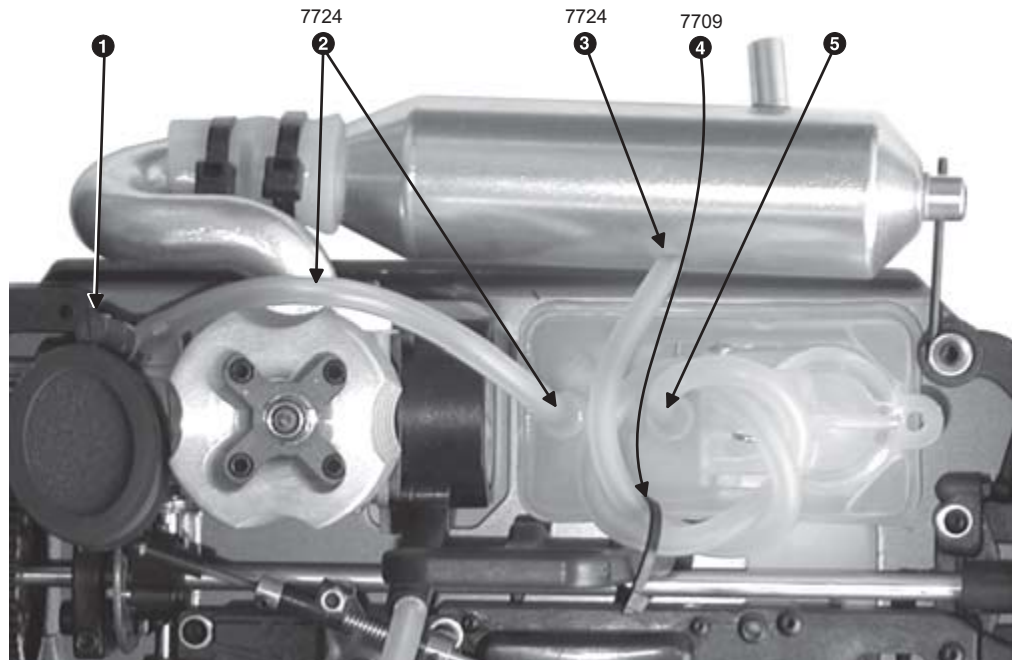

REMOVE THESE PARTS FOR: Step 9

2326, qty 1 throttle pivot

2337, qty 1 servo horn

1:1
6918, qty 1 4-40 x 1/2 screw

1:1
6466, qty 1 1/16" spacer

1:1
4449, qty 1 4-40 locknut

2326, qty 1 ball cup

2326, qty 1 throttle spring

2326, qty 2 collar

1:1
6951, qty 2 set screw

2326, qty 1 throttle rod

2326, qty 2 collar

6951, qty 2 set screw

2326, qty 1 throttle rod

.050", 1/16"

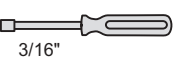

3/16"

step 9

ROTARY CARB ONLY

THROTTLE LINKAGE

- 1 Choose the correct servo horn for your throttle servo from the chart on page 20, step 4.
- 2 Notice that the servo horn has two arms next to each other with large holes. Thread a #6918 screw through the large outside hole of your servo horn. Slide a #6466 spacer and #2326 throttle pivot onto the screw then a #4446 nut. Only tighten the nut down enough so that the pivot can still move freely.
- 3 Thread a #2326 ball cup onto the end of the #2326 throttle rod. Slide on a #2326 collar and attach it 1/2" from the end of the ball cup with one #6951 set screw. Slide the throttle rod through the throttle pivot.
- 4 Slide one #2326 throttle spring onto the throttle rod next to the pivot. Attach the second #2326 collar to the rod with a #6951 set screw.
- 5 Cut off the remaining part of the throttle rod, leaving 1/2" length protruding so you can adjust your throttle linkage.

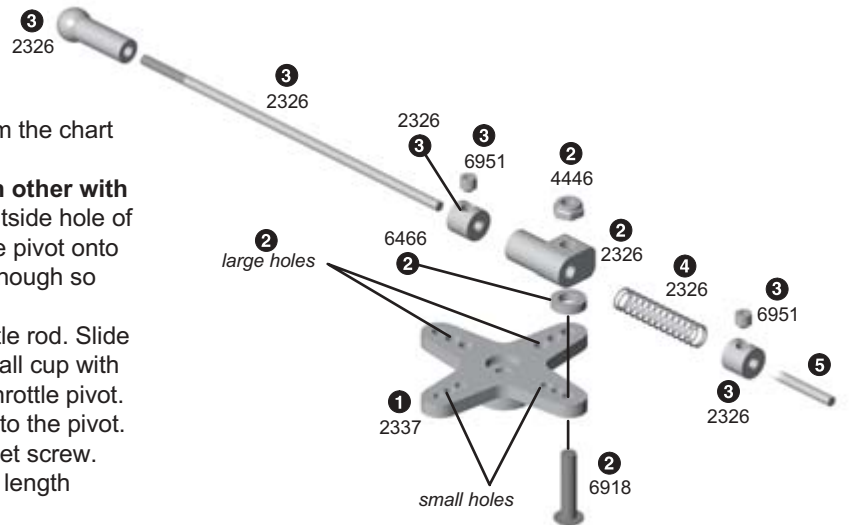

REMOVE THESE PARTS FOR: Steps 10-11

2326 qty 2
adjustment nut

2326, qty 1
brake rod

2326, qty 1
washer

4118, qty 1
spring, .014"

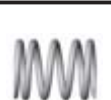
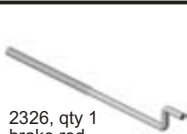

step 10 ROTARY CARB ONLY

BRAKE LINKAGE

- 1 Thread on one #2326 adjustment nut onto the #2326 brake rod about 9/16" from the rod's threaded end. Feed the other end of the brake rod through the middle (small) hole of the servo horn.
- 2 Slide on #4118 spring followed by #2326 washer.
- 3 Slide the threaded end of the rod through the opening on the brake cam lever and then place the servo horn onto your throttle servo. Secure the servo horn to the servo with your stock servo screw.
- 4 Thread on the second #2326 adjustment nut so that about 1/16" of the brake cam wire protrudes from the end.
- 5 Attach the #2326 ball cup onto the ball end on the carburetor.

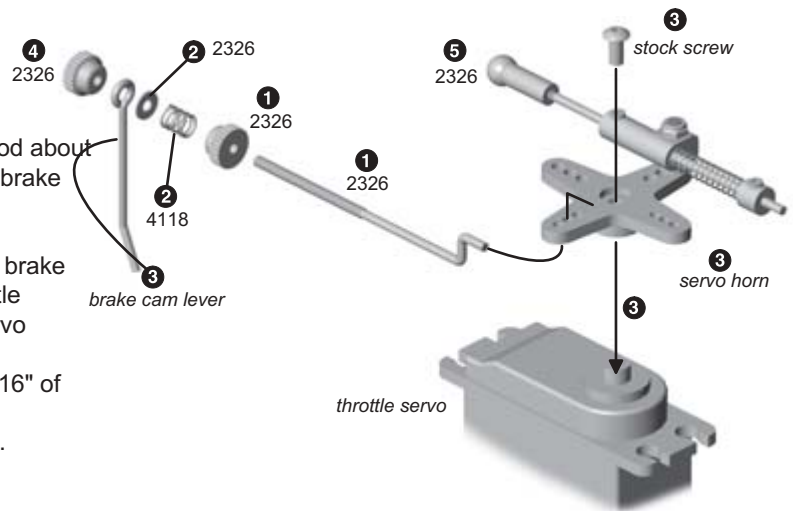

step 11

ADJUSTING THROTTLE LINKAGE

- 1 Turn on your transmitter and then the car's electronics (but don't start the engine). When at idle (trigger of transmitter not pulled), adjust the collar so there is 1/16" (1.58mm) of space between the collar and throttle pivot.
- 2 Apply full throttle (pull the trigger of your transmitter all the way back). Your carb should be almost fully open. If it is not, then adjust the collar near the throttle pivot. (You may also adjust your throttle trim according to your radio's instructions.)
- 3 Now apply the brake. Your carb should be in idle position. The spring should not be completely compressed.

IDLE

- 1 1/16" gap here

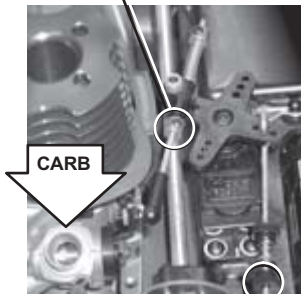

- 4 front brake nut

FULL THROTTLE

- 2 adjust if carb is not fully open

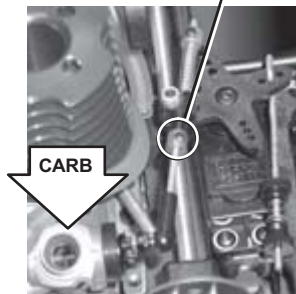

- 5

BRAKE

- 3

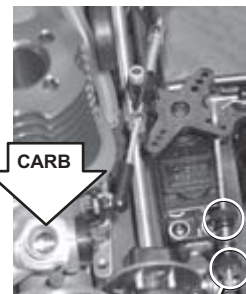

- 6 adjust collars if spur gear is not hard to move

ADJUSTING BRAKE LINKAGE

- 4 With the throttle trigger at idle, adjust the front brake nut so the brake is applied slightly. You can test this by turning the spur gear. The spur gear should have some resistance to it. Also, keep about a 1/16 gap between the back nut and the brake cam lever wire.

- 5 Now pull full throttle. The brakes should disengage immediately.

NOTE: Your NTC3 will require 2-3 tanks of fuel to sufficiently seat the brake shoes. The brakes will increase in power as this happens.

- 6 Now apply the brake fully. Your brakes should fully engage. The spur gear will be hard to move. If it is not engaged, adjust the collars or your setup in your radio to get the brakes to engage properly.



6918, qty 2
4-40 x 1/2 screw



6292, qty 2
4-40 x 3/8 screw



6923, qty 3
4-40 x 3/4 screw



6924, qty 1
4-40 x 3/8 screw



6332, qty 4
body clip

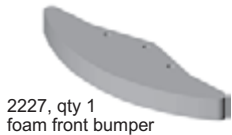
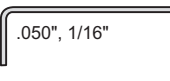

2227, qty 1
foam front bumper

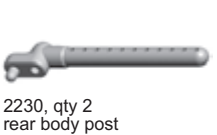

2230, qty 2
rear body post



2225, qty 1
bumper top plate



3879, qty 4
pivoting body mount



2230, qty 2
front body post

step 1

FRONT BODY POSTS

- 1 Attach #2230 front body posts to the #2225 bumper top plate with two #6292 screws.
- 2 Slide the #3897 pivoting body mounts over the body post so its holes line up with the fifth hole from the top. Slide in #6332 body clip to hold it in place. You may need to readjust this depending on your body style.

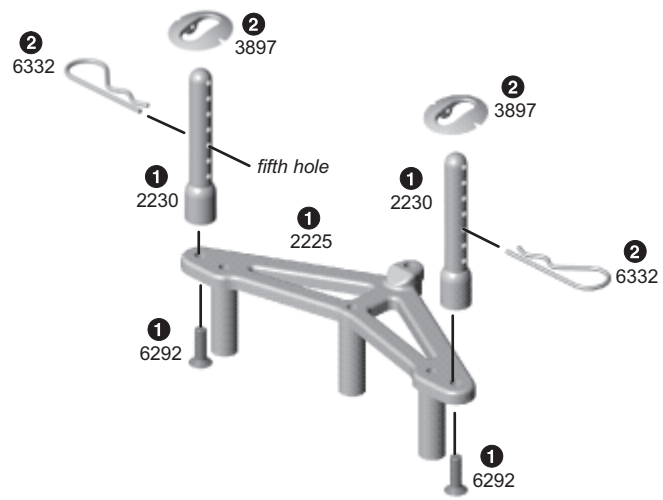

step 2

FRONT BUMPER

- 1 Slide the #2227 foam front bumper onto the bumper top plate assembly. Attach the foam and the bumper top plate to the lower bumper with three #6923 screws on the bottom and one #6924 screw on top.

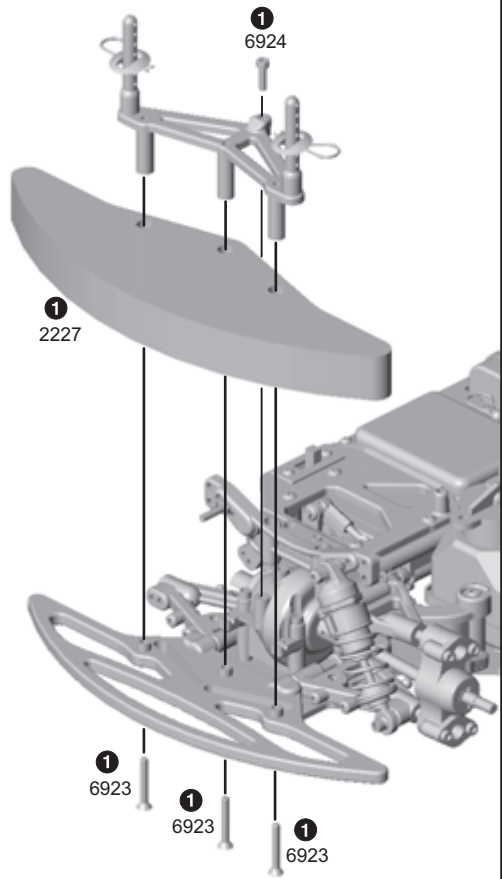

step 3

REAR BODY POSTS

- 1 Place the #2230 rear body post to the front side of the rear shock tower. Attach the post with a #6918 screw.
- 2 Slide the #3897 pivoting body mount over the body post so its holes line up with the fifth hole from the top. Slide a #6332 body clip in to hold it in place. You may need to readjust this depending on your body style.

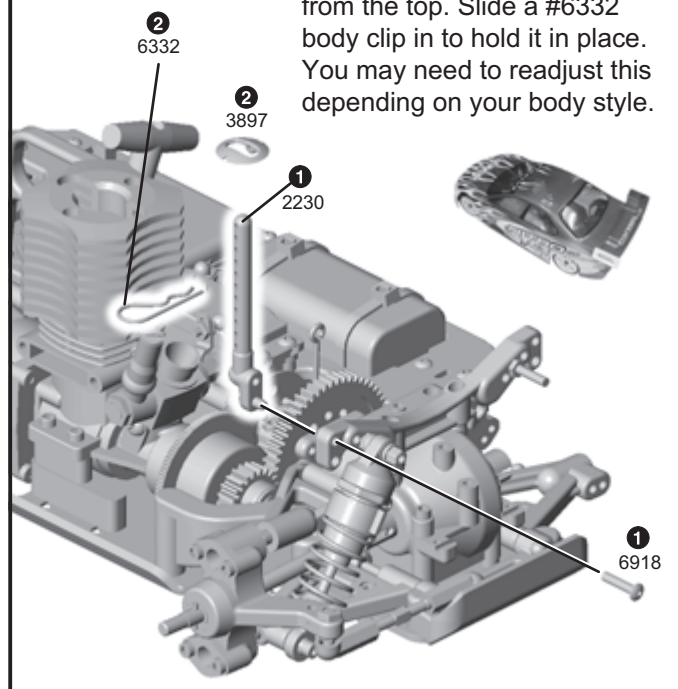



REMOVE THESE PARTS FOR:
Step 1



3989, qty 4
TC wheel



2405, qty 4
foam insert



2405, qty 4
TC tire



3950, qty 4
hex adapter



6943, qty 4
locknut

step 1

- 1 Install the #3950 wheel hex drive adapter to the axle, lining up the roll pin with the slot in the hex adapter.
- 2 Slide the wheels over the axle and tighten it down with a #6943 lock nut.
- 3 Install the remaining tires.

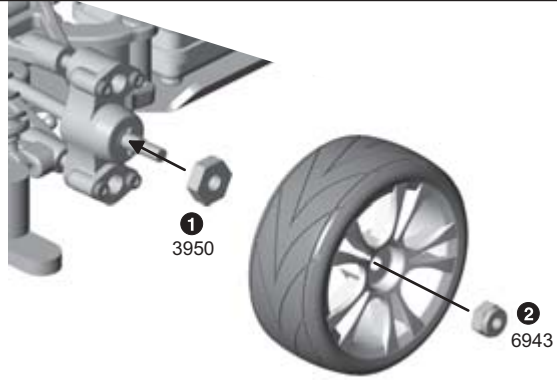

ABOUT THE ENGINE**What do I need to install a non pull start engine?**

#2341 non pull start mounts
 #2322 non pull start flywheel

Contact the engine manufacturer if you want to convert the engine itself.

How do I cut the crankshaft of my engine?

#7620 crank cutoff nut

Instructions are online:
<http://www.teamassociated.com/pdf/cutcrank.pdf>

How do I hook up a slide carburetor?

Instructions are online:
http://www.teamassociated.com/pdf/ntc3_slidecarb.pdf

How do I do the throttle/brake linkage for a slide carburetor?

Instructions are online:
http://www.teamassociated.com/pdf/ntc3_linkage.pdf

How do I install CVDs?

Instructions are online:
http://www.teamassociated.com/pdf/ntc3_cvd.pdf

What do I need to mount the muffler to a rear exhaust engine?

#2350 rear exhaust manifold
 #2353 rear exhaust muffler
 #2357 manifold spring
 #2358 mounting wire
 #2341 non pull start mounts
 #2322 non pull start flywheel

Instructions are online:
http://www.teamassociated.com/pdf/ntc3_rearexhaust.pdf

GENERAL QUESTIONS**Where can I find a track to race my car?**

A directory of shops and tracks is online. Go to our web site and click on *News & Links*, then scroll down to the Directory.

Where do I find painting ideas for a new body?

Try the *Racer Spotlight* online for painting inspiration. Go to our web site and click on *Racer's Stuff* then on *Racer Spotlight*.

How can I get the latest catalog?

Go to our web site and click on *R/C Parts*, then scroll down.

Where can I find other racer's setup sheets?

Go to our web site and click on *Racer's Stuff*, then scroll down.

Where can I find more bodies and tires?

Your local hobby store or track should carry a complete selection of each.

What does "AE" mean?

It stands for Associated Electrics, Inc. our company name.

How can I make my car go faster?

Change to a larger tooth 32 pitch clutch bell or smaller 32 pitch spur gear.

What size bodies fit my NTC3?

200mm touring car bodies.

UPGRADING YOUR RTR NTC3**What do I need to replace my axles with MIP CVDs?**

#3886 TC3/NTC3 CVD stub axle with hardware
 #3888 Factory Blue TC3/NTC3 aluminum CVD bones

What do I need to replace my single speed with a 2 speed clutch?

#2285 NTC3 two-speed assembly
 It depends on your engine. Download the exploded view of the NTC3 and check out the parts:
<http://www.teamassociated.com/pdf/catalogs/ntc3expl.pdf>

What other engines will fit in my car?

Almost any .12 or .15 short shaft glow fuel engine designed for R/C cars will fit, but not big block engines.

What do I need to install a front one-way?

#1705 NTC3 front one-way assembly.

SIGN UP NOW!

Sign up for the FREE *Team Associated Insider's Newsletter*. Get the latest news and parts for your car delivered right to your e-mail box!

FINAL ADJUSTMENTS

ADJUSTING CAMBER

To set the camber we recommend using our supplied #1719 camber/rear toe-in gauge. When adjusting camber you need to have the car ready to run with no body.



#1719 camber/rear toe-in gauge

Make these adjustments before racing

1. Set your car on a flat surface.
2. When using the camber / rear toe gauge, make sure that the number you want to set it at is down at the bottom of the tire. The gauge



has 1°, 2°, and 3° notations marked on it. Find the 2° and push it against the tire at the bottom.

Use your 5/64" Allen wrench to adjust the upper pivot ball to get 2°. We recommend 2° for most conditions.

CHECKING REAR TOE-IN

We recommended for you to start with 2° of rear toe-in, which is the default setup in the manual. To check or change rear toe-in use the supplied #1719 camber / rear toe-in gauge.

1. Stand your car up vertically on the rear arm mount.
2. When using the camber/rear toe gauge, make sure that the number you want to set it at

is down at the bottom of the tire. The gauge has 1°, 2°, and 3° notations marked on it. Find the 2° and push it against the tire at the bottom.



stand the car up vertically

3. Use your supplied #6956 molded turnbuckle wrench to adjust the rear turnbuckle to get the degrees you want.



ADJUSTING RIDE HEIGHT

The collars on the bodies can easily adjust the ride height. Use the supplied #1719 track width/ride height tool. The ride height tool will set your car at 5.5mm high.

1. When adjusting the ride height, have the car



#1719 track width/ride height tool

ready to run with no body.

2. Set the car on a flat surface.
3. Slide the height gauge underneath the rear of the chassis, as shown, until the gauge just touches the chassis. To get a better measurement on the chassis, you might need to slide



the gauge in the corner of the car. Check both corners of the rear.

4. Slide the gauge underneath the front of the car. Check both corners of the front.

CHECK RADIO / LINKAGE SETUP

CAUTION: Always turn your transmitter **on first** and **off last**. Remember this rule. If you start your car before turning on your transmitter then you may lose control of the car and damage the engine quickly.

Test the following radio functions without the engine started. These following steps will help you understand the operation of your transmitter.

1. Turn on the transmitter.
2. Turn the car receiver battery pack switch on. Both the steering servo and throttle servo should move to their respective neutral settings.
3. Turn the steering wheel on the transmitter left and right. The front wheels should turn left and right, then go to a perfectly straight-ahead position when the wheel is released. If they're a little off, set the steering with your steering trim. See your radio instruction manual for this

setting.

4. Pull the throttle trigger, which should open the carburetor on your engine.
5. Push the trigger forward, which should activate the brakes. Hold the throttle open and roll the car over the ground. The car should roll freely. While it is rolling, push on the brakes. The car should come to a stop. If these steps do not produce these results refer to the linkage assembly setup in this manual.

ADD AIR FILTER

NEVER run your touring car without an air filter. The filter is essential for keeping the dirt out of the engine. Refer to your engine manual for the recommended air filter for your engine. If you use a foam filter, use Associated's #7710 foam filter treatment.

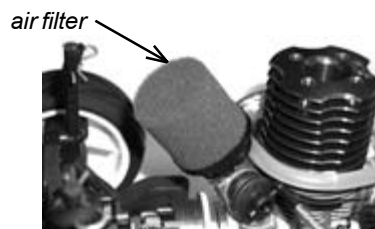

BODY

This kit accepts most 200mm touring car bodies. See body manufacturer's instructions on trimming and painting the body.

CAR FUEL

The proper fuel is very important for long engine life. Improper fuel can cause hard starting, poor performance, and excessive wear on the engine. The fuels we recommend for R/C car use are: O'Donnell Racing Fuel, Duratrax Red Alert fuel, Blue Thunder Race

Formula, FSR fuel, Trinity, Byron's Originals, Traxxas Top fuel, and Wild Cat fuel. There are many other racing fuels; however, they must meet two requirements:

1. The fuel must contain at least 18% of both castor and synthetic oils.
2. You should try to keep the nitro (nitromethane) between 10% to 20%. The

best fuels also contain rust and corrosion inhibitors, anti wear agents, anti foaming agents and lubrication additives.

CAUTION: DO NOT use any type of airplane fuels. Airplane fuels may not have the necessary oil types and ratios needed for R/C cars.

MAINTENANCE

You will find your Nitro TC3 will give you many hours of trouble-free operation when you familiarize yourself with these maintenance procedures.

You should periodically check all the moving parts:

Follow these steps to keep your car in shape for racing

Front and rear a-arms
Steering blocks
Steering linkage
Servo saver
Shocks
Clutch
Brake parts
Bushings and bearings
and other moving areas.

Check the radio system, the condition of the batteries, the fuel tank, and the hoses for leaks. Also check the firmness of the mounting of the receiver and servos, and check for any frayed wires or loose connections. Because of the vibration of gas engines, check the chassis and other critical screws for tightness after every run.

TUNING & SETUP TIPS

Your car is one of the most tunable touring cars on the market. This section will try to explain the parts and adjustments you can use to tune your car for different track conditions.

CASTER

Caster describes the angle of the kingpin from vertical when looked at from the side of the car. Positive caster means the kingpin leans rearward at the top.

The Nitro TC3 standard kit setup is 9° of caster. The car can be adjusted in 3° increments (6°, 9°, and 12°).

These tips prepare your car for maximum performance

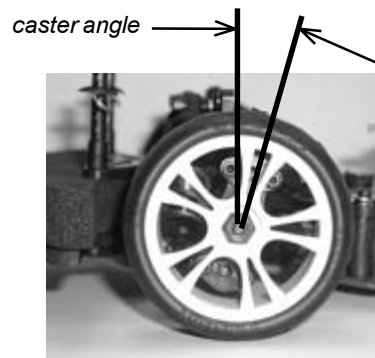

Increasing caster in the nitro TC3 will give your car more turn-in steering, but less steering exiting the corners. It will also be more stable in bumpy conditions. Decreasing caster will give the car less turn-in steering, but will give your car more steering exiting corners. It will be less stable in bumpy conditions.

Change the caster by moving the caster clips shown on page 15, step 6. Both clips to the front results in 6° caster. Both clips to the rear results in 12° caster.

FRONT TOE-IN AND TOE-OUT

You can adjust front toe by turning the steering turnbuckles. Toe-in will make your car easier to drive by improving stability during acceleration. Toe-out will increase steering when entering corners, but will be slightly more difficult to drive. We suggest using 0° to 1° toe-out on the nitro TC3.

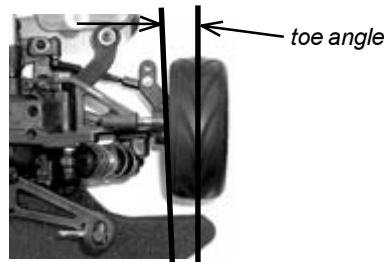

Use this tool on the turnbuckle to adjust toe

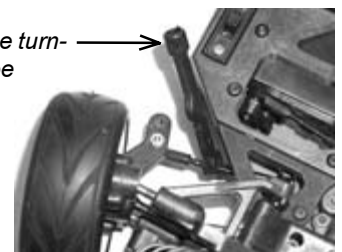

ACKERMAN

This is a term describing the effect of the inside front wheel turning tighter than the outside front wheel. The standard setup works best in most conditions and is preferred by most of our team drivers.

By changing the two #3857 special ball ends with two longer neck #6270 ball ends to the swing rack, a more aggressive steering feeling can be achieved. This is because there will be less Ackerman.

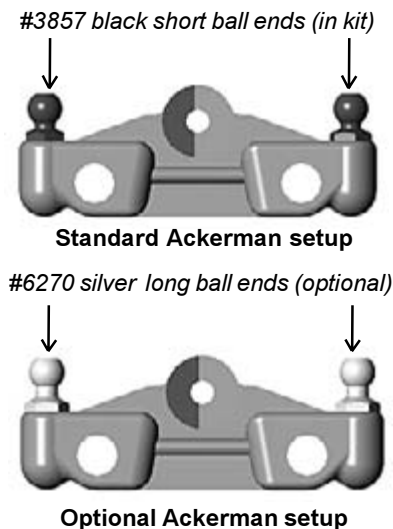

2 SPEED GEARING (optional)

With the optional #2285 NTC3 2 Speed, use the following combination of pinion and spur gears in the 2 speed to maintain the correct gear mesh.

20/24 with 52/48	21/27 with 54/48
21/25 with 52/48	20/24 with 54/50
22/26 with 52/48	21/25 with 54/50
23/27 with 52/48	22/26 with 54/50 (in kit)
	23/27 with 54/50

CAMBER

Camber describes the angle the wheels ride relative to the ground when looked at from the front or back. Negative camber means that the tire leans inward at the top. Positive camber means just the opposite, and should not be used. We suggest using 2° to 3° of negative camber on high traction tracks and using 1° to 2° on low traction tracks. Setting the camber was explained to you in Final Adjustments.

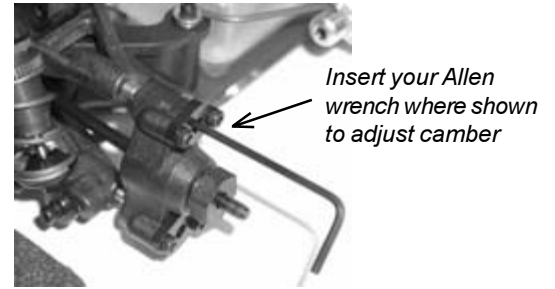
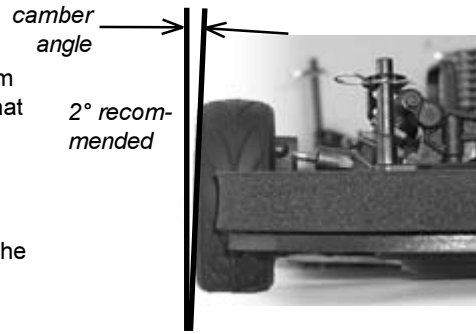

REAR TOE-IN

Toe-in is fully adjustable and can be adjusted by changing the rear turnbuckle length. The setup we recommend is 2° of toe-in on each side. The setting should work best in most conditions. Decreasing the rear toe you will decrease rear traction and add steering. We do not recommend running more than 3° of rear toe-in.

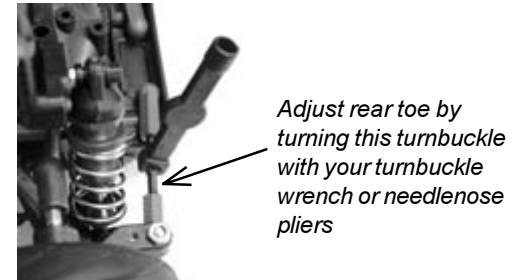
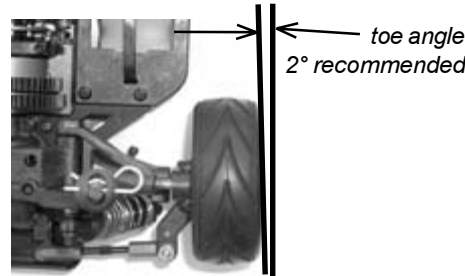

CAMBER LINK LOCATION

The Nitro TC3 has been thoroughly tested to find the best all-around positions. We suggest using the standard setting for almost all conditions.

The optional position will give your car more overall traction in slippery conditions.

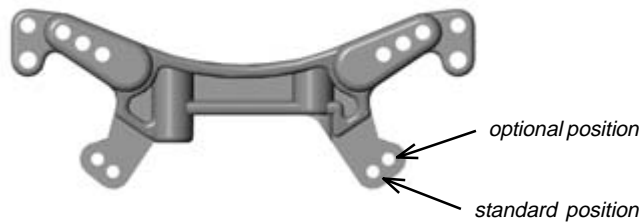

DROOP

Droop can be adjusted on the Nitro TC3 to help speed up or slow down how fast the car changes direction when cornering. The NTC3 standard setup is setting 4 in the front and setting 3 in the rear. This will work best in most track conditions. See page 5 for setting droop.

If your track is bumpy, you may want to add droop to your car by going to a lower droop gauge setting.

If your track has very high traction, such as carpet, then you want to take droop out of your car by going higher on the droop gauge. Too little droop will cause a loss of traction.

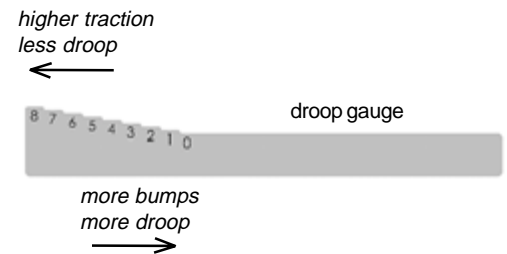

TWO-SPEED ADJUSTMENT (optional)

With the optional #2285 2 Speed kit, your NTC3 will be more competitive. By increasing or decreasing the spring tension you can change the shift point of your two-speed. If you want the car to shift into second gear later, tighten down both screws equally ¼ of a turn to increase the spring tension. If you want the car to shift into second gear sooner, loosen both screws equally ¼ of a turn to decrease the spring tension. Make your adjustments in ¼ turn amounts. Run your car first before you make any adjustments to the two-speed.

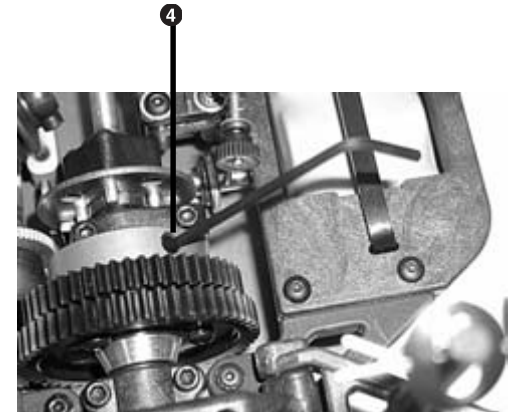
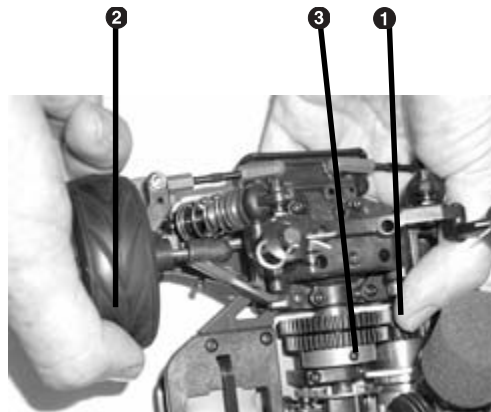

To adjust your 2-speed (turn off your engine):
1. Lift the car and hold the spur gear in place with your thumb, the bell opening (3) facing up.

2. Turn the rear wheel slowly.
3. Watch for the adj. screw to appear in the opening of the 2-speed bell. It will be a black screw, at an angle. When looking at the front of the 2-speed, there will be a number 1 and 2 on the shoes where the adjustment

screws are located.
3. Insert your Allen wrench and adjust as needed.
4. Remove Allen wrench and turn the rear wheel again and repeat for the second set screw, adjusting it the same amount.

SHOCK SPRINGS

Shock springs keep your car level during acceleration, deceleration, and cornering.

Stiffer springs will help your suspension respond more quickly, but because of their stiffness will not absorb bumps as well. Use stiffer springs in high traction conditions such as carpet.

Softer springs are best for slippery or bumpy conditions.

Part #	Color Code	Rating
#3941	Green	12 lbs.
#3942	Sliver	14.5 lbs.
#3943	Blue	17 lbs.
#3944	Gold	19.5 lbs.
#3945	Red	22 lbs.
#3946	Copper	25 lbs.
#3952	Purple	30 lbs.
#3953	Yellow	35 lbs.
#3954	White	40 lbs.

ANTI-ROLL BARS (optional)

Roll bars are used to stabilize a car from excessive chassis roll (which occurs when your car leans through the turns by centrifugal force). Anti-roll bars are generally used on smooth, high traction track conditions. If the track is bumpy and are slippery, then roll bars are not needed.

If you're driving on a high traction condition and your car wants to oversteer, then use optional #1715 front blade anti-roll bar kit. This will decrease the front chassis roll and decrease steering throughout the corner.

If your car is understeering, then try the optional #3960 anti-roll bar kit in the rear only. The rear anti-roll bar will decrease rear chassis roll and decrease rear traction.



#3960 Anti-roll Bar Kit (optional)



#1715 Front Blade Anti-roll Bar Kit (optional)

CLUTCH ADJUSTMENT

When the engine revs increase, the clutch shoes, attached to the flywheel on the shaft inside the clutch bell, are flung outward by centrifugal force. The shoes engage to the inside of the clutch bell, which in turn power the clutch bell to accelerate the car. The shorter the clutch shoes or the stiffer the clutch spring (optional), the higher the engine must rev before the clutch shoes will engage. This is recommended for lower power engines. The stock (longer) length clutch shoes and stock clutch springs (softer) will have the quickest engagement. This is recommended for most track conditions and high power engines.

To adjust your clutch, you can change the number of shoes, alter their length or change the clutch spring. Changing shoes

mainly depends on the current track conditions. The stock clutch springs are recommended for most conditions. In general, the higher the traction the longer the shoes, which prevents tire spinning. To decrease the clutch engagement, try cutting the clutch shoes a little shorter using a hobby knife. Do not trim away more than necessary, or your engine can get damaged due to the engine over-revving.

Optional Parts:

- #2324, non pull start 3-shoe flywheel
- #2325, pull start 3-shoe flywheel
- #2307, optional clutch springs

SETUP SHEET

A blank setup sheet for the NTC3 is included. Set up your NTC3 with the standard settings at right, then deviate from them in response to your track conditions and driving style, as noted below.

Tips for beginners:

For best results, make only one setup change at a time, testing it before making another change. Make a copy of the setup sheet included in the back of this manual to help keep track of your changes.

Before you make any changes to the standard settings, make sure you can get around the track without crashing. None of your setup

changes will work if you cannot stay on the track.

Your goal is consistent lap times. Inconsistent lap times may indicate poor control. When you have consistent lap times, then make changes to your car.

If the change results in a faster lap, then mark the change in your setup sheet. If performance is worse, then revert back to the previous setup and try another change.

Fill out your setup sheet thoroughly when you are satisfied with it and file it away. It can be a practical guide for future track layouts and conditions you encounter.

TRACK WIDTH

You can adjust the track width of the NTC3. That is, you can widen the distance between the outside front wheels.

To adjust the track width of your car, see the instructions on page 14.

VISIT TEAMASSOCIATED'S WEB SITE FOR:

- Setup sheets
- New products
- Tuning tips —setting up your car to the track
- Customer support
- Body painting ideas in the Racer's Spotlight section
- Computer wallpaper
- Catalog and manual
- Subscribe to our FREE *Team Associated Insider's Newsletter*—delivered right to your e-mail box!
- Racer apparel and car carrier
- Hobby shop & track locations worldwide
- Spring rate chart and other charts
- Nitro engine troubleshooting tips
- Helpful tools
- TC3/NTC3 Forum

**NITRO
TC3
RTR**

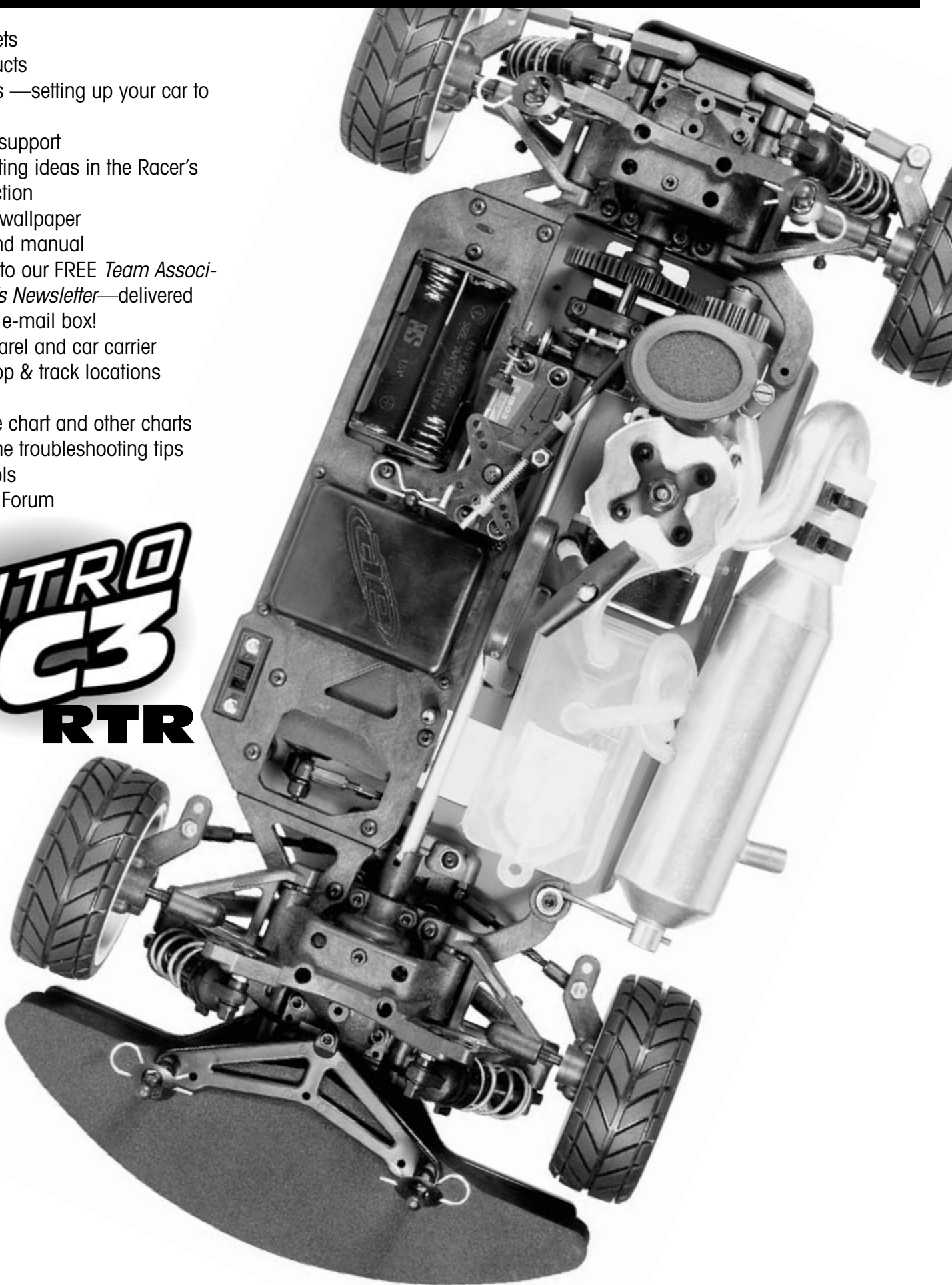

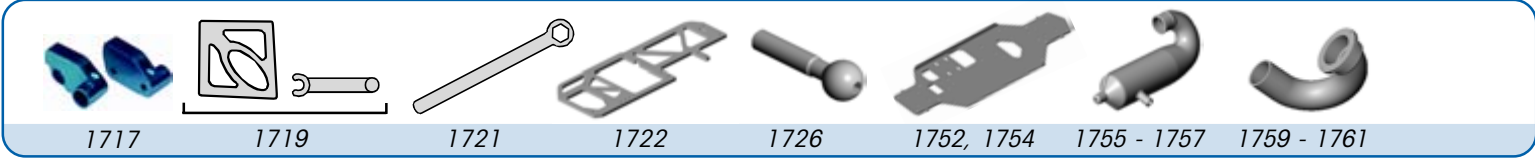

For the Nitro TC3 Touring Car



1402	Factory Blue 1.375 Turnbuckles	8.00
1414	Factory Blue 1.125 Turnbuckles	9.00
1415	Factory Blue Rear Toe Turnbuckles	9.00
1450	Factory Blue Ride Height Gauge, set ride height easily	14.99
1598	Factory Blue Shock Caps, Blue anodized aluminum(4) ..	11.95
1700	NTC3 FT Light Weight Two-Speed One-Way Hub	22.00
1701	NTC3 FT Light Weight Two-speed Clutch Housing	15.00
1702	NTC3 FT Light Weight Two-Speed Clutch Bell	8.00
1704	NTC3 Solid F/R Axle	30.00
1705	NTC3 Front One-Way assembly	60.00
1706	NTC3 FT Blue Alum. Center Bulkhead	22.00
1707	NTC3 One-Way Outdrive Shafts	22.00
1708	NTC3 FT Blue Alum. Pull Start Motor Mounts	20.00
1709	NTC3 FT Brake Cam Bearing Kit	7.00
1710	NTC3 FT Blue Alum. Non Pull Start Motor Mounts	20.00
1711	NTC3 FT PTFE-Sealed Bearing Set	95.00
1712	NTC3 FT Blue Alum Main Drive Shaft	9.00
1713	Factory Blue NTC3 Turnbuckle Kit	22.50
1714	NTC3 FT Swing Rack Bearing Kit	12.00
1715	NTC3 FT Front Blade Roll Bar Kit	40.00
1717	NTC3 FT Blue Alum. Blade Roll Bar Mounts	24.00
1719	Factory Team Camber + Track Width Tool	3.50
1721	Clutch Nut Wrench 3/8"	2.00
1722	Factory Team Graphite Radio Tray	39.00
1726	NTC3 Titanium Pivot Balls	15.99
1749	Nitro Fuel Bottle, double O-ring sealed.....	7.99
1752	NTC3 Hard Chassis, Black	49.99
1754	NTC3 Hard Chassis, Natural	49.99
1755	NTC3 Rear Exhaust Blue Muffler	54.99
1756	NTC3 Rear Exhaust Natural Muffler	54.99
1757	NTC3 Rear Exhaust Black Muffler	54.99
1759	NTC3 Rear Exhaust Blue Manifold.....	14.99
1760	NTC3 Rear Exhaust Natural Manifold	14.99
1761	NTC3 Rear Exhaust Black Manifold.....	14.99
1763	NTC3 Rear Exhaust Blue Dual Chamber Muffler	59.99
1764	NTC3 Rear Exhaust Natural Dual Chamber Muffler	59.99
1765	NTC3 Rear Exhaust Black Dual Chamber Muffler	59.99

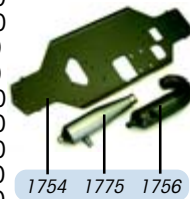
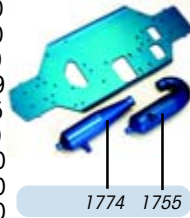

1767	NTC3 Side Exhaust Blue Manifold	17.99
1768	NTC3 Side Exhaust Natural Manifold	17.99
1769	NTC3 Side Exhaust Black Manifold	17.99
1771	Torque-tuned Side Exhaust Blue Muffler (kit std.)	31.99
1772	Torque-tuned Side Exhaust Natural Muffler (kit std.)	31.99
1773	Torque-tuned Side Exhaust Black Muffler (kit std.)	31.99
1774	RPM-tuned Side Exhaust Blue Muffler	31.99
1775	RPM-tuned Side Exhaust Natural Muffler	31.99
1776	RPM-tuned Side Exhaust Black Muffler	31.99
2236	NTC3 Carbon Front Arm Set	11.00
2241	NTC3 Carbon R/L Steering / Hub carriers	7.00
2244	NTC3 Carbon Rear Arm Set	11.00
2248	NTC3 Carbon F/R Shock Tower	7.00
2255	NTC3 Carbon Chassis Braces	8.00
2259	NTC3 Carbon Radio Tray.....	8.00
2261	NTC3 Carbon Handle	4.50
2324	NTC3 Non Pull 3 Shoe Flywheel	9.00
2325	NTC3 Pull Start 3 Shoe Flywheel	9.00
2371	NTC3 Carbon Set.....	67.95
3888	Factory Blue TC3 / NTC3 Aluminum CVD Bones (2)	22.00
3939	TC3 / NTC3 Front One-way / Solid axle Differential Ring Gear with Mounting Screws	6.00
3941	TC3 / NTC3 Green Spring, 12.0 lbs.	5.00
3943	TC3 / NTC3 Blue Spring, 17.0 lbs.	5.00
3945	TC3 / NTC3 Red Spring, 22.0 lbs.	5.00
3946	TC3 / NTC3 Copper Spring, 25.0 lbs.	3.00
3949	TC3 / NTC3 Wheel Hex Adapters (4), Graphite	5.00
3952	TC3 / NTC3 Purple Spring, 30.0 lbs.	5.00
3953	TC3 / NTC3 Yellow Spring, 35.0 lbs.	5.00
3954	TC3 / NTC3 White Spring, 40.0 lbs.	5.00
3960	TC3 / NTC3 Rear Anti-roll Bar Kit.....	8.00
3962	TC3 Factory Blue-Anodized Threaded Body Shock Kit (set of 4)	60.00
3963	Factory Blue-Alum. Threaded Shock Bodies with collar (pair)	20.00
3964	TC3 / NTC3 UNOBTANIUM Shock Shafts, .35 (pair)	11.00
3968	Factory Blue Counterfeit Transponder	15.00
3972	TC3 / NTC3 Blue Aluminum Wheel Hex Adapters.....	15.00
3988	Complete TC3 / NTC3 Tuning Spring Set (9 pair).....	34.99
6439	Factory Team Shock Cap, Blue anodized aluminum.....	3.00
7710	Pre Filter Treatment	2.50

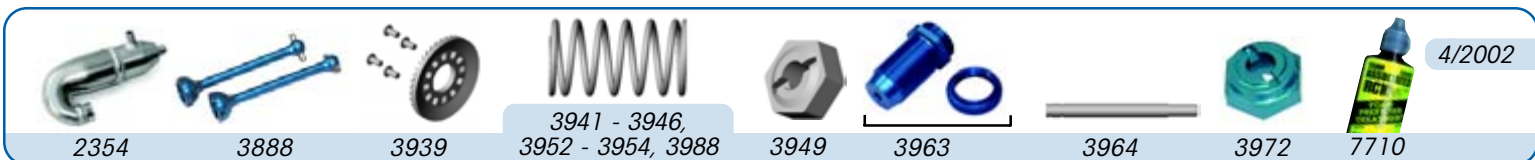
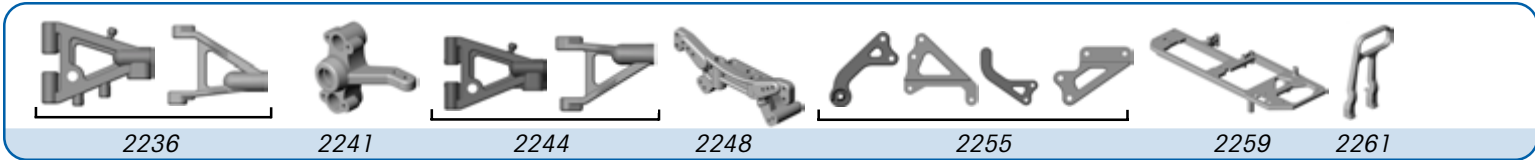
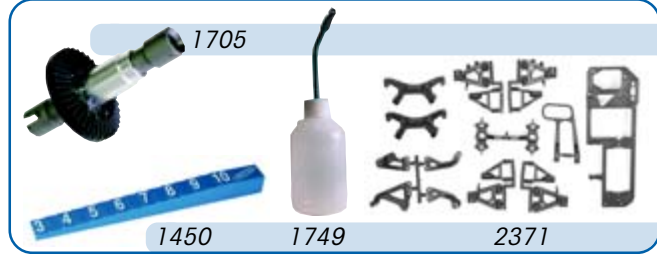



SETUP SHEET for the Team Associated

Driver _____
Track / City _____
Event _____ Date _____

FRONT SUSPENSION

CASTER ___ 6° ___ 9° ___ 12°
CAMBER ___ °
TOE-IN ___ °
RIDE HEIGHT ___ mm
DROOP _____
BUMP STEER SPACERS _____"
ANTI-ROLL BAR
___ none
___ 3960 kit
___ 1717 front blade kit
___ blade setting
ACKERMAN
___ STD (3857 ball ends)
___ opt. (6270 ball ends)
DRIVESHAFTS
___ MIP
___ other

FRONT SHOCKS

BODY
___ threaded
___ other
SPRING (color) _____
OIL ___ wt
PISTONS # _____
SHAFTS
___ unobtainium
___ STD
TOWER MOUNTING
___ inner hole
___ middle hole
___ outer hole
CAMBER LINK
___ inner hole
___ outer hole
ARM MOUNTING
___ inner hole
___ outer hole

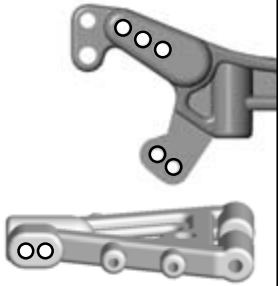

REAR SUSPENSION

CAMBER ___ °
TOE-IN ___ °
RIDE HEIGHT ___ mm
DROOP _____
ANTI-ROLL BAR
___ none
___ 3960 kit
DRIVESHAFTS
___ MIP
___ other

REAR SHOCKS

BODY ___ threaded ___ other
SPRING (color) _____
OIL ___ wt
PISTONS # _____
SHAFTS
___ unobtainium
___ STD
TOWER MOUNTING
___ inner hole
___ middle hole
___ outer hole
CAMBER LINK
___ inner hole
___ outer hole
ARM MOUNTING
___ inner hole
___ outer hole



OTHER

FRONT TIRES _____
FRONT INSERTS _____
FRONT WHEELS _____
REAR TIRES _____
REAR INSERTS _____
REAR WHEELS _____
TIRE ADDITIVE _____
___ none
TRACK WIDTH
___ STD (gauge) ___ (in./mm)
WEIGHTS
___ none ___ (oz./gm)
FUEL BRAND _____
NITRO ___ 20% ___ %
ENGINE BRAND _____
___ pull start ___ non pull start
___ .12 ___ .15 ENG. TEMP. ___ °
CARB ___ rotary ___ slide valve
CARB RESTRICTOR ___ none ___"
ONE-WAY ___ none ___ front
SOLID AXLE ___ front ___ rear
FRONT DIFF SETTING _____
REAR DIFF SETTING _____
BODY _____
RADIO _____
ST. SERVO _____
THR. SERVO _____
1st GEAR PINION / SPUR ___ / ___
2nd GEAR PINION / SPUR ___ / ___
Sigle Speed: PINION / SPUR ___ / ___
CLUTCH ___ 2 shoes ___ 3 shoes
CLUTCH SHOES ___ not cut ___ cut
CLUTCH SPRINGS ___ STD ___ other
GLOW PLUG TYPE _____
TUNED PIPE _____

TRACK CONDITIONS

SURFACE ___ smooth ___ bumpy
TRACTION ___ low ___ medium ___ high
COMPOSITION ___ concrete ___ asphalt ___ carpet
specify: _____
NOTES _____

RACE COMMENTS

MAIN ___ FINISH ___ QUALIFYING POS. ___
NOTES _____

CAR COMMENTS

NOTES _____

