

NEW! with
STEALTH transmission
and new shocks

CHAMPIONSHIP EDITION

RC10



INSTRUCTION MANUAL

The New RC10's Latest Technology

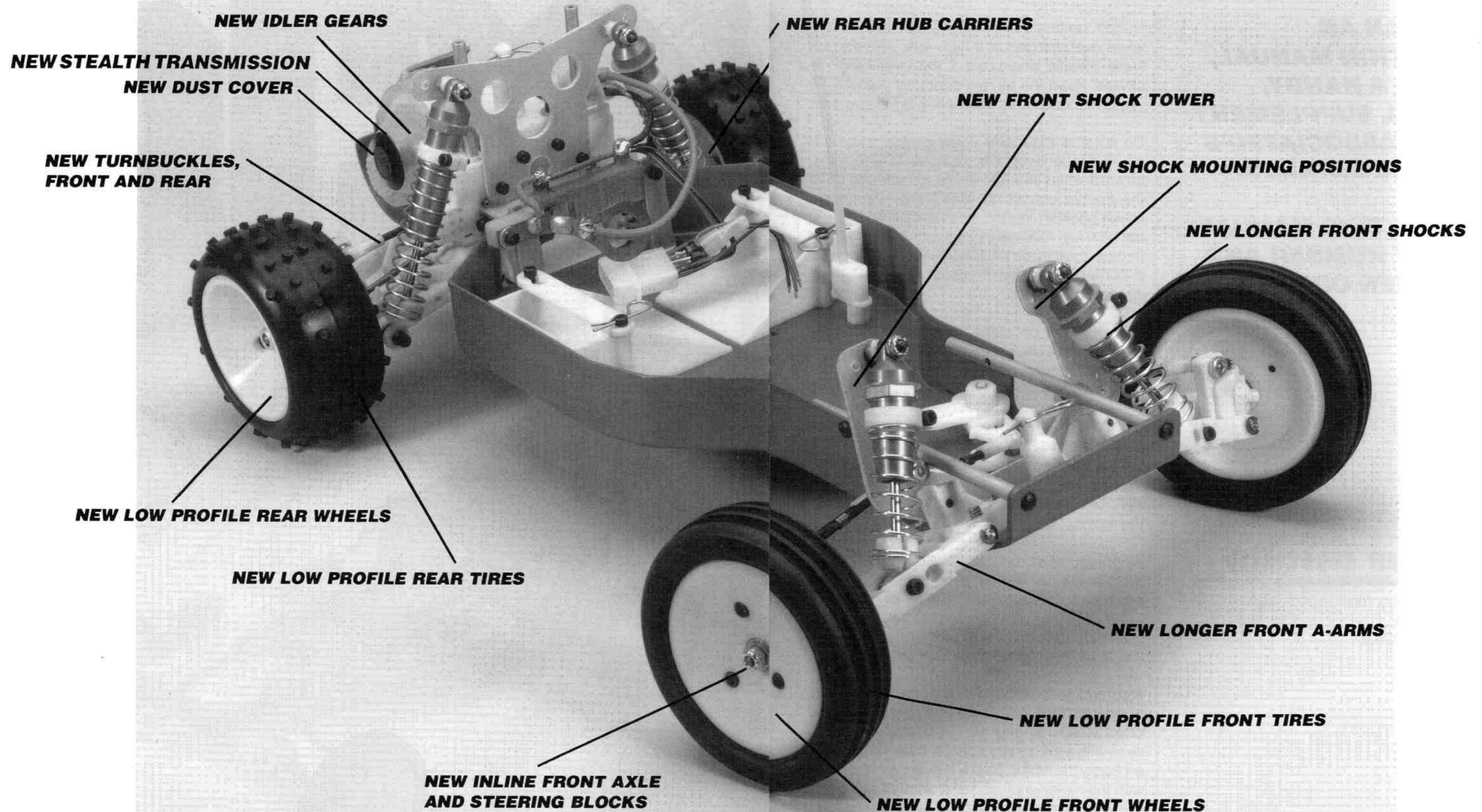

Advanced, Competition Version of the RC10

SAVE THIS BOOKLET!

**MORE THAN AN
INSTRUCTION MANUAL,
IT'S ALSO A HANDY,
PICTORIAL SUPPLEMENT
TO TEAM ASSOCIATED'S
1:10 SCALE CATALOG.**

**REFER TO THIS MANUAL
FOR PART NUMBER AND
NAME WHEN ORDERING.**



Associated Electrics, Inc.
3585 Cadillac Ave.
Costa Mesa, Ca 92626

CAUTION

Ni-cad batteries are susceptible to damage when overcharged at a high rate, and can release caustic chemicals if the overcharge is severe. Read the battery charging instructions in this manual before attempting to run your car.

Do not stall the motor under power. If the car stops suddenly on the track, or fails to move forward when you attempt to accelerate, push the throttle control on your transmitter to the brake position immediately and attend to the car. A small rock can stall the gears, and if the throttle is left in the on position the result can be a burned out motor or resistor (or electronic speed control unit).

If you run your car to the point where more than one cell in the pack is completely discharged, it is possible to lose radio control of the car before the drive motor stops completely. For this reason you should not operate your car in an area where it could be harmed or cause harm, such as near a busy roadway or a pool of water. Usually radio control will be regained as soon as you pick up the car and the motor is allowed to free-run. If you still don't have control, then you should unplug the motor.

When you stop running your car, turn off the radio at the car first (with the resistor in the off position) before turning off the transmitter.

Be sure that the resistor is in the off position while you are charging the battery.

A burned-out or shorted motor can make the car appear to have radio problems. If the car slows down suddenly and the radio acts erratically even with a full battery charge, then the cause is probably the motor. Check the range of the radio with the motor unplugged. A shorted motor will draw extremely high current even under no-load conditions.

FIRST, A WORD

Our original RC10 car has won more IFMAR World Championships and ROAR Nationals combined than all the other 2WD off-road winning cars put together. It is by far the most popular 2WD off-road RACE car in the world. The READERS of RC CAR ACTION magazine voted the RC10 as CAR OF THE YEAR by a 6 to 1 margin over the 2nd place car! The racers know which car is best.

As great as the original RC10 is, we wanted something better, and we know you did too, so we've brought out the new RC10. At first glance it looks like a regular RC10. But it's much more than that. It has the NEW Stealth Transmission, NEW longer front A-arms with two shock mounting positions. NEW inline front axle and steering blocks which greatly improve the steering. NEW front shock towers which give more ideal shock mounting positions. NEW rear hub carriers with more toe-in for greater stability. NEW turnbuckles for easier adjustments. NEW low profile front and rear wheels and tires, giving more steering in the front end and more traction in the rear end. Which all adds up to give you the best 2WD car in the world.

You'll find the photos in the instructions so easy to follow that you may be tempted to put the car together from the photos alone. However, although you have the best car kit, if you want the best COMPLETED model race car, then you will want to put it together correctly--by following these instructions. All that's required is to read the few lines of text near each photo.

DON'T OPEN ANY OF THE PARTS BAGS UNTIL THESE INSTRUCTIONS TELL YOU, otherwise you'll get the parts mixed up and then you will have trouble assembling your car.

While you are building the car you will sometimes be working with several parts bags at the same time. These bags are referred to by number in the instructions, and you will find a number label on each of the main parts bags. There are also more bags inside the main parts bags; these are not numbered and belong to the bag they came out of. See pages 54-56 for the list of parts and bags in your kit.

Bags and parts will start multiplying like rabbits as you build, so try to keep the bags separate. One good way is to use large paper plates (picnic plates with partitions are best). Mark the plates with bag numbers and dump the parts into them. When the parts are used up, relabel the plate for another bag. It's much easier to find the part you need if it's spread out where you can see it.

TOOLS. The kit contains the shock wrench and all the Allen wrenches you'll need, but you will have to supply the following:

- #2 Phillips screwdriver (Associated #SP76)
- A needle-nose pliers
- A hobby knife, such as an X-acto with a pointed blade.
- A soldering iron (40 to 50 watts), and a small amount of ROSIN (not acid) core 60/40 solder.

The kit can be assembled even easier if you have the following:

3/32" straight Allen wrench with handle. Will make installing the Allen screws much faster and easier (Associated #SP73)

A ruler with decimal inches or metric measure
A 3/16" nut driver will make installing the ball ends easier (Associated #SP86)

A 1/4" nut driver will speed up installing the 1/4" nuts (#SP85)

Socket or open-end wrench

Small screwdriver

Thread-locking compound

ZAP or Hot Stuff (cyanoacrylate adhesive)

Vise

File

Drill with #43 (2.3MM) bit

WARNING! Do not use a power screwdriver. They spin too fast, causing screws to heat up when being driven into plastic and will strip out.

Take your time assembling the car. It's not a race to see how fast you put the car together; it's how well you put it together that determines how fast you'll be able to race.

A box is provided at each step so you can check it off after each step is completed. If you stop during assembly time, you'll be able to come back where you left off.

To help you identify certain hardware, an outline drawing occasionally will accompany the step. Just place your part atop the actual-size drawing to be sure it's the one referred to.

One final note for you experienced, new builders and racers: **please build the car our way first!!** The RC10 is a remarkably fast car right out of the box. There's a reason for everything on the car, and very few compromises were made in its design. Work with the car first and see what it can do before you experiment or make changes.

Clear off your workbench, line up some paper plates, grab a sandwich, and let's begin...

□ **Fig. 1** We'll start with Fig. 1. Only take the parts out of the bag that we tell you, and no others. Look for bag #6-4 and take the #6310 gold anodized nose piece out of the bag, as shown in the photo and the #6931 8/32 x 1/4" Phillips flat head screw, as shown. Now take the two #6281 8/32 x 7/8" Phillips screws out of bag #6-2. DO NOT take anything else out of the bag.

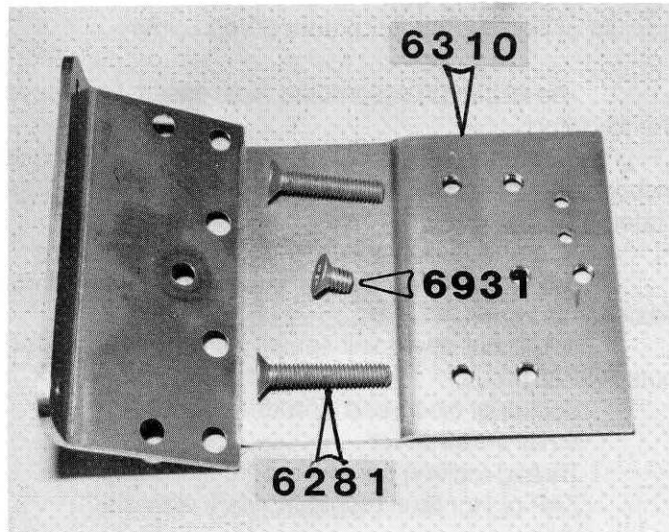

Fig. 1



□ **Fig. 3** From bag #6-5, take one #6330 body mount, two #3323 (#8) aluminum washers and one short #6280 8/32 x 1/2" FHMS screw. (The long screw is used to extend the body mounts for other body styles.)

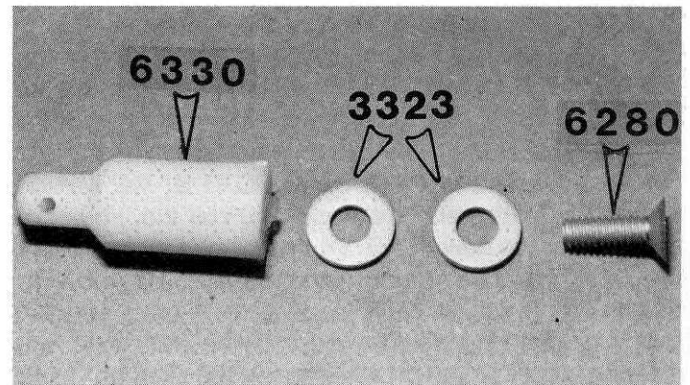
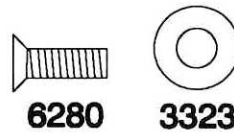

Fig. 3



□ **Fig. 2** Take the #6300 gold aluminum chassis and install the nose piece as shown, using the two 8/32 x 7/8" FHMS and the 8/32 x 1/4" FHMS. **NOTE:** All of the gold screws are aluminum and can be damaged by a worn screwdriver.

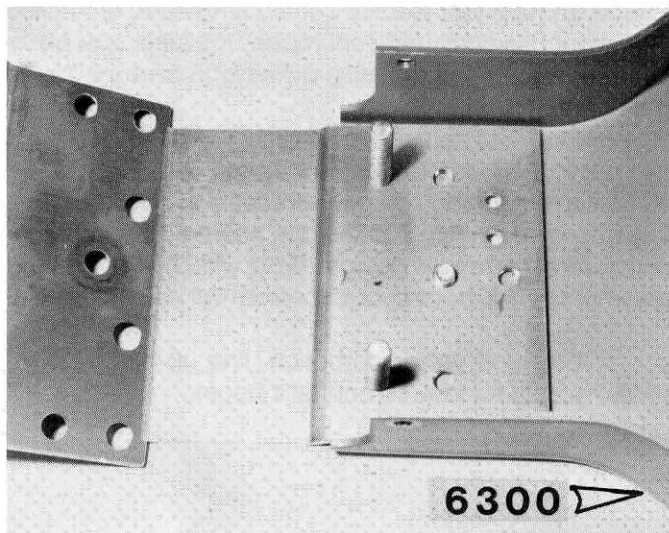

Fig. 2

□ **Fig. 4** Install the #6330 body mount as shown with body clip hole going left to right.

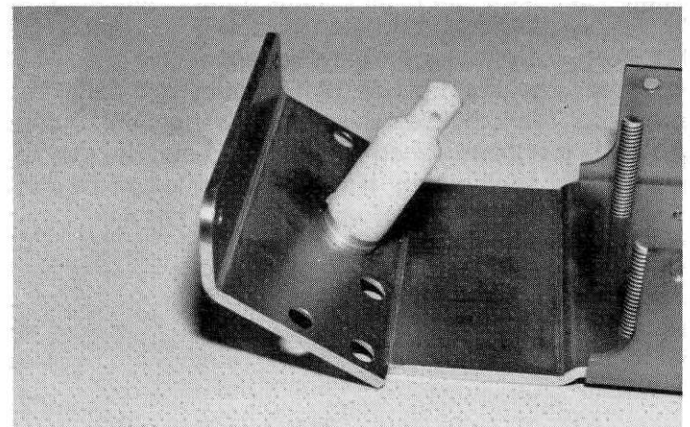

Fig. 4

□ **Fig. 5** From bag #6-1, take out the left hand front suspension mount #6207. This mount will have the letter L on the bottom. The left or right hand side of the car is determined by the driver as he sits in the car. His left hand will be the left side of the car and his right hand the right side.

NOTE: The left and right front suspension mounts are attached together by a thin "runner" that must be removed with scissors or a knife.

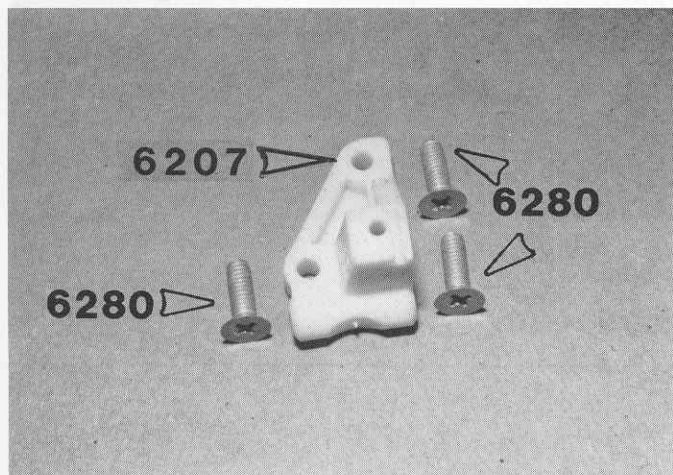

Fig. 5



□ **Fig. 6** Install the L.H. suspension mount, as shown, with the three #6280 8/32 x 1/2" FHMS Phillips screws. Now, install the right hand mount with the same type of screws.

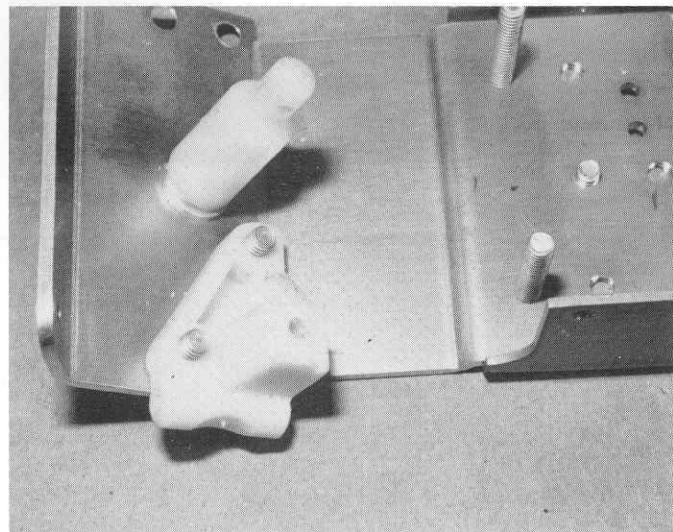

Fig. 6

□ **Fig. 7** From bag 6-1, take out one of the #6206 front A-arms, the #6226 inner pin and the package of "E" clips, as shown.

NOTE: The package of "E" clips is in the form of a "stack" or short roll with white paper glued around the outside (see Fig. 7a). There is a roll of "E" clips in three different bags. You will have more than enough to complete your car. To do the L.H. A-Arm lay it on the table as shown. Slip the pin into each end of the front A-arm #6206 to check the pin fit. The A-arm should be able to swing freely on the pin. Most racers keep a .126" and a .128" reamer in their toolbox to free up A-arms and to clean them after racing. We want the pin to fit tight in the mount #6207.

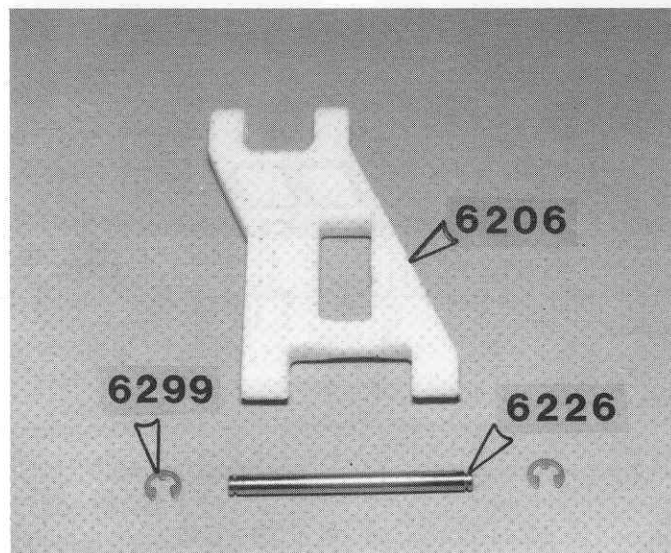

Fig. 7

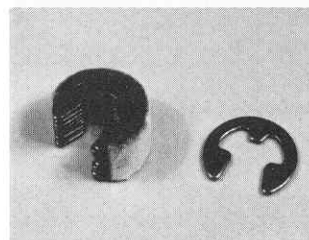
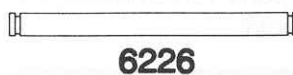

Fig. 7a

□ **Fig. 8** Line up the A-arm with the mount and push the pin through. Using a small screwdriver, install an "E" clip on each end of the pin. Now, install the R.H. side.

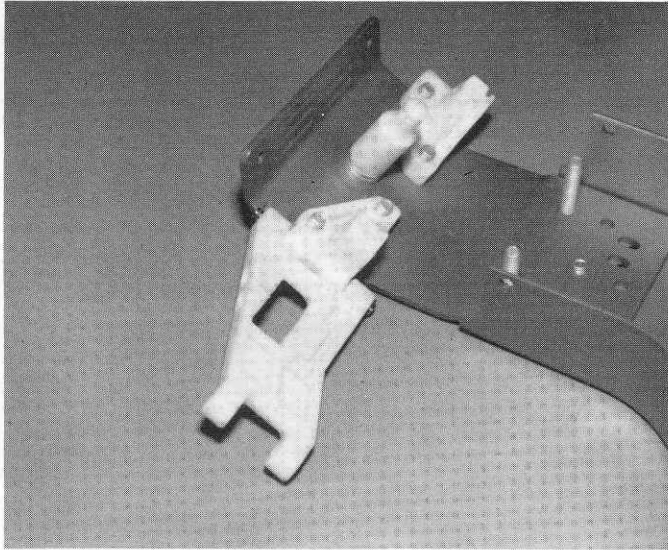

Fig. 8

□ **Fig. 9** From bag #6-14 screw one of the #6273 long ball ends into the #6213 left hand front block carrier #6213 (from bag #6-1). Screw on the #6295 4/40 plain nut and tighten. Assemble the right hand parts, remembering the parts will be the reverse of the photo..

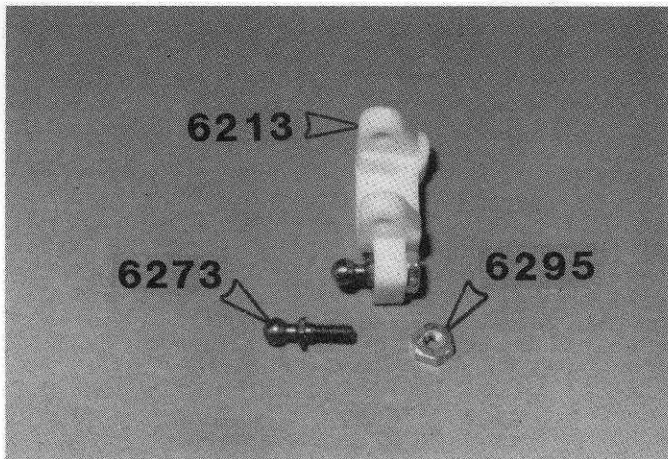
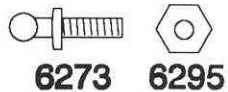

Fig. 9



□ **Fig. 10** Screw the short ball end #6270 (from bag #6-14) into the #6217 steering block (bag #6-1) and secure it with the #6295 4/40 plain nut as shown. Assemble the right hand side, which will be inserted into the opposite side shown in Fig. 10.

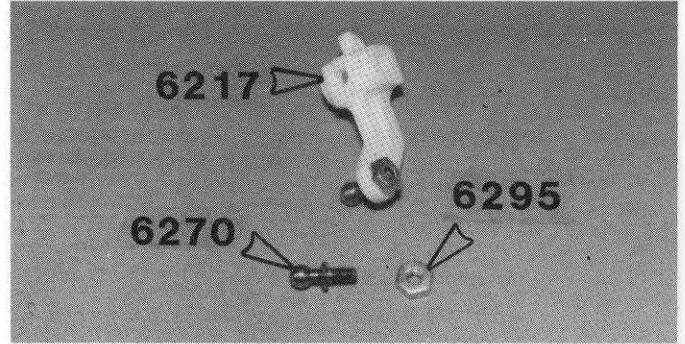
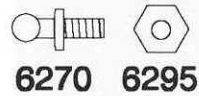

Fig. 10



□ **Fig. 11** From bag #6-1 push the front axle #6218 into the steering block #6217 as shown so the hole in the axle lines up with the hole in the steering block. It may push together with your fingers. If not, LIGHTLY tap it into the hole. Assemble the right hand side in the same way.

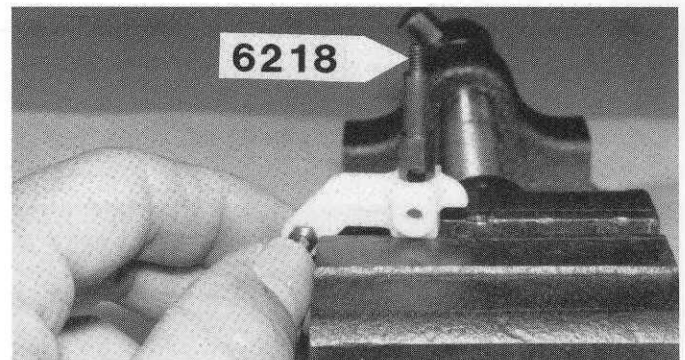

Fig. 11

□ **Fig. 11a** You'll notice that the hex part of the axle does not go all the way into the steering block. That's O.K. Just make sure the hole in the axle is lined up with the hole in the steering block.

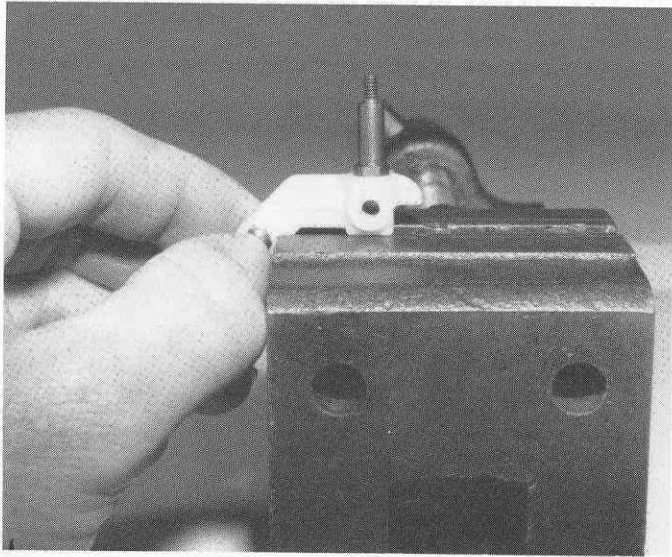

Fig. 11a

□ **Fig. 12 & 12a** Line up the steering block in the block carrier, as shown, and push the #6223 king pin (from bag #6-1) through. Now, install "E" clips on the top and bottom ends of the pin. If you run out of "E" clips, there are extras in the shock bags. Install the R.H. steering block.

The pin will be loose in the block carrier but will be snug in the steering block, so you might have to lightly tap it in.



6223

Fig. 12

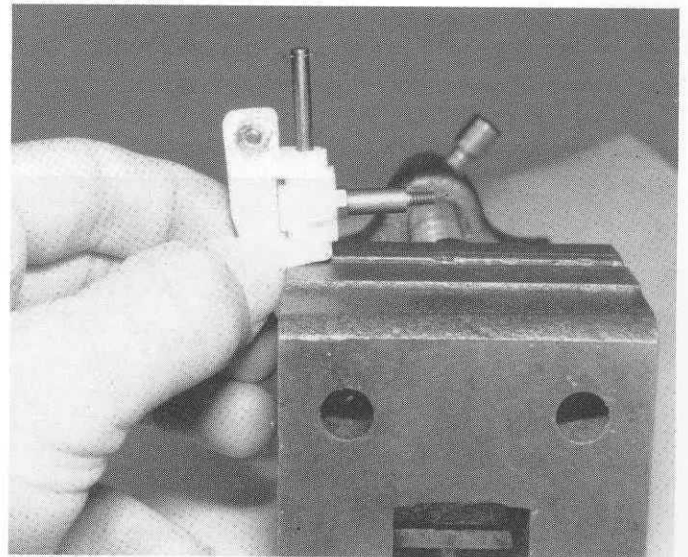
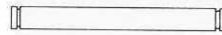
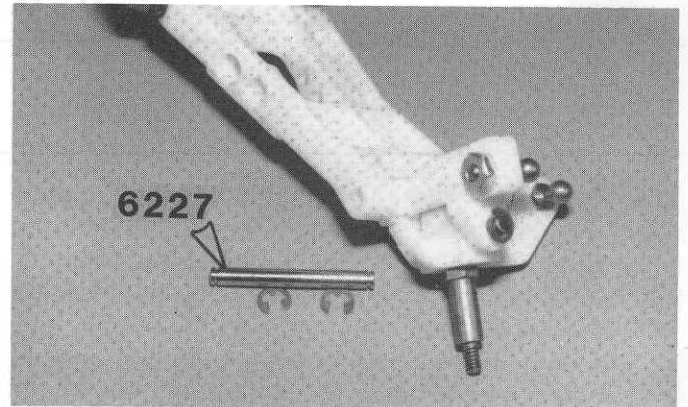

Fig. 12a

□ **Fig. 13 & 13a** Line up the holes in the block carrier with the holes in the A-arm and push the #6227 outer hinge pin (from bag #6-1) into the arm. Install the "E" clips. Do the R.H. side.



6227

Fig. 13

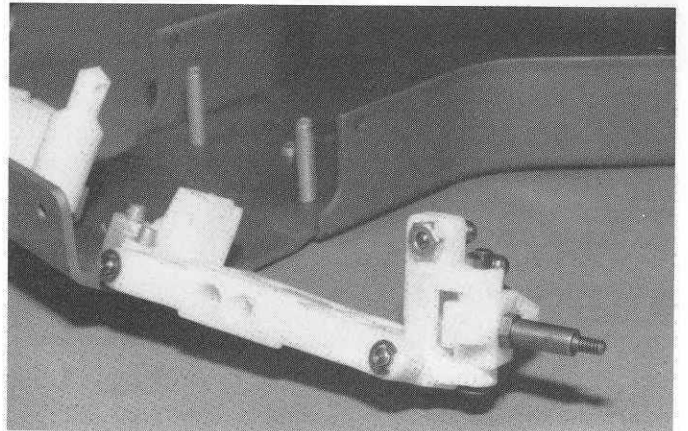

Fig. 13a

□ **Fig. 14** Take the #6231 front shock strut out of the same bag. In bag #6-10 take out two #6927 4/40x 3/4" SHCS screws and install them in the shock strut in the locations shown. **NOTE:** Your shock strut may have six holes, if so, use center hole on top row.

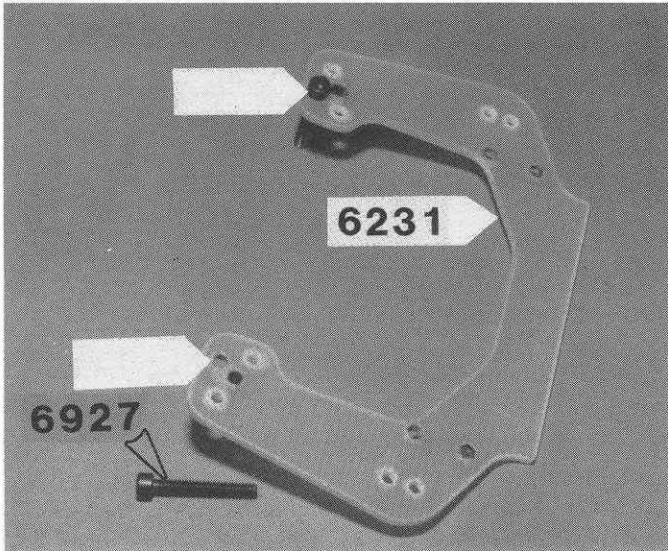

Fig. 14



□ **Fig. 15** From bag 6-1 take the two #6925 4/40 x 1/2" SHCS and mount the shock strut onto the two front suspension mounts. If the holes don't line up, loosen the aluminum screws holding the suspension mounts to the chassis, align the mounting holes and retighten all the screws.

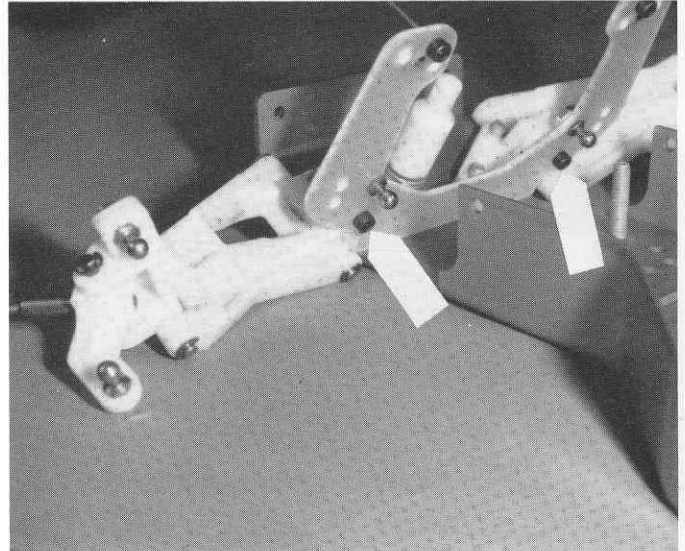
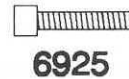

Fig. 15



□ **Fig. 14a** Again from bag #6-14, take two short #6270 ball ends and install them in the shock strut in the locations shown. Then install the two #6295 4/40 plain nuts on the other side. **NOTE:** The balls will be on the same side as the screw heads.

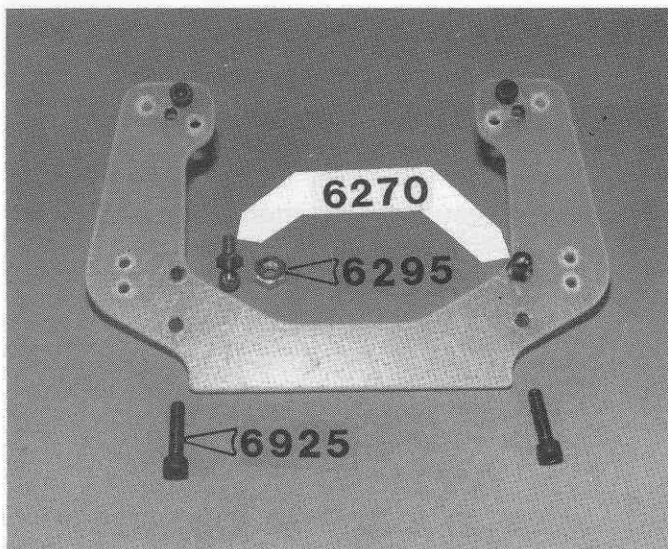
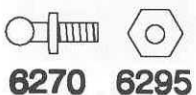

Fig. 14a



□ **Fig. 16** From bag #6-1 take out the two #6262 threaded turnbuckles, and from bag #6-14 take out the #6274 plastic ball cups, as shown. Twist the ball cups and take four of them off. **NOTE:** #6259 is a complete set of replacement turnbuckles and plastic cups for the car.

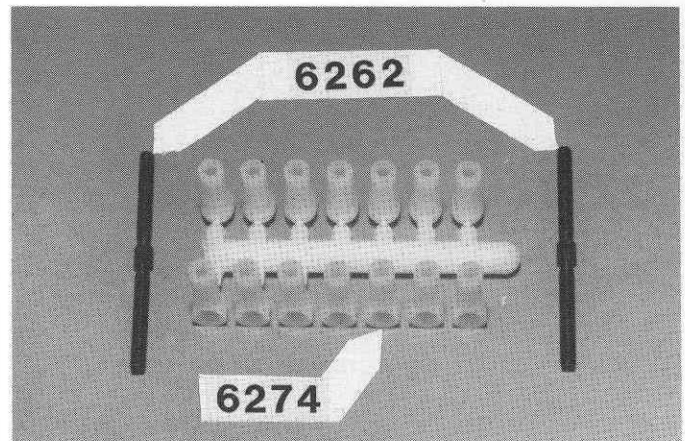

Fig. 16



Fig. 17 Screw the plastic ball cups onto the rods, as shown. The rods have a LH thread on one end and a RH thread on the other end, so they will screw on in different directions. Screw them on evenly to the dimension shown, which is measured from the center of the ball cup. Ball sockets on both ends face the same direction.

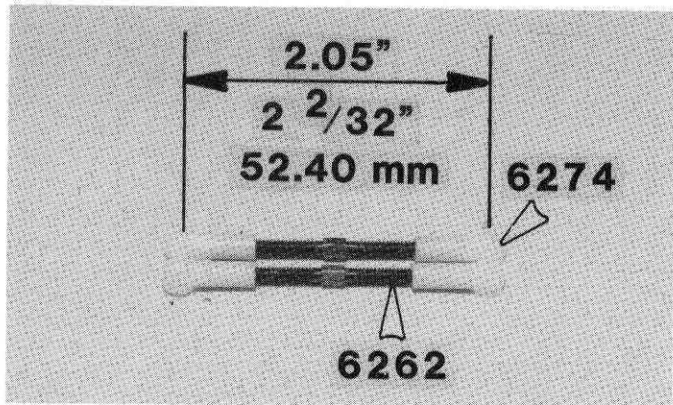

Fig. 17

Fig. 18a The rod ends can be removed quite easily from the balls by holding the rod end with a pliers, as shown, and twisting the rod end off the ball, as shown.

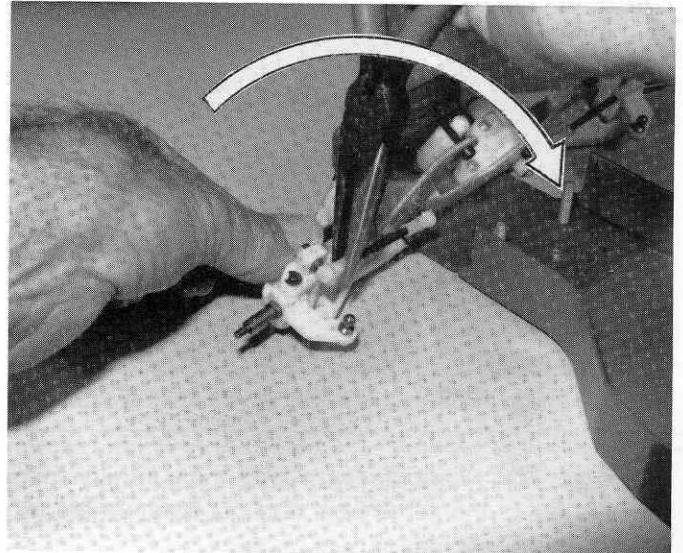

Fig. 18a

Fig. 18 Carefully snap the rods on the metal balls, as shown. You'll probably have to use pliers. Do the R.H. side.

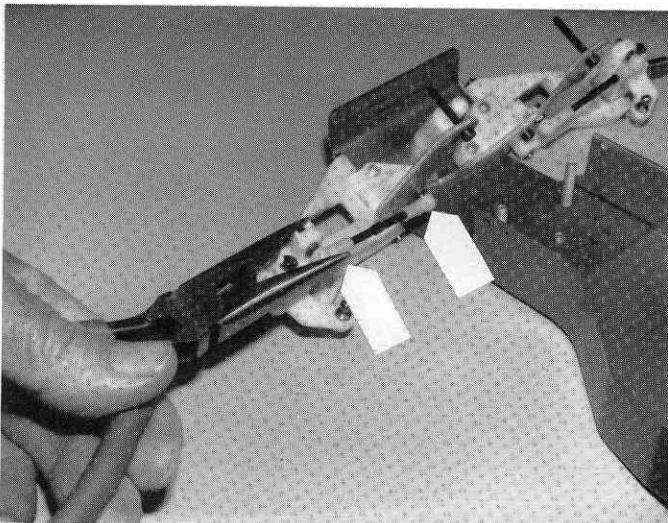

Fig. 18

Fig. 19 In bag #6-2, take the #6255 servo saver parts out, and install four short #6270 ball ends from bag 6-14, as shown. No nuts are needed on these.

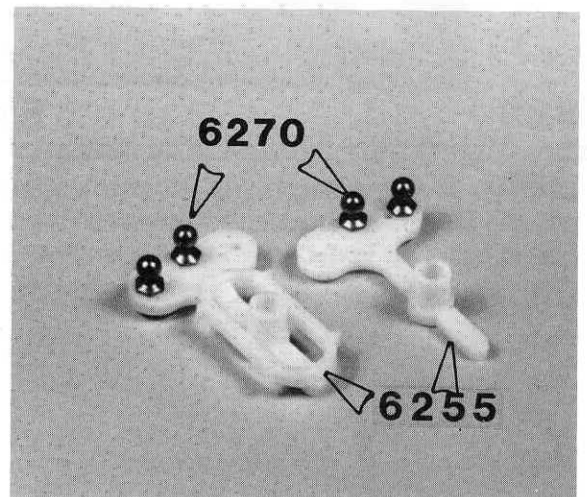

Fig. 19



6270

Fig. 20 Take the servo saver arm from bag #6-2

Fig. 21 And install it to the servo saver, as shown.

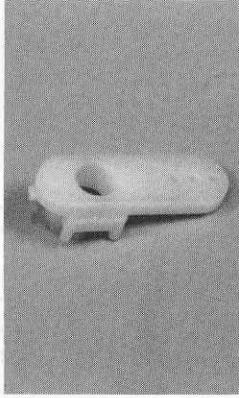

Fig. 20

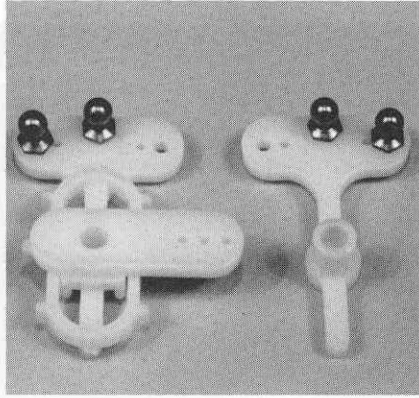
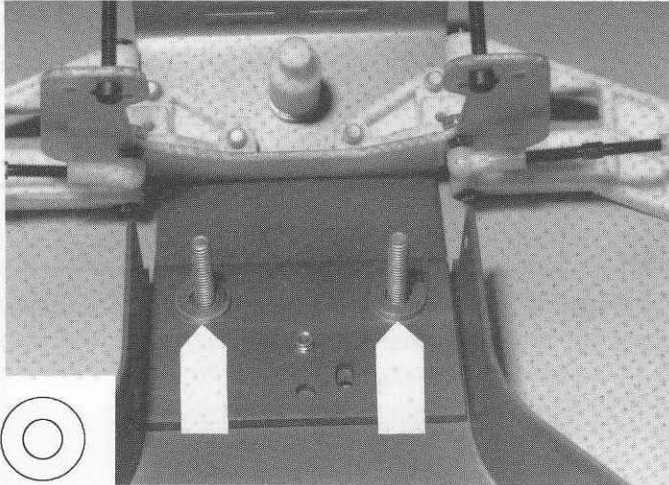

Fig. 21

Fig. 22 Take the two #3323 thick #8 aluminum washers out of the same bag, and put them on the two screws, as shown.



3323

Fig. 22

Fig. 23 From bag #6-2 take the two long #6263 and one short #6260 turnbuckles and screw on the six #6274 plastic ball cups from bag 6-14 to the lengths shown.

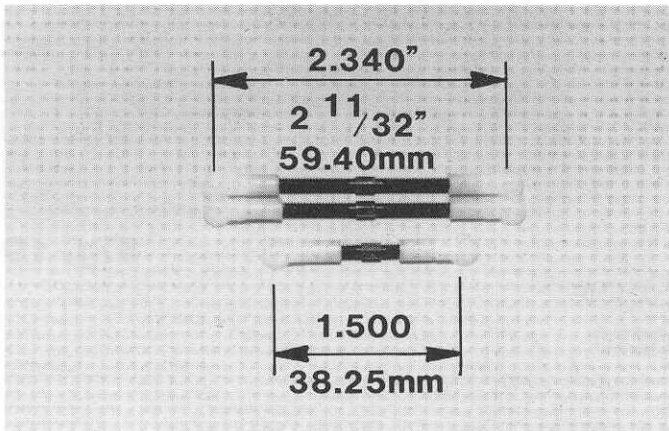

Fig. 23

Fig. 24 Take the short turnbuckle and pop it on the servo saver with a pliers, as shown.

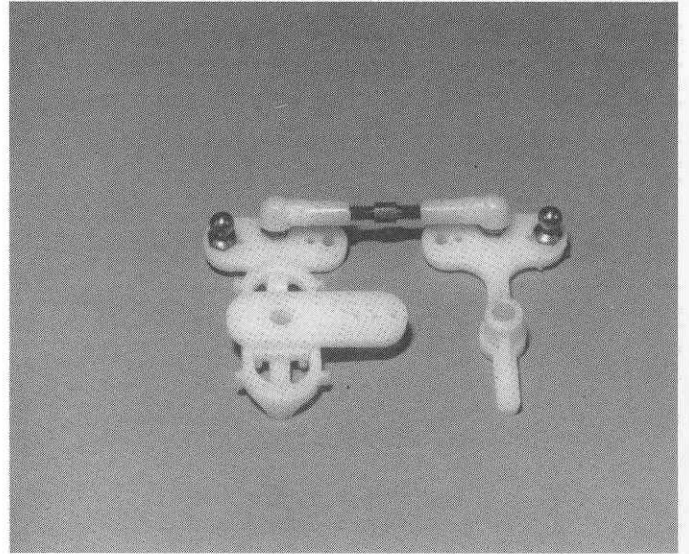

Fig. 24

Fig. 25 Place the servo saver onto the 2 screws, as shown. Take the two #6296 nylon nuts from bag #6-2 and screw them down until the servo saver starts to tighten, then back the nuts off about 1/2 turn until the servo saver arms pivot freely.

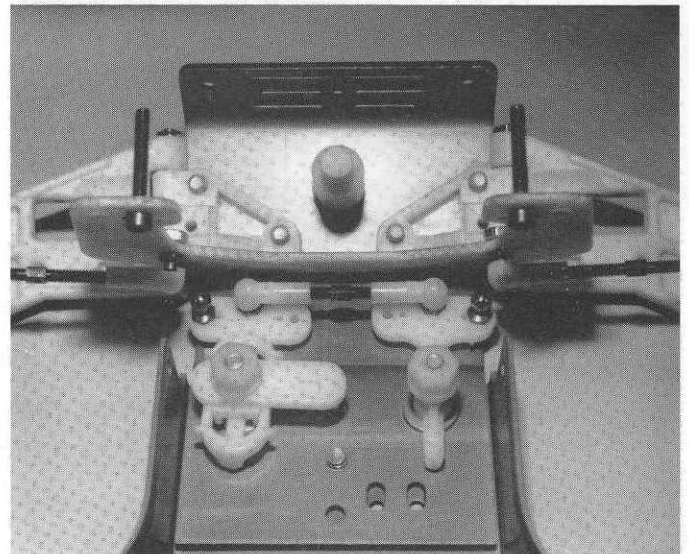

Fig. 25

□ **Fig. 26** Snap the L.H. and R.H. tie rods on, as shown.

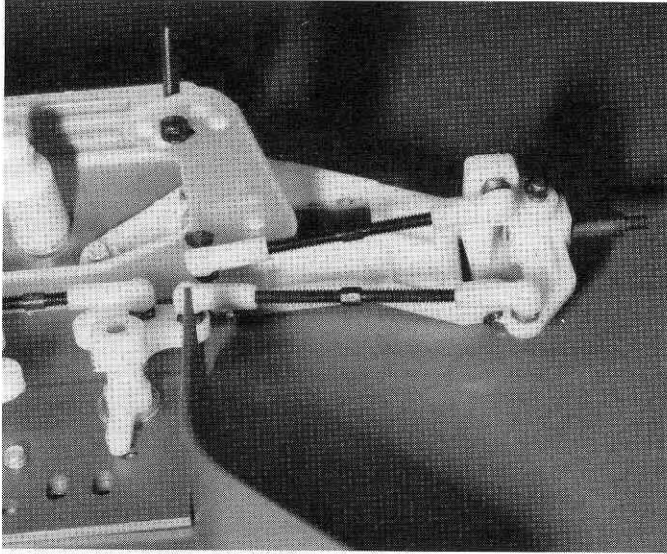

Fig. 26

TEAM ASSOCIATED
STEALTH
A T C TRANSMISSION

Transmission
for the **RC10**

INSTRUCTIONS

Featuring:

- Quick-change spur gear
- Case-to-motor plate dirt-proof seal
- Lightweight design
- Long-life clutch friction plate
- Large area/high torque clutch plates
- Low inertia drive train

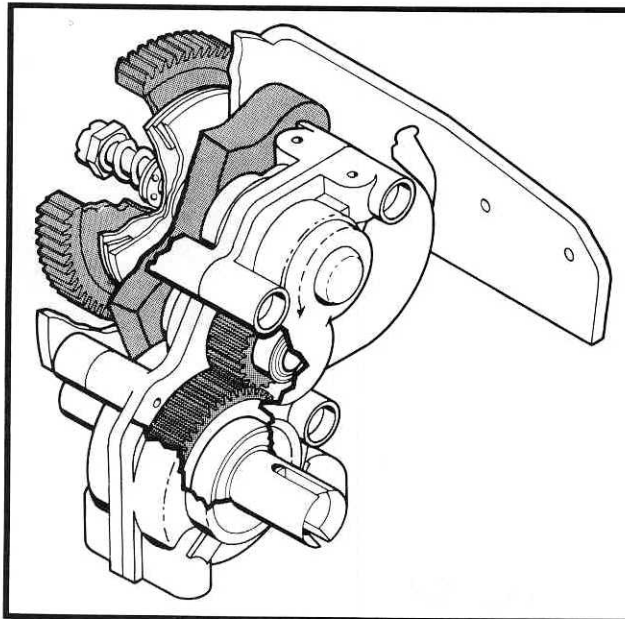

- Precision-molded 48 pitch gears with extra low 2.25 final drive ratio
- Reversible motor mounting
- Gold anodized mounting plate
- Tungsten carbide differential balls
- Bronze bushings
- High torque ball differential

STEALTH TRANSMISSION

We feel this transmission is the best in the world. It has enabled Team Associated to finish 1st, 2nd and 3rd at the World Championships in Australia and 1st, 2nd and 3rd at the ROAR Nationals in Northern California with our RC10 car. With this transmission your RC10 will be much easier to drive, enabling you to cut your lap times by a considerable amount. But it all depends, of course, on how well you assemble and maintain your transmission. So take your time and do it to the best of your ability.

Figs. 27 & 27a Open the Stealth transmission bag. Then start with Bag A, the differential. Take out the #6580 diff gear and the bag with the 12 large #6581 3/32" carbide diff balls. These carbide diff balls are the best there is. They will outlast the diff washers at least 10 times. NEVER replace these balls with any other balls except our #6581 carbide diff balls.

WARNING! Due to precision packaging, when replacing lost or worn 3/32" diff balls, you must replace all 3/32" balls with new balls from same package.

Now take out the #6591 Stealth white silicone diff lube. Another word of caution. DO NOT substitute any other type of diff lube on the balls. It took us countless hours of testing to find the correct silicone diff lube to make the diff work correctly. Do yourself a favor: use what comes in this kit!

Trim any excess flash off the inside of the gear.

Fill the holes in the gear with the silicone diff lube and then push the 12 carbide balls into the holes. Wipe the excess lube back into the ball holes with your finger.

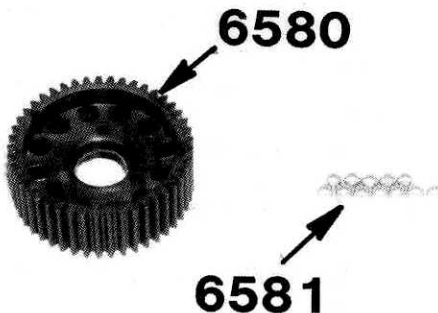

Fig. 27



Fig. 27a

Fig. 28 Your gear.

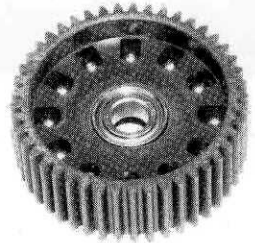

Fig. 28

Fig. 29 Clean all the silicone grease off your hands and push one of the #6597 5/32 x 5/16 bushings from bag B into the center of the #6580 gear. **CAUTION:** there are three bushings that have the same outside diameter, but different hole sizes. Make sure you use the #6597 bushing that fits onto the left hand hub, as shown.

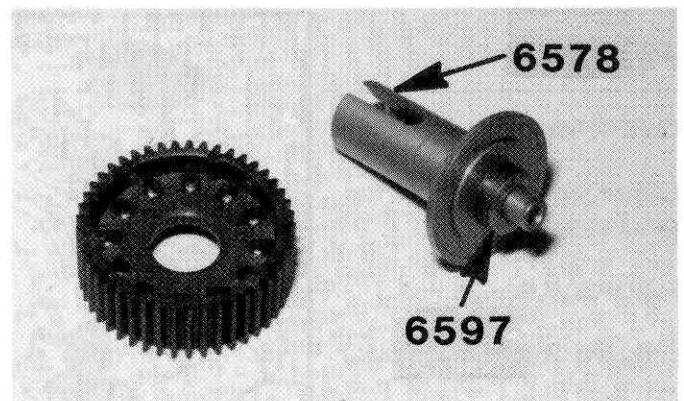

Fig. 29



Fig. 30 Your completed gear.

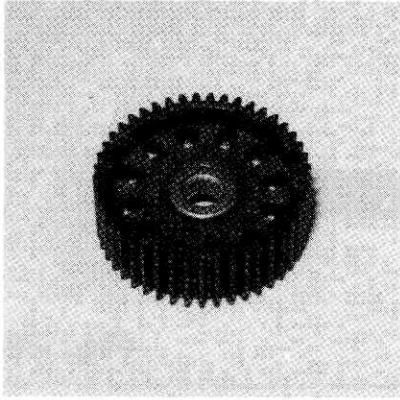

Fig. 30

Fig. 33 Take an Exacto knife and trim off any of the plastic T-nut that extends outside of the slot, as shown.

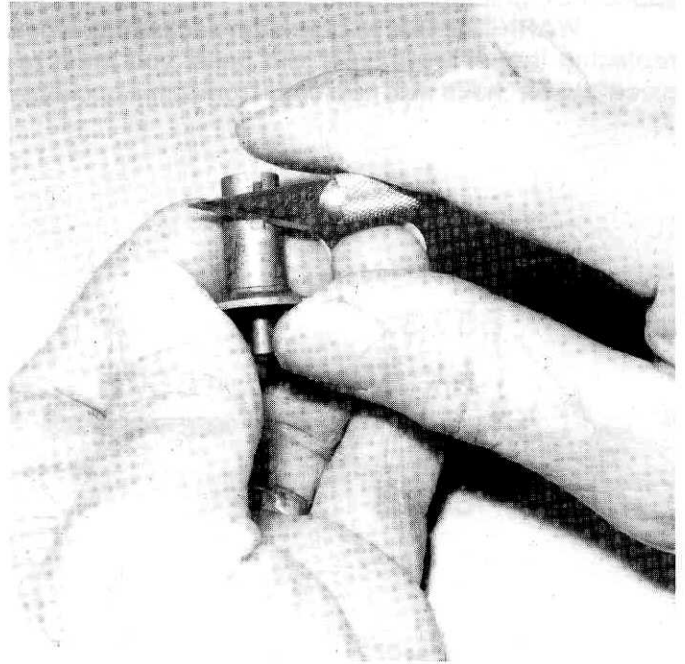

Fig. 33

Figs. 31 & 32 From bag A take out the #6578 left hand diff outdrive hub and **make sure it's clean and free from all burrs**. Push the #6582 diff thrust spring into the hub and then align the plastic T-nut with the slots in the hub and push the T-nut all the way in against the spring.

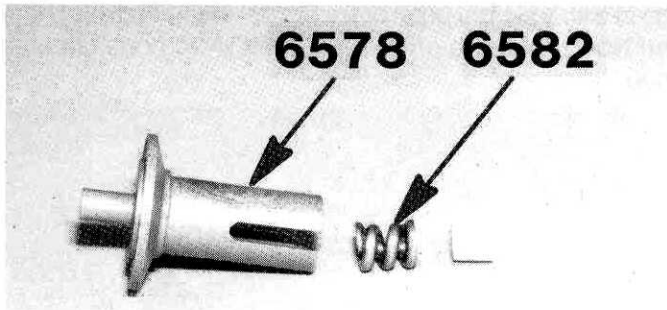

Fig. 31

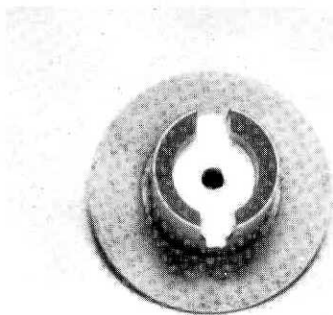

Fig. 32

Fig. 34 There should now be approximately a $3/32$ " or $.100$ " gap where shown.

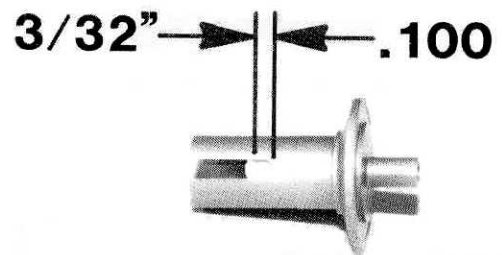

Fig. 34

□ **Fig. 35** Still using bag A take out the #6575 diff thrust bolt, the two #6573 diff thrust washers, and the six #6576 5/64" precision thrust balls.

WARNING! Due to precision packaging, when replacing lost or worn 5/64" diff balls, you must replace all 5/64" balls with new balls from same package.

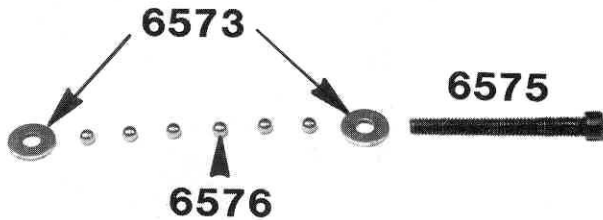

Fig. 35

□ **Fig. 38** Now take the balls and place them all around the bolt between the two washers. The grease will hold them in place.



Fig. 38

□ **Figs. 36 & 37** Slip the two washers on the bolt, as shown, and then fill the area between them with the #6588 black grease. DO NOT use the black grease on the diff balls in the gear.

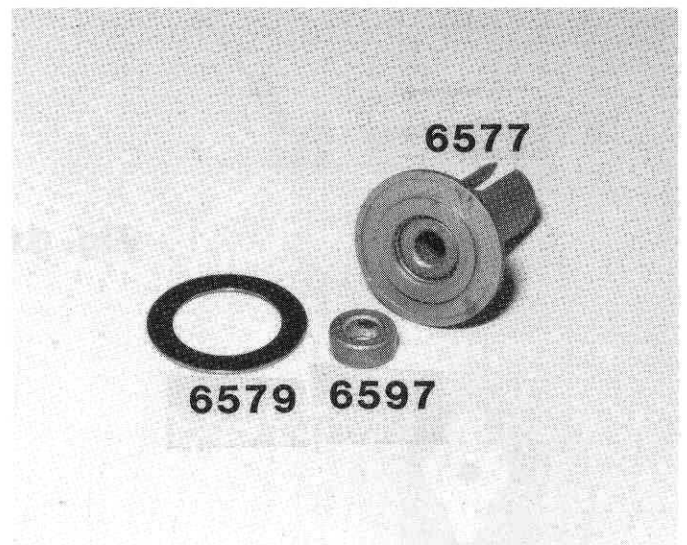

Fig. 36



Fig. 37

□ **Fig. 39** From Bag A take the #6577 right diff outdrive hub and **make sure it's clean and free of all burrs**. From Bag B take the second and remaining #6597 bushing and install it in the right hub. The bushings must go in with a simple push of your finger. **NEVER drive them in!** Now place one of the #6579 diff drive rings onto the hub.



6597

Fig. 39

□ **Fig. 40** Your hub should look like this. DO NOT try to pin the drive ring to the hub. The hub is designed to lock the drive ring without pinning. Leave AS IS.

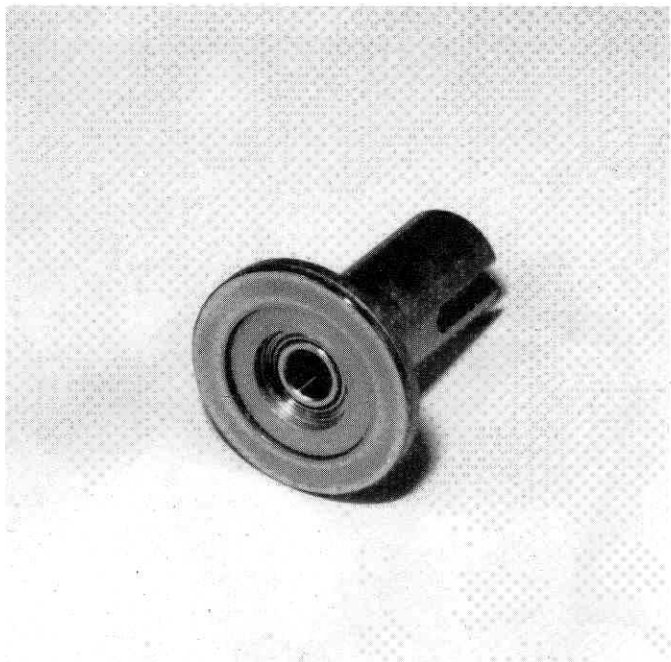

Fig. 40

□ **Fig. 42** Turn the assembly upright. Make sure the #6579 drive ring is still ON and centered. Slip the #6580 diff gear with bushing onto the bolt as shown.

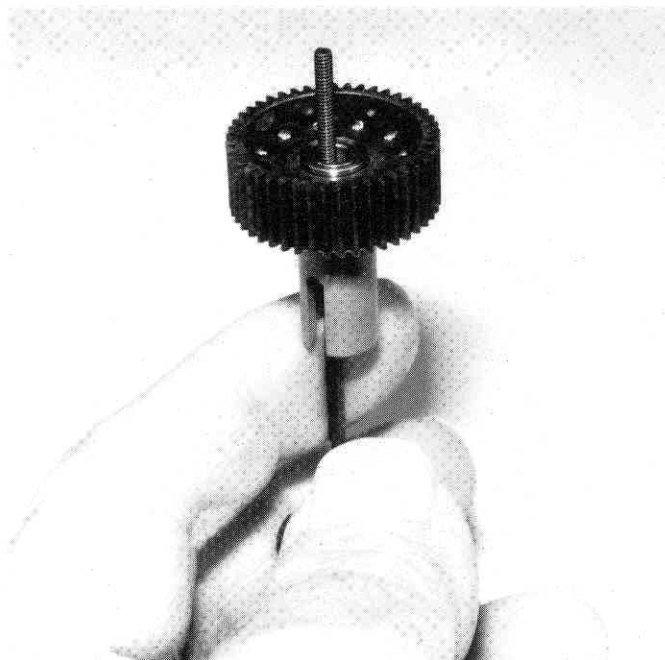

Fig. 42

□ **Fig. 41** Slip the 5/64" Allen wrench into the #6575 diff thrust bolt head. Now slip the bolt assembly through the #6577 right hand hub.



Fig. 41

□ **Fig. 43** Now place the other drive ring onto the diff balls and center it as close as possible to the gear.

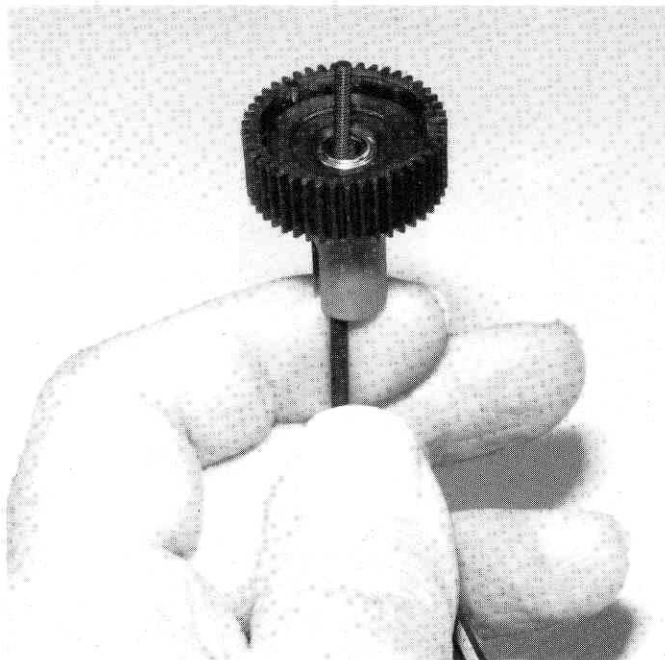

Fig. 43

□ **Figs. 44 & 45** Slip the #6578 left hand hub down onto the bolt, making sure the hub centers itself onto the drive rings. **THIS IS IMPORTANT.**

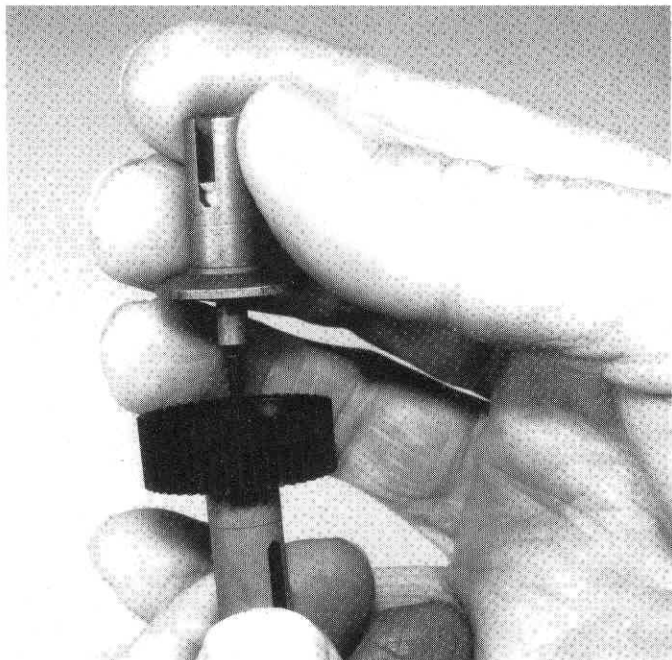

Fig. 44

□ **Fig. 45** Now start to tighten the bolt with the Allen wrench, making sure the hubs and drive rings stay centered. Do this very slowly. We want to make sure everything stays centered. We'll finish the tightening in the next step with figs. 46 & 47.

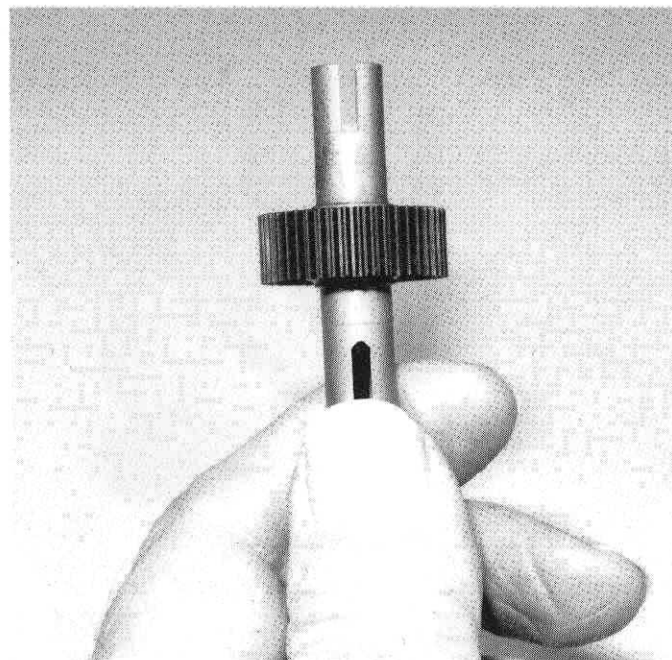

Fig. 45

□ **Figs. 46 & 47** Continue tightening slowly until the spring is completely collapsed. **DON'T OVER-TIGHTEN!** Correct adjustment is bottoming the spring and then backing off 1/8 to 1/4 turn.

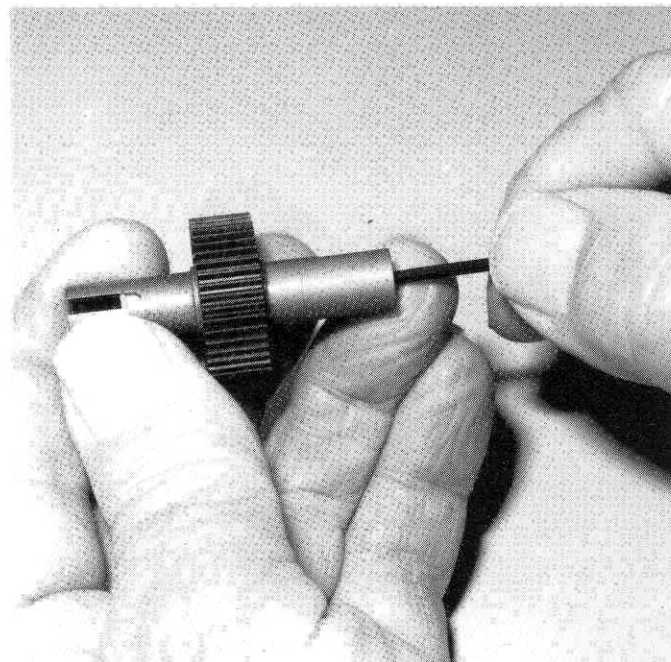

Fig. 46

□ **Fig. 47** As you're tightening, you'll notice the ear on the T-nut, shown by the arrow, moving closer and closer to the bottom of the slot in the hub. The spring should bottom out about the same time as the ear is at the bottom of the slot. When you feel the spring bottom out, that's when you back off 1/8 to 1/4 turn and your diff is correctly adjusted. The diff should operate very smoothly when turning the hubs in opposite directions. They are not supposed to spin freely, but just roll smoothly. Recheck the adjustment before driving the car. There is never a need to adjust the diff in any other manner.

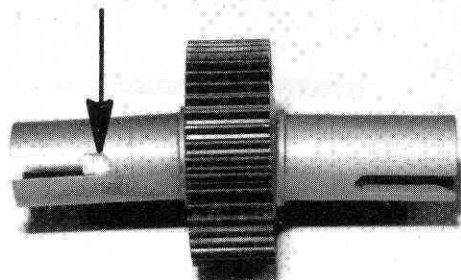

Fig. 47

□ **Fig. 48** Open Bag C and remove the #6565 left and right hand transmission cases (tranny cases), and remove any flash left from molding. Then install the four #6864 upper and two #6598 lower bushings.

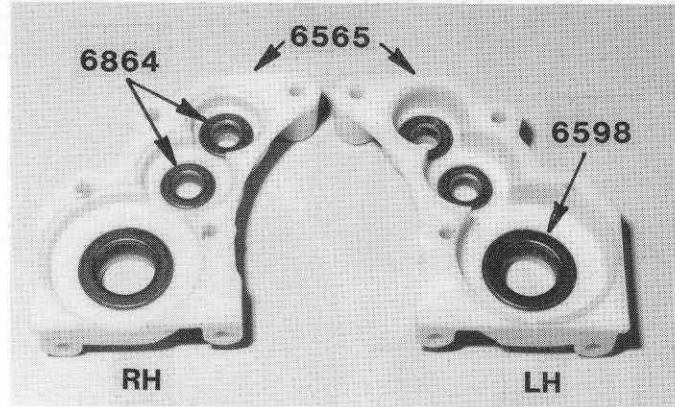
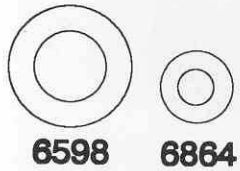

Fig. 48



Take out the #6572 roll pin.

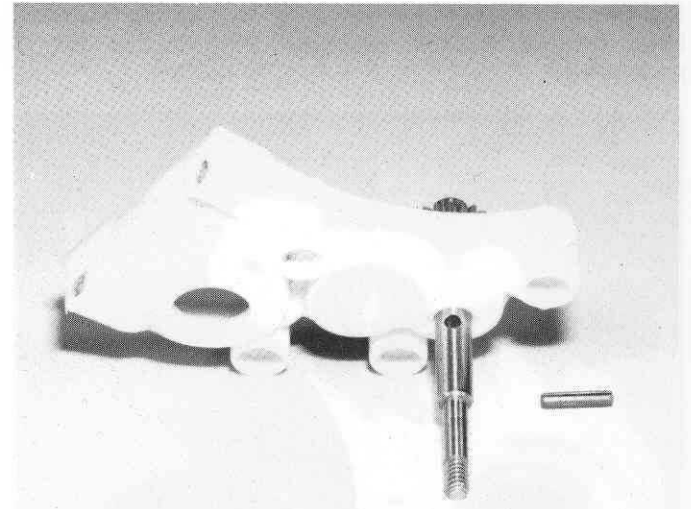

Fig. 50

6572

□ **Figs. 49 & 50** Open Bag D and remove the #6571 drive gear assembly and slide it into the upper bearing in the right hand gear case. It may be necessary to deburr the pin hole to clear the bushing.

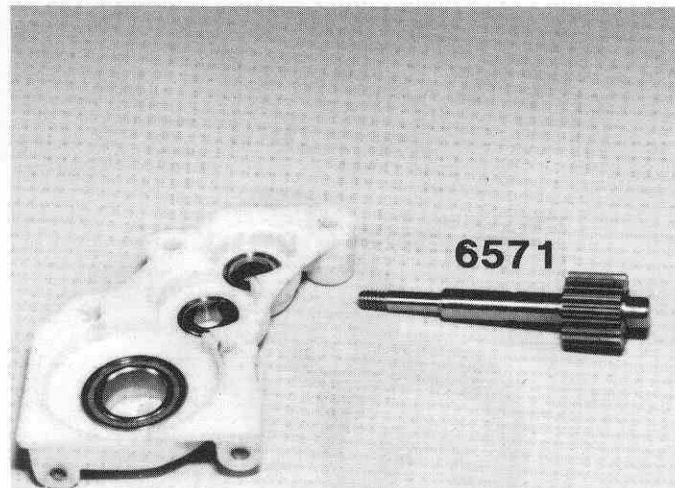

Fig. 49

□ **Fig. 51** Open Bag E and using a pliers, squeeze the roll pin into the hole in the shaft until it is equally spaced.

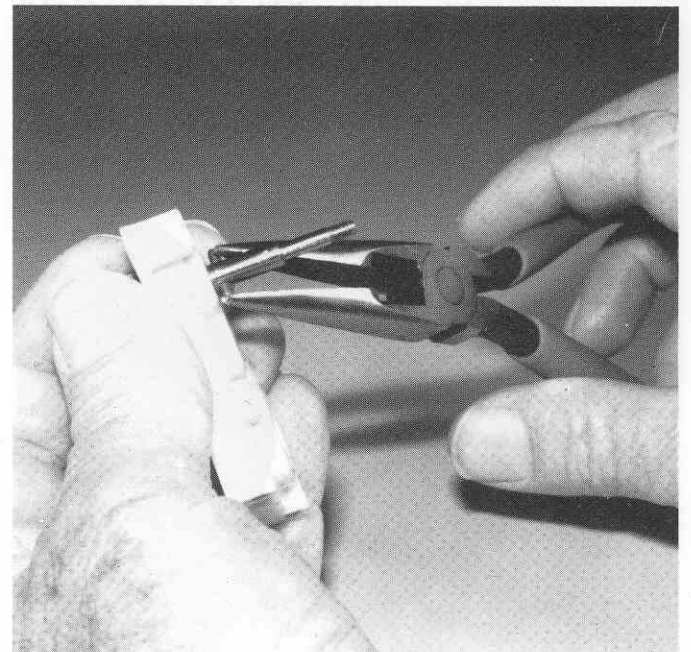

Fig. 51

□ **Figs. 52 & 53** Now take the diff assembly and slip it into the lower big bushing into the right hand case. Insert the right hand hub, which is the one that has the bolt HEAD in it.

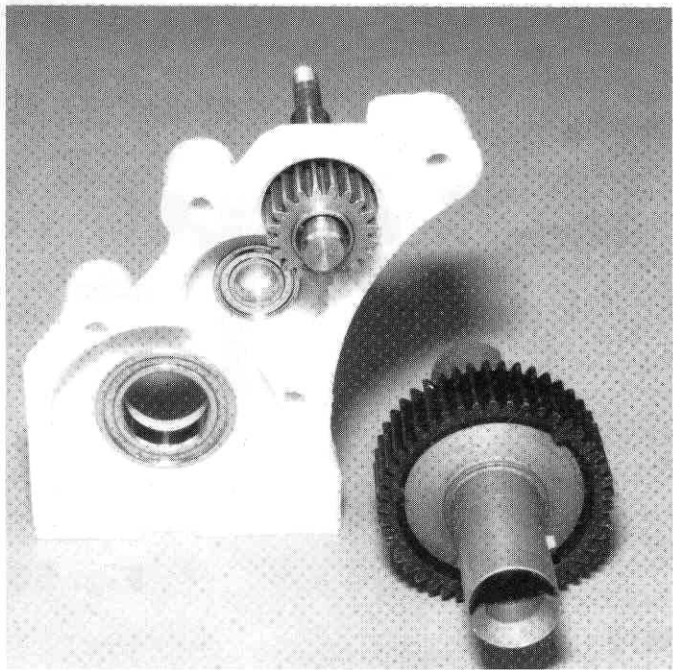

Fig. 52

□ **Fig. 54** Now carefully slip the #6570 from Bag D idler gear into the center bushing.

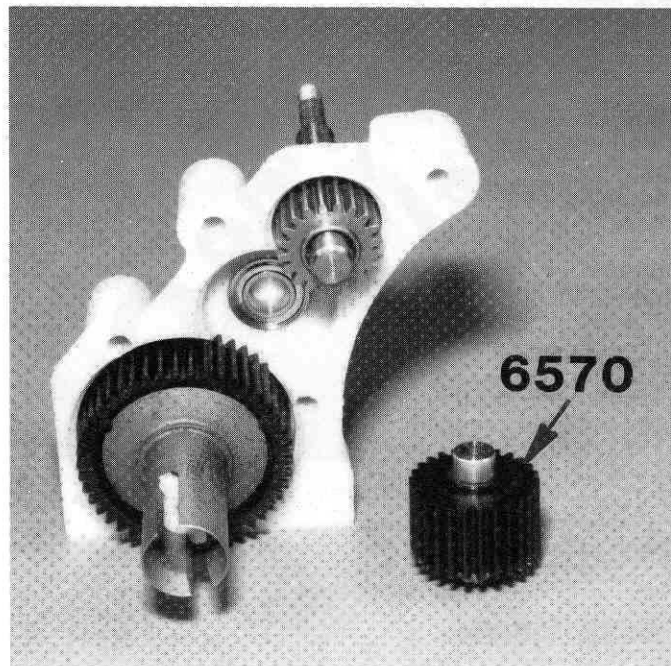

Fig. 54

□ **Fig. 55** The inside of your tranny should look like this. Slip the left hand side of your tranny onto the right hand side.

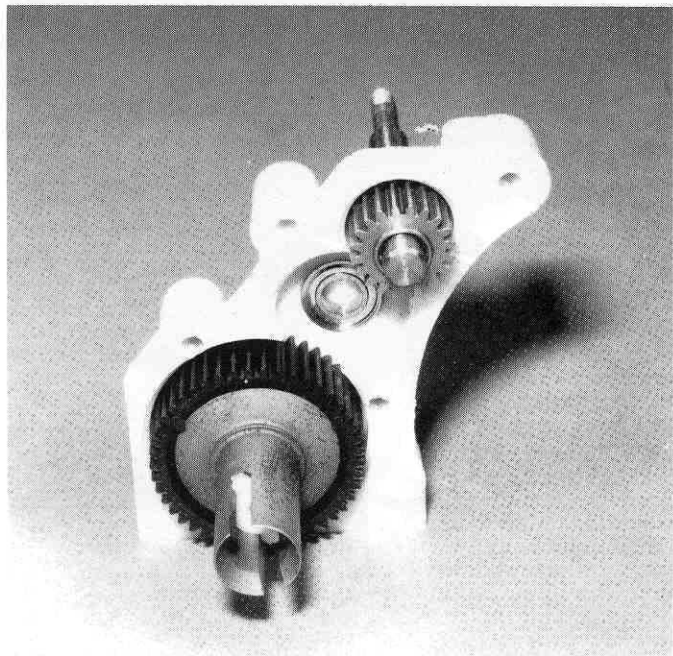

Fig. 53

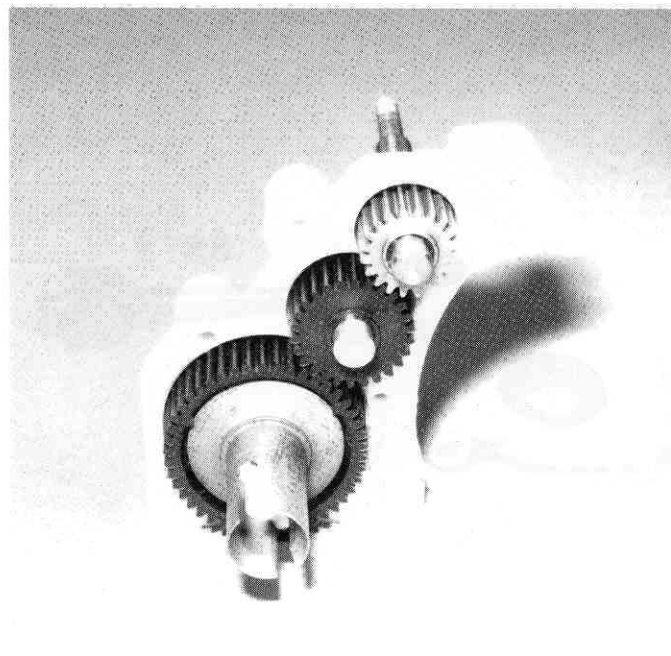
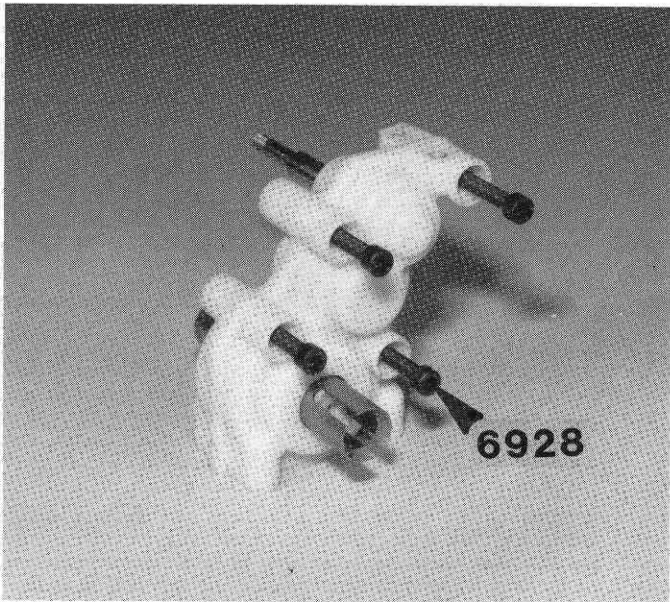
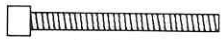

Fig. 55

□ **Fig. 56** From Bag F put the four #6928 1" Allen head case bolts into the case from the left hand side. You'll have to screw them in. Screw in the bolts so they extend about 1/8" on the other side. (Note: #6567 is a complete replacement screw set for the Stealth transmission.)



6928



6928

Fig. 56

□ **Fig. 58** Slip the felt dust shield on the three bolts as shown and slip the fourth plastic spacer on the other bolt.

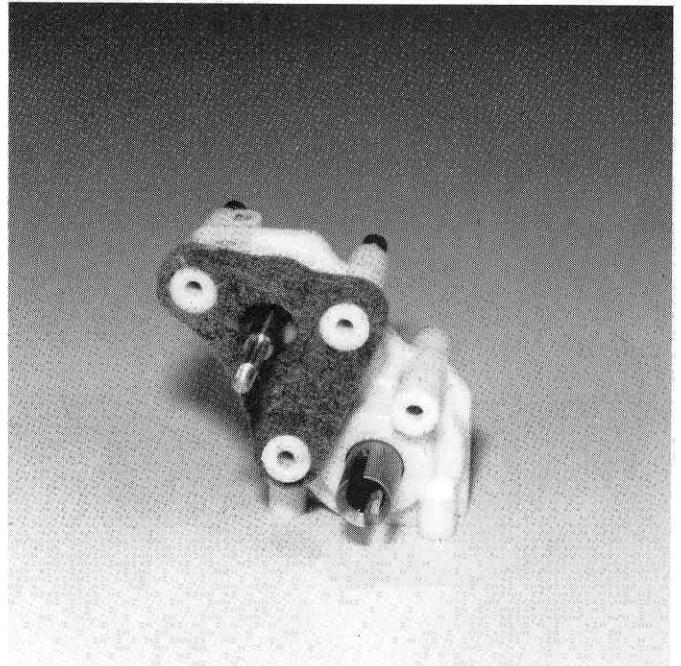
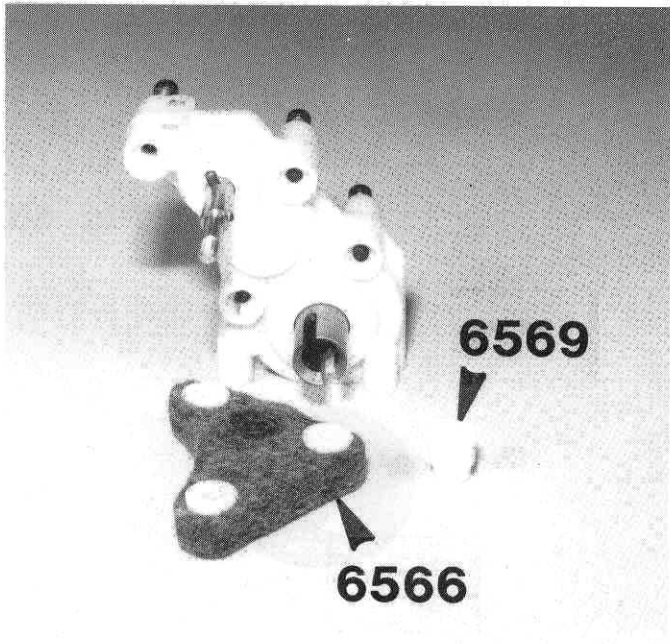

Fig. 58

□ **Fig. 57** Now from Bag C take the four #6569 plastic spacers and slip three of them into the #6566 felt dust shield from Bag F so that the small end of the spacers can go into the case holes.



6569

6566

Fig. 57

□ **Fig. 59** Now take the #6607 gold motor mount (in the tranny bag) and bolt the tranny to it in the location shown and tighten the four bolts. Then install the small plastic dust cap (in Bag C) in the case, where the arrow indicates.

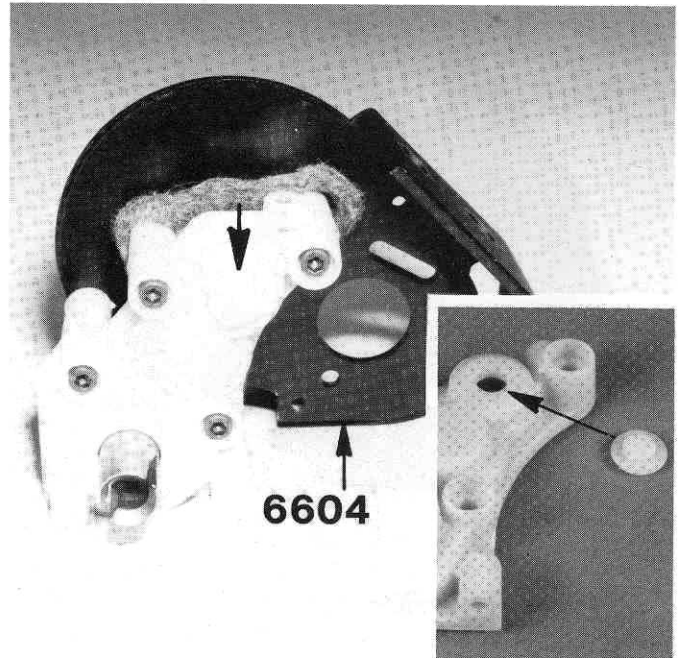

6604

Fig. 59

Fig. 59A

□ **Figs. 60, 61 & 62** Now we'll assemble the clutch Torque Control assembly. Slip the #6583 inner clutch hub in Bag E onto the shaft, making sure the slots align with the pin.

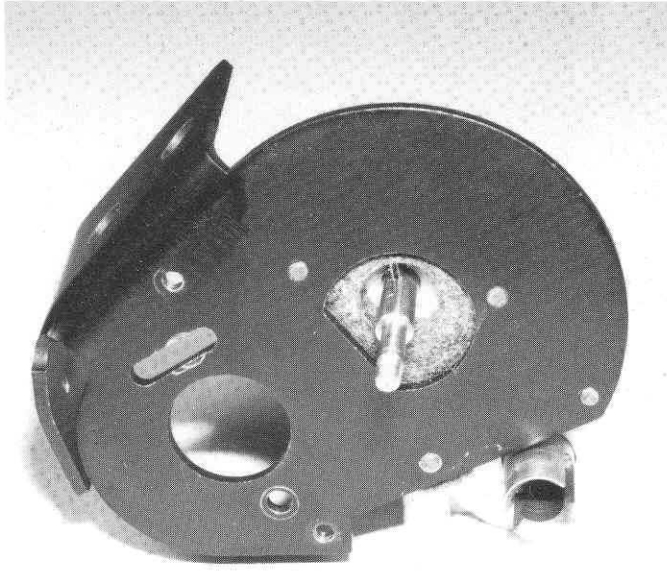

Fig. 60

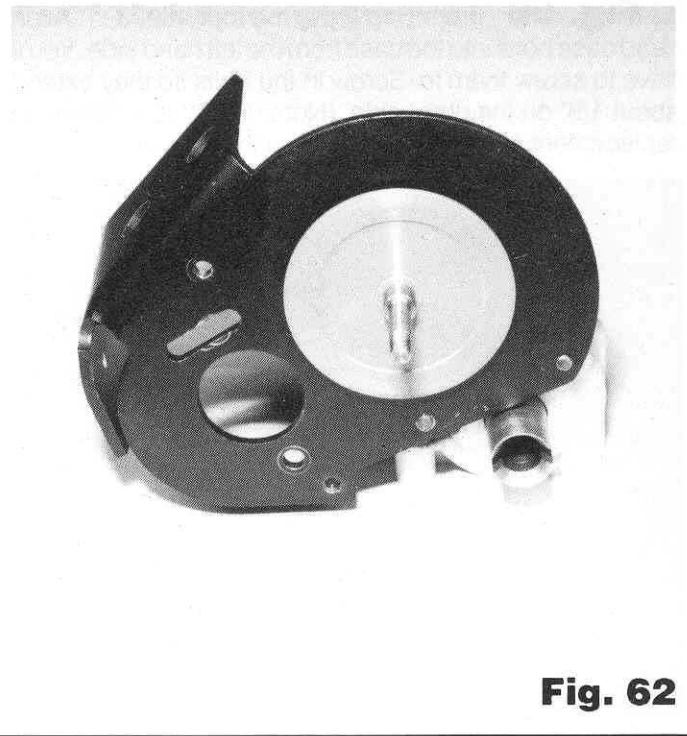

Fig. 62

□ **Figs. 63 & 64** Position the #6585 clutch disk (also in Bag E) so it's centered onto the #6584 outer hub, as shown.

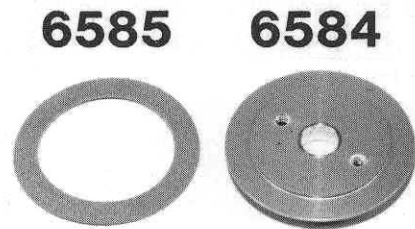

Fig. 63

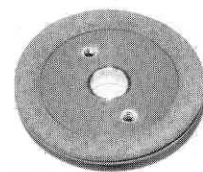

Fig. 64

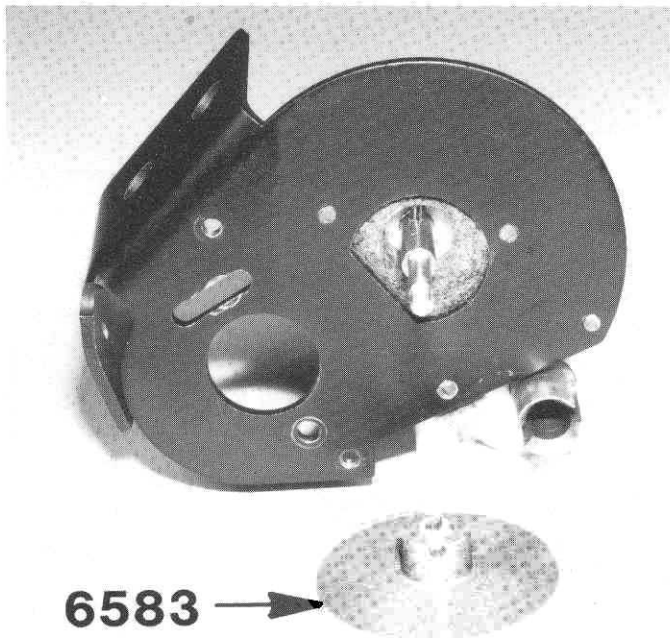

Fig. 61

□ **Fig. 65** Now we'll be assembling these parts, in the order shown in the photo, onto the #6571 shaft. First, install the #6596 3/16" x 5/16" bushing from Bag B into the clutch hub. Now slide the hub onto the shaft, making sure the clutch disk stays centered on the hub.

From Bag E install one of the #6586 thrust washers, then the thrust bearing and the other thrust washer. (NOTE: when servicing this thrust bearing you can use a **very little** of the #6588 black grease.)

Now slip the #6587 spring on and start the 5/40 nut on both from Bag E). Tighten the nut until about 1/2 thread is showing outside the nut. This is a good starting point for the clutch adjustment. If the bushing in the clutch hub will not slip onto the shaft, then you have not used the correct bushing described in fig. 29a. Disassemble the diff and install the correct bushing.

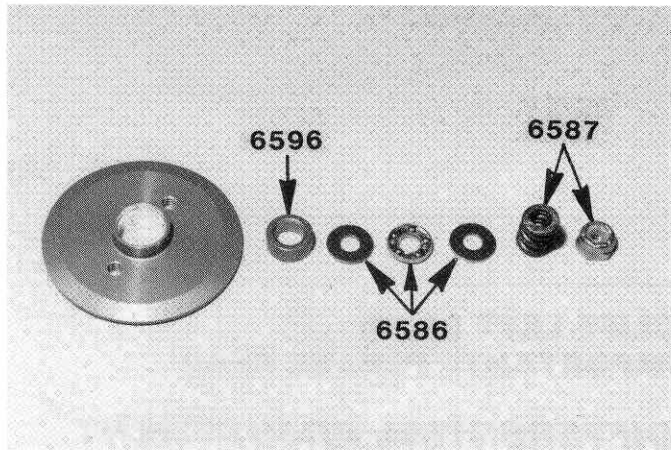

Fig. 65



6596

□ **Figs. 66 & 67** Now open Bag #6-15 and remove the #6693 81 tooth 48 pitch spur gear. Deburr the center hole of the spur gear. Failure to do this can prevent the gear from sitting flat and will cause gear wobble. Mount the gear to the hub using the two #6568 4/40 x 3/16 BHSS mounting screws from Bag F. Try to tighten the screws with equal pressure.



Fig. 66

□ **Fig. 67** From Bag A of Stealth tranny, locate the #6575 diff bolt thrust cover. This looks like a short T-nut without the threaded insert (see drawing below). Insert the thrust cover into the right diff outdrive (covers Allen bolt head) on the passenger (or right side) of car.

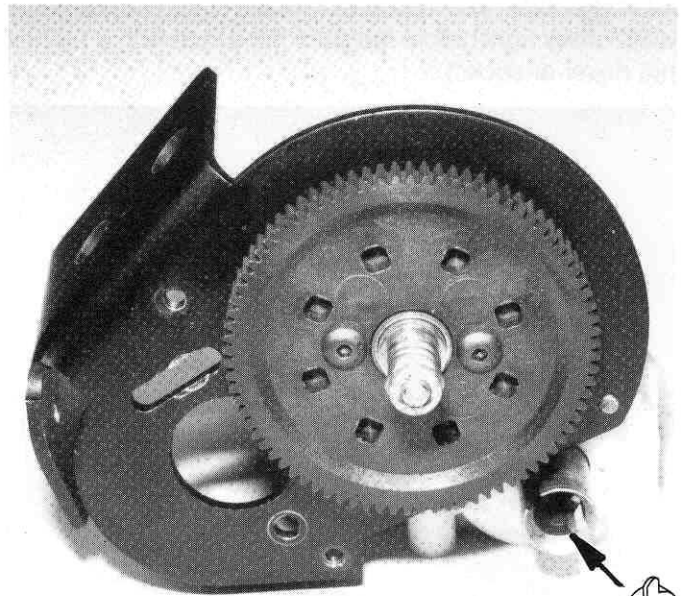

(NOT ACTUAL SIZE)

Fig. 67

Fig. 68 From the Stealth tranny bag remove the #6608 plastic gear cover. Cut out the center button hole and the two mounting holes with an X-acto knife. Trim the outside edge of cover to match the photo. Mount the cover using two #6285 4/40 x 1/4 SHCScrews and one #6936 #4 aluminum washer. The washer goes on lower mounting screw.

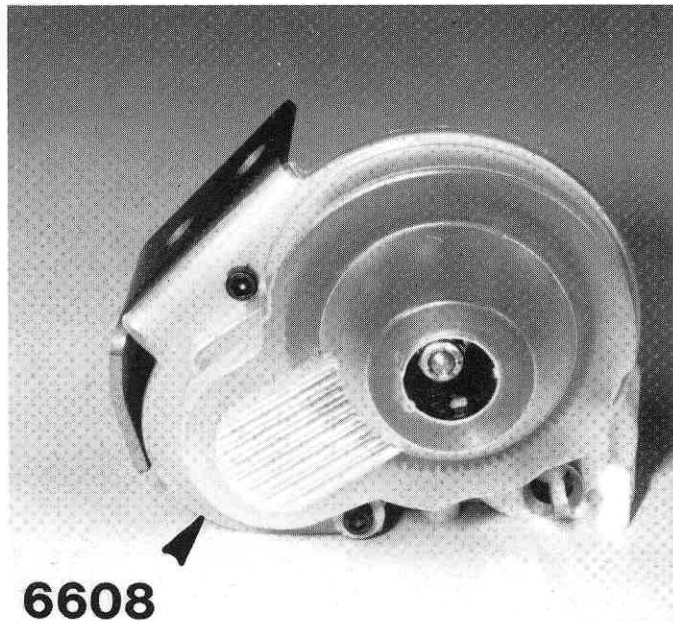

Fig. 68



Fig. 70 Make sure you put the black button on the cover to keep the dirt out.

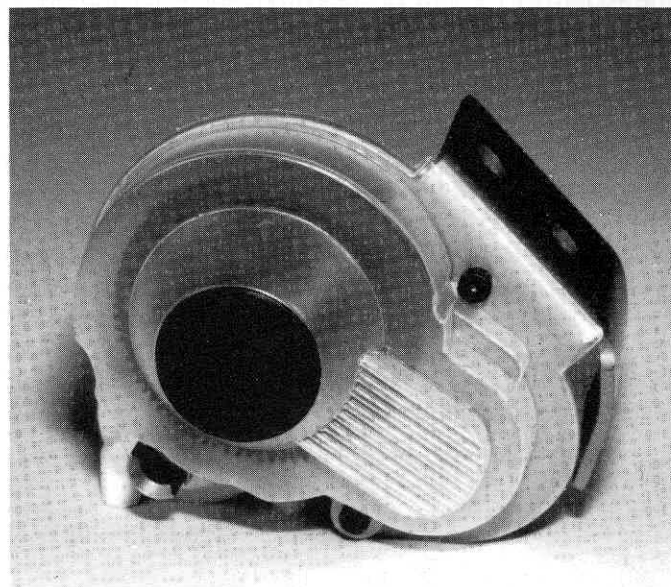

Fig. 70

**CLIFF LETT SAYS:
IMPORTANT-- PLEASE READ**

DIFFERENTIAL ADJUSTMENT

Once the differential has been correctly adjusted there should be no need to change it until rebuilding time. **Be very careful when bottoming the spring during adjustment and extremely accurate when backing the screw out 1/8 to 1/4 turn. This is the most important adjustment in the transmission.** When you've made all of the necessary adjustments and the car is ready to run (battery and motor included), apply a small amount of throttle while holding one of the rear wheels stationary. Do this for about 15 seconds. This will correctly seat all of the differential parts. Now re-check the diff adjustment.

You should rebuild the differential when the action gets somewhat "gritty" feeling. Usually cleaning and relubing the diff will bring it back to new condition. The 3/32" tungsten carbide and 5/64" precision balls should very rarely need changing. However, the large and small thrust washers should be checked regularly.

TORQUE CLUTCH ADJUSTMENT

It is very easy to over-tighten the torque clutch. If you do, you may damage the differential. Therefore take your time and allow the clutch disk to properly seat before adjusting to race setting. This is done by running the torque clutch adjustment a little on the loose side for about one minute. Remember that the purpose of the clutch is to gain traction, not break the tires loose.

Fig. 69 You'll be able to make clutch adjustments quite easily right before the start of the race with a 1/4 hex nut driver or socket.

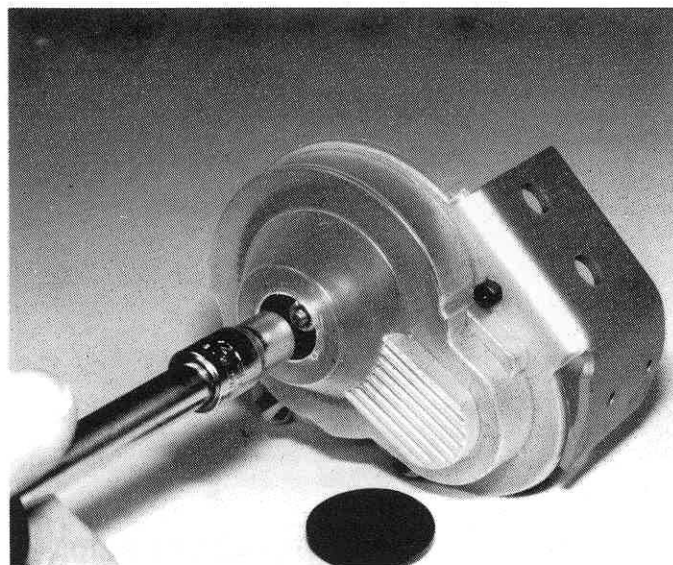

Fig. 69

REAR END ASSEMBLY

□ **Fig. 71** From bag #6-4 take the #6323 rear bulkhead out, and the 2 #6327 wing tubes. The wing tubes are the short tubes. Take the tubes, round off the square cut corners on the ends with a file, and tap the wing tubes into the bulkhead.

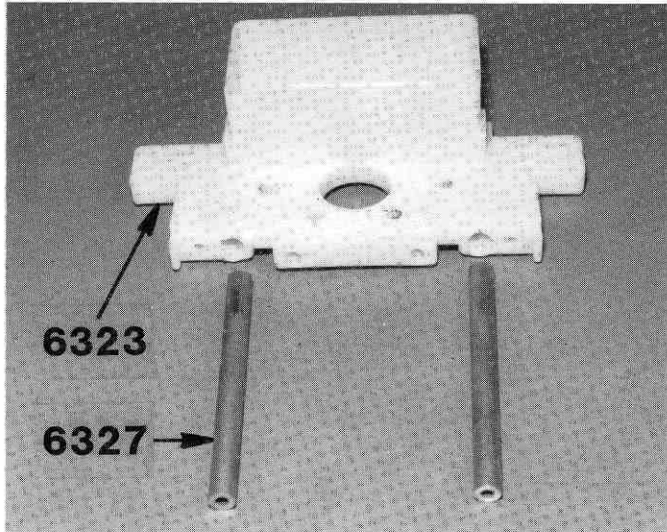

Fig. 71

6327

□ **Fig. 72** From the same bag, take two #6280 8/32 x 1/2" FHMS Phillips screws and attach the bulkhead to the chassis, but DO NOT tighten the screws all the way down yet, but almost tight. Then install the two #6925 4/40 x 1/2" SHCS Allen screws, as shown, but do not tighten these down yet. We'll be tightening these four screws down later.

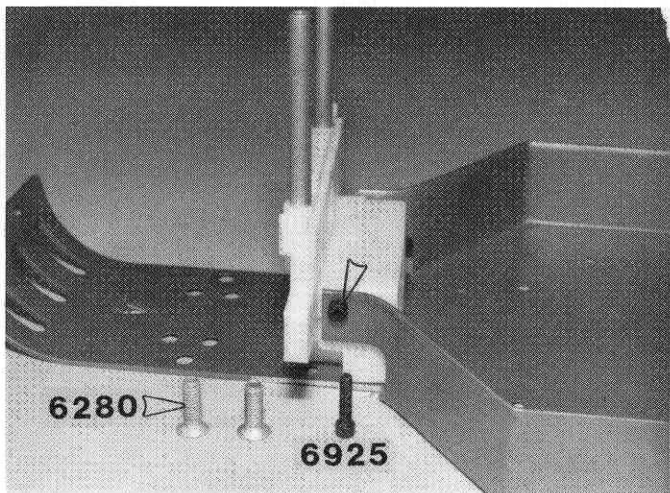
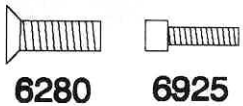

Fig. 72



□ **Fig. 73** Install two #6273 long ball ends from bag 6-14 into the upper, inner holes, as shown, below the wing tubes. Tighten them all the way down.

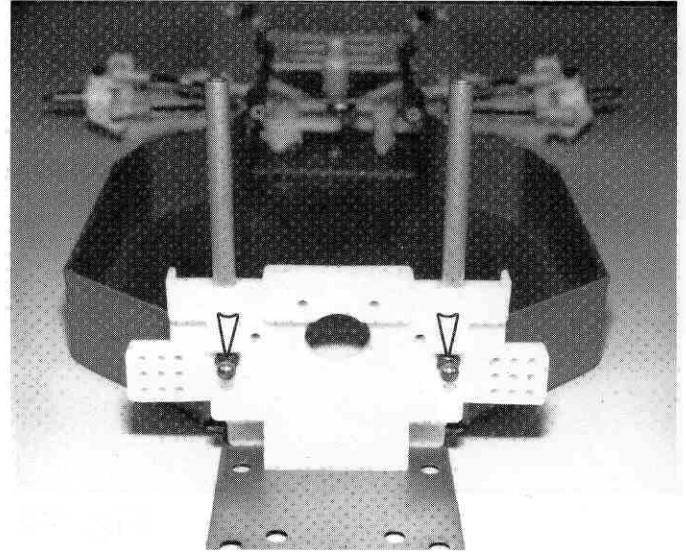

Fig. 73



□ **Fig. 74** Take the assembled Stealth tranny and install it with four #6292 4/40 x 3/8" FHSS screws from the Stealth tranny Bag F. Do not tighten the screws all the way yet. Be sure the motor mount plate is INSIDE of the chassis at the back, as shown.

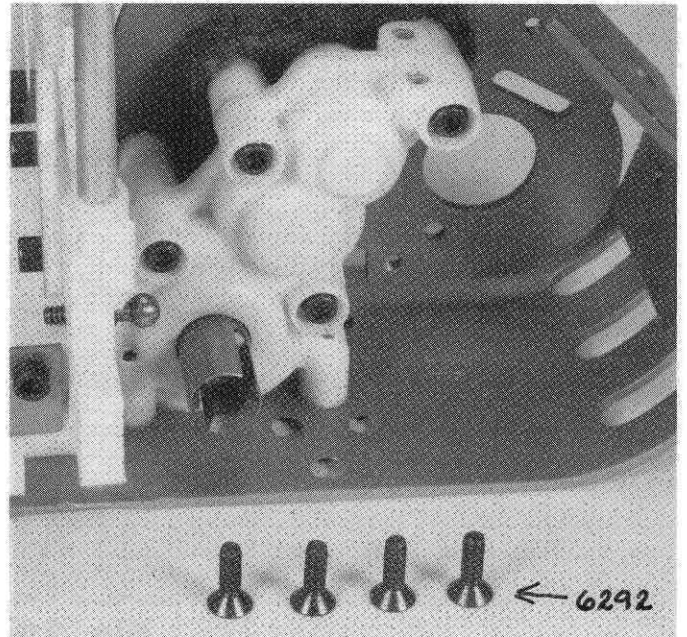

Fig. 74



□ **Fig. 75** These 6 screws should be loose yet.

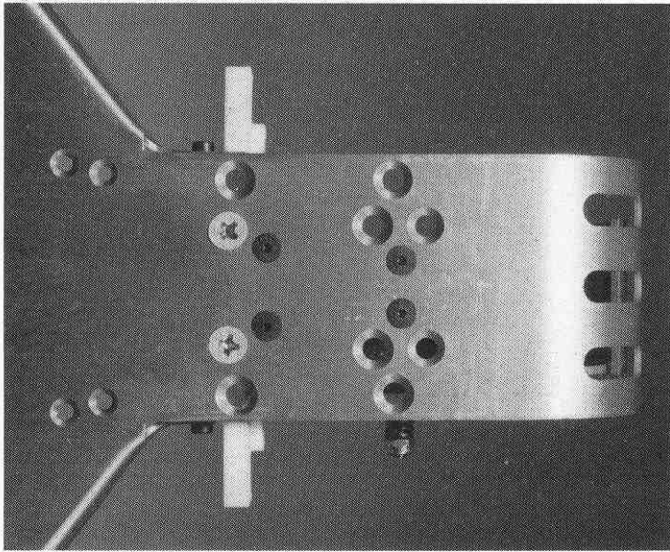

Fig. 75

□ **Fig. 77** Install the transmission brace with the body mount closer to the bulkhead. Use the two 4/40 x 1/2" SHCScrews and two #4 washers on bulkhead mounting holes and two 4/40 x 5/16" SHCScrews with #4 washers on transmission mounting holes as shown. Do not tighten down all the way yet.

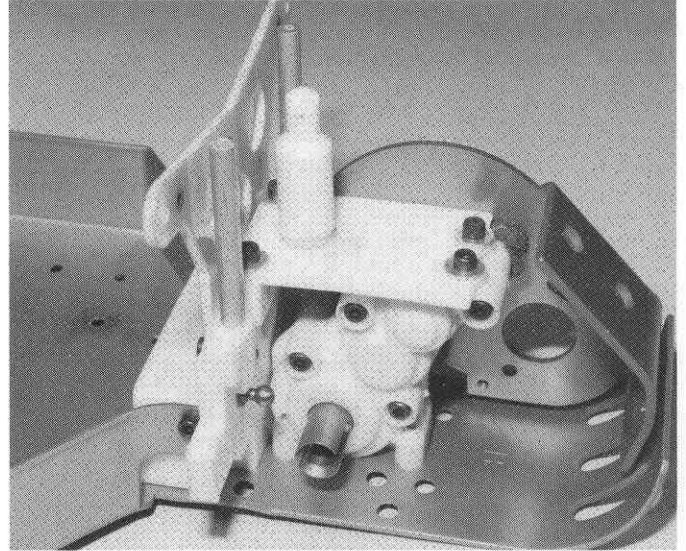
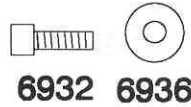

Fig. 77



6932 6936

□ **Fig. 76** Take the #6325 transmission brace out of bag #6-4, the rear #6330 body mount from bag #6-5, one #3323 #8 thick aluminum washer, and one #6280 8/32 x 1/2" aluminum FHMScrew. Slip the 8/32 screw through the brace. (One side of brace is countersunk for screw head.) Place #8 washer over screw and thread on body mount until tight. From bag #6-4 take two #6925 4/40 x 1/2" SHCScrews, two #6932 4/40 x 5/16" SHCScrews, and four #6936 #4 washers.

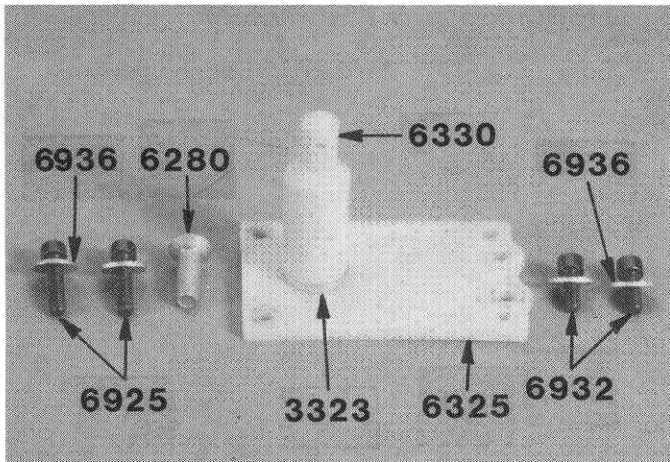
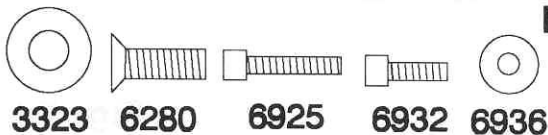

Fig. 76



3323 6280 6925 6932 6936

□ **Fig. 78** Attach the rear of the chassis plate to the motor mount with two short #6285 4/40 x 1/4" SHCS Allen screws from bag #6-4 and tighten down. Now go back and tighten down all the screws in photos #72, 74, 75, and 78. Be careful when tightening screws into plastic. As soon as they feel like they're starting to tighten up **STOP** so you don't strip out the plastic.

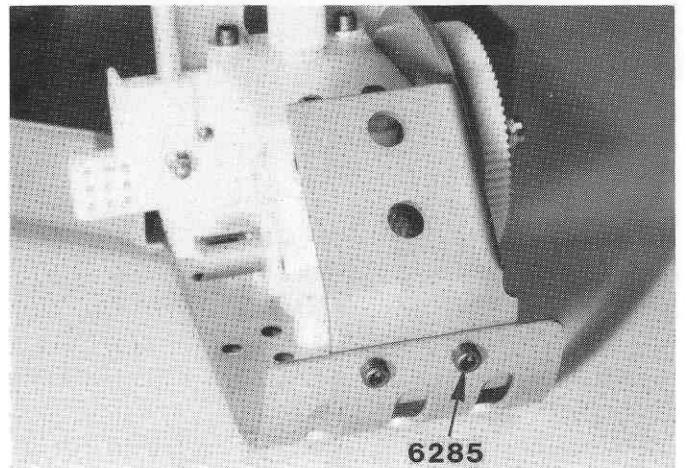

Fig. 78



6285

□ **Fig. 79** In bag #6-8 you will find the #6360 rear suspension mounts, #6355 rear A-arms, and two #6380 inner hinge pins. Take the left hand mount (with the "L" on the bottom), the left hand A-arm and one hinge pin. Line up the holes in the arm and mount and install the pin. Install two e-clips, one on each end. The pin should be loose in the arm but tight in the mount. Assemble the right hand arm.

NOTE: The left and right rear mounts are attached together by a thin "runner" that should be removed with scissors.

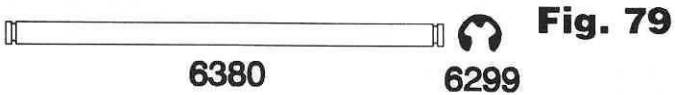
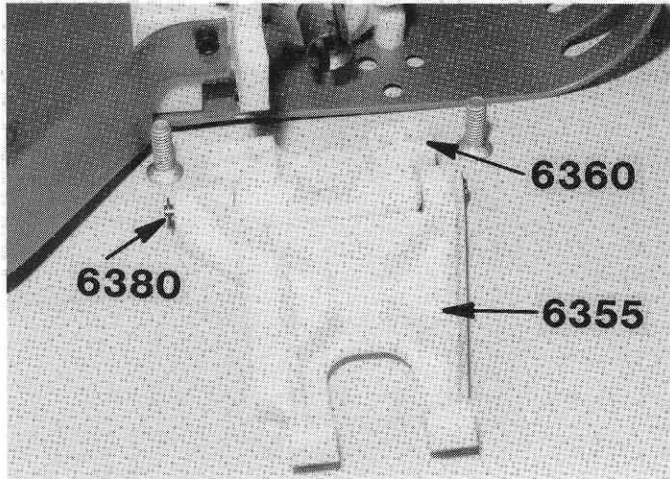

□ **Fig. 80** Install the L.H. mount to the chassis with two #6280 8-32 x 1/2" FHMS Phillips screws as shown, also from bag #6-8. Now install the R.H. arm. There are four holes in the mounts. Be sure you use the rear holes, which will keep the arms in the forward position.

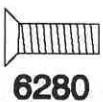
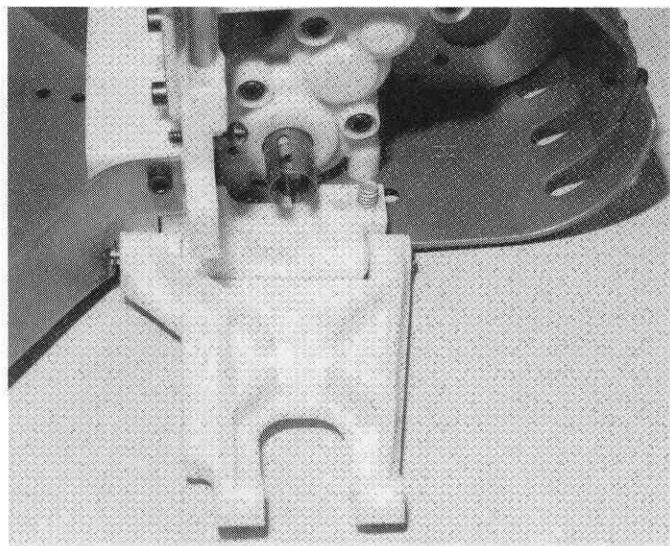

Fig. 80

□ **Fig. 81** Before proceeding with the assembly of the rear hub carrier, it's a good idea to check fit of the #6370 dogbone in the #6374 stub axle. These parts are in bag #6-8. If it does not slide and swivel freely, then check for burrs around the dogbone pins, burrs in the dogbone pin slots, and for heat-treating residue inside the stub axle. Also check that the #6272 dogbone spring fits freely in the small hole at the bottom of the dogbone socket (see Fig. 115). If either of these holes are clogged they can be cleaned by soaking the stub axle in hot or boiling water for a half hour. Dry and oil the stub axle after cleaning.

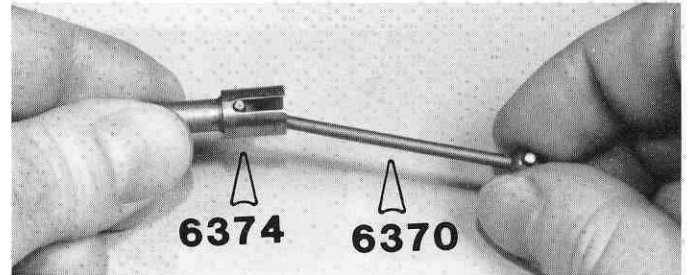

Fig. 81

□ **Fig. 82** Still working with bag #6-8, take the #6374 rear stub axle and slip the #6387 flat washer, as shown, onto the axle. Install the #6387 bushing into the #6366 R.H. rear hub carrier in the direction shown. (The L.H. hub carrier can be identified by the "L" molded into the back side of the carrier. The R.H. carrier has no markings.) Oil the bushing and slip the axle into the bushing. Now take the #6388 cone washer, the one that is not flat, and slip it on the shaft so that the part that touches the bearing or bushing is the center of the washer. Repeat the procedures for L.H. rear hub carrier.

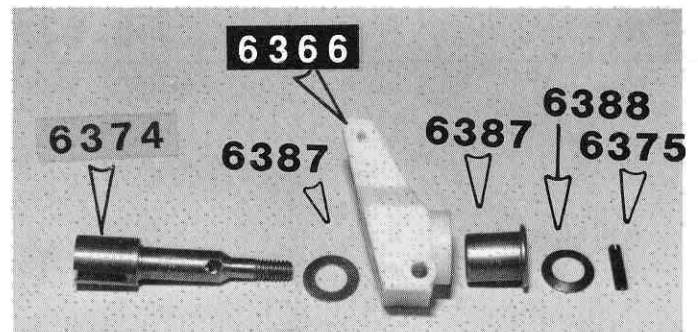
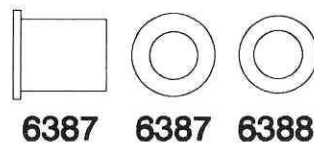

Fig. 82



□ **Fig. 83 & 83a** For this step you may need 3 hands, so get a friend to help you. Set the axle on a vise or a flat surface. Hold the roll pin or slotted pin with a needle nose pliers and align the pin with the hole in the axle. Lightly tap the pin in the axle so it's evenly spaced. These parts are in bag #6-8.

An alternate method of installing the pin is shown in Fig. 83a, using a pair of water pump pliers. Start the pin by holding with small pliers and pushing into the hole with a twisting motion. Finish with large pliers as shown. Angle the pliers slightly to allow the pin to come through the other side.

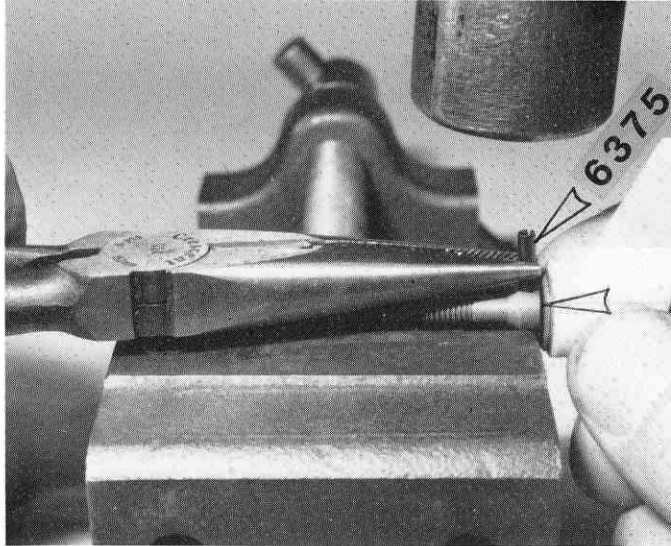

Fig. 83

6375

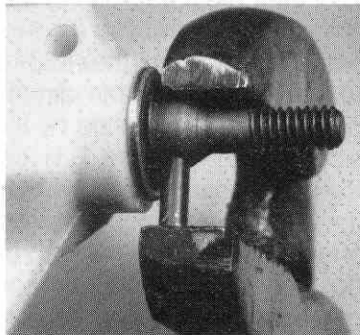

Fig. 83a

□ **Fig. 84** Install the LH hub carrier in the LH "A" arm with the #6381 outer hinge pin. Install two #6299 e-clips. Install a #6273 steel ball end (with the long threads) in the forward side of the hub carrier, as shown, with a #6295 4/40 plain nut. Install the R.H. hub carrier. The R.H. ball end should also face forward.

NOTE: The pin is intentionally a tight fit in the hub carrier; do not ream the hole. The pin will turn in the A-arm.

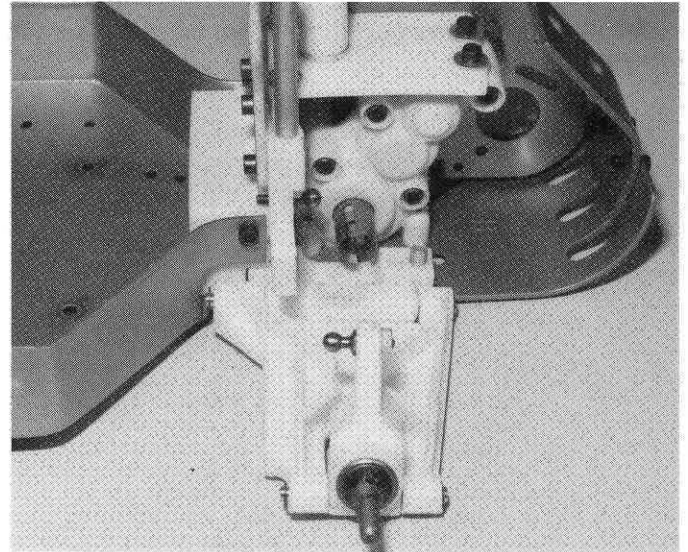
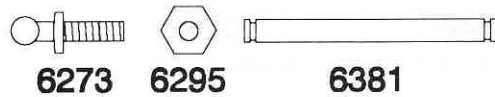

Fig. 84



□ **Fig. 85** Your L.H. rear end should look like this now.

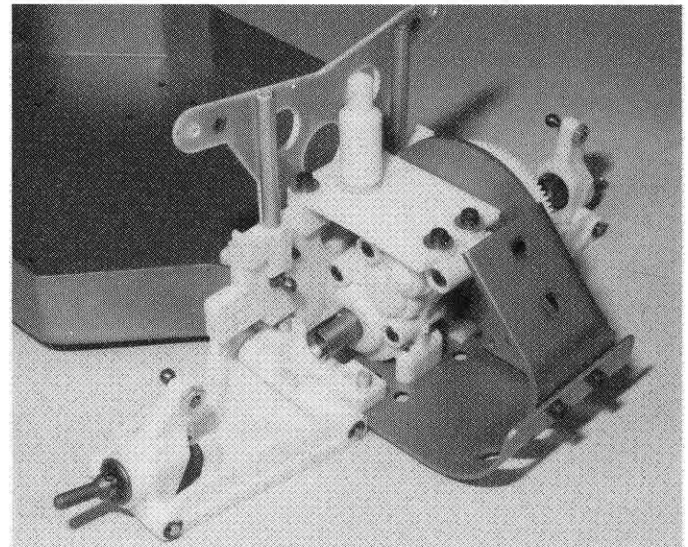

Fig. 85

□ **Fig. 86** Again from bag #6-8, take the two #6262 turn-buckle rods and screw two #6274 plastic rod ends on each to the dimension shown. Note that on this strut one ball faces forward and one faces to the rear.

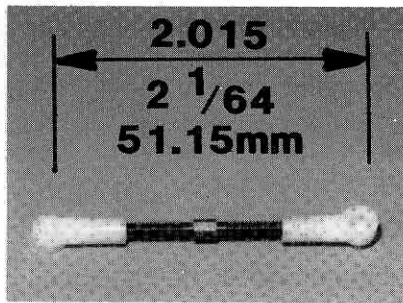

Fig. 86



□ **Fig. 87** Bag #6-8 also contains two #6372 springs and nylon washers as well as two #6370 dogbones. Install one nylon washer in each outdrive on Stealth tranny. (The outdrive is clearly pictured in Fig. 47.)

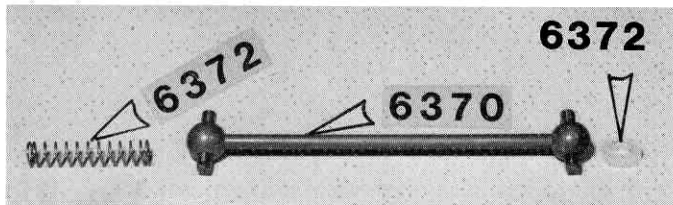

Fig. 87

□ **Fig. 88** Put the strut (A) onto the ball on the bulkhead. Put the spring inside the stub axle, and make sure the spring fits freely in the hole. If the spring binds you may be able to clear the hole with an Allen wrench; or you can reread step 111. Put the dogbone or half-shaft into the gear slot. Now, align the stub axle with the dogbone and slide it in. Put the strut (B) on the ball in the hub carrier. It should look like Fig. 116 now. Do the R.H. side.

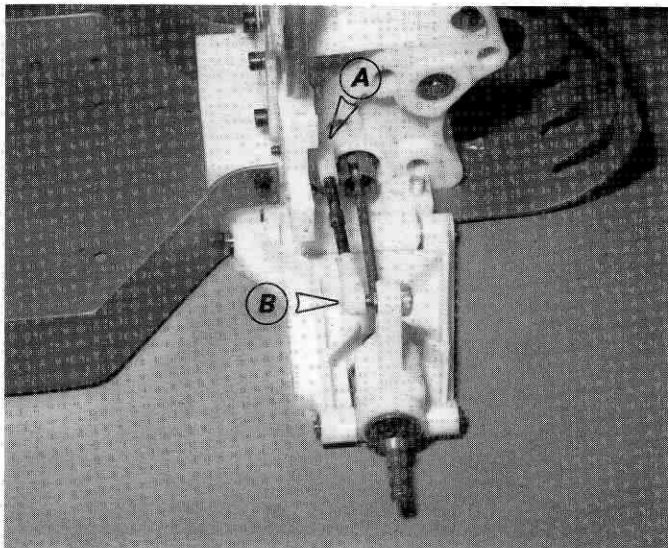

Fig. 88

SHOCK ASSEMBLY

□ **Figs. 89 & 89a** It's easier to build all four shocks at the same time. Open bag #6-9 and remove two #6458 shock shafts. Open bag #6-10 and remove two #6460 shock shafts. Install one #6299 E-clip on each shaft in the groove closest to threads.

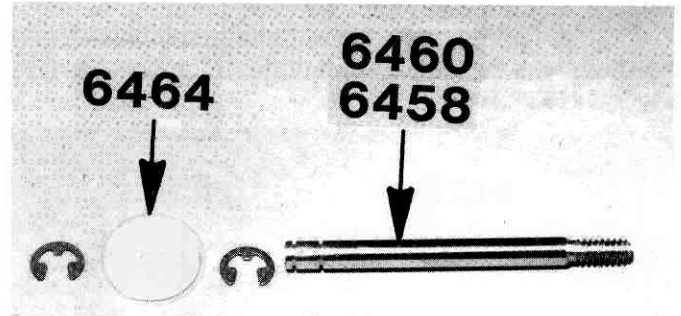

Fig. 89



Fig. 89a

□ **Fig. 90** Now slip the #6464 piston on each shaft, and then install the second #6299 E-clip. Make sure both E-clips are fully seated in the groove.

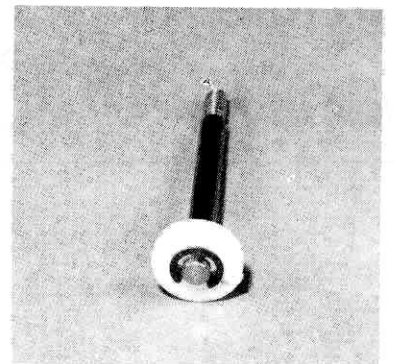

Fig. 90

Figs. 91 & 91a The #6429 assembly tool, from main plastic bag, makes it quite easy to build shocks. The internal shock parts will be slipped onto the assembly tool in the following order. First, the large split washer, then the small washer, red O-ring, spacer, red O-ring, and small washer. This is exactly as the order shown in the photo.

NOTE: Be sure to check the large split washer and small washers for burrs (raised edges). Carefully remove any found with an X-acto knife.

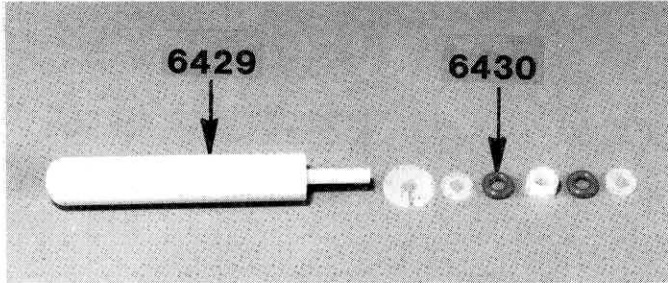
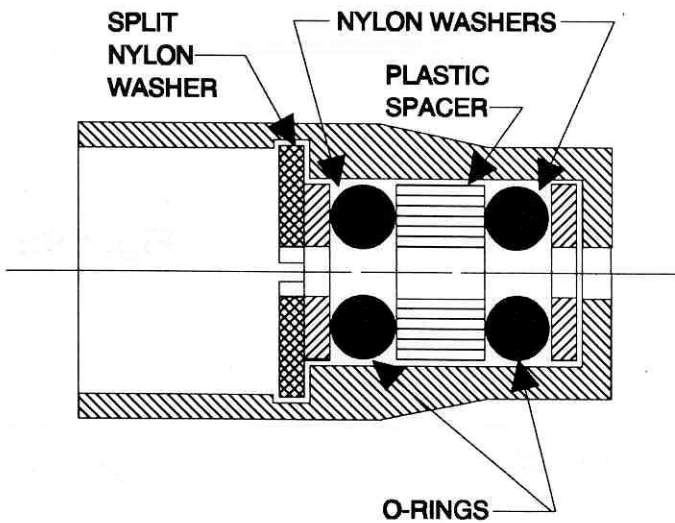

Fig. 91



(DRAWING NOT ACTUAL SIZE.)

Fig. 91a

Fig. 92 Your kit comes with a very high-quality shock oil, but if you want the best, Associated also has a special Silicone Shock Oil, which we highly recommend. If you're going to use the Silicone Oil, then do not build the shocks with the kit oil, because the two oils will not mix.



Fig. 92

Fig. 93 Apply a liberal amount of oil to the parts on the installation tool.

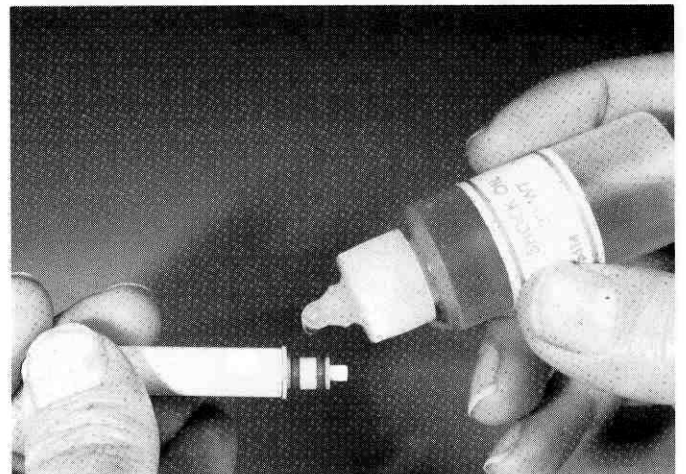

Fig. 93

□ **Fig. 94** Put a few drops of oil into the #6426 front and #6424 rear shock bodies to make assembly easier also. We don't want to cut the red O-rings on assembly.

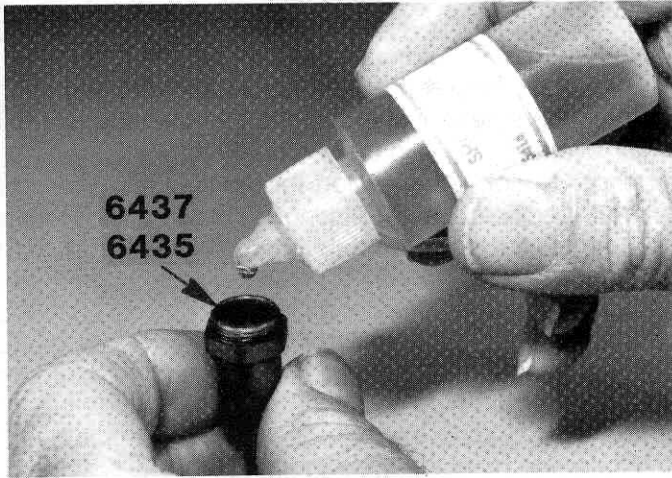

Fig. 94

□ **Fig. 98** After the split washer is fully seated, place a liberal amount of oil on the short shock shaft and slowly push it into the shock, and pull it all the way to the bottom.

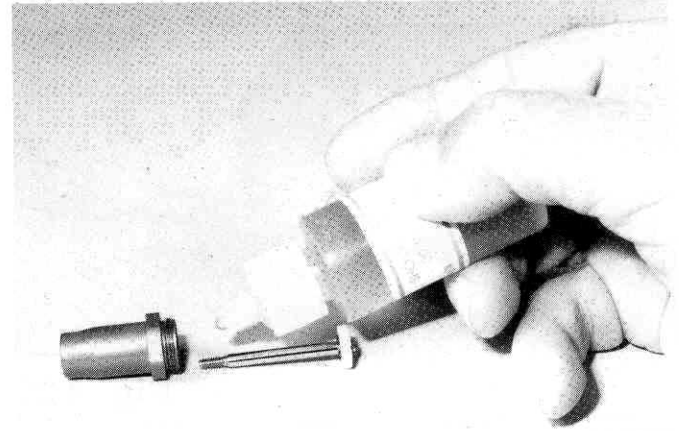

Fig. 98

□ **Figs. 95, 96, & 97** Now take the shock body and the installation tool and push the parts slowly into the shock body all the way down until it bottoms out. Then give it a hard push to seat the split washer. You should be able to hear the washer snap into place. Pull the installation tool out. Look into the shock body to check the installation. **IMPORTANT!** The split ring should look like fig. 97. If it looks like fig. 98, then the washer is not seated in the lock groove and the shock will come apart. **MAKE SURE THE WASHER IS FULLY SEATED IN THE GROOVE.** (Note: To remove the parts, take the installation tool, insert it up through the bottom of the shock, and push the split washer out.)

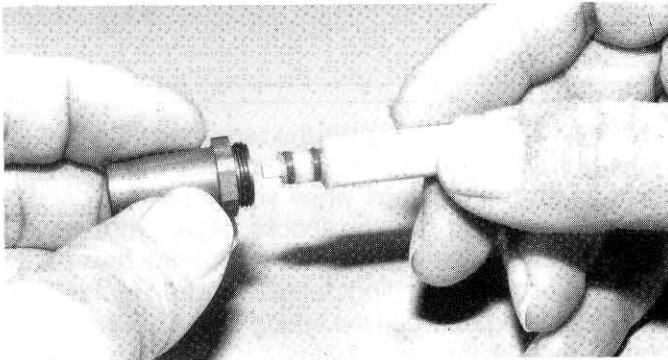

Fig. 95

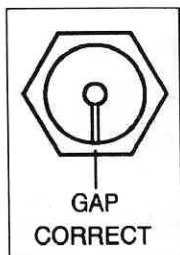

Fig. 96



Fig. 97

(THESE DRAWINGS ARE NOT ACTUAL SIZE.)

□ **Fig. 99** In bag 6-9 will be six #6466 nylon spacers. Slip three of these onto each of the long shafts, all the way up to the piston. These spacers are not used on the front shocks.

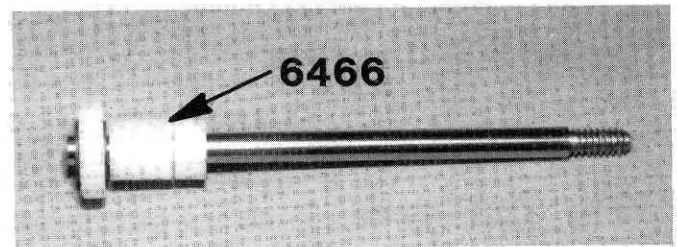

Fig. 99

□ **Fig. 100** Slip the #6469 black O-ring over the threads and seat it flush against the pocket at the bottom of the threads.

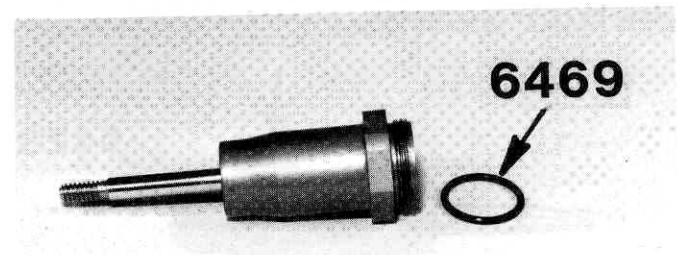

Fig. 100

Fig. 101 IMPORTANT: Thoroughly lubricate the threads in the #6428 plastic cap **BEFORE** installing. **IT MUST BE LUBRICATED FOR PROPER INSTALLATION.** We'll install it soon.

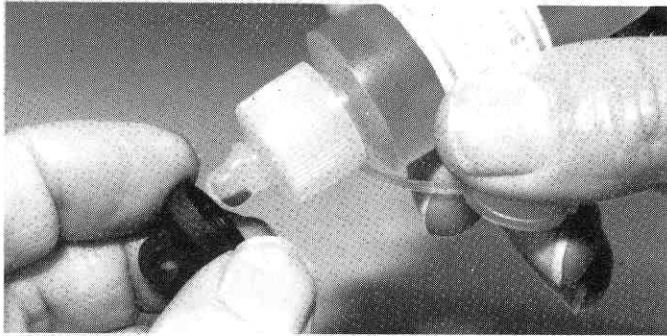

Fig. 101

Fig. 102 Fill the front shocks all the way to the top, but fill the rear shocks only to within 1/16" of the top.

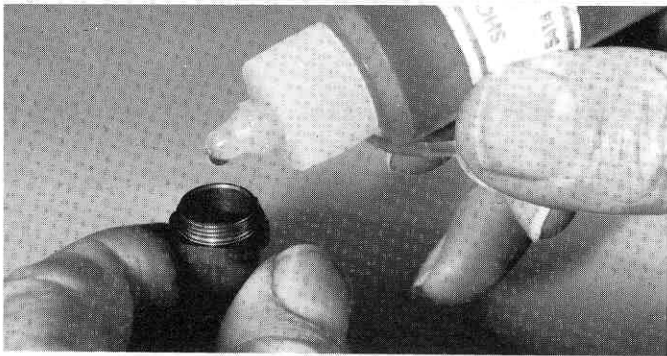

Fig. 102

Fig. 103 Push the shaft up so the piston is up to the top of the body, otherwise there will be too much internal pressure. **VERY CAREFULLY** screw the shock cap onto the body, making sure the cap goes on straight. **BE CAREFUL** not to crossthread the cap.

The cap needs to screw all the way down to the shock body. There should be no gap between the cap and bottom where the arrow is indicating. The O-ring will actually be doing the sealing so we must **BE CAREFUL** not to overtighten the cap and strip out the threads. As soon as the cap comes into contact with the body just turn it a **VERY SMALL** amount to seat it.

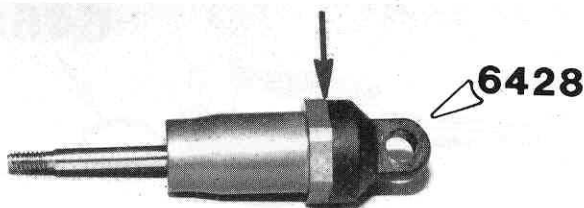

Fig. 103

Fig. 104 From bag #6-11 install two of the #6474 spring clamps on the rear shocks with two #6924 4/40 x 3/8" SHCScrews. The spring clamps have a thin flange on one side. Make sure this is facing the side the spring makes contact with. Install one with the screw head up and the other with the screw head down. There should be a 3/8" space between the collar and the body hex nut. Tighten the screws just enough to lock the collars. **DO NOT** over tighten. Slip on one of the #6480 long green springs. Check your catalog for springs with softer or harder specifications. Our testing has shown these springs to be the best all around spring for almost all off road racing. Now take the #6471 plastic rod end and press it onto the #6471 metal ball end. The easiest way to do this is to set the metal ball end, flat side down, on a table. Place the plastic rod end over the ball and push it in place with a 1/4" nut driver. Now you will want to thread the plastic onto the shock shaft. You will need to keep the shock shaft from rotating by holding it with needlenose pliers. Grab the shaft close to the threads so that you do not scratch the part that rides in the o-rings. **WARNING!** make sure that you grab the shaft with the smooth part of the pliers jaw. Now compress the spring enough so that you can slip the #6474 plastic split spring collar over the plastic rod end and shaft. Press the split spring collar down over the rod end until it seats and then let the spring seat over the collar.

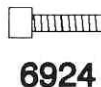
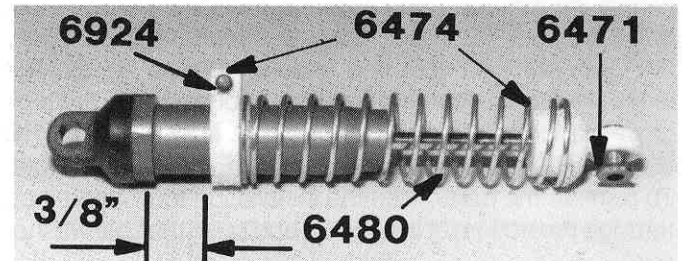

Fig. 104

Fig. 105 Working with the same bag #6-11 we will repeat the above steps for the front shocks. Use the #6494 short green front springs when you get to the point of installing the springs on the shocks. Again your catalog will list additional springs which will allow the driver to try different suspension settings for different track conditions. Set the spacing between the spring clamp collar and the body hex nut at the same 3/8"

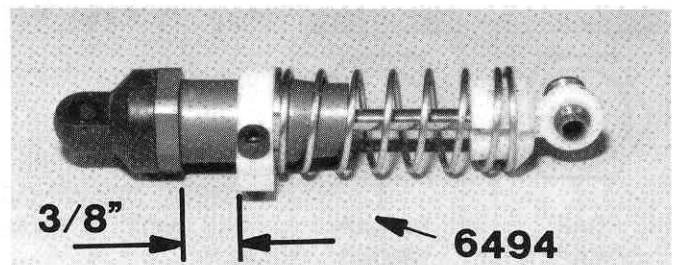

Fig. 105

Fig. 106 Now we'll install the front shocks on the car. The arrow in the photo is pointing to the upper mount. Taking parts from bag 6-10, slip on a #6936 #4 aluminum washer and then screw down and tighten one of the #6295 4/40 plain nuts. The arrow is pointing to the #6473 flanged nylon shock bushing. Slip this bushing on next, with the flanged end on first.

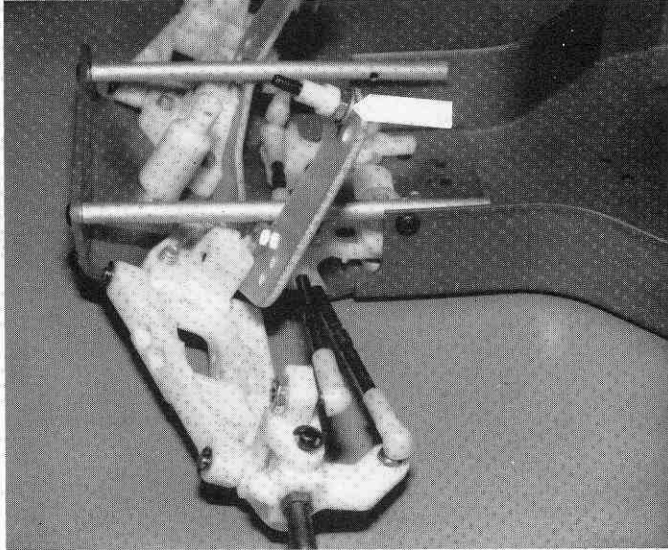

Fig. 106

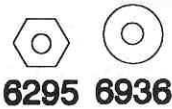

Fig. 107 Slip the shock on the upper mount and install a #6295 4/40 locking nut. DO NOT tighten down too tight on this nut or you'll bind up the shock. Squeeze the bottom end of the shock up and then slip the end down into the lower "A" arm slot, with the flat side of the ball to the rear.

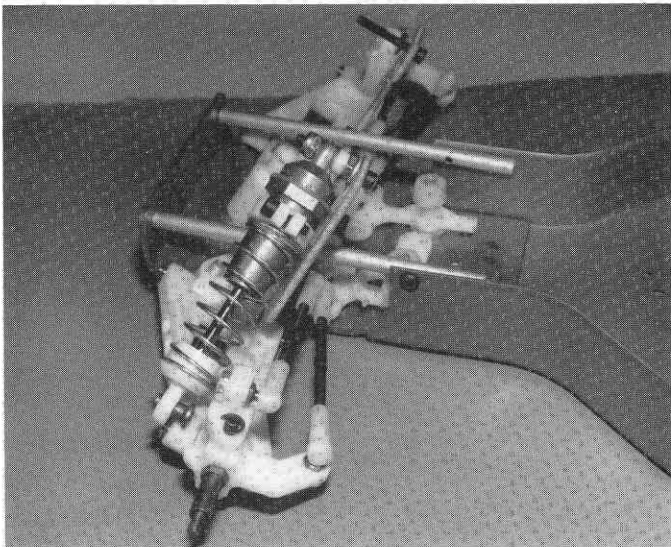

Fig. 107



Fig. 108 The flat side of the ball should be towards the rear as the upper arrow shows. Now, back in Bag #6-1 you have two #6930 4/40 x 3/4" long special shock screws that only have 1/4" of threads. Use these screws to mount the lower shock balls to the "A" arm, as shown. make sure you use outer mounting holes.

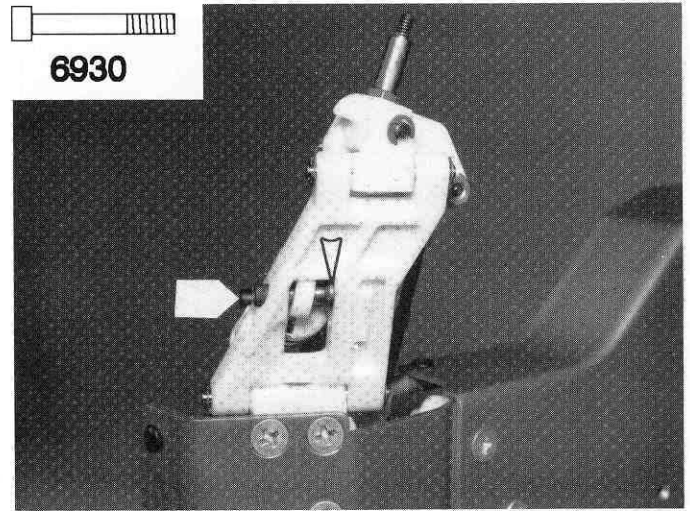

Fig. 108

Fig. 109
Install the R.H. shock.

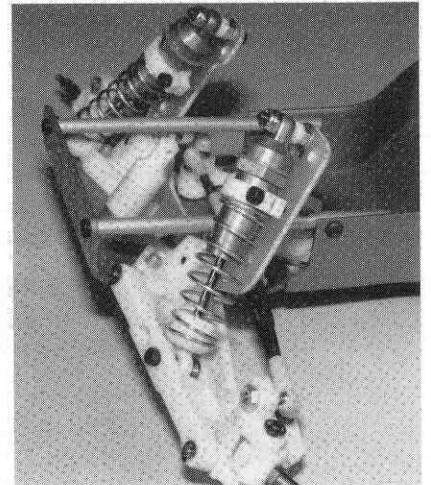

Fig. 109

Fig. 110 In Bag #6-4 are the 2 #6320 nose brace tubes and four #6288 4/40 x 1/4" BHSS Allen button head screws, as shown.

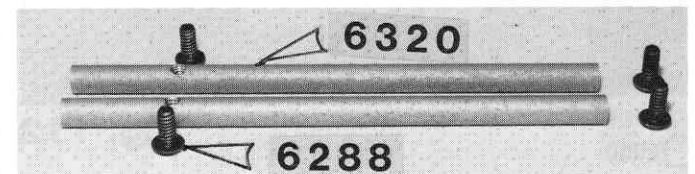

Fig. 110

□ **Fig. 111** These tubes tie in the nose piece very solidly to the chassis. Start by installing the rear screw through the side of the chassis, but do not tighten yet. Install the forward screw through the front of the nose piece into the end of the rod and tighten down. Now tighten the rear screw. Install the 2nd brace.

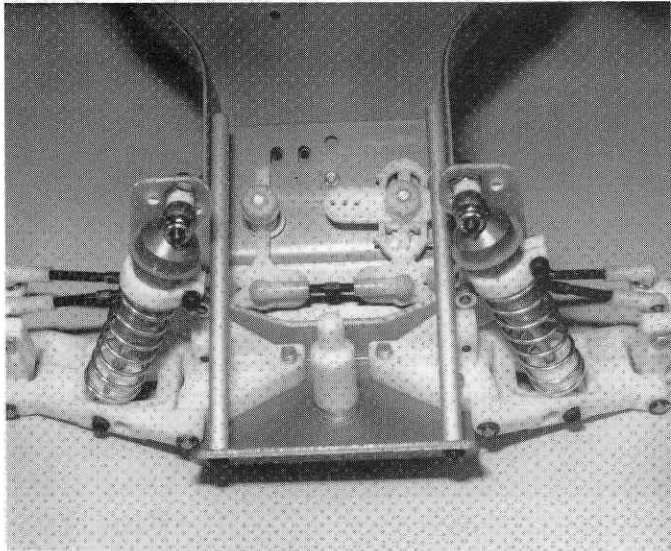

Fig. 111

□ **Fig. 112** Also in Bag #6-4 is the #6378 rear shock strut. Assemble this to the rear bulkhead with the four #6932 4/40 x 5/16" SHCS Allen screws, as shown.

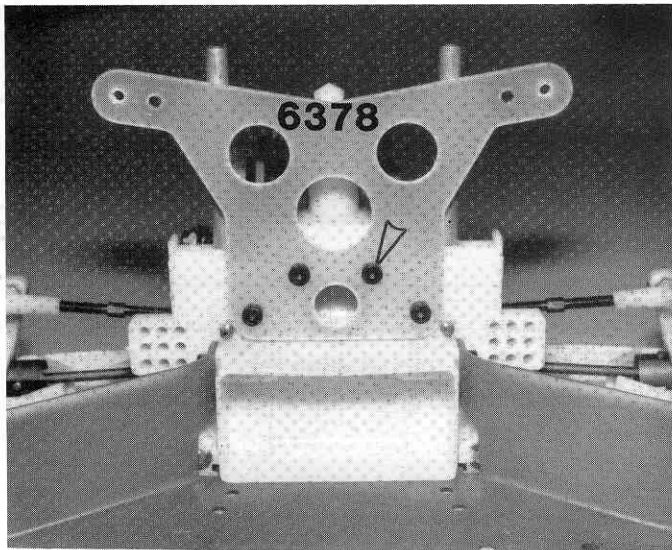

Fig. 112

□  **6932**

□ **Fig. 113 & 114** It's time to install the rear shocks. From Bag #6-9, install one of the #6927 4/40 x 3/4" SHCScrews through the inner hole of the shock strut. Install it from the rear as shown. Slip on a #4 aluminum flat washer and then thread on a #6295 4/40 plain nut. Slide a #6473 shock bushing onto the bolt with the flange end first. Now slip the shock end over the screw and onto the bushing. Now install the R.H. shock.

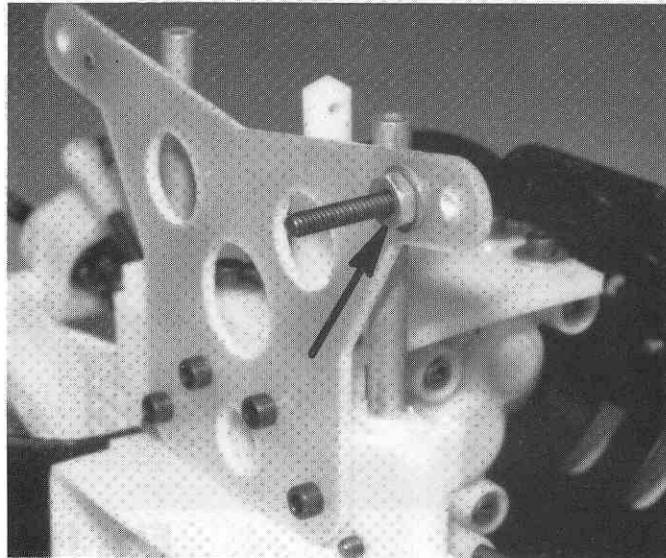

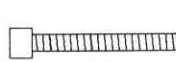

Fig. 113

□   
6936 6295 6927

□ **Fig. 114** Install a #6936 #4 washer and a #6295 4/40 nylock locking nut next. Do not overtighten the nut, it is only necessary for the nut to take up the end play. Now do the other shock.

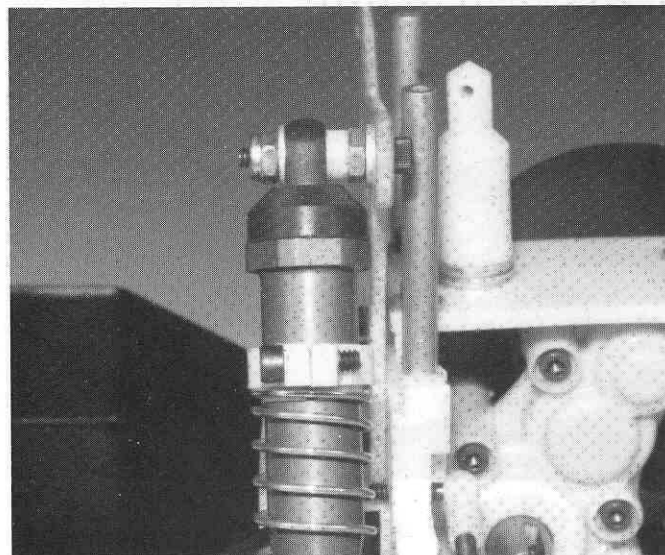

Fig. 114

□ **Fig. 115** For the shock bottom installation we want the flat part of the metal ball end to be against the A- arm, as shown. In the A-arm, there are four holes. Install it in the outside hole, as shown. Slip a #6936 #4 flat washer on the #6927 4/40 x 3/4" SHCScrew, and install the screw through ball and into the arm.

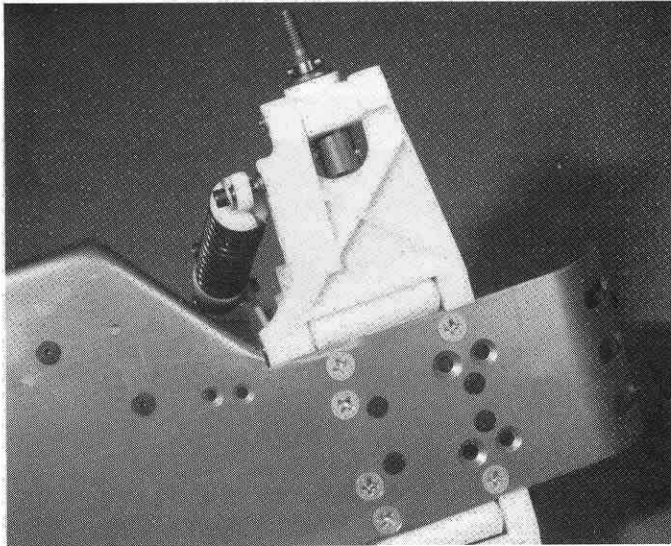
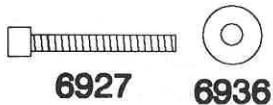

Fig. 115



MOTOR MOUNTING

□ **Fig. 116 & 116a** Time to put the horsepower in the car. Using ROSIN core solder, solder the motor lead wires and filter capacitors to the #6500 stock motor, according to the instructions in the motor bag. From bag #6-15, take the #8258 21 tooth, 48 pitch pinion and install it on the motor shaft as shown. Start with the end of the pinion even with the end of the shaft (Fig. 117a). Remove the plastic gear cover we installed earlier.



Fig. 116

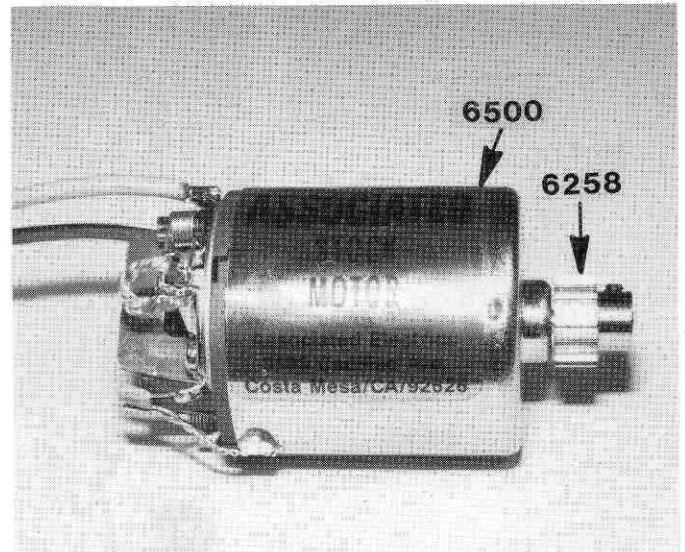

Fig. 116a

□ **Fig. 117** In the motor bag are two #6515 gold, metric, motor mounting screws. These screws have finer threads, 3mm, and are used **ONLY** to mount the motor. Slip the motor in the motor mount and start the bottom screw in first. Do not tighten all the way down yet. On the top screw, put a #6936 aluminum #4 washer on the screw and screw it in, but not tight. Now we'll set the gear mesh. By moving the upper screw, forward or back, we'll be moving the motor closer to, or away from the plastic spur gear. What we want to do is to get the metal pinion gear as close to the plastic spur gear as we can without binding up the gears. The easy way to check this is to put your finger on the plastic gear and see if you can rock it in the teeth of the metal gear. The two gears should be as close as possible, while still being able to very slightly rock the plastic gear.

When you have this correct spacing, tighten down on the two motor screws and re-check the gear spacing. An incorrect gear mesh can result in a huge power loss, so do it correctly. Now recheck the pinion location and make sure it is centered on the spur gear. If it is off, loosen the pinion set screw, realign, and tighten.

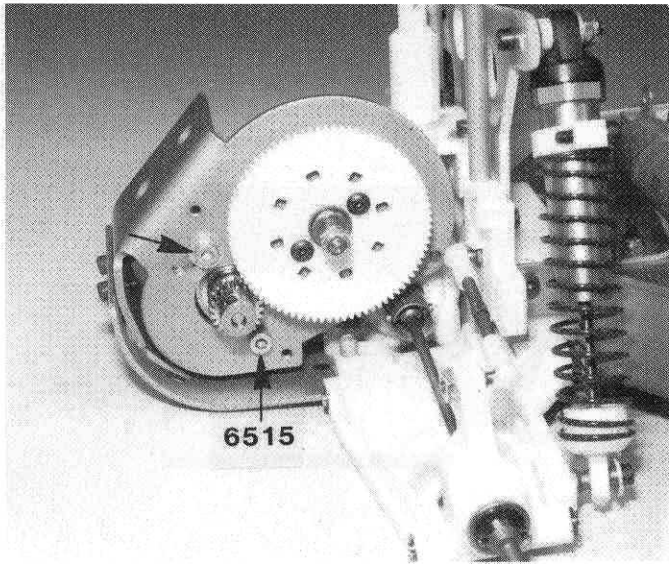

Fig. 117

#43 (2.3mm) holes in each mount on the side away from the chassis mounting hole, which will be on the bottom of the mount. You'll notice that the chassis has 2 sets of servo mounting holes. A short set and a long set. With 2 different sets and by rotating the servo mounts 90 deg, you will be able to mount most servos. Attach the servo to the mounts with four #6921 4/40 x 5/16" BHSS Allen screws and #4 flat washers, as shown.

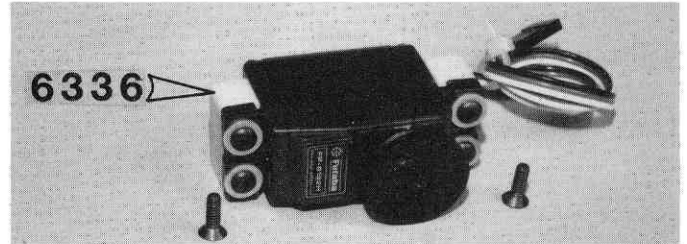
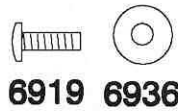

Fig. 118



RADIO INSTALLATION

We're ready to install the radio. If you have not purchased a radio yet, try to stay with a name brand like Futaba or Airtronics. However, many other radios, including stick models, can be used in the car. The higher torque medium sized servos (like the Futaba S128, S148, S131's, 9401, 9301, 9201 or 9101; or Airtronics 94102, 94732, or 94737) are preferred for steering. Small servos like the Futaba's S132's are best for the throttle; but both sizes, small and medium, can be made to work.

The photos that follow show the installation of a Futaba S132 or S28 servos. Special instructions and photos for medium are also included. In these instructions, servo sizes (the width of the case between the mounting ears but not including the ears) are grouped as follows:

SMALL (S132)	1.5 in. (38mm)
MEDIUM (S131)	1.6 in. (41mm)

Special Instructions: Small steering servo

□ **Fig. 118** In Bag #6-6, take out 2 of the #6336 plastic servo mounts. You'll have to drill the mounts for your particular servos. If you have S32 servos, line up your servo with the mounts, so that there will be about 1/16" (1.6mm) clearance between the servo and the chassis plate and mark the hole locations on the mounts. Drill two

□ **Fig. 119 & 120** Install the servo to chassis with the two #6292 4/40 x 3/8 FHSS Allen screws shown in drawing below. You'll have to install two #4 flat washers between the rear mount and chassis for proper alignment. Fig. 121a shows the proper holes to use with small servos.

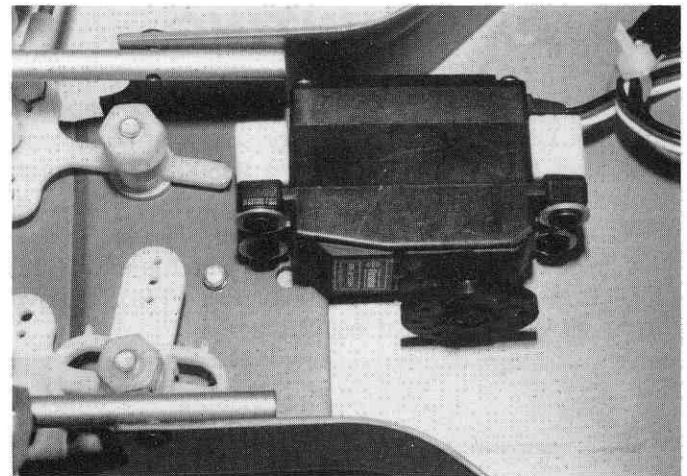

Fig. 119

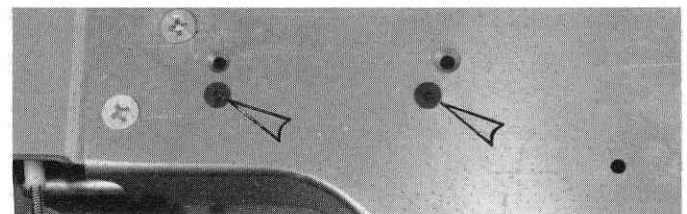

Fig. 120



□ **Fig. 121** From bag #6-2, take out the #6256 "Z" bend piano wire linkage and set collars. Locate the servo horn that comes with your radio that looks like a "+" or "-" shape but with a mounting hole in the center. You will need to cut off one or three of the arms on the servo horn depending upon which one you have. Make sure that the one arm of the horn that you are leaving is the longer one. (The round servo horn is not recommended.)

You will now want to install this horn on the servo. Turn the servo horn to the left and right stops making sure that you have equal travel on both sides. It will not be exact, but it will be close enough for now. We'll center it exactly with the radio later.

Now slip one of the "Z" bend rods into the upper hole of the servo horn arm. Install the other "Z" bend rod in the servo saver arm as shown. The "Z" bend will be easier to install in the servo saver arm if you take your X-acto knife and rotate it in the hole to bevel it slightly. The arrow in the photo is pointing to the slight bend that we want to put in the wire so the collars will clear the servo. Put a slight bend in the rod and then install it into the servo saver arm, as shown. Center the servo saver and vertically center the servo horn then install and tighten both locking collars. **NOTE:** It may be necessary to cut the "Z" bend rods to prevent any binding.

Futaba

Futaba Futaba Kimbrough

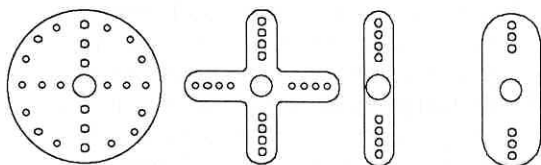

TYPES OF SERVO HORNS

(THESE DRAWINGS ARE NOT ACTUAL SIZE.)

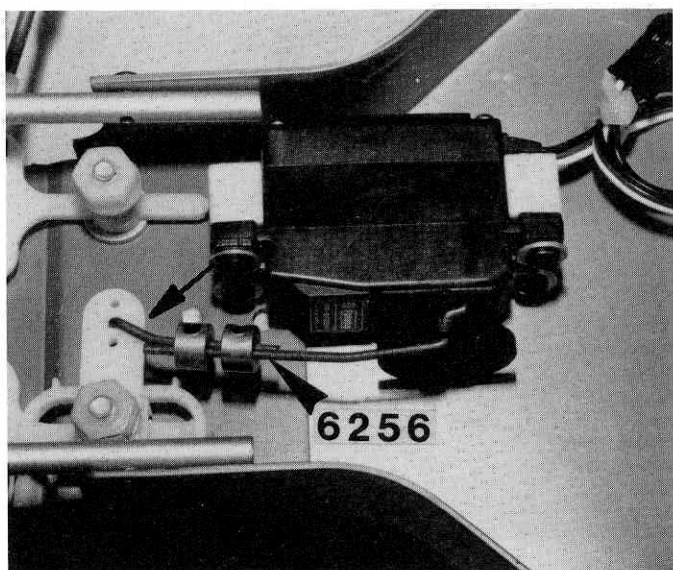

Fig. 121

Special Instructions: Medium steering servo

□ **Fig. 122** Page 35 lists the medium-sized servos, along with Novak NES1A. Follow the same procedure for the small servo but use the wider-spaced mounting holes in the chassis. Again, the round servo horns are no longer used for the steering servo.

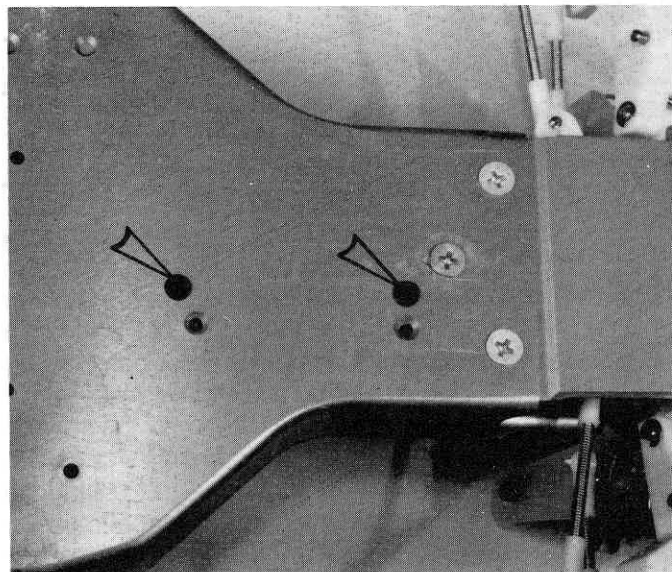
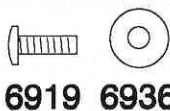

Fig. 122



6919 6936

□ **Fig. 123** Linkage is the same as for small servo but may require slightly more bend.

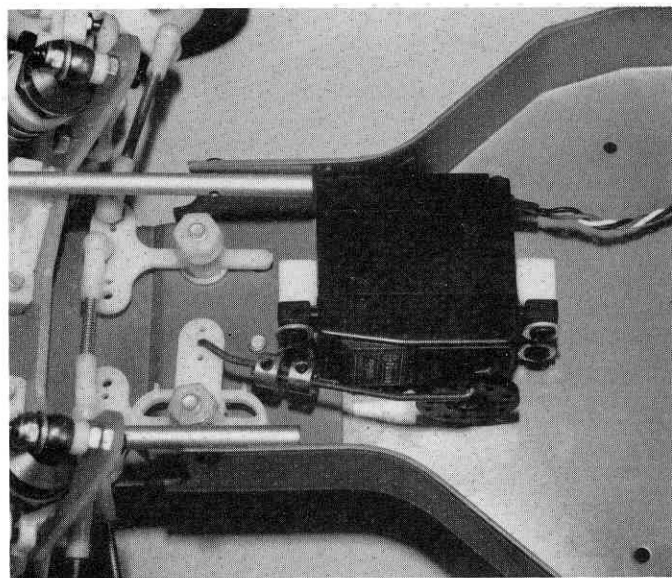

Fig. 123



6292

THROTTLE SERVO

Because of the great variety of servo sizes and manufacturers now available, the following installation instructions are meant as a guideline. New pre-bent resistor brackets are designed to fit as many servos as possible. **NOTE:** Airtronics small servos are not recommended for use as a throttle servo. Later are written installation instructions for both Futaba and Airtronics medium sized servos, and instructions for installing small Futaba servo sizes.

□ **Fig. 124 & 124a** Fig. 129a shows the three sets of mounting holes that are used for mounting the resistor and various manufacturers servos. Each set of holes are labeled to simplify the instructions. For Futaba small servos (servo shown is a Futaba S32) from bag #6-5 take two #6292 4/40 x 3/8" FHSS and two servo mounting blocks and mount the blocks to the chassis using the mounting holes marked "A". The servo block mounting holes should be to the back putting more of the block in front of the mounting screw. Place the servo between the mounting blocks. It should fit between with just a little pressure. Push the servo down until the top of the servo is level with the top of the mounting blocks. This should give you enough clearance to prevent the wiper (still to be installed) from touching the chassis. The servo must be installed with the output shaft on the right or passenger side of the car (left side in photos). Mark the servo blocks for the center point of each mounting hole. Remove the servo mounting blocks and drill each mounting location with a #43 drill bit (a 3/32" drill bit will work but keep it very steady when you drill). Now mount the blocks to the servo using four #6919 4/40 x 5/16" BHSS and four #6936 #4 aluminum washers. Make sure that the chassis to servo block mounting hole is to the back of the servo.

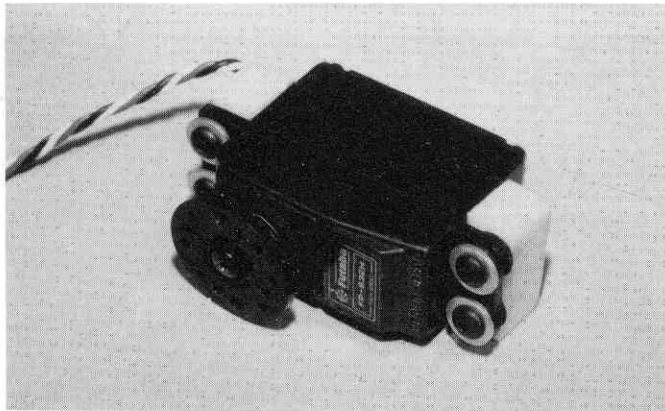
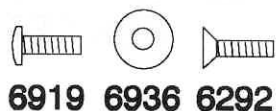
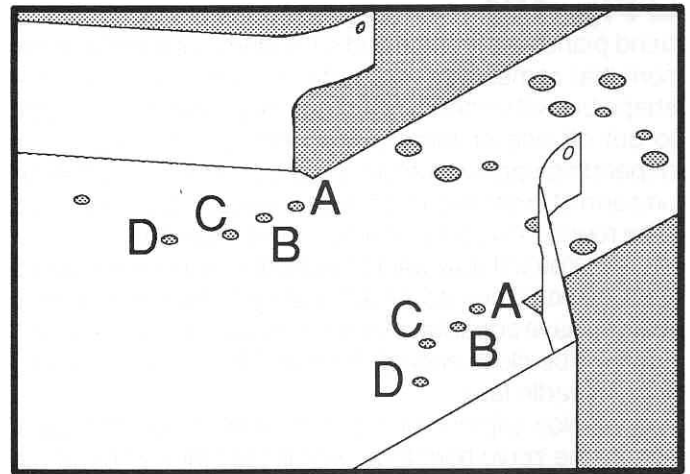

Fig. 124



6919 6936 6292



(DRAWING NOT ACTUAL SIZE.)

Fig. 124a

□ **Fig. 125** If your servo comes with a small round servo horn this will be the best choice for this installation. If not, you will have to modify, as necessary, the servo horn that comes with your radio so the servo horn can rotate freely thru its arc. Install the round servo horn on your servo. Install the servo and blocks to the chassis on the "A" mounting holes, as shown, using the same two #6292 4/40 x 3/8" FHSS fasteners we used earlier. It is important that the servo mount high enough to allow the servo wheel to clear the chassis by about 1/8" (3.1mm). Add washers under the mounts if necessary to give the required clearance.

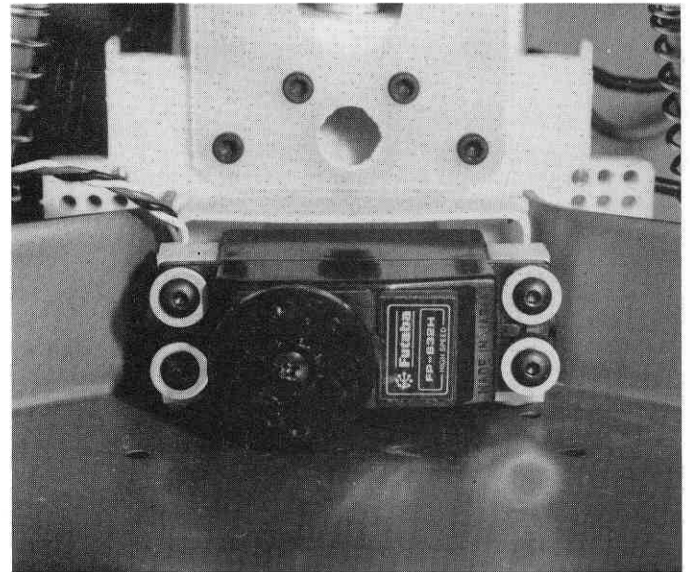

Fig. 125



6292

□ **Fig. 126 & 126a** From Bag #6-13, install the two #6713 bent resistor mounting brackets to the "C" holes of the chassis with two #6922 4/40 x 1/2" FHSS and two #6295 locknuts as shown. Make sure that the angles in the brackets are facing towards the back of the car. The lower bend will be towards the front of the car. The upper portion of the brackets should also be close to vertical, if not, bend to correct.

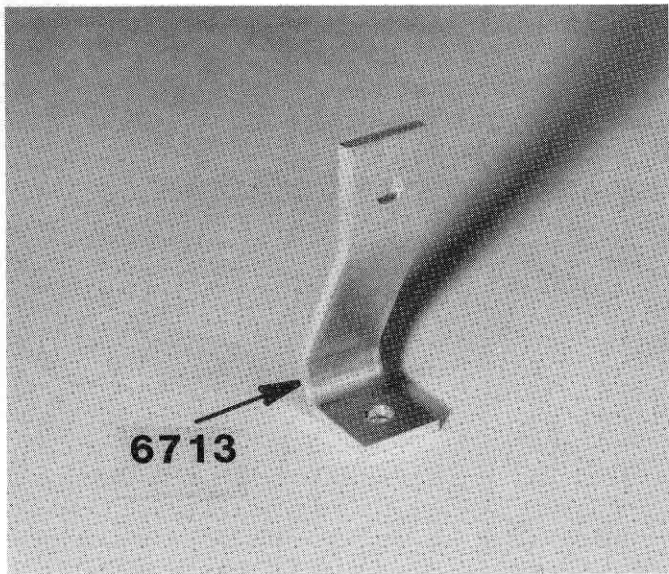

Fig. 126



6922 6295

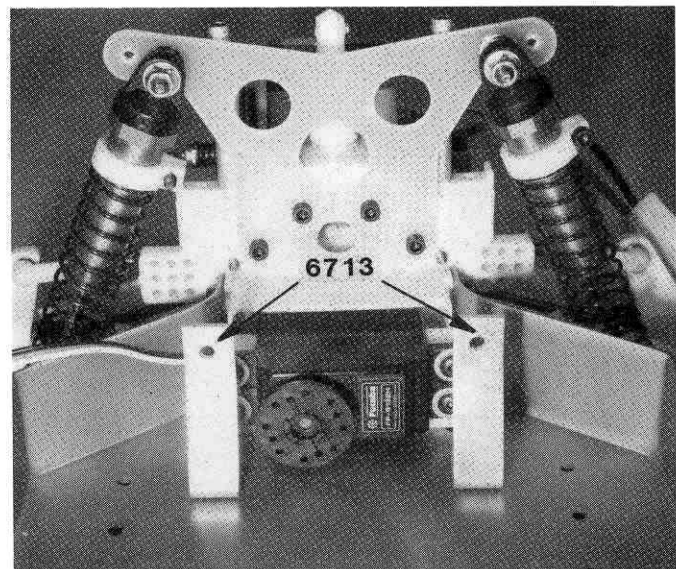

Fig. 126a

□ **Fig. 127** Slip the flat aluminum mounting bar through the #6711 resistor, both from bag #6-13. Install the resistor mounting bar on the back side of the brackets (closer to the rear bulkhead). The drivers side (right side in photo) of resistor mount will be secured using a #6924 4/40 x 3/8" SHCS and a #6295 4/40 locknut. On the passenger side (left side of photo) install the #6714 plastic bypass mount with the #6925 4/40 x 1/2" SHCS and #6295 4/40 locknut. There are two plastic bypass mounts. Use the mount with the round corners (may be yellow colored) for this servo setup.

Page 44 shows a detailed drawing and a photo on the wiring installation. That page helps clarify each step or part as necessary, so turn to it often for the next steps.

WARNING: Use only Rosin core solder for all of the following electrical connections.

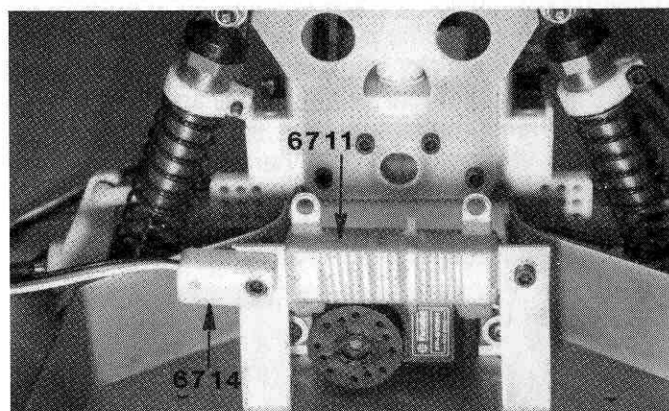

Fig. 127



6924 6295 6925

□ **Fig. 128** Center the servo output arm (or horn), as before, then turn it about 30 degrees to the right, or drivers side, of the photo. Locate the #6712 wiper arm (in bag #6-13) so that it is in the exact location shown and note the closest holes in the servo arm/horn to this location. Mount the wiper arm to these holes using the servo arm mounting screw (for the center) and the small #2 self tapping screw and #2 flat washer on the bottom. These are in bag #6-13. Solder the red wire from the #6745 motor output plug to the wiper arm in the location shown in the photo. NOTE: If your servo arm or horn has a raised center then use the extra #2 flat washer between the wiper arm and servo arm/horn to stand the wiper off from the edge of the servo arm. Install the servo arm/horn and wiper arm onto the servo output shaft and secure with the servo arm/horn screw.

This next item is **VERY IMPORTANT**. The wiper arm brass button must push quite firmly against the resistor in order to make good contact. If it does not have enough pressure the motor will not operate to its fullest horsepower and you will burn out the resistor. An easy way to check this is to take the fingernail of your smallest finger and lift the button a very small amount off the resistor. If it lifts off quite easily, its too soft. It should pull quite hard on your fingernail, BEFORE it lifts off - then it's correct. You can adjust the resistor mounting brackets for this or you can bend the wiper arm if necessary to achieve the correct tension.

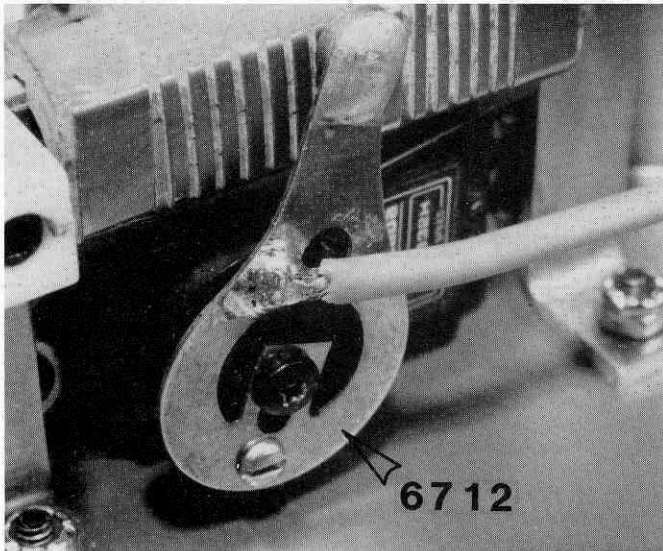

Fig. 128

Special Instructions: Medium throttle servo

□ **Fig. 129 & 130** See the beginning of radio installation section for a description of servo sizes (page 36). Do the following steps to mount a medium sized Futaba or Airtronics throttle servo. From bag #6-5 take two #6292 4/40 x 3/8" FHSScrews, and two plastic servo mounting blocks. Install the servo mounting blocks to the chassis using the "B" chassis mounting holes as in Fig. 130. The servo mounting blocks must be mounted with the chassis mounting hole to the back and the large section of the block to the front.

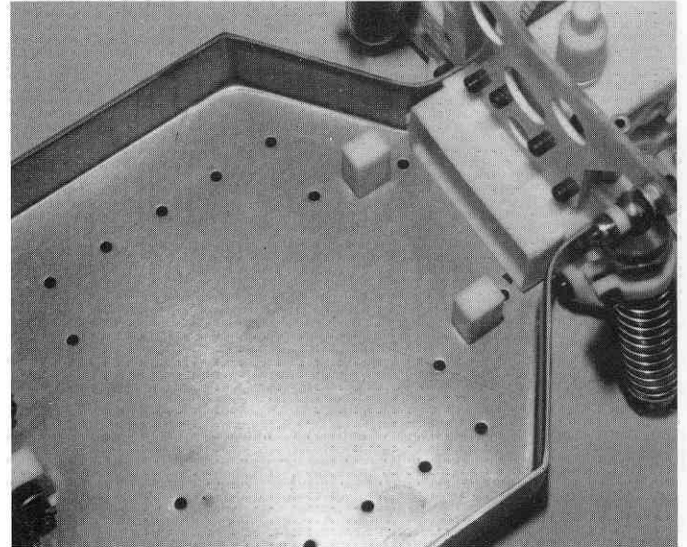

Fig. 129

□ **Fig. 130** Use the "B" holes, as marked in photo, to mount medium size servo.

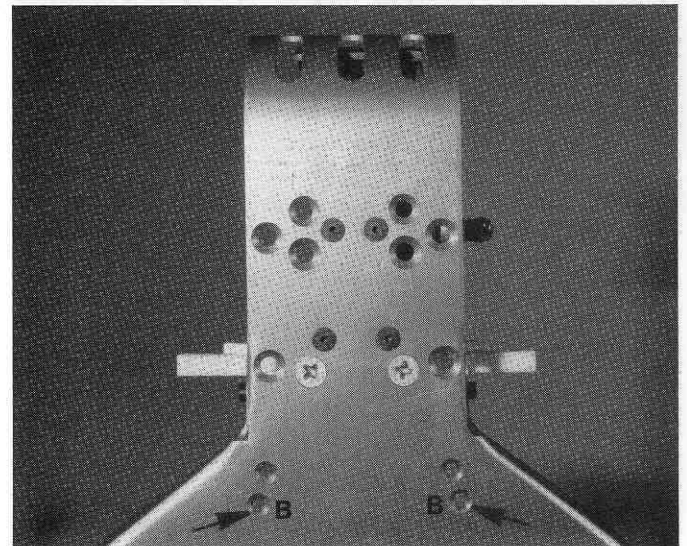

Fig. 130

□ **Fig. 131** Drop in the servo and space it off the chassis using the #6711 resistor flat mounting bar (from bag #6-13). Be careful not to damage the servo wires, they can be snug in the bulkhead. Mark the servo mounts with a pencil or fine point marking pen. Remove the servo mounts from the chassis then drill and install the mounts as per instructions in fig. 124. **NOTE:** Make sure the servo is turned so that the output shaft is on the correct side (left side of photo).

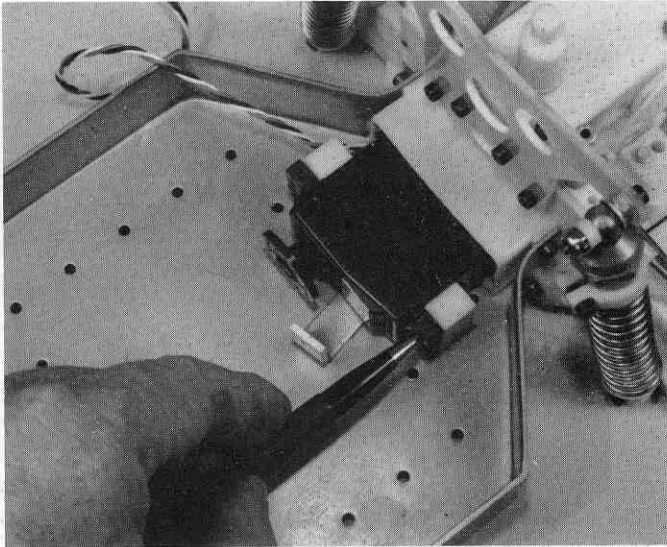

Fig. 131

□ **Fig. 132** Reinstall the servo to the chassis, using the same #6292 4/40 x 3/8" fasteners used earlier, on the "B" mounting holes as shown in fig. 130. It is important that the servo horn and wiper clear the chassis by about 1/8" (3.1mm). This will prevent any possibility of the wiper hitting the chassis and grounding the battery to the chassis. Also some servos (the Futaba S28/S128 for instance) are very deep and may bottom out against the back of the bulkhead, making alignment with chassis holes difficult. In this case you should put washers between the mounts and the servo to space the servo away from the bulkhead.

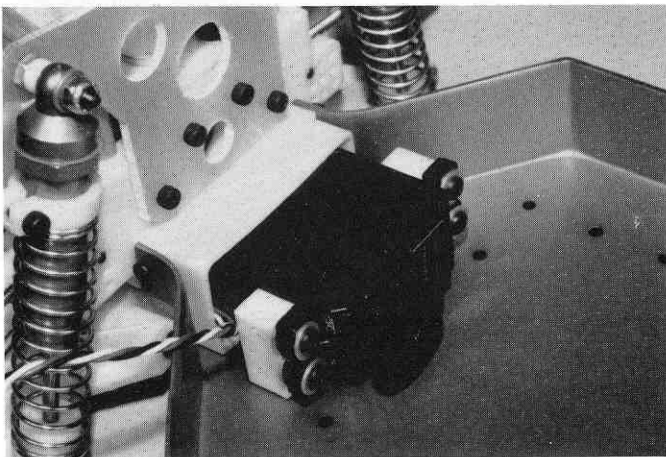

Fig. 132

□ **Fig. 133** Follow the first part of instructions for step 128 to determine the mounting position for the wiper arm and soldering the wires. It may be easier to remove the servo from the chassis to mount and solder the wiper arm and then reinstall the servo to the chassis.

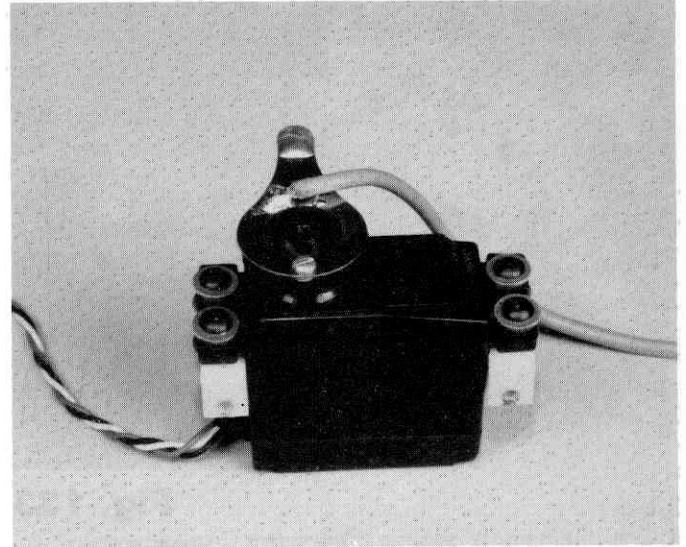

Fig. 133

□ **Fig. 134** The setup for Futaba and Airtronics servos varies somewhat. From bag #6-13 take two #6922 4/40 x 1/2" FHSScrews and two #6295 4/40 locknuts and mount the two #6713 bent resistor mounting brackets. Make sure that the angles in the brackets are facing towards the back of the car. The lower bend will be towards the front of the car. Be sure to use the "C" holes of the chassis as shown in fig. 124a. Make sure that the upper portion of the brackets are close to vertical, if not, bend as necessary to correct the problem. **FUTABA SERVO:** Slide the flat aluminum mounting bar through the #6711 resistor (all from bag #6-13) and install the resistor and bar in front of the brackets, as shown in photo. The drivers side of the resistor (right side in photo) will mount using one #6924 4/40 x 3/8" SHCScrew and one #6295 4/40 locknut. On the passenger side of resistor (left side of photo) Install the #6711 thick plastic bypass mount (white with square edges) using one #6927 4/40 x 3/4" SHCScrew and one #6295 4/40 locknut. When assembled, check for proper wiper pressure as in step 128. If the wiper pressure is wrong, it may be necessary to adjust the resistor mounting brackets to correct the problem. **AIRTRONICS SERVO:** Slide the flat aluminum mounting bar through the #6711 resistor. Now mount the resistor and bar on the back side of the brackets. The drivers side of the resistor (right side of photo) will mount using one #6924 4/40 x 3/8" SHCScrew and one #6295 4/40 locknut. Install the passenger side of the resistor (left side of photo) using the thin plastic bypass mount (yellow colored with round corners), one #6925 4/40 x 1/2" SHCScrew and one

#6295 4/40 locknut. The rest of the the installation will be the same as for a Futaba servo as explained earlier in this step.

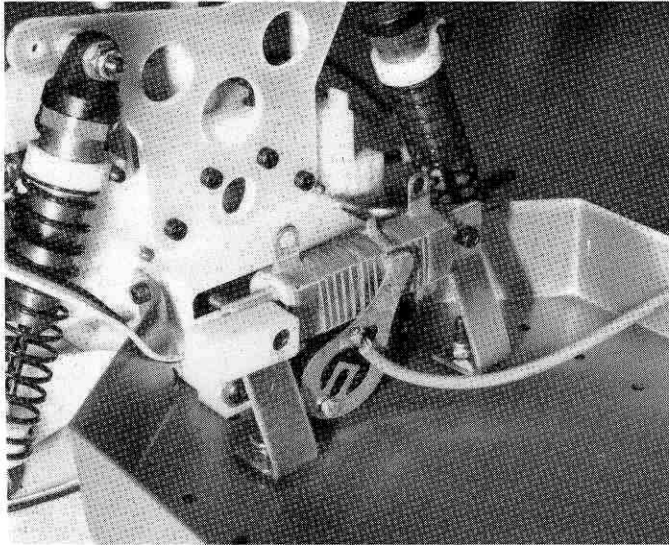
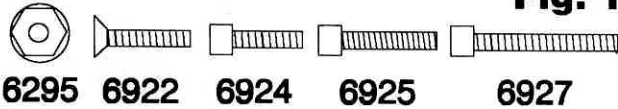

Fig. 133



6295 6922 6924 6925 6927

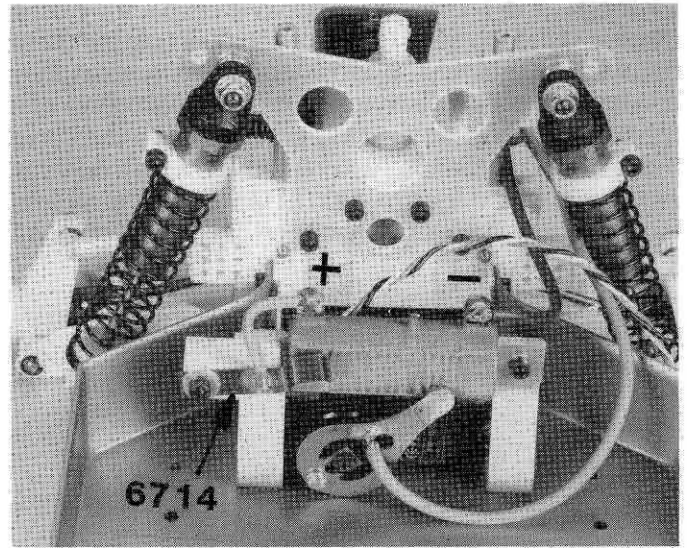
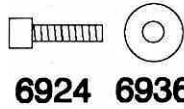

Fig. 135



6924 6936

FINAL RADIO ADJUSTMENT AND WIRING

Fig. 135 From bag #6-13 take the #6714 brass bypass tab and install it to the #6714 plastic bypass mount using a #6924 4/40 x 3/8" SHCScrew and a #6936 aluminum flat washer. Align the indented portion of the bypass tab right in the center of the wide bank of the resistor. Solder a small piece of red 16 guage wire, from bag #6-13, one end to the positive terminal of the #6711 green throttle resistor (left side of photo) and the other end to the #6714 brass bypass tab as shown. Now solder the black wire from the #6745 motor output plug to the negative terminal (right side of photo) on the #6711 throttle resistor.

This photo shows the wiper arm just entering the brake band portion of the throttle resistor. (right side of photo). The neutral position is the wider band just to the right of center on the #6711 resistor. In order to make adjusting of the throttle easier set your radio trigger servo trim adjustment for 70/30 (all top brand radios designed for cars have this feature).

Fig. 136 This is the position that the wiper arm is in at 1/2 throttle. These are the power bands on the resistor.

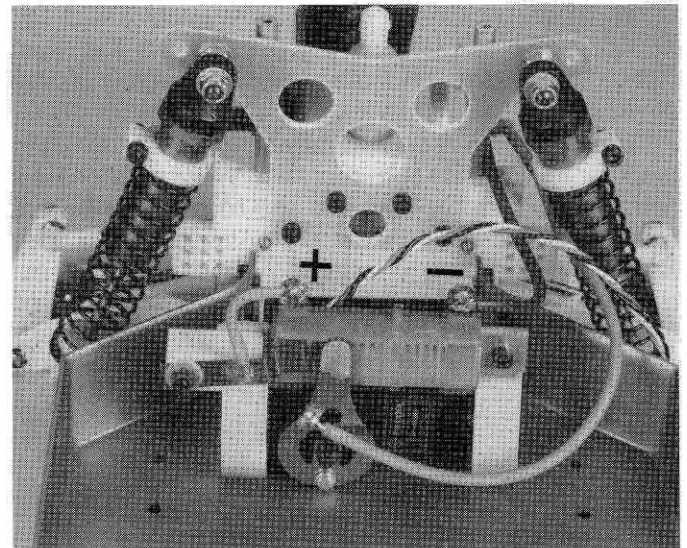

Fig. 136

□ **Fig. 137** This is the full power position of the wiper arm. It should be directly behind the bypass button and in the center of the wide band on the resistor.

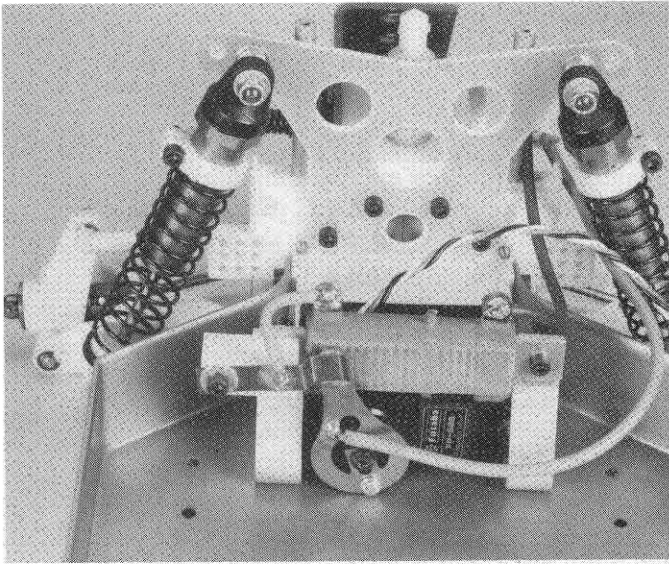

Fig. 137

□ **Fig. 138** The arrow is pointing to the space between the bypass button and the resistor band. This distance should be about .025 (.65mm) less than the thickness of the wiper button section, so that when the wiper arm button moves to full throttle it makes the bypass arm move about .025 (.65mm) forward. This bypass arm then helps to increase the pressure on the throttle wiper arm button, thereby giving it an excellent electrical connection. This, of course, allows the motor to achieve full horsepower and helps the resistor to last longer.

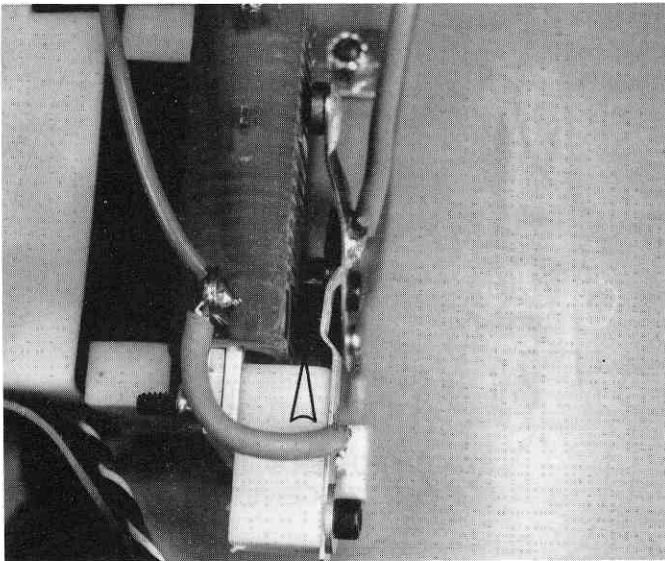

Fig. 138

WARNING: The current radio instructions are for the newer B.E.C. (battery eliminator circuitry) type radio systems. If you do not see these markings on the receiver or in the instructions you must assume that you have an older radio system that does not incorporate B.E.C. technology. If necessary, contact the manufacturer of your system and ask them. In these non-B.E.C. cases you must skip the instructions immediately following and go to the "Supplementary for non-B.E.C. radios" section on page 45.

□ **Fig. 139** We have installed the #6745 motor output portion of the wiring, now we will finish installing the #6747 battery/radio input power harness. It's in bag #6-13. Solder the larger red wire from the input power harness to the positive terminal of the throttle resistor (left side of photo), then solder the larger black wire to the negative terminal of the throttle resistor (right side of photo) Locate the on/off switch that came with your radio system. All name brand radios have gone to a standard plug system for the switch harness on B.E.C. radios. The small black and red wires on the power harness end in a small red male plug. This will plug into the female two pin plug end of the radio's on/off switch. The other male end of the on/off switch will plug into the radio receiver's battery socket. This setup will work for both 6 cell (7.2 volt) and 7 cell (8.4 volt) battery packs.

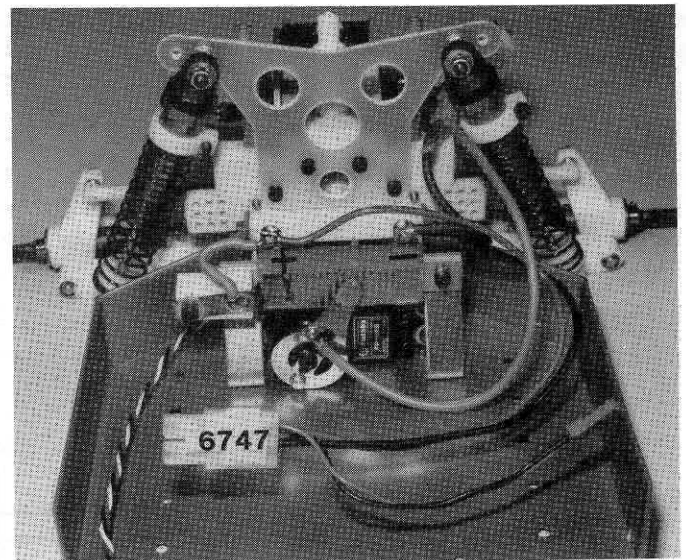
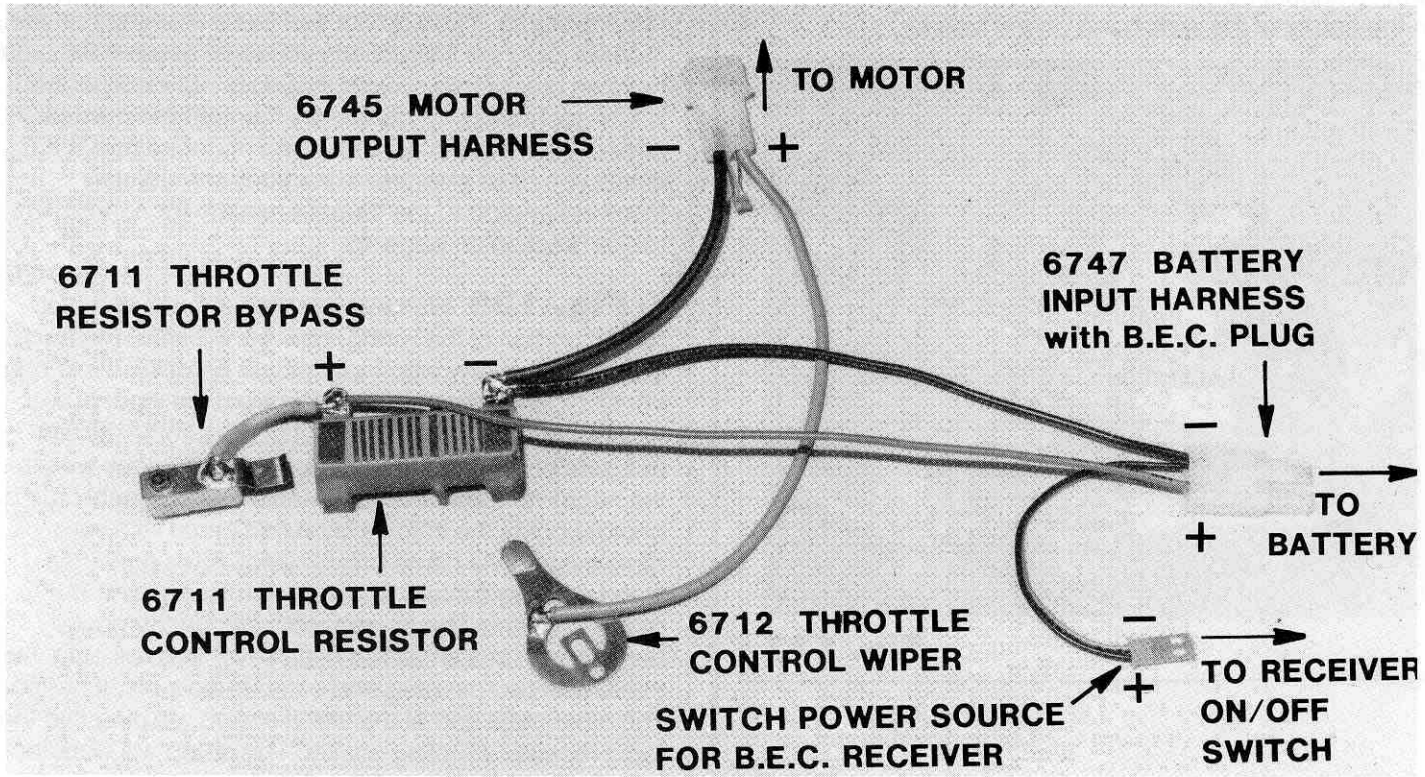
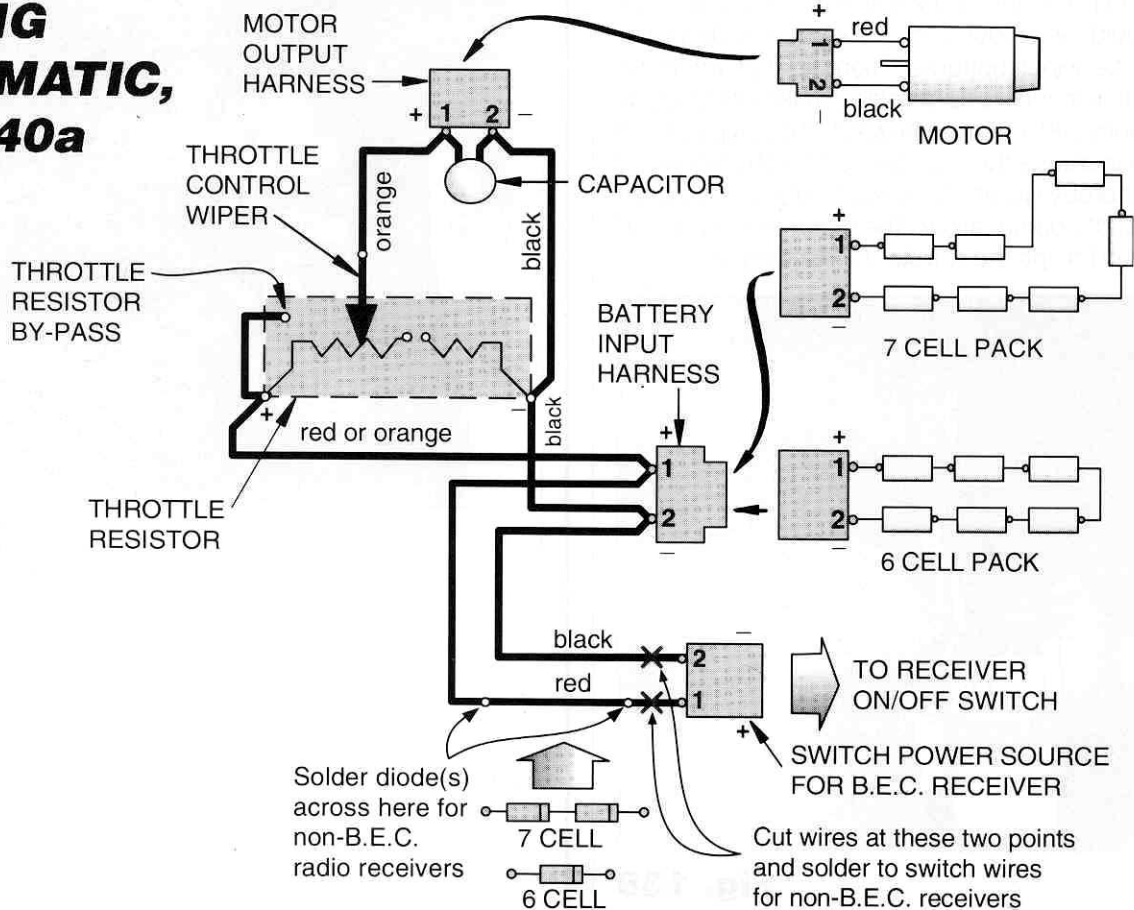

Fig. 139

WIRING DIAGRAM, Fig. 140



WIRING SCHEMATIC, Fig. 140a



Supplementary for non-B.E.C. radios

For radios which do not have B.E.C. receivers, the voltage coming direct from a 7.2 or 8.4 volt battery is too high and would damage the receiver. In order to use the battery pack as a power source for the receiver you will have to reduce the voltage from the battery pack to the receiver. We have included two diodes which will allow you to do this.

Now you must decide if you are going to run 6 cell or 7 cell battery packs because they will be wired differently. In bag #6-13 you will find a small plastic bag containing two #3715 diodes (see Fig.). If you are going to be running **6 cell (7.2 volt) batteries** you will only need one diode. Cut the leads on the diode so that there is only 3/8" remaining on each lead. With a **7 cell (8.4 volt) battery** you would use both diodes and cut both of them the same length on the leads. For **either type of battery** you will need to cut off the red plug from the small wires and the battery pack/plug from the on/off switch harness. See wiring schematic, fig. 140a.

CAUTION! Make sure that you do not cut off the receiver plug side of the switch harness. A safe way to make sure is to plug the switch harness into the battery plug slot of your receiver before you cut the other end off.

Now cut off the small red plug from the #6747 input power harness (fig. 140a). For a **6 cell battery** you will solder the diode to the small red wire of the input harness. Be certain that the stripe on the diode is on the switch side, not the battery plug side. For a **7 cell battery** you will solder the diode as you did for a 6 cell but you will solder another diode to the first one with the stripe on the switch side. See fig. 140b.

Now that both diodes are soldered to the harness, you can solder the red positive wire from the switch to the end diode on the red wire from the input harness.

□ **Fig. 140b** Now solder black wire from switch to black wire from input harness. Check each of your solder connections and then tape up the solder joints and diodes so that they cannot short out on the chassis. (NOTE: If you can get some small shrink tubing, this will make for a cleaner-looking finished part.)

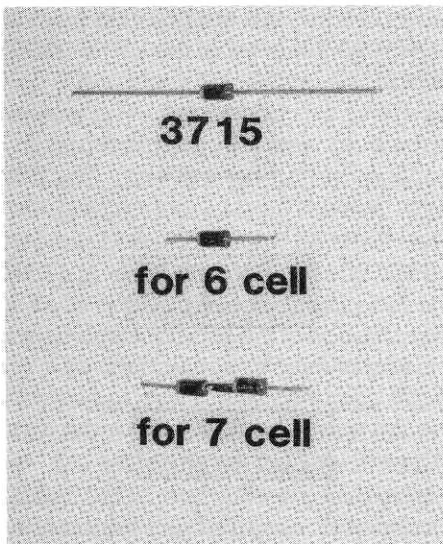

Fig. 140b

□ **Fig. 141** Open bag #6-7 and install the two #6334 battery trays to the chassis using four #6922 4/40 x 1/2" FHSScrews from the same bag. There are several sets of holes along each side of the chassis but you will only find four holes that are countersunk and will match up with the battery trays. In the same bag you will find two #6924 4/40 x 3/8" SHCScrews and two special #6929 4/40 x 3/8" SHCScrews with a hole cross-drilled through the head. The standard 4/40 x 3/8" SHCScrews will go in the holes on the battery trays closer to the transmission (or back of the car) while the special 4/40 x 3/8" SHCScrew (with the drilled hole) will be mounted in the two forward holes in the battery trays, where the arrow is pointing (see fig. 142). Do not tighten the screws all the way down. Leave them up about .065" (1.65mm).

Then in the two rear holes install the standard 4/40 x 3/8" SHCScrews, leaving them up about .085" (2.15mm). Now attach the on/off switch to the side of the chassis.

There is enough room for you to mount your receiver between the steering servo and the battery trays as shown. If you have either a large servo or receiver you can mount the receiver on its side in the same location.

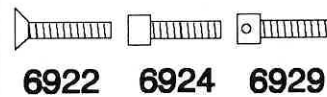
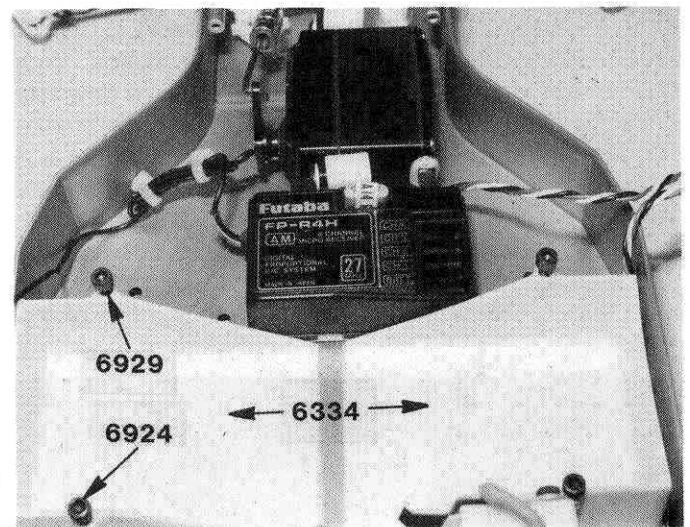

Fig. 141

□ Fig. 142 & 142a Where you mount the switch is really up to you. Just try and locate a place where you will be able to turn it on and off easily and not have it mounted so high it will hit the body. Stick it to the side of the chassis with servo tape as shown in fig. 142.

Plug the receiver plug side of your on/off switch into the battery plug slot on your receiver. The steering servo plug will go into the slot marked channel #1 (sometimes labeled rudder or "rudd"). The throttle servo will plug into the slot marked channel #2 (sometimes labeled throttle or "thro"). Use your radio instructions to check correct plug locations for your radio equipment.

Take the #6338 antenna tube and mount out of the kit bag. The small end of the mount with only one hole is where it will mount to the chassis. Insert the antenna tube into the other end using the larger hole. The tube will fit tight, but it will go in. Now push the receiver antenna wire up from the bottom of the mount through the antenna tube. Leave about 1" of wire sticking out of the top of the tube and tie a knot in it. Now attach the antenna mount using the #6922 4/40 x 1/2" FHSScrew that was with the mount.

NOTE: Most of the current brand name radios are using a longer length antenna wire (36" to 39") in order to improve reception as we move into the new FCC narrow band receiver rules for surface R/C radio systems. With these radios you will have excess antenna wire down by the receiver. The best way to handle this excess is to make a small rectangular piece out of cardboard or plastic and wrap the excess antenna wire around the plastic or cardboard. Do not let the wire wraps cross over each other as this can affect the tuned length of antenna wire and can shorten antenna range. See fig. 142a. You can then servo tape this portion of the antenna wire to the top of the receiver.

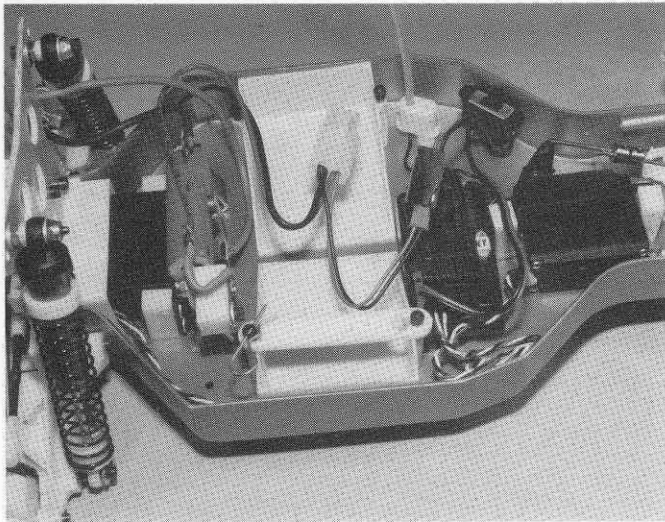
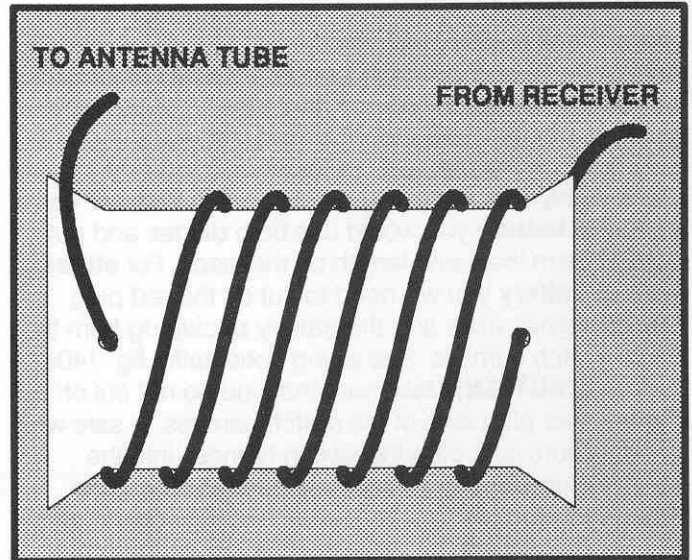

Fig. 142

There are a few extra holes in the bottom of the chassis which will not be used. You can cover these holes (from the top) with cellophane tape or the servo tape supplied with the car. A better choice is to use our new #6312 clear chassis protective sheet. This can be applied over the bottom of the complete chassis and helps protect the chassis's finish from damage which can occur under normal usage.



(DRAWING NOT ACTUAL SIZE.)

Fig. 142a

□ Fig. 143 We supply a battery charge cord set with this kit which will charge your 7.2 volt battery pack from any 12 volt DC car battery. **NOTE:** There is a separate charge cord available #6736 for 8.4 volt battery packs. **You cannot connect this charge cord with any other power source!** There are many good chargers on the market which will allow you to charge off of AC (household current) as well as 12 volt DC if you need that feature. In the main plastic bag you will find a bag with two large alligator clips some red and black plastic sleeves and two different types of wire. We are going to have to solder the alligator clips onto the ends of the wires. **NOTE: Do not shorten wires!** The arrows in the photo are pointing to the positive wire and clip connector. The positive wire is the silver appearing wire with the clear plastic coating on it. This coating can be hard to see. The black wire is negative wire. We will start by connecting the positive connector first. Take an Xacto knife and remove about 1/2" of clear plastic coating from the silver appearing wire. Now slide the red plastic sleeve over the silver wire. Insert the wire into one side of the alligator clip and solder it to the clip. On the end of the clip are two little tabs you will need to bend these over the coated wire to help relieve the strain from the solder connection. Take the red plastic sleeve and slide it down over the arm of the clip. Install the second red sleeve over the other arm of the alligator clip. Now repeat the process using the black wire and black plastic sleeves.

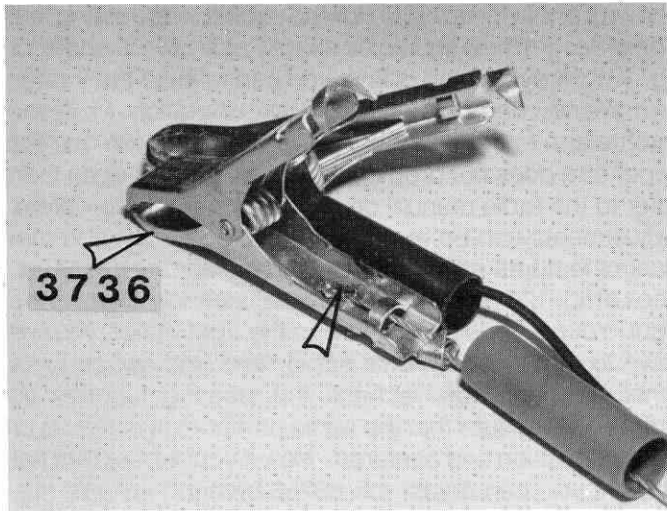

Fig. 143

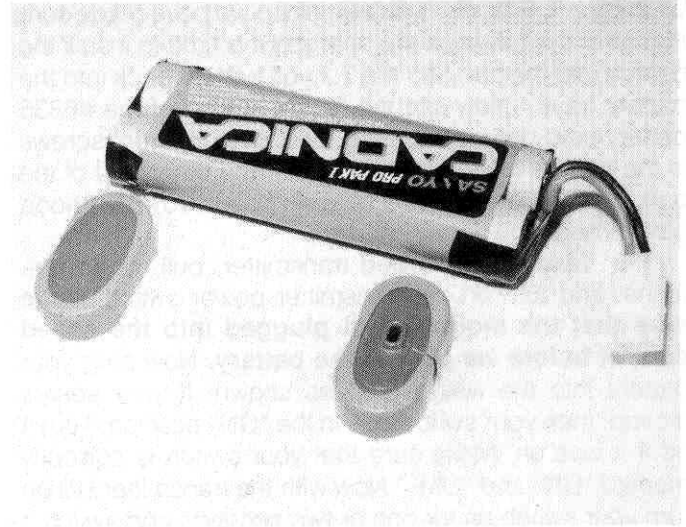

Fig. 144a

□ **Fig. 144, 144a & 144b** A change was made by the battery companies of placing plastic caps over the end of the batteries (fig. 144) for cosmetic appearance. These batteries will not fit into this RC10 with the caps still on the batteries.

Carefully cut the plastic shrink cover holding the end caps onto the battery and remove the caps (fig. 144a). The cap around the wires will have to be split in order to remove it from the wires without unsoldering the wires from the battery. Once you have removed the end caps you will need to place a piece of electrical tape over the ends of the battery and then wrap a piece of tape around the battery near the ends to hold this tape in place (fig. 144b).

We need to charge the battery pack now and check the radio transmitter batteries to make sure that they are charged. **NOTE: THERE ARE DETAILED CHARGING INSTRUCTIONS NEAR THE BACK OF THIS MANUAL ON HOW TO CHARGE BATTERIES IF YOU DON'T KNOW HOW.**

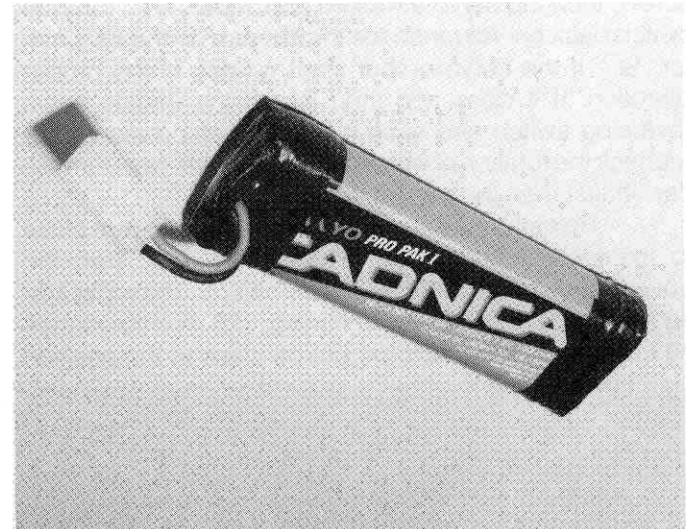

Fig. 144b



Fig. 144

□ **Fig. 145 & 145a** When we have made sure that all of the batteries are charged it is time to install the battery into the car. Slip the 7.2 volt battery pack into the battery trays. Now slip the "keyhole" end of the #6335 battery hold-down straps (fig. 145) over the front screws in the battery trays (fig. 145a). Slip the other end of the battery straps over the rear screws. Install two #6332 hood pins through the screw heads.

Take your charged transmitter, pull up the antenna, and turn on the transmitter power switch. **Make sure that the motor is not plugged into the speed control before we plug in the battery.** Now plug your battery into the wiring plug as shown. If your servos moved, then your switch was in the "ON" position. Turn it off if it was on. Make sure that your switch is correctly marked "ON" and "OFF." Now with the transmitter still on turn your switch on for one or two seconds and switch it back off. Refer to fig. 128 and see if your resistor arm is close to this position. If it is not, remove the servo horn screw, then the servo arm/horn and wiper arm. Turn the switch back on. Advance the throttle arm on the transmitter. See if the servo output shaft rotates in the proper direction. If it does not, then locate the throttle servo reversing switch and slide it to its other position. Now recheck the rotation of the servo output shaft. Now turn the car off first then the transmitter.

Reinstall the servo arm/horn and wiper arm close to the location shown on photo in fig. 128. Turn the transmitter back on and then the car switch. The wiper arm should be close to the position in fig. 128. Pull the throttle half way. The wiper arm should be close to the position

shown if photo for fig. 136. Pull the throttle all the way open. The wiper arm now should be exactly as shown in photo for fig. 137. If everything is fine, you can release the throttle arm. We now need to check the brake operation. Move the throttle arm to the full brake position. Make sure that the wiper arm does not drop off of the resistor. If it does then refer to the radio manual on how to correct the problem. Adjustments can be made using the end point and trim control features as in your radio manufacturer's manual. Look at fig. 121. Turn your transmitter steering wheel to the right. Your wheels should turn to the right. If not, you will have to move your throttle servo reversing switch to its other position. Now recheck the steering function as before. Make sure that the servo arm/horn is in the up or vertical position and centered. Now if your wheels are not straight you can adjust the #6256 steering linkage (fig. 121) to correct the problem. You can use the steering trim feature to fine tune the adjustments if necessary.

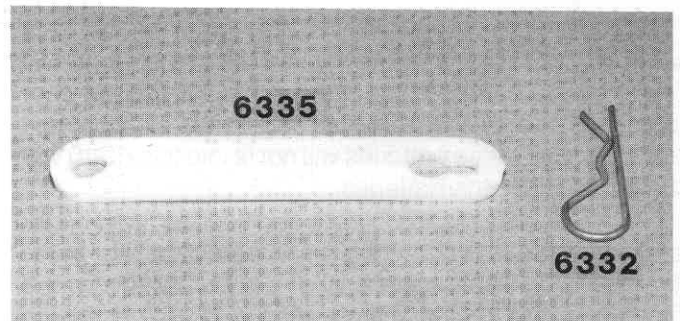

Fig. 145

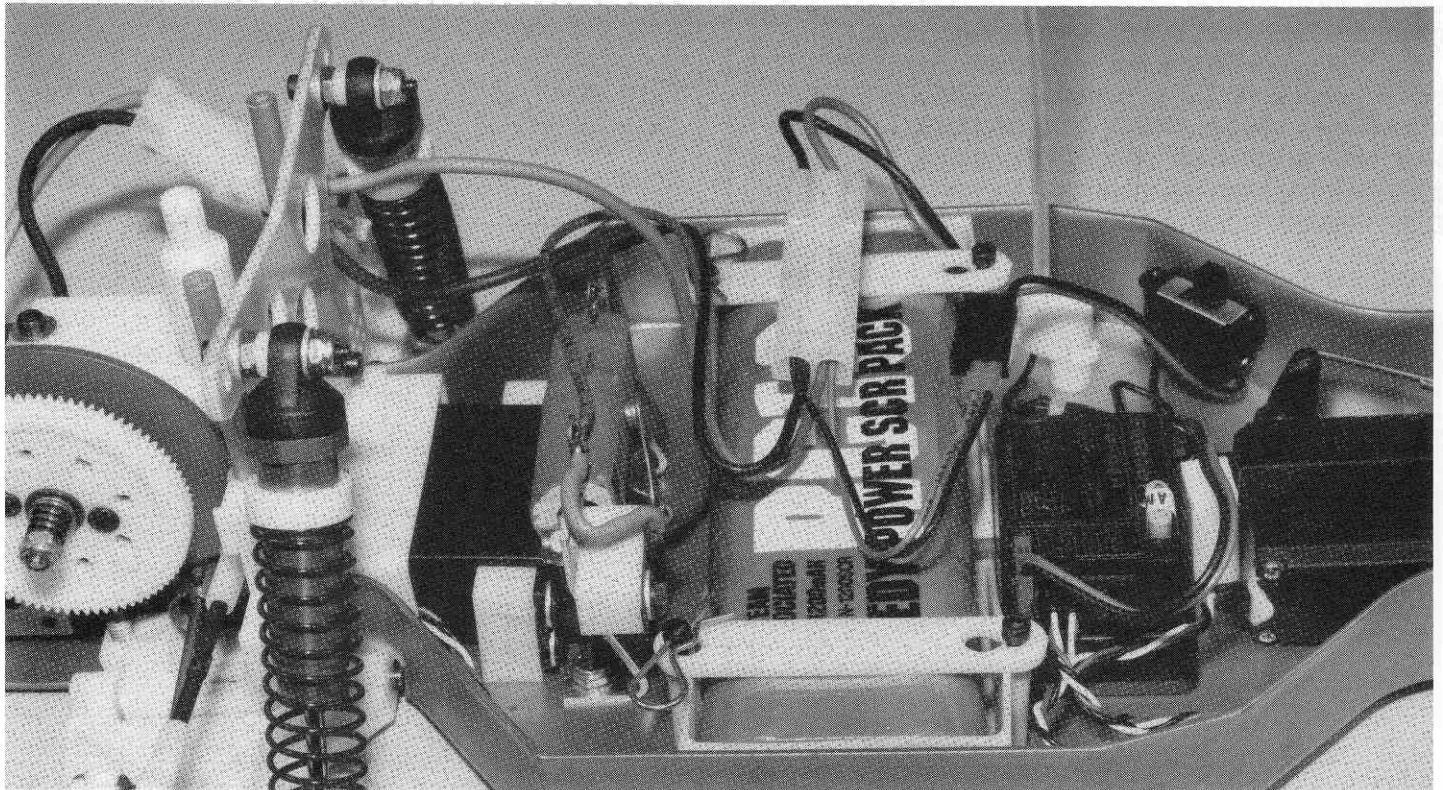

Fig. 145a

□ **Fig. 146** Turn the car switch off for a moment. Now plug in the motor to the speed control plug of the electrical system. Take a small wire tyrap and secure the plug to the wing tube with it. This will keep the wires away from the tires. Now make sure that the rear of car cannot touch the ground. Turn the car back on and slowly activate the throttle. Check for proper rotation of the axles then check for proper throttle operation. Now check the brake operation by moving the throttle arm in the reverse direction. If the brakes activate properly then you have everything setup correctly. Now turn the car switch off then the radio transmitter and you will need to unplug the battery pack from the electrical system as your final step. Your electrical system is done.

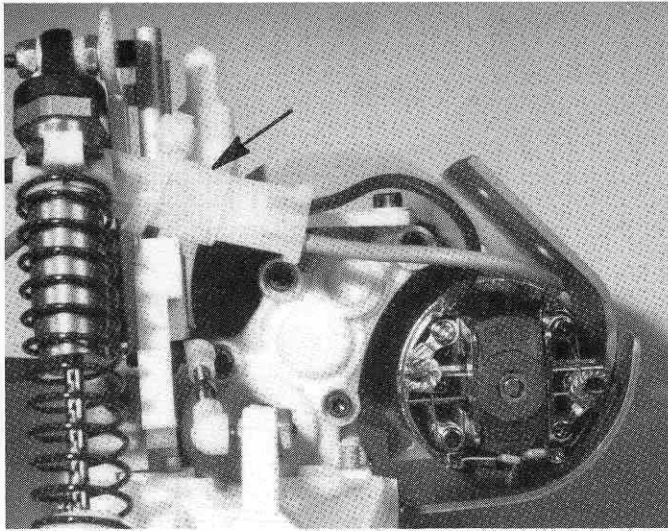

Fig. 146

WHEEL/TIRE ASSEMBLY

□ **Fig. 147** Take the #6854 front wheels and #6872 front tires out of the box. (NOTE: Tires in kit may differ from those shown in photos.) We want to put the large plastic ring inside the tire as shown. Work the ring into the tire until it is seated evenly. Tires vary a lot. Some will go on quite easily, and some will be quite difficult to install. On the tough ones, soapy water, like dish washing soap, will help the rubber to slip easier and will make mounting the tires much simpler. Be sure to rinse off the soap and then dry the tires thoroughly.



Fig. 147

□ **Fig. 148** This photo shows the #6872 front tire with the ring already installed. Make sure the ring is perfectly centered.

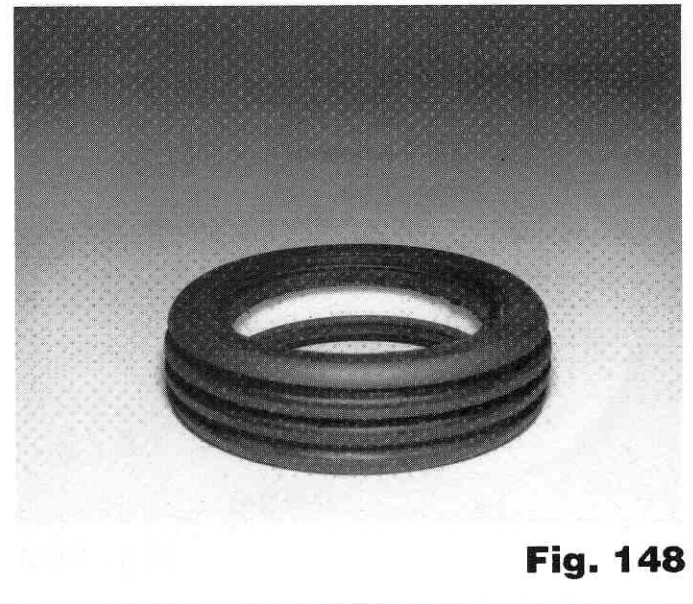

Fig. 148

□ **Fig. 149** Take the outer half of the #6854 front wheel (small center hole), as shown, and push it into the front tire making sure it is seated all the way around, and centered perfectly.

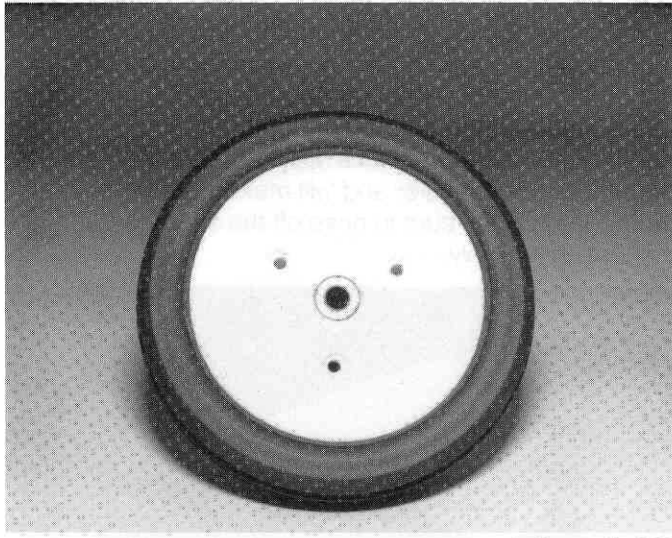

Fig. 149

□ **Fig. 151** Install the three #6861 4/40 x 3/8" SHCScrews. These are in the front wheel and tire bag. **DO NOT** overtighten these screws. Try to use the same tension on all three screws. Install the four #6864 wheel bushings. If you are installing bearings you will be using four #6906 3/16" x 3/8" plain bearings.

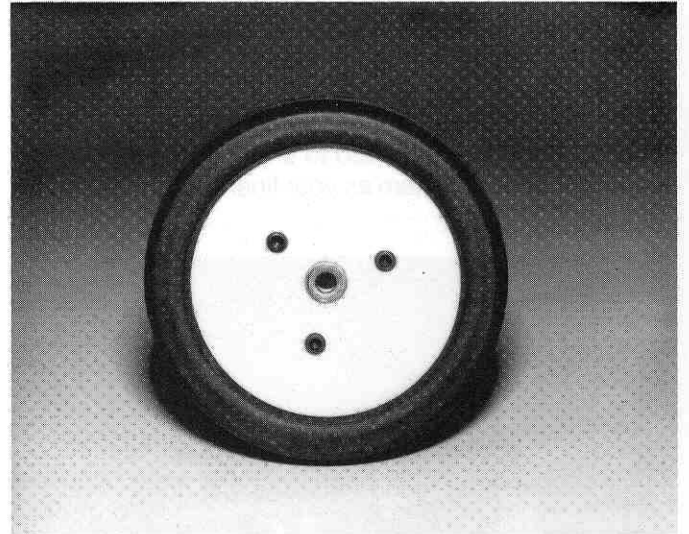
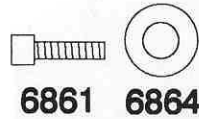

Fig. 151



□ **Fig. 150** Turn the tire over and install the inside half of the #6854 front wheel (large center hole). Make sure the screw holes are in line.

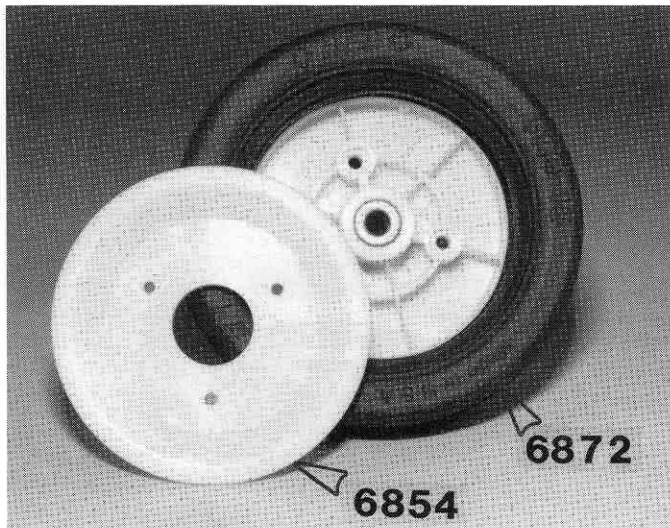

Fig. 150

□ **Fig. 152** If you have bushings oil them before you install the wheels onto the front axles. Spin the wheels and make sure that the tires spin true. If not, re-mount the tires as necessary. Now install the gold colored steel washer #3216 and one #6295 4/40 locknut on each wheel.

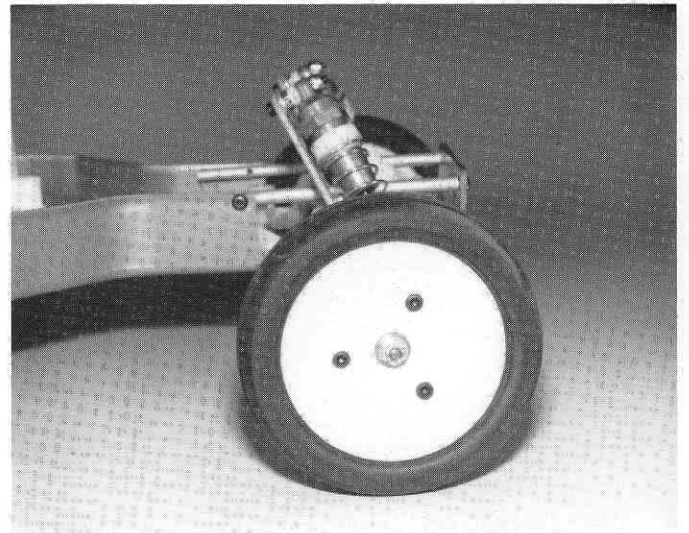
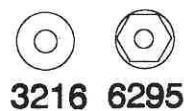

Fig. 152



□ **Fig. 153** From the rear tire bag take the #6822 rear tires and #6804 rear rims. Slide the wide plastic ring inside the tires.

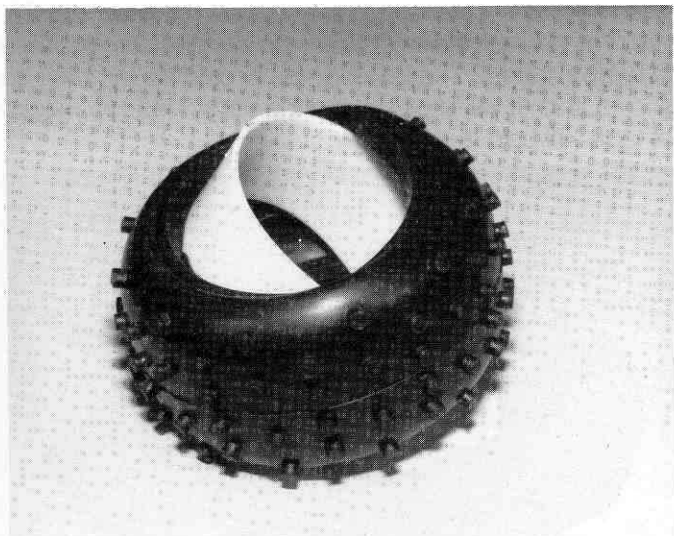

Fig. 153

□ **Fig. 155** Now take the outside half of the #6804 rear wheel (with the small center hole) and slip it inside one side of the tire as shown. Make sure it is centered and fully seated in tire. (Ignore the screws shown in the photo; we will put them in later.)

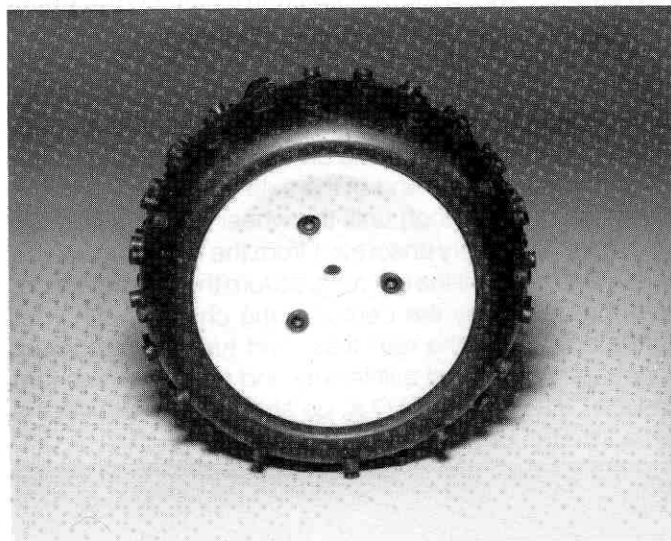

Fig. 155

□ **Fig. 154** They then should look like this.

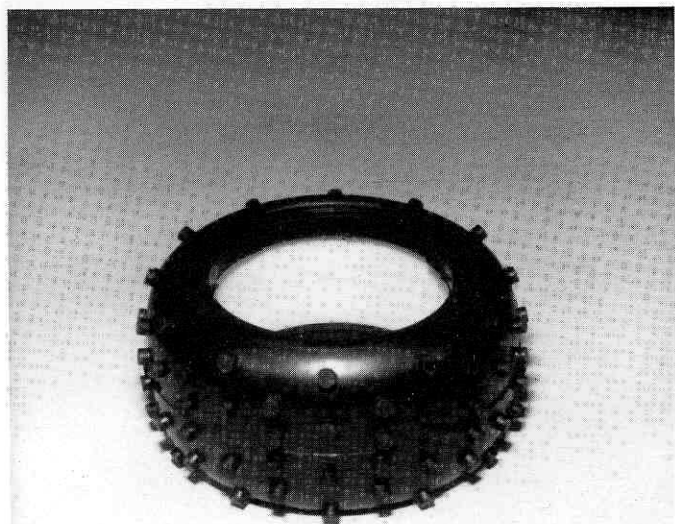

Fig. 154

□ **Fig. 156** Now take the inside half of the #6804 rear wheel (large center hole) and push it inside the open side of the tire, as shown. Make sure wheel half is fully seated and centered perfectly. Also make sure the screw holes are lined up. Install the 3 #6861 4/40 x 3/8" SHCScrew in each wheel. Do not overtighten.

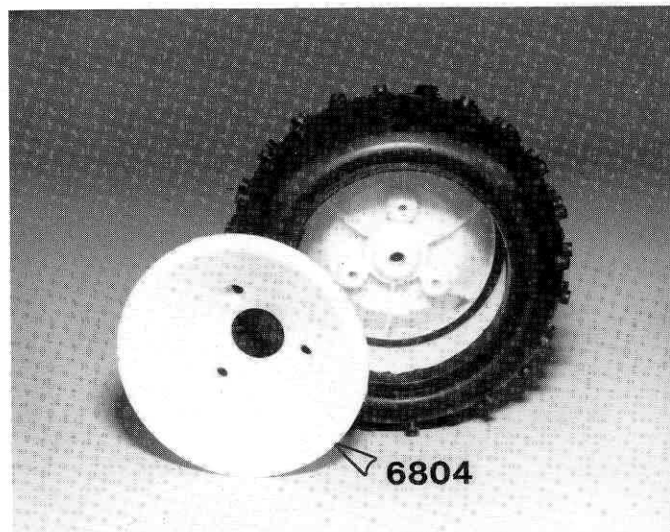
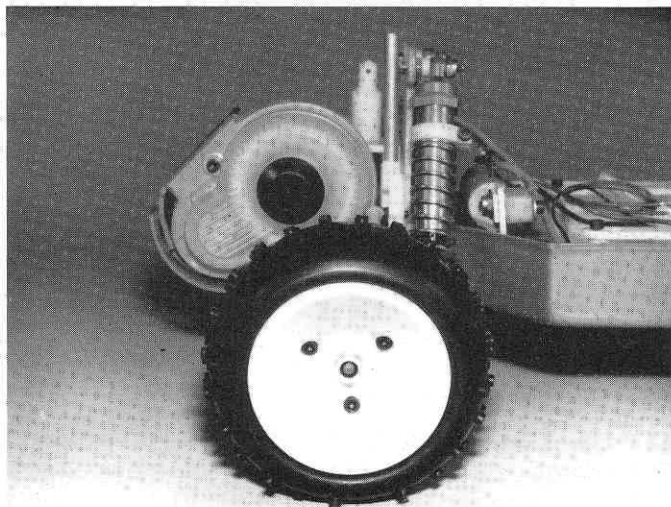

Fig. 156

□ **Fig. 157** Slip the tire and wheel assembly on the rear axle. If they go on tight, screw them on the axle making sure the slot in the wheel aligns with the pin in the axle. Some rear wheels will go on the axles a little tighter than others. Repeat the process with the other rear wheel and tire. Take the 2 #6296 8/32 locknuts and thread them onto the rear axles to secure the rear wheel and tire. You can install them with a pair of pliers but an 1 1/32" nut driver or socket would be easier. When you are ready to remove the wheels, take the locknuts off, hold the wheel from the backside and tap the end of the axle (preferably with the plastic handle of a tool) until the wheel moves a little bit. Then you can simply unscrew it from the axle. I know you cannot wait to see if the car runs, so turn the transmitter on, hold the car up by the center of the chassis, with your hands away from the rear tires, and turn the switch on. Touch the throttle just a little way and see if the tires turn forward. If everything is O.K. go ahead and play with the car a little bit, but be careful.



6296

Fig. 157

□ **Fig. 158** The #6180 clear lexan driver can be painted to look quite life-like. If you paint the helmet and visor on the inside, they will have a glossy appearance. Then if you paint the rest on the outside, it will be very life-like. You can use the small brush on paint bottles available in hobby stores. The lexan driver should be trimmed as shown, then it will slide up into the body, and two pieces of tape will hold it in place.

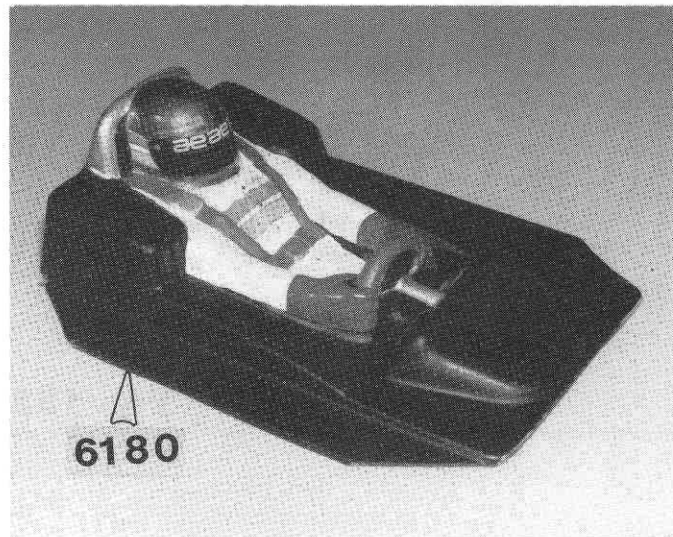

Fig. 158

□ **Fig. 159** The #6173 Protech II clear Lexan body can be painted before you mount it. However, it will be easier for you to mount it while it is still clear because it will be easier to locate the holes for the body mounts and wing tubes. This photo shows the trim lines for the front of the body and the front body mount hole.

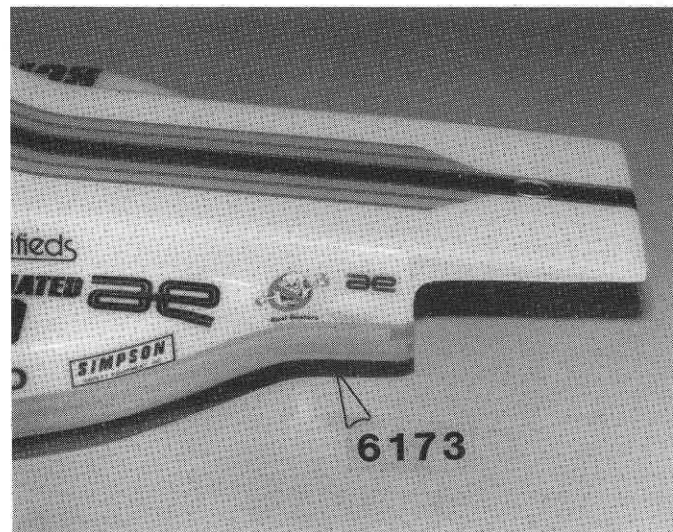

Fig. 159

□ **Fig. 160** The rear of the body must be trimmed like this to clear the shocks. NOTE: Save the trimmings to use for testing paint.



Fig. 160

□ **Fig. 161** Trim a little of the body and slip it on. Keep trimming a little at a time until it clears the shocks. Cut out the body mount hole and the two wing tube holes. **RACERS TIP:** Take a marking pen and mark the areas that you want to trim, then using an Xacto knife with a new blade score the lines you just marked on the body. You can then flex the body at the score lines and peel off the part you want to remove. When you have the body fitted, it's time to paint the body and wing. The body is painted on the inside and the wing is painted on the underside. There are 2 different ways to paint the body. By either brushing it on or spraying it on. The spray method will give you a more even finish but will cost more. The body is made of Lexan polycarbonate. In hobby shops, you can find special Lexan or polycarbonate paints made for these type bodies. This is the only kind of paint that you can use for brush application. One of the best brands of paint for this application is Pactra R/C Car Finish available in most hobby stores.

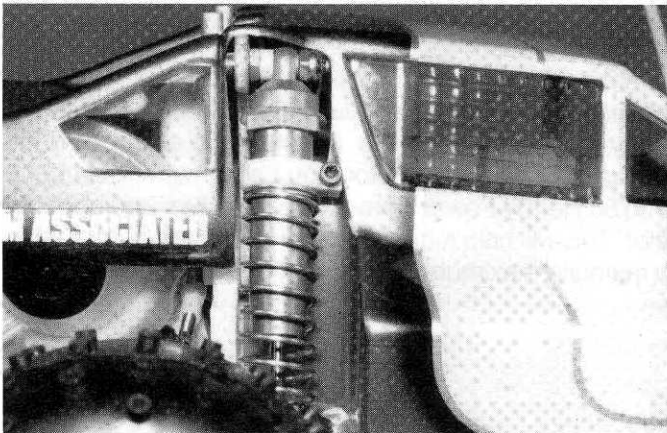

Fig. 161

□ **Fig. 162** Now you will have to figure out your paint scheme and mask the body off. Use automotive masking tape for best results. **PAINTING TIPS:** When painting, do the darkest color first, and the lightest color last, so the dark color won't 'ghost' through the light color. This means the first thing you mask off is the section which will be painted white. The next section you mask off is the lightest color next to white and so on.

There are several steps you can take to help insure that the finished product will be as good and long lasting as is possible. First make certain that the body is thoroughly clean. The more time spent on masking the body the better the final results. Take the time to press all of the tape edges down with your fingernail or the edge of a popsicle stick. Apply the paint in very thin coats, letting the paint dry between coats. **WARNING:** If the paint is sprayed on in heavy coats, the thinner in the paint stays liquid and attacks the Lexan which then becomes brittle and will crack easily.

After you have painted the darkest color, you peel off the next layer of masking tape and paint the next lighter color, and so on. When you paint the body put some masking tape on the outside of the body at the body mount holes, wing tube holes and shock cutout holes so the excess spray does not get on the outside of the body. If you make a mistake, the only product that can remove the paint or overspray without damaging the Lexan (if used properly) is Synthetic Reducer.

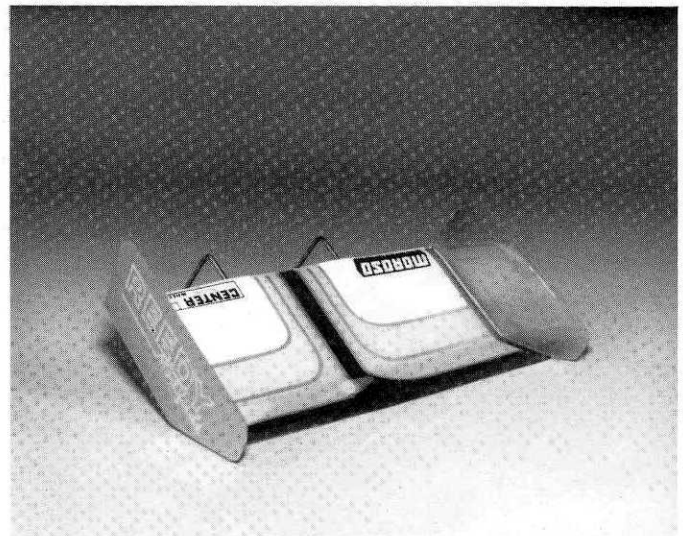

Fig. 162

□ **Fig. 163** Mount the #6182 wing as shown in the instructions in the wing bag.

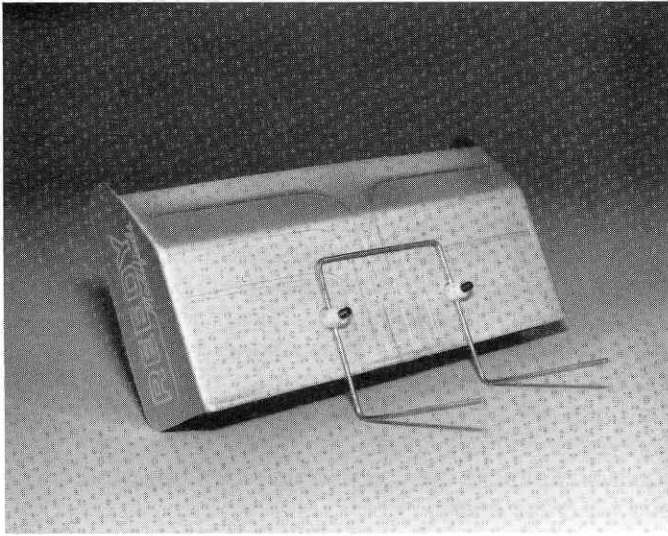

Fig. 163

□ **Fig. 164** Mount the body, with the #6332 body clips and wing, on the car, and then pat yourself on the back. **YOU DID FANTASTIC!!**

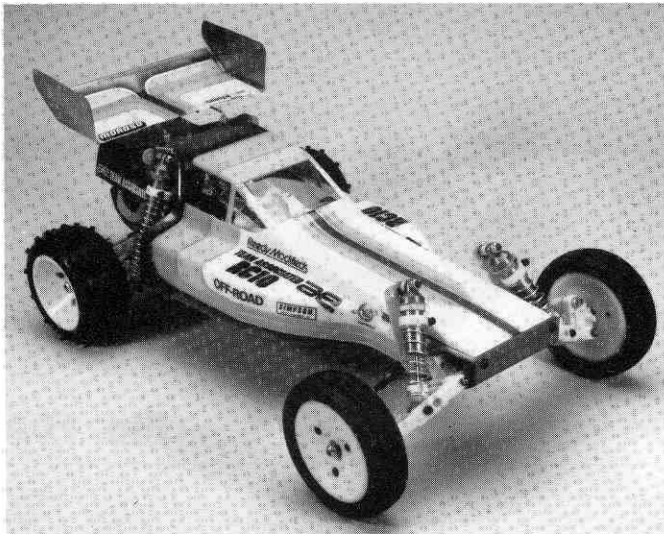

Fig. 164

RC10ce CAR MAINTENANCE

You'll find your RC10ce off road car will give you many more hours of trouble-free operation than any other car available now. You should periodically check all the moving parts: front and rear A-arms, steering blocks, steering linkage, shocks, and so on. If any of these should get any dirt in them and start sticking, it will greatly impede your car's handling. Keeping these parts clean will greatly improve their useful life and keep your maintenance costs down.

BUSHING MAINTENANCE. Keeping the front wheel and rear hub bushings cleaned and oiled is important to maintain your performance level. Also check the bushings for excessive wear and replace them when wear becomes apparent. Excessive bushing wear will create wear on other parts, increasing your maintenance costs.

WARNING: The Stealth transmission bushings are a special design and pre-lubricated. When cleaning or replacing the transmission bushings, do not use motor spray or any other chemicals. Wipe the excess oil and/or dirt from the bushings with a clean rag or towel before reinstalling. Putting additional oil on the bushings can allow the excess oil to contaminate the differential lube, causing the diff to slip.

MOTOR MAINTENANCE. Because we're running out in the dirt or on other surfaces with dust and debris, it is possible for this debris to give the motor problems. One of the first things to check are the brushes. Make sure they are able to move freely in the brush hoods. You can check this by pulling on the brush wire slightly so the brush will come away from the commutator, and seeing if the brush will snap back just on spring pressure.

You can clean the motor with #751 Reedy-in-a-Can motor cleaner. The best way to clean the motor is with the motor out of the car but still connected to the electrical system. With a battery in the car, carefully move the throttle resistor wiper so the motor turns at a fairly slow speed. Spray both ends of the armature where the shaft goes through the bushings and then spray the cleaner into the commutator area with the pinion shaft on the down side so the dirt and debris will flow out of the motor can. Move the spray around so the whole motor will be cleaned. Once you have cleaned the motor, you can spray a short burst of #750 Reedy Power Spray to the brushes and commutator. This will help lubricate the brushes and commutator to maintain maximum power.

For those of you who are planning to get into racing or just want more power, Associated offers Reedy Modified motors. For R.O.A.R. stock racing (where you are allowed to run only 24° timed motors), you can choose one of the Tru-stock motors #550 or #552. If you are racing in a stock class where they do not limit the timing (N.O.R.C.C.A. races are an example), you can choose one of the Mr. Outlaw stock motors #551 or #553. Reedy offers a large selection of Esprit and Ultra Torque modified motors to choose from. A good starting choice would be a #511 Ultra Torque Mr. "N" or a #6508 Esprit Ultimate 2 motor.

RADIO MAINTENANCE. A radio problem is not always caused by the radio. Often it is the result of a combination of factors which can include motor noise, poor electrical connections or wiring layout, reversed or defective crystals, weak transmitter batteries, and so on. If your radio problems persist, one of the following tips may help:

Make sure your motor noise capacitors are properly installed and making good electrical contact.

Make sure the brushes are free in their brush hoods, and when the motor is running, not arcing. Consider replacing brushes if arcing seems to be the problem.

Try a different frequency. If you are on the 75 mhz band, you cannot use Airtronics crystals in Futaba radios or the other way around.

Try a different motor.

Lengthen the standing portion of your receiver antenna and/or raise the antenna mount up to the rear shock strut.

Dress the radio wires well away from the power leads of the motor or battery. Keep the antenna wire away from any signal or power wires if possible.

Note also that 75 mhz band radios are more susceptible to interference. Large metal objects such as chain-link fences, light poles, cars, vans, or trailers parked near the track or practice area can cause local interference, particularly on the 75 mhz band.

CHARGING BATTERIES

It is important to understand the characteristics of the battery pack in your car because how you use it will greatly affect both its performance and its life. With proper care your pack will perform well for many hundreds of cycles.

The R.O.A.R. legal battery for your car is composed of six or seven "sub-C" size cells with a rated capacity of between 1.2-1.8 amperes for one hour, or 2.4 amperes for 1/2 hour, etc. This charge capacity is the same regardless of the number of cells in the pack because the cells are connected in series and the same current passes through each one.

CHARGER. A good quality charger will last longer for you than an economy unit, so please do not cut yourself short here by trying to save a couple of dollars. Any good name brand charger will do the job correctly. The more sophisticated chargers have extra features that make charging less time-consuming and can easily handle the abuse of heavy back-to-back type charging. The choice of a DC only or an AC/DC charger should be based on personal needs (where you will be using your car, etc.) and usage.

OVERCHARGE. There is no way to make a Ni-Cd cell accept more charge than it is designed to hold. This means that as the cell approaches a fully charged condition, the portion of charging current not being stored becomes heat and pressure. If charging continues after the cell is fully charged, all of the current is converted to heat and pressure—about 40 watts worth, or the equivalent of the heat produced by an average soldering iron. High temperature and pressure is damaging to the cells, so overcharging must be avoided.

Ni-Cd cells have a built-in process for recombining the accumulated gas (actually oxygen) produced by overcharge, but the process produces heat and takes a lot of time. If you overcharge your battery and it seems to take a long time to cool down, it's because this pressure reducing reaction is taking place. Once the gas is recombined the temperature drops.

HOW TO TELL WHEN YOUR CELLS ARE CHARGED

One of the problems with Ni-Cds is their inherent voltage stability; the voltage of a fully charged cell is not much different from one that's just about dead. For that reason several indicators, along with some common sense, are needed in order to get the most out of your battery. The following is a list of indicators you can use to detect full charge.

TEMPERATURE METHOD. This works only if you start with a cool battery pack. As the pack charges, frequently check its temperature by feeling the cells directly. As soon as you notice an increase in temperature, stop charging. If the cells become too hot to hold onto, your cells are excessively overcharged. Let them cool.

TIMED CHARGE METHOD. This works only if you have confidence in the timing accuracy of your charger. Many chargers on the market only approximate a constant charging current; they may vary from six amps when you first start charging, all the way down to two amps if the Ni-Cd pack is nearly charged and the voltage of the charging source (automobile battery) is low. If the charging current varies, it becomes difficult to estimate the average current. However, if your charger is reasonably dependable, you can use the following method.

Charge your pack using the "temperature method" above and keep track of the time required to reach full charge. Once you have established the time, you can use it as a setting for the timer on your charger. To be safe, use a setting about a minute less than what you established. This method allows you to charge without constantly monitoring the battery temperature.

If you charge a battery that is still hot from running, reduce the time about 20%. Then, after the pack has cooled, finish charging with the temperature method.

VOLTAGE METHOD. Voltage is a poor indication of a cell's state of charge. In fact, other factors like temperature, current drain, and "cell memory" have as much of an effect on voltage as the state of charge does. However, if current flow and temperature are held constant, it is possible to see the cell voltage gradually climb during the charging process. The absolute value of this voltage isn't of much use—how the voltage changes is an excellent indicator. To use this method, you will need a digital voltmeter or an expanded-scale voltmeter capable of resolving 0.01 volts on the 10 volt range.

Connect the voltmeter across the Ni-Cd pack, preferably right at the cell terminals, or, if that's not possible, across the terminals of the throttle control

resistor. Don't try to read the voltage at the output of the charger because you'll end up reading the voltage drop through all the connectors and cables between the charger and the Ni-Cd pack, which can sometimes distort the effect you're looking for. You should start with a Ni-Cd pack that is less than half charged. Connect your charger and begin charging at four amps. If your charger is adjustable, set the current now—but don't try to change it later. A constant current charger is preferable here, but if yours gradually drops off during charge, that's still permissible, as long as it doesn't drop below three amps.

Watch the voltage as the pack charges. Notice that the voltage at first climbs rapidly and in the middle of the charging cycle more slowly. This voltage will most likely be in the range of 8 1/2 to 9 volts for a six cell pack. As the pack approaches full charge, the voltage will begin to climb more rapidly; and as it goes into overcharge, the climb will slow down and then stop. This is where you stop charging—at the point where the voltage stops climbing. If you left the charger on, the voltage would begin to fall as the pack went deeply into overcharge and started to heat up. The maximum voltage reached will probably be in the nine to ten volt region; the actual value is unimportant.

When measuring voltage on NiCad cells, you must use a digital VOM (volt/ohm meter). A conventional analog scale VOM is not sensitive enough. By the time you see the needle move across the scale, you would have already damaged the battery cells.

SLOW CHARGE METHOD. Slow or "overnight" charging is a method you are not likely to use often, but it is a good way to bring the pack to absolutely full charge. However, the output voltage of a slow charged pack is slightly lower.

The charging current must be between 0.05 and 0.12 amperes. If less current, the pack will never reach full charge; any more and the pack will overheat. The time required to reach full charge ranges from 15 to 40 hours, depending on the current used. The charger can be left on for a much longer time without harming the cells; however, the output voltage of the pack will be temporarily lowered by an extremely long overcharge. The voltage returns to normal after a discharge-charge cycle.

These next two tips are really for the benefit of serious racers. If you're just out having fun, don't worry about them.

FULL DISCHARGE. Ni-Cd packs perform best if they are COMPLETELY discharged before they are charged. If you are involved in racing, you will have to do this if you expect to win any races! Discharge for at least an hour (preferably overnight with a clip-on resistor) before charging.

Associated Chargers have a discharge function. Various clip-on discharge resistors (about 30 ohms, 10 watts) are available at hobby stores.

TOPPING-UP can give you a little extra voltage at the beginning of a race, as long as you don't overdo it. Put the last minute or two of charge into your pack just before the race starts.

GOOD LUCK IN YOUR RACING!

CAUTION

Ni-cad batteries are susceptible to damage when overcharged at a high rate, and can release caustic chemicals if the overcharge is severe.

Do not stall the motor under power. If the car stops suddenly on the track, or fails to move forward when you attempt to accelerate, push the throttle control on your transmitter to the brake position immediately and attend to the car. A small rock can stall the gears, and if the throttle is left in the on position the result can be a burned out motor (or electronic speed control unit).

If you run your car to the point where more than one cell in the pack is completely discharged, it is possible to lose radio control of the car before the drive motor stops completely. For this reason you should not operate your car in an area where it could be harmed or cause harm, such as near a busy roadway or a pool of water. Usually radio control will be regained as soon as you pick up the car and the motor is allowed to free-run. If you still don't have control, then you should unplug the motor.

When you stop running your car, turn off the radio at the car first before turning off the transmitter.

A burned-out or shorted motor can make the car appear to have radio problems. If the car slows down suddenly and the radio acts erratically even with a full battery charge, then the cause is probably the motor. Check the range of the radio with the motor unplugged. A shorted motor will draw extremely high current even under no-load conditions.

SAVE THIS BOOKLET!

MORE THAN AN INSTRUCTION MANUAL, IT'S ALSO A HANDY, PICTORIAL SUPPLEMENT TO TEAM ASSOCIATED'S RC10 OFF ROAD CATALOG.

REFER TO THIS MANUAL FOR PART NUMBER AND NAME WHEN ORDERING.

RC10 CHAMPIONSHIP EDITION

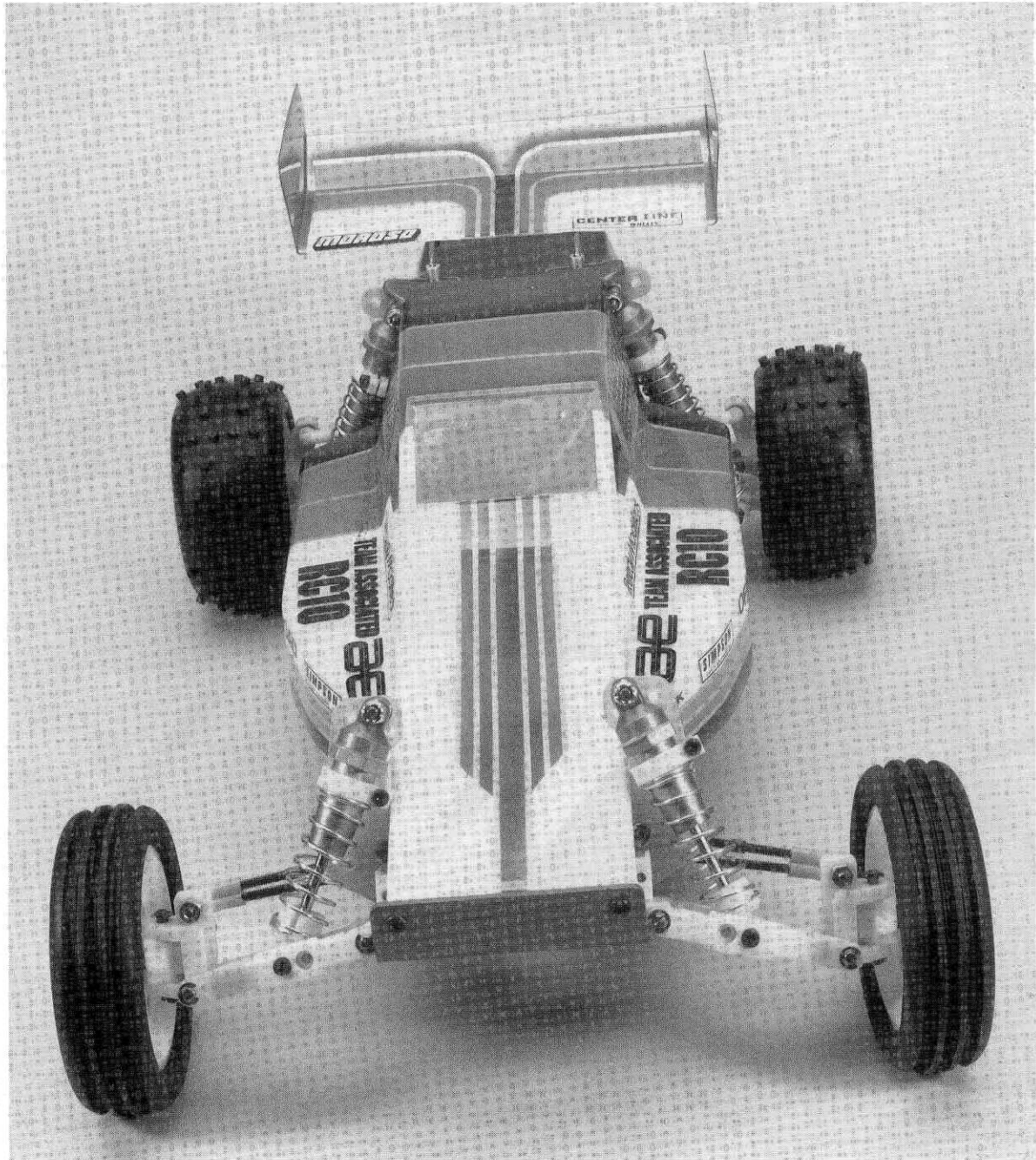

Associated Electrics, Inc.
3585 Cadillac Ave.
Costa Mesa, CA 92626 USA

