

RC10L2/RC10L20

NEW FEATURES

- New graphite chassis design.
- New composite material for front suspension parts.
- New front end brace.
- Fiberglass antenna rod.
- Graphite T-bar pivot brace.
- New symmetrical T-bar design.
- Improved T-bar performance.
- New molded dampener post.
- Improved dampener geometry.
- New roll stop limiters.
- New rear pod geometry.
- Redesigned composite left rear bulkhead.
- Redesigned aluminum motor bulkhead.
- New graphite dampener plate design.
- New rear lower pod plate design.
- New molded nerf wings

IMPROVED CAR PERFORMANCE

Using performance improvements we developed for the 1996 On Road World Championships, we moved the battery mounting position and added a brace to the T-bar pivots so that only the T-bar will flex under heavy load conditions. The new T-bar and T-bar spacer design improve the car's rear traction and rough track performance. Yet it still maintains the same side to side stiffness we wanted. We have relocated the dampener post location of the rear pod for consistency and performance. The new rear pod changes have lowered the motor's center of gravity, fine tuned the rear axle alignment, and made it easier to access the motor and solder it in. The roll stop inserts allow the car to respond to direction changes even quicker. We have also widened the battery slots of the RC10L20 on the left side of the chassis. This allows you to move the battery closer to or farther away from the center line of the chassis for different track and setup options.

RC10L2

#8015

ROAD EDITION

RC10L2

#8016

OVAL EDITION

TOOLS

KIT TOOLS SUPPLIED

- 1 Allen wrenches, .050", 1/16", 3/32"
- 2 shock assembly tool
- 3 shock/tumbuckle wrench

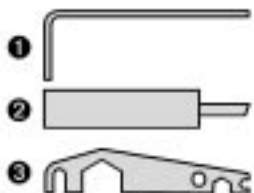

EXTRA TOOLS NEEDED

- 1 Phillips screwdrivers #2
- 2 needlenose pliers
- 3 soldering iron (40-50 watts) and a small amount of Rosin core solder. Pencil-type soldering iron is better than the gun type. **DANGER! Tip is HOT!**
- 4 Thread locking compound (#242 Blue Loctite® or equivalent)
- 5 hobby knife **WARNING! This knife cuts plastic and fingers with equal ease, so be careful.**
- 6 precision ruler
- 7 file
- 8 hand drill with 3/32" (or #43) drill bit
- 9 electrician's tape
- 10 strapping tape



LOCTITE **WARNING! Always use hand and eye protection with cyano-acrylic glue!**

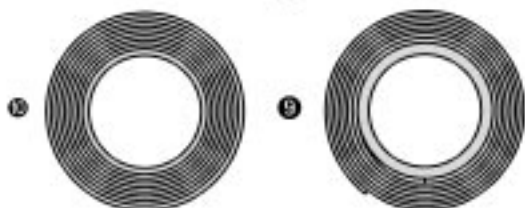

HELPFUL TOOLS (NOT REQUIRED)

- 1 Allen drivers (straight Allen wrenches with hex shaped handles) such as the following made by Associated:

- #6957 .050" Allen wrench
- #6958 1/16" Allen wrench
- #6960 3/32" Allen wrench
- #6961 2.5mm Allen wrench

- 2 Vernier calipers
- 3 Hobby scissors

- 4 Nut drivers (screwdriver-handled hex socket tools) such as the following from Associated:
- #SP-86 3/16" nut driver
 - #SP-85 1/4" nut driver
 - #SP-82 11/32" nut driver

WARNING! Do not use a power screwdriver to install screws into nylon, plastic, or composite materials. The fast rotation speed can heat up the screws being installed. They can then break or strip the threads during installation.

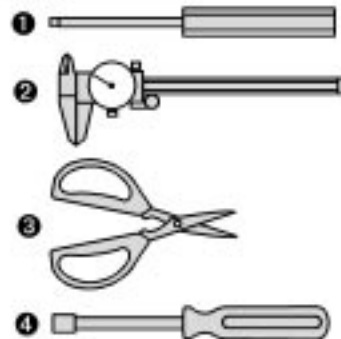

ITEMS NEEDED TO OPERATE YOUR CAR

- 1 R/C two channel surface frequency radio system.
- 2 *Battery pack (6 cell).
- 3 Battery charger (we recommend a peak detection charger).
- 4 *Electronic speed control.
- 5 *R/C electric motor.
- 6 *Pinion gear, size to be determined by type and wind of motor you will be using.
- 7 *1:10 scale Lexan body and wing.

* Available from Associated. See your 10L catalog.

REACHING US

CUSTOMER SUPPORT
 (714) 850-9342
 FAX (714) 850-1744



ASSOCIATED ELECTRICS, INC.
 3585 Cadillac Ave.
 Costa Mesa, CA 92626
 USA

©1997 Associated Electrics, Inc.

BEFORE BUILDING

OPEN THE BAGS IN ORDER

The assembly is arranged so that you will open and finish that bag before you go on to the next bag. **Sometimes you will have parts remaining at the end of a bag. These will become part of the next bag.** Some bags may have a large amount of small parts. To make it easier to find the parts, we recommend using a partitioned paper plate for spreading out the parts so they will be easier to find.

MANUAL FORMAT

The following explains the format of these instructions.

The beginning of each section indicates:

- 1 Which bag to open ("**BAG A**").
- 2 Which parts you will use for those steps. Remove only the parts shown. "**1:1**" indicates an actual size drawing; place your part on top and compare it so it does not get confused with a similar part.
- 3 Which of the two kits the parts will be used for, and for which steps they apply ("**Remove these parts for: 8015: step 1, 8016: step 1**").

- 4 Which tools you should have handy for that section.
- 5 In some drawings, the word "**REAR**" with an arrow indicates which direction is the rear of the car to help keep you oriented.
- 6 The instructions in each step are ordered in the order you complete them, so read the words AND follow the pictures. The numbers in circles are also in the drawing to help you locate them faster.

SUPPLEMENTAL SHEETS

We are constantly developing new parts to improve our kits. These changes, if any, will be noted in supplementary sheets located in a parts bag or inside the kit box. Check the kit box before you start and each bag as it is opened. When a supplement is found, attach it to the appropriate section of the manual.

Now clear off your workbench, line up some paper plates, grab your no-spill mug, double pattie hamburger, beef jerky, turn on some music, and let's begin!

BAG A

REMOVE THESE PARTS FOR:

8015: step 1

8016: step 1

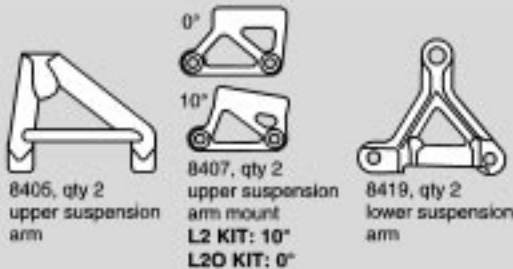

8415, qty 2
upper suspension
arm tumbuckle



8411, qty 2
upper suspension
arm eyelet



8409, qty 4
4-40 x 1/2"
shoulder screw

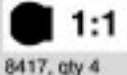

8417, qty 4
pivot ball

TOOLS USED



STEP 1 LEFT SIDE

ASSEMBLE UPPER SUSPENSION ARM

1 Assemble parts #8405, 8415, and 8411.

ATTACH UPPER ARM MOUNT TO LOWER ARM

2 Attach #8407 mount to the #8419 lower suspension arm using two #8409 screws. (**L2 kit: 10° mount, L2O kit: 0° mount.**) **WARNING!** Screws are difficult to screw in. Turn carefully so you do not strip out the head.

INSTALLING UPPER AND LOWER PIVOT BALLS

3 Before popping in the pivot balls, make sure there are no burrs inside the pivot ball holes.

4 Pop the #8417 pivot balls into the suspension arms as shown. Make sure that the shoulders of the pivot balls in the lower suspension arms are facing upward and the pivot balls in the upper arm are facing downward as shown. Orient ball to the rounded side of the upper arm as shown.

5 Now assemble the right side.

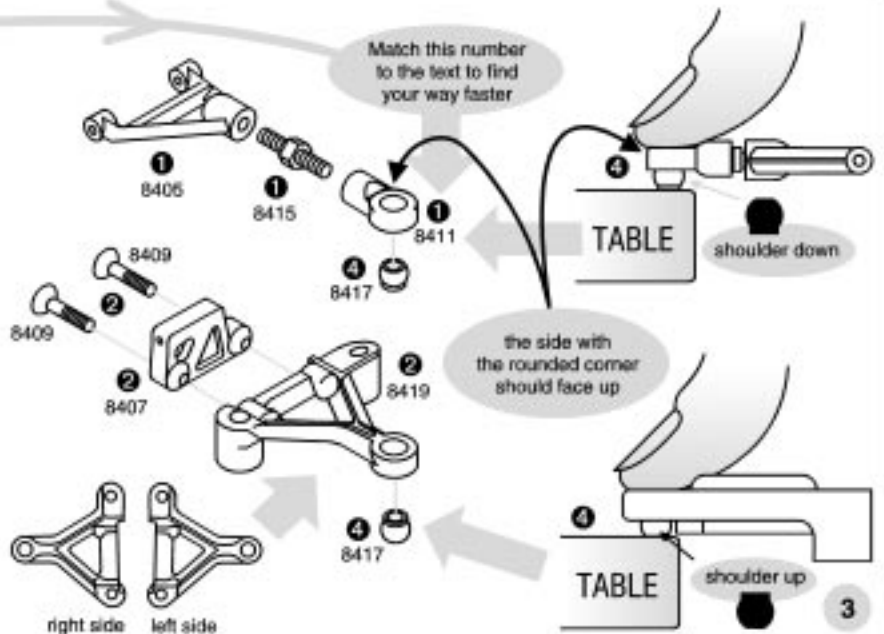

BAG A

REMOVE THESE PARTS FOR:

8015: steps 2-3

8016: steps 2-3

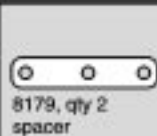

8179, qty 2
spacer



8439, qty 4
8-32 x 5/8



6917, qty 2
4-40 x 3/8

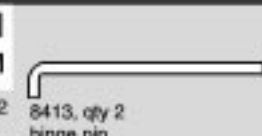

8413, qty 2
hinge pin



8413, qty 4
caster shims



L2O KIT ONLY
8403, qty 1
cross brace



6299, qty 8
E-clip



4448, qty 2
ball end

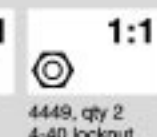

4449, qty 2
4-40 locknut



8429, qty 2
spring, .020



8425, qty 10
kingpin shim



8421, qty 2
offset steering
block

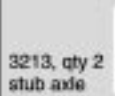

3213, qty 2
stub axle

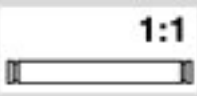

8423, qty 2
kingpin

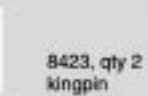

8423, qty 2
kingpin



8423, qty 2
kingpin



L2 KIT ONLY
8402, qty 1
cross brace

TOOLS USED

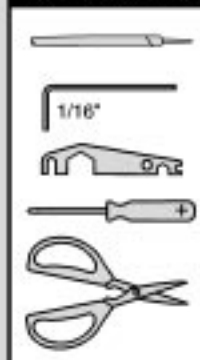

STEP 2

FILE THE CHASSIS

1 Use your file to bevel the slots on the top of the chassis so the edges won't cut through the battery cell wrap. **WARNING!** Graphite dust can be harmful to your health. File in a well ventilated area. Then wash the chassis with running water and dry with paper towels. Wash your hands afterward with cold water and soap. Deposit graphite filings in trash.

TAPE THE CHASSIS

2 Insulate the battery slots by wrapping the slots with electrical tape.

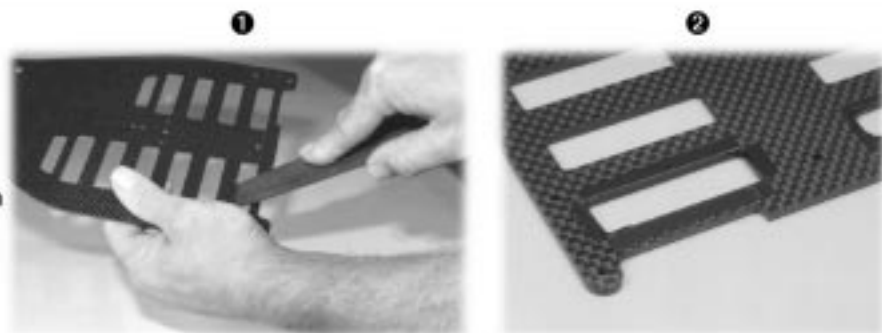

NOTE: The bottom of the chassis has the screw holes countersunk.

STEP 3 LEFT SIDE

SUSPENSION ARMS TO CHASSIS

1 Slip the #8179 spacer between the suspension arm and the chassis, then bolt on with two #8439 screws from underneath the chassis. Do the other side.

MOUNT THE CROSS BRACE

2 Mount the cross brace (L2 kit: #8402, L2O kit: #8403) to the front suspension using two #6917 button head screws.

UPPER ARM TO THE SUSPENSION MOUNT

3 Assemble the upper arm assembly to the suspension mount as shown, using the #8413 hinge pin and shims.

FINAL FRONT SUSPENSION ASSEMBLY

4 Assemble the #8421 steering block as shown using parts ##3213, 6299, 4448, and 4449. Install the ball end into the rear hole.

5 Place one #6299 E-clip on the bottom of the #8423 kingpin then slide the #8429 spring over.

6 Slide the #8423 kingpin completely through the bottom of the suspension arm and up through the steering block.

7 Place one #8425 shim on top of the #8421 steering block. Now push the upper arm over the kingpin. Place four #8425 shims over the kingpin and secure with a #6299 E-clip.

8 Do the other side.

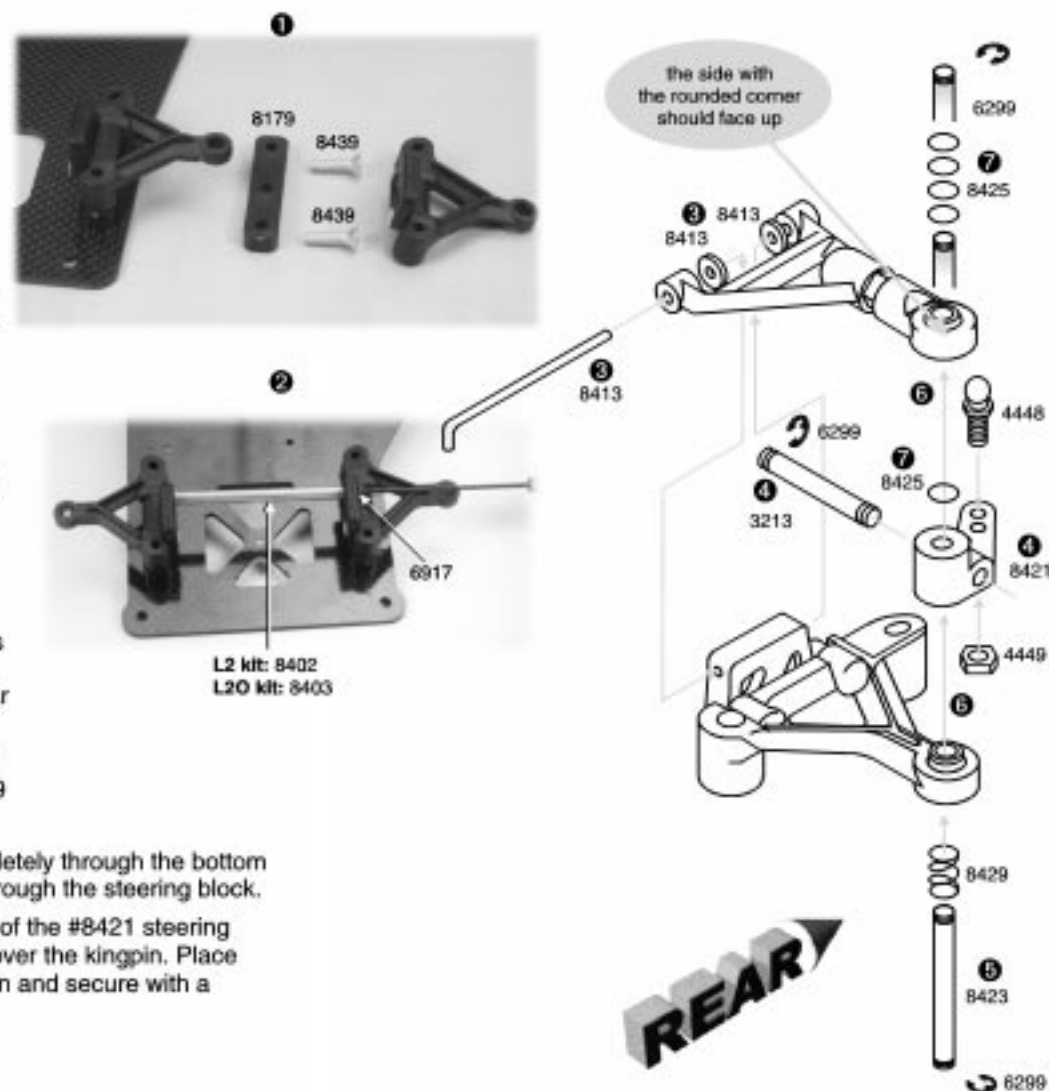

BAG B

REMOVE THESE PARTS FOR:

8015: steps 1-2

8016: steps 1-2



4335, qty 2 ea
pivot socket,
upper and lower



1:1
4334, qty 8
2-56 x 5/16



1:1
4436, qty 2
tweak set screw



1:1
4336, qty 2
pivot ball



1:1
6292, qty 7
4-40 x 3/8



1:1
4526, qty 2
T-bar spacer



1:1
4449, qty 2
4-40 locknut



4536, qty 1
left rear bulkhead



4537, qty 1
motor bulkhead



L2 KIT ONLY
8204, qty 1
lower pod plate

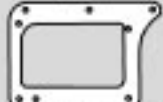

L2O KIT ONLY
8320, qty 1
lower pod plate

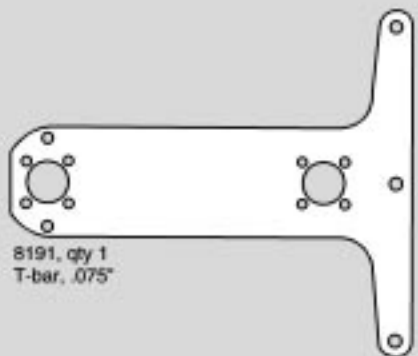

8191, qty 1
T-bar, .075"

TOOLS USED



.050", 1/16"

STEP 1 LEFT SIDE

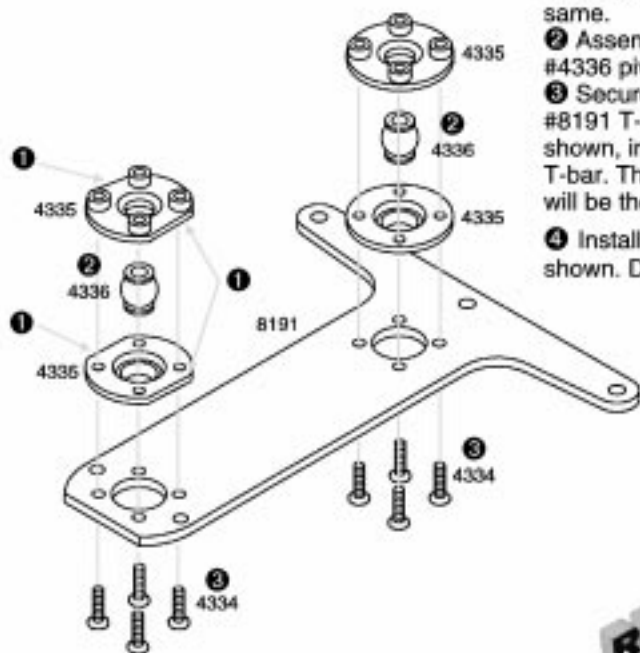

T-BAR ASSEMBLY

- 1 Trim the sides on the #4335 front pivot socket in order to make room for the T-bar tweak screws. The back rear pivot stays the same.
- 2 Assemble the #4335 T-bar sockets and #4336 pivot balls.
- 3 Secure the T-bar pivot assembly to the #8191 T-bar using four #4334 screws as shown, installing both on the same side of the T-bar. The side with the screw head showing will be the bottom.
- 4 Install the two #4436 tweak screws as shown. Do not overtighten the screws.

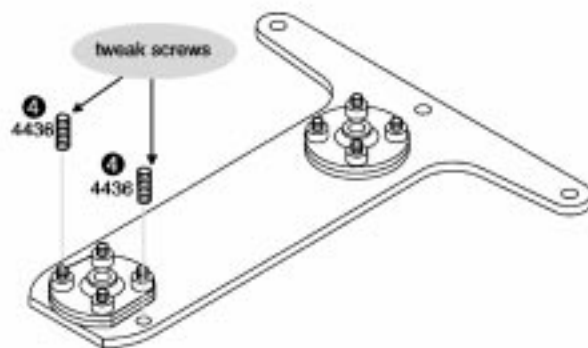

STEP 2 RIGHT SIDE

REAR POD ASSEMBLY

- 1 Bolt the lower pod plate (L2 kit: #8204, L2O kit: #8320) to the black #4536 left bulkhead and aluminum #4537 motor bulkhead with the five #6292 screws.
- 2 Attach the lower pod plate to the T-bar with #4526 spacers, #6292 screws, and #4449 locknuts. The spacer goes between the T-bar and the pod plate. The T-bar is on top.

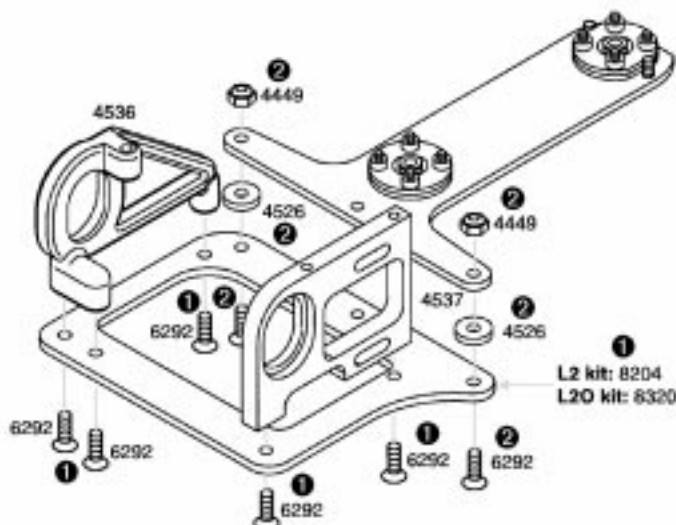

BAG B

REMOVE THESE PARTS FOR:

8015: steps 3-4

8016: steps 3-4

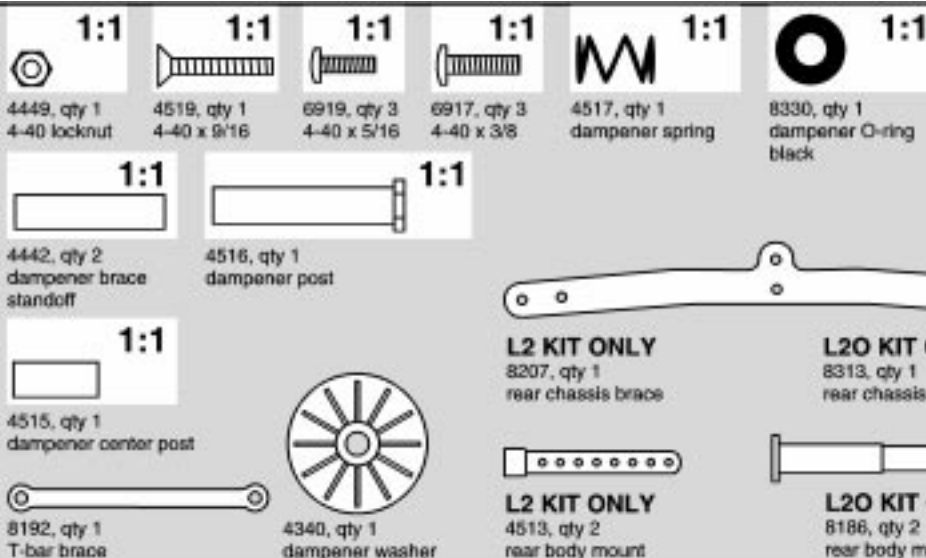

TOOLS USED

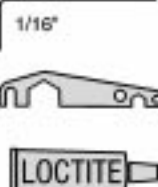

STEP 3 LEFT SIDE

T-BAR TO CHASSIS

- 1 Insert the #4519 screw through the chassis hole shown and into the T-bar.
- 2 Place the #8192 T-bar brace over the screw and secure with a #4449 locknut.

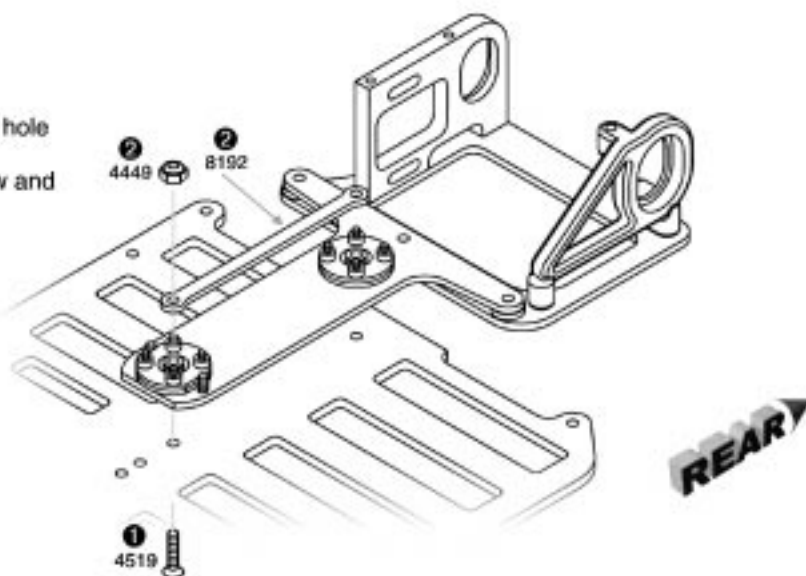

STEP 4 LEFT SIDE

REAR CHASSIS BRACE ASSEMBLY

- 1 Mount the aluminum #4442 and #4515 standoffs to the rear chassis brace (L2 kit: #8207, L2O kit: #8313) with the #6919 screws.
- 2 Mount the rear body mounts (L2 kit: #4513, L2O kit: #8186) to the rear chassis brace in the holes shown and secure the mounts using the #6917 screws.
- 3 Place a small amount of Loctite on the tip of a #6917 screw. Mount the #4516 dampener post to the rear chassis brace with the #6917 screw.

DAMPENER ASSEMBLY

- 1 Slide the #4517 spring, #8330 O-ring, and #4340 washer over the #4516 post in the order shown.

#8015 L2 KIT

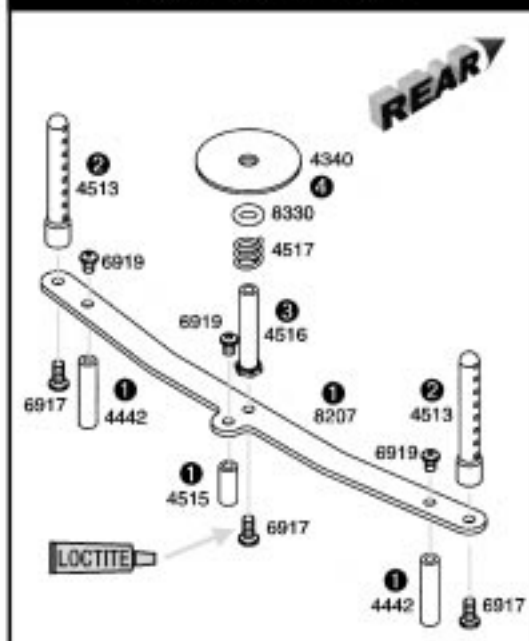

#8016 L2O KIT

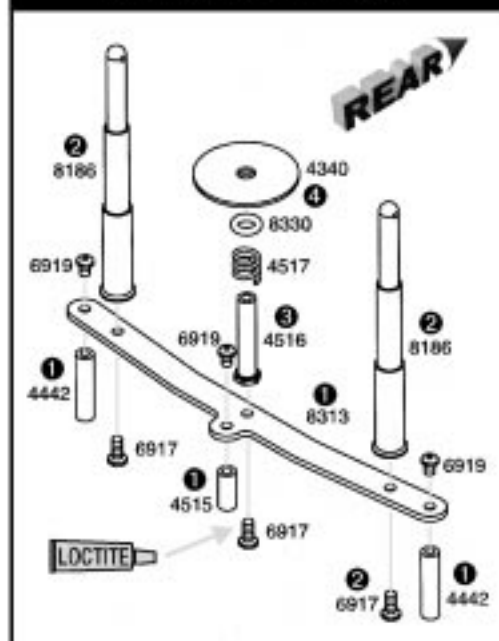

BAG B

REMOVE THESE PARTS FOR:

8015: steps 5-6

8016: steps 5-6



4518, qty 2
roll stop insert
OPTIONAL
see tuning section



1:1
6270, qty 1
4-40 ball end



1:1
6920, qty 1
4-40 x 3/16



1:1
8330, qty 1
dampener O-ring



1:1
4517, qty 1
dampener spring



1:1
6917, qty 1
4-40 x 3/8



1:1
6919, qty 2
4-40 x 5/16

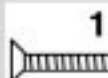

1:1
6915, qty 1
4-40 x 5/8



1:1
6292, qty 2
4-40 x 3/8



1:1
7673, qty 2
4-40 x 5/16



1:1
4449, qty 1
4-40 locknut



1:1
6466, qty 1
spacer



L2 KIT ONLY
8206, qty 1
dampener plate



L2O KIT ONLY
8316, qty 1
dampener plate



4340, qty 1
dampener washer



L2 KIT ONLY
8189, qty 2
molded nerf bar

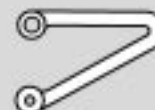

L2O KIT ONLY
8312, qty 1
molded nerf bar

TOOLS USED



STEP 5 LEFT SIDE

CHASSIS BRACE/NERF BAR MOUNTING

- Align the molded nerf bar(s) (**L2 kit:** #8189, qty 2. **L2O kit:** #8312, qty 1) over the rearmost chassis holes, the large hole of the nerf bar to the rear. Mount the bar to the chassis with the #6292 screw through the forwardmost hole of the bar.
- Push the outside aluminum standoffs through the rear hole of the nerf bars. Insert the #6915 screw up through the chassis and into the rear part of the T-bar, and screw it into the center chassis brace standoff tube.
- Secure the outside aluminum standoffs to the chassis with the #7673 screws.

#8015 L2 KIT

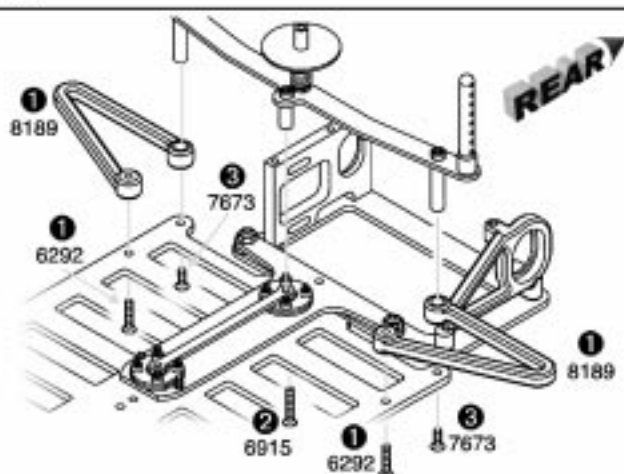

#8016 L2O KIT

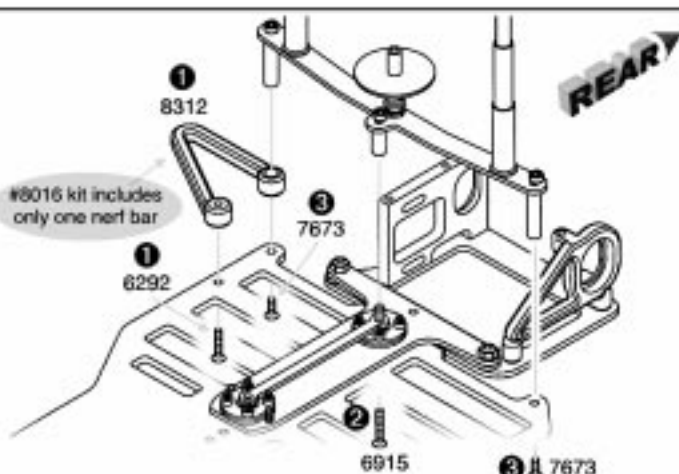

STEP 6 LEFT SIDE

DAMPENER PLATE ASSEMBLY

- Install the dampener plate (**L2 kit:** #8206, **L2O kit:** #8316) to the rear pod using two #6919 screws into the aluminum bulkhead and the longer #6917 screw into the plastic bulkhead.
- Slide the #4340 dampener washer, #8330 O-ring, and the #4517 spring over the dampener post as shown.
- Secure the dampener assembly using a #6466 1/32" spacer and #6920 screw.
- Install the #6270 ball end and #4449 locknut as shown.

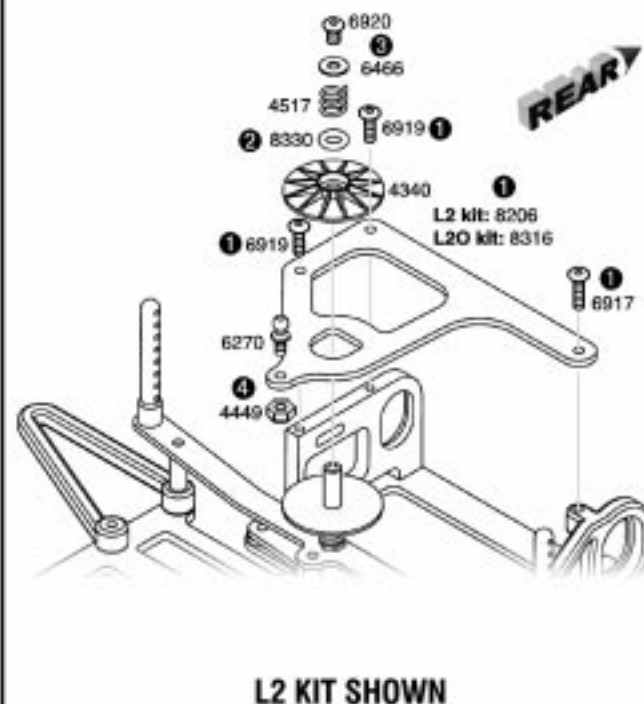

BAG C

REMOVE THESE PARTS FOR:

8015: steps 1-4

8016: steps 1-4

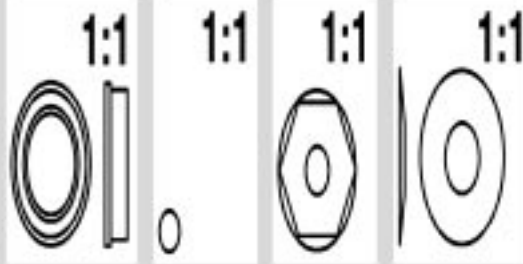

897, qty 4
1/4 x 3/8
flanged bearing

6626, qty 8
1/8" diff ball

4185, qty 1
8-32 locknut

8213, qty 3
Belleville washer

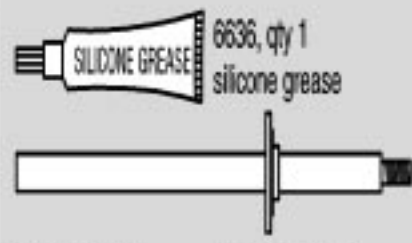

L2 KIT ONLY
8210, qty 1
graphite axle

L20 KIT ONLY
4355, qty 1
graphite axle

6636, qty 1
silicone grease



8212, qty 1
left wheel hub

TOOLS USED

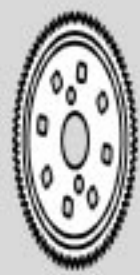

8282, qty 1
diff gear
81 tooth

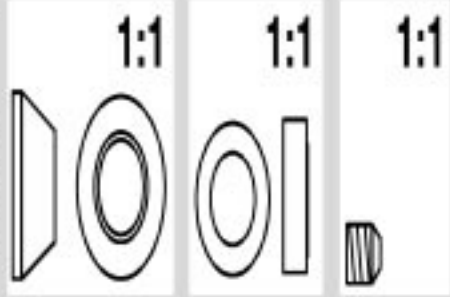

8213, qty 1
diff thrust cone

8321, qty 2
rear axle spacer

8212, qty 1
10-32 x 3/16
set screw

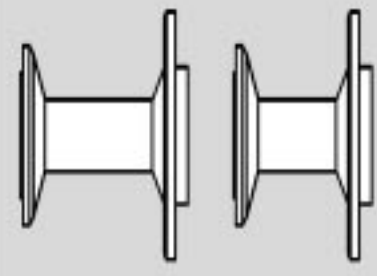

L2 KIT ONLY
8211, qty 1
right hand rear wheel/
diff spacer

L20 KIT ONLY
8322, qty 1
right hand rear wheel/
diff spacer



6625, qty 2
diff drive ring



4349, qty 2
ride height
adjuster, #1 UP

STEP 3

FINAL DIFF ASSEMBLY

- Hold the axle (**L2 kit:** #8210, **L20 kit:** #4355) upright and slide the #6625 diff ring over the axle and onto the aluminum hub of the axle.
- Slide the #8282 spur gear over the axle and center it on the hub.
- Apply a small amount of #6636 grease to the second #6625 diff ring as shown. Slide it over the axle, greased side towards the gear. This will keep the diff ring in place while assembling.
- Insert a #897 flanged bearing into each end of the spacer (**L2 kit:** #8211, **L20 kit:** #8322). Add a little #6636 grease to the smaller end, then slide the spacer over the axle.
- Install the #8213 cone so that the smaller end is facing the bearing. Place the three #8213 washers over the axle so that the smaller end faces away from the cone, and secure with a #4185 locknut. We will adjust the diff after we put the wheels on.

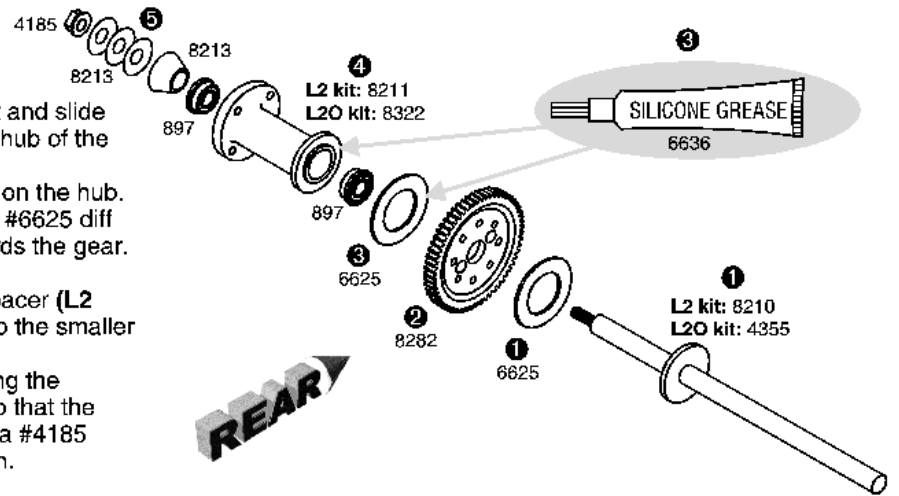

STEP 4

INSTALLING DIFF ASSEMBLY

- Slide one of the #8321 axle spacers onto the axle, shoulder away from gear.
- Slide the complete rear axle assembly through the motor bulkhead until it extends through the plastic bulkhead on the other side.
- Slide on the second #8321 axle spacer, the shoulder of the spacer facing the bearing.
- Install the #8212 left wheel hub onto the rear axle. Thread the #8212 set screw into the hub to tighten it to the axle. **Note:** To make sure the hub will not come off, file a small slot in the axle where the set screw would touch, as shown. We will adjust the diff after we put the wheels on.

SETTING THE AXLE END PLAY

- Make sure there is a slight (less than 1/32") amount of axle end play when tightening the left hub set screw.

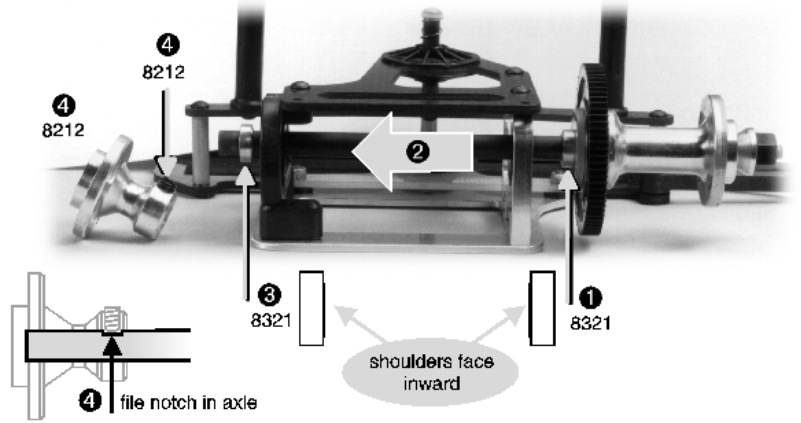

BAG D

REMOVE THESE PARTS FOR:

8015: steps 1-5

8016: steps 1-5



5407, qty 2 red O-ring

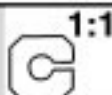

6440, qty 1 split locking washer

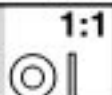

6440, qty 2 small washer



6440, qty 1 large spacer



6299, qty 2 E-clip



6922, qty 2 4-40 x 1/2



6274, qty 1 ball cup



6428, qty 1 shock cap



6464, qty 1 shock piston #1



6469, qty 1 large O-ring



5422, qty 1 30 wt silicone oil



8184, qty 1 shock/antenna mount



6438, qty 1 shock body



6461, qty 1 shock shaft



6429, qty 1 shock assembly tool

TOOLS USED

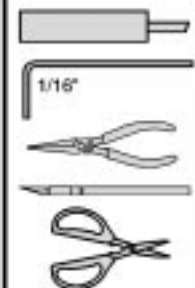

STEP 1 LEFT SIDE

SHOCK/ANTENNA MOUNT

- 1 Remove the shock cap bushing from the #8184 shock antenna mount.
- 2 Install the mount using two #6922 screws.

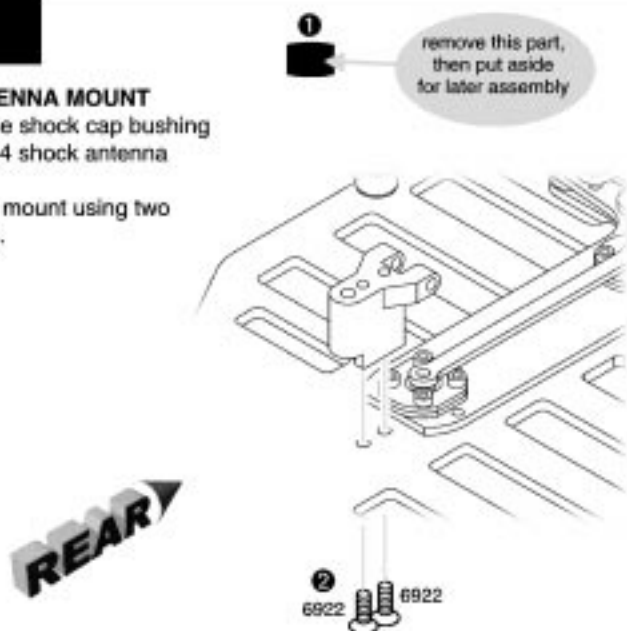

STEP 2

TRIM SHOCK PISTON

- 1 Burrs interfere with smooth shock action within the shock body. To remove from tree without creating burrs, twist up, not down. Remove one #1 shock piston.
- 2 Remove remaining burrs carefully with hobby knife.

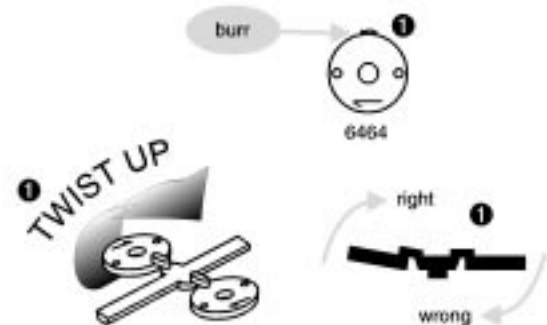

STEP 3

SHOCK SEAL PARTS

- 1 Install the #5407 and #6440 parts shown onto the #6429 tool tip.
- 2 Add 3-4 drops of #5422 oil to the inside of the #6438 shock body, and to the shock seal parts.
- 3 Insert the tool tip into the shock body all the way. Push **easily** until the parts snap into place.
- 4 Check the tool height in photo. The right shock shows just before snapping parts in place, the left shows after.
- 5 If your shock does not snap together easily, check the parts for burrs again.

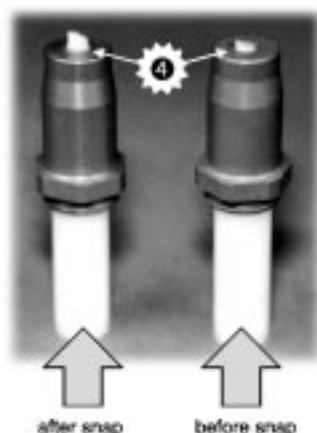
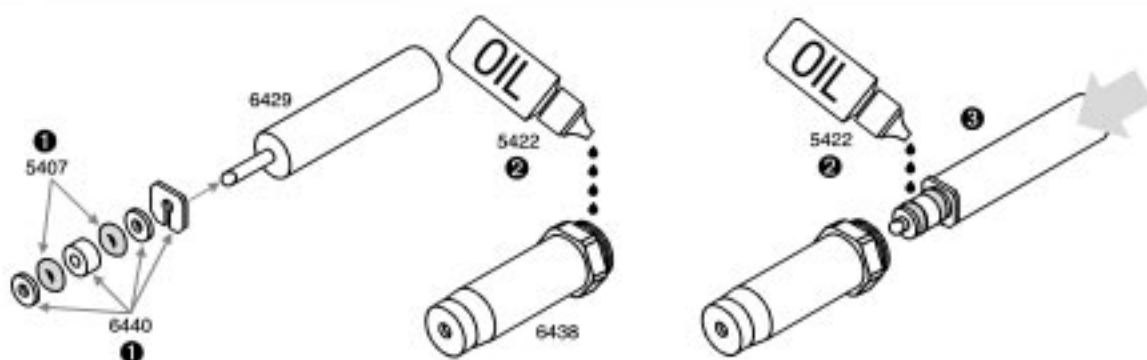

DISMANTLING THE SHOCK WHEN IT'S REBUILD TIME

- 1 Put the shock assembly tooltip into the bottom of the shock until it rests against the small washer, as shown, then push.

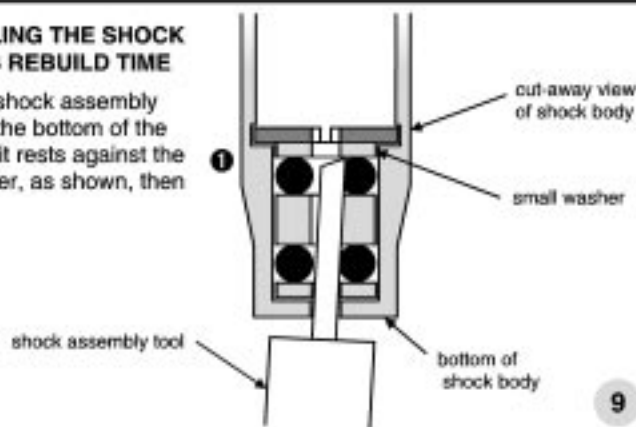

STEP 4

FINAL INTERNAL SHOCK ASSEMBLY

- 1 Add #6469 O-ring over threads of shock body.
- 2 Install a #6299 E-clip on either side of a #6464 (#1) piston.
- 3 Place a couple drops of #5422 oil on threaded part of #6460 shaft and insert into shock body.
- 4 Screw the #6274 ball cup onto the end of the shock shaft, holding the shaft with rag and needlenose pliers next to threads.

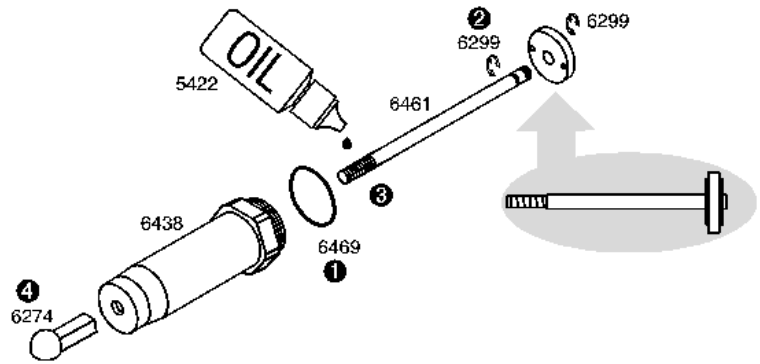

STEP 5

FILLING THE SHOCKS

- 1 Holding the shock upright, fill with oil to the top of the shock body.
- 2 Slowly move the shaft up and down several times to allow air bubbles to escape to the top.
- 3 Refill with oil to the top of the shock body.
- 4 Push the shaft all the way up into the shock body. The oil will slightly bulge up above the shock body.
- 5 Install the #6428 shock cap and tighten. There should be no gap between the cap and the hex portion of the shock body when tight.

SETTING THE REBOUND

- 6 Move the shock shaft in and out a few times, then push it all the way in. It should be easy to push the shaft in until the ball cup hits the body.
- 7 Then the shaft should push itself out approximately 1/4" to 3/8" (6.3mm - 9.5mm").
- 8 If the shock does not push out this far, there is not enough oil in it. Add just a little oil and try steps 6-7 again.
- 9 If the shock pushes out farther than the distance in step seven, or you cannot push the shaft in until the ball cup hits the body, there is too much oil. Loosen the cap a half turn (with the shaft extended) and pump out a small amount of oil by pushing the shaft in. Retighten the cap and try steps 6-7 again.

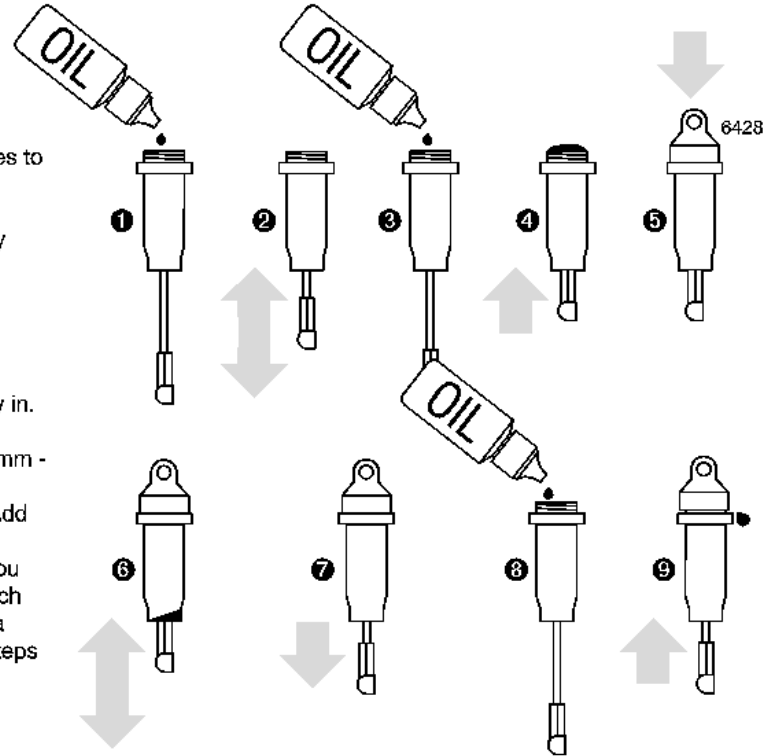

BAG D

REMOVE THESE PARTS FOR:

8015: step 6

8016: step 6



6474, qty 1

6474, qty 1

6474, qty 1



6932, qty 1



8232, qty 1



6496, qty 1

1:1

L2 KIT ONLY

L20 KIT ONLY

TOOLS USED

3/32"

STEP 6

FINAL SHOCK ASSEMBLY

- 1 Pull the shock shaft out as far as it will go.
- 2 Start the #6932 screw into the #6474 spring clamp, then slide the clamp up the shock body as far as it will go.
- 3 Slide on the spring collar, then spring, then spring cup, orienting them according to the drawing.
- 4 Adjust the spring clamps to the dimensions shown. Next tighten the #6932 screw to hold them there.

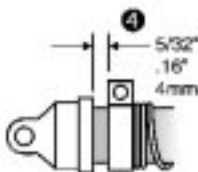

DRAWING NOT ACTUAL SIZE

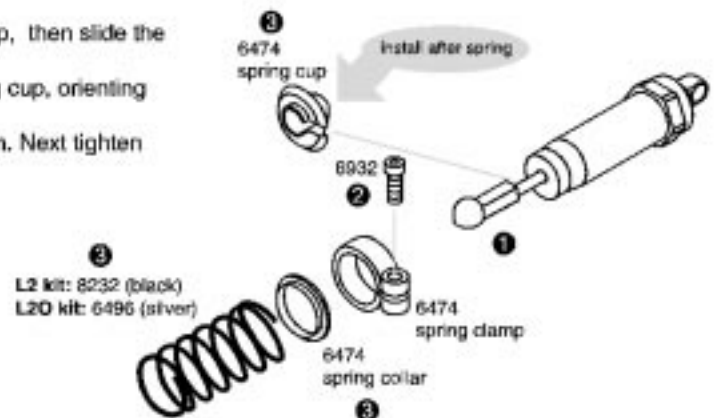

L2 kit: 8232 (black)
L20 kit: 6496 (silver)

6474 spring clamp

6474 spring collar

BAG D

REMOVE THESE PARTS FOR:

8015: step 7

8016: step 7

1:1



6926, qty 1
4-40 x 5/8

1:1



8184, qty 1
shock cap
bushing

TOOLS USED

3/32"



STEP 7

MOUNT THE SHOCK

- 1 Pick up the small bushing you had removed from the antenna/shock mount and insert it into the shock cap.
- 2 Install the shock cap and bushing into the antenna mount and secure using a #6926 screw.
- 3 Snap the rear of the shock onto the ball end as shown.



BOX

REMOVE THESE PARTS FOR:

8015: step 1

8016: step 1



3655, qty 4
1/8 x 5/16
flanged ball bearing

1:1

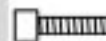

6924, qty 8
4-40 x 3/8

1:1



4187, qty 2
washer

1:1



6299, qty 2
E-clip

1:1



8165, qty 2
rear wheel/tire



8141, qty 2
front wheel/tire

TOOLS USED

3/32"



STEP 1

MOUNTING REAR TIRES

- 1 Install both #8165 rear tires to the hubs with four #6924 screws into each wheel hub.

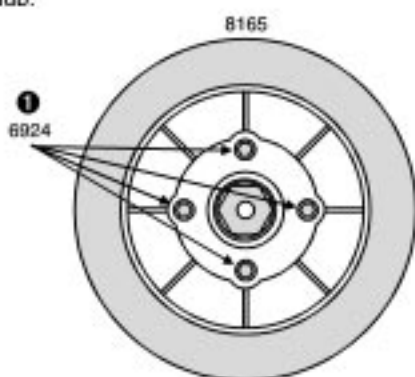

SIDE VIEW SHOWN

MOUNTING FRONT TIRES

- 2 Look at the spoked #8141 front wheel closely. Notice that one side of the wheel hub has indentations (see picture) that will seat the flange of the ball bearing. That indented side will face toward the chassis. Put a #3655 flanged ball bearing into each side of the front wheels.
- 3 Place a #4187 washer over the axle, then slide the wheel on and secure it with a #6299 E-clip. Install the other wheel the same way.

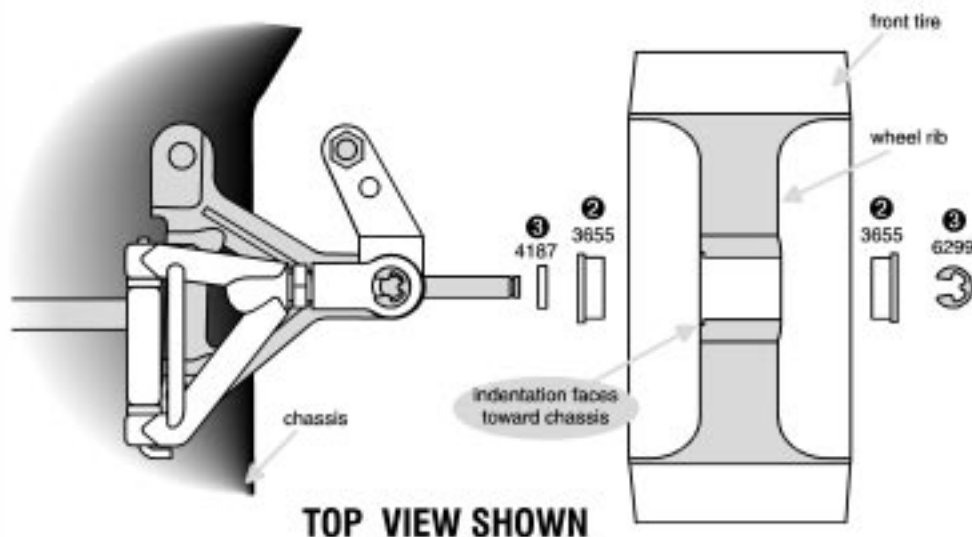

TOP VIEW SHOWN

STEP 2

DIFFERENTIAL ADJUSTMENT

1 While holding rear wheels with your hands, use your right thumb and index finger to try and rotate the spur gear. The spur gear should be very difficult to rotate. If you can rotate it easily, then tighten the #4185 11/32" nut at the end of the axle, a little at a time, until the spur gear is difficult to rotate.



BAG E

REMOVE THESE PARTS FOR:

8015: steps 1-2

8016: steps 1-2

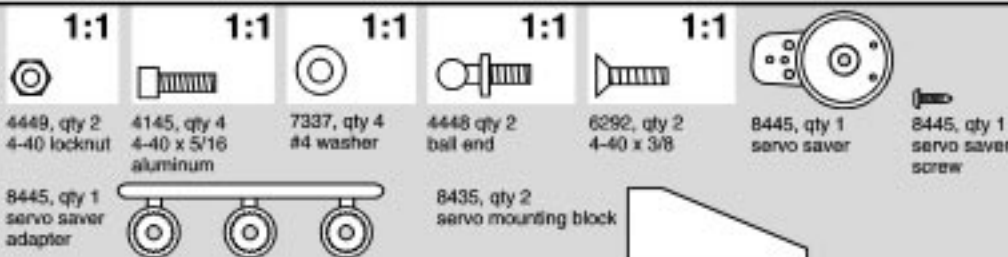

TOOLS USED

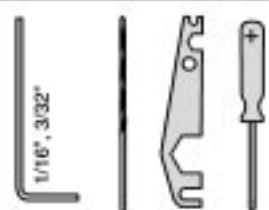

STEP 1

DRILLING STEERING SERVO BLOCKS

1 For the 1:10 scale cars we recommend you use a larger, more standard size servo. This would be a 94102 or 94737 from Airtronics; an S148 or 9101 from Futaba.

2 Drill two holes with a #43 (or 3/23") drill into the #8435 servo blocks where shown for your servo size.

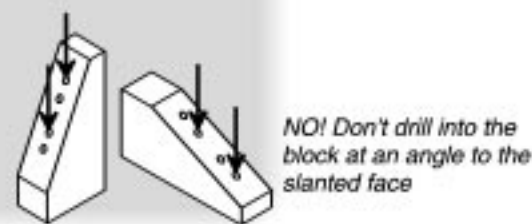
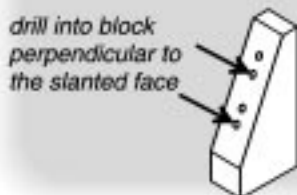

STEP 2

MOUNTING THE SERVO

1 Secure the servo to the blocks with four #4145 screws and four #7337 #4 washers.

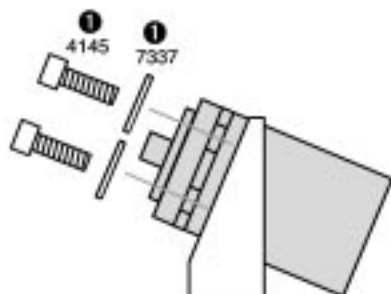

ASSEMBLING THE SERVO SAVER

2 Thread two #4448 ball ends into the front side of the #8445 servo saver. Secure the ball ends with the #4449 locknuts.

3 Try the three #8445 adaptors on the servo until you find one that fits. Push that adaptor into the servo saver.

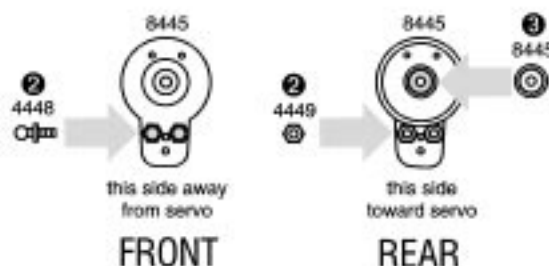

MOUNTING THE SERVO ASSEMBLY

4 Mount the servo saver to the servo with the #8445 screw. **Note:** If you have a metal gear servo, use the stock mounting screw.

5 Mount the servo mounting blocks to the chassis with two #6292 screws.

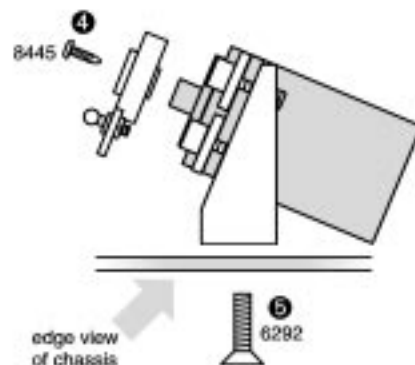

BAG E

REMOVE THESE PARTS FOR:

8015: steps 3-4

8016: steps 3-4

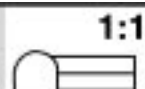

6274, qty 4
ball cup



6332, qty 4
body clip



6280, qty 4
8-32 x 1/2



4185, qty 2
8-32 locknut

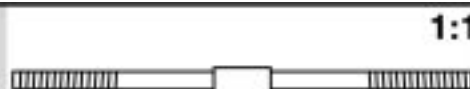

L2 KIT ONLY
8437, qty 2
steering tumbuckle



L2 KIT ONLY
8177, qty 2
front bumper



L2 KIT ONLY
4220, qty 2
front body mount



L2 KIT ONLY
6330, qty 2
front body mount

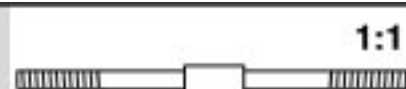

L2O KIT ONLY
8438, qty 2
tie rod



L2O KIT ONLY
8303, qty 2
front bumper



L2O KIT ONLY
8304, qty 2
front body mount

TOOLS USED

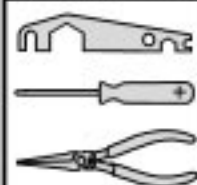

STEP 3

STEERING LINKAGE

1 Install the plastic ball cups onto the steering tumbuckles (**L2 kit:** #8437, **L2O kit:** #8438). Match the length of the tumbuckles to the actual size picture.

2 Snap one ball cup onto the ball end on the servo saver. Snap the opposite end on as shown. Install both tumbuckles.

3 When you are adjusting your tumbuckles, always make sure that the servo saver is pointing straight down.

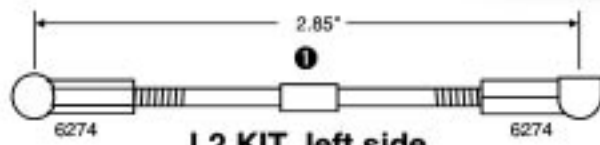

L2 KIT, left side
8437

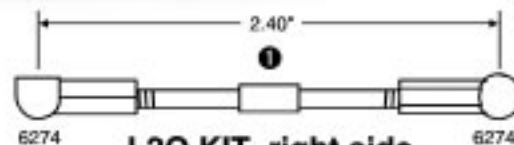

L2O KIT, right side
8438

STEP 4

FRONT BUMPER

1 Install the front bumper (**L2 kit:** #8177, **L2O kit:** #8303) and secure to the front of the chassis with two #6280 screws from underneath and two #4185 locknuts on top.

FRONT BODY MOUNT POSTS

2 Tighten the body posts (**L2 kit:** #6330, **L2O kit:** #8304) to the bumper, where the two large arrows indicate, with two #6280 screws from underneath.

3 Add #6332 body clips to the front posts and the rear.

#8015 L2 KIT

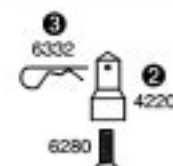
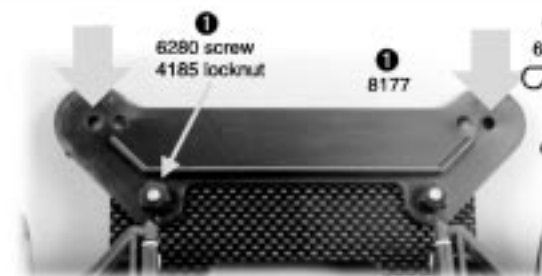

Your kit includes two body posts. Use the one that best fits the body you chose.

#8016 L2O KIT

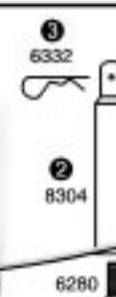
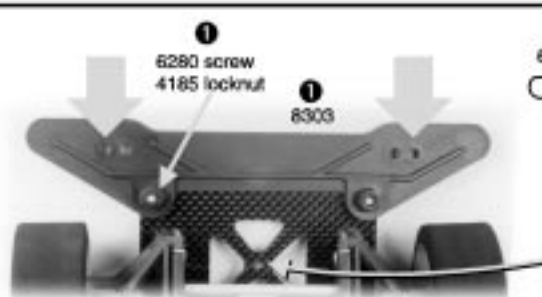

Your kit includes an extra hole for an optional body post for those bodies that require support for the hood.

BAG E

REMOVE THESE PARTS FOR:

8015: steps 5-6

8016: steps 5-6



7337, qty 2
washer



6515, qty 2
3mm x 10mm
gold



6726, qty 1
servo tape strip



4510, qty 1
roll over antenna



4510, qty 1
antenna cap

TOOLS USED

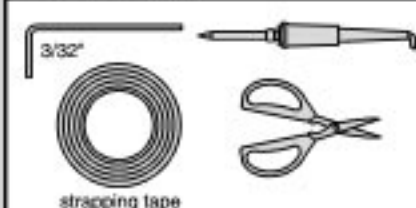

STEP 5

PINION GEAR INSTALLATION

1 Slide the pinion gear onto the shaft so that the gear is 1/16" away from the motor can. Tighten the set screw to hold it in place. Teeth side should be farthest from can.

MOTOR INSTALLATION

2 Insert the motor into the rear pod assembly as shown, the pinion gear coming through the right side motor bulkhead.
3 Tighten the motor to the bulkhead with two #6515 screws and two #7337 gold washers.
4 Set the gear mesh so that there is very little play between the spur and pinion gear. **Note:** If the gear mesh is too tight, you can lose significant power.



MOTOR AND PINION GEAR ARE NOT INCLUDED IN KIT

STEP 6

ELECTRICAL INSTALLATION

1 Solder your single cell batteries together with battery braid or battery bars. Solder plus (+) to minus (-).
2 Hold the batteries to the chassis with strapping tape. Wrap the tape over the batteries, through the chassis slot, underneath the chassis, and up again through another slot, several times.
3 Cut the #6726 servo tape to fit the bottom of the speed control and receiver. Peel the backing from the servo tape and place them where shown in the drawing.
4 Insert the #4510 roll over antenna into the antenna mount, wrap the antenna wire up the antenna, and secure the wire with the antenna cap.
5 Now connect the electronic speed control and steering servo to your receiver according to your radio or ESC instructions, then connect the motor to the ESC.

#8015 L2 KIT

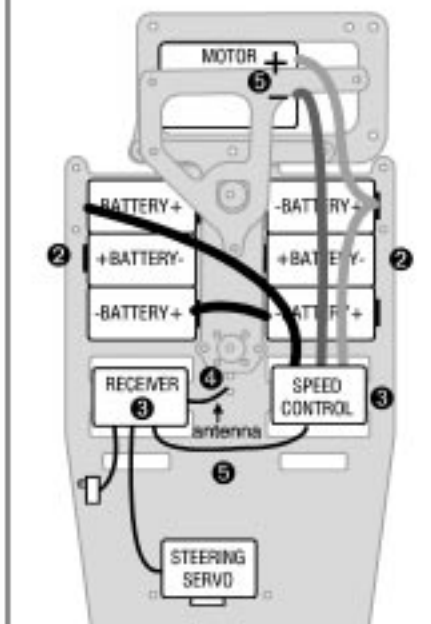

#8016 L20 KIT

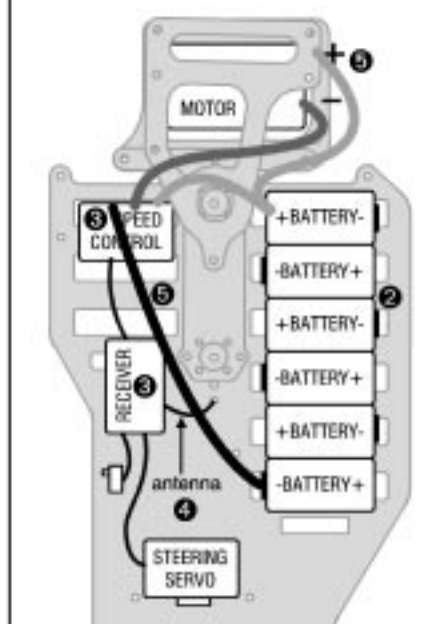

ELECTRICAL ITEMS ARE NOT INCLUDED IN KIT

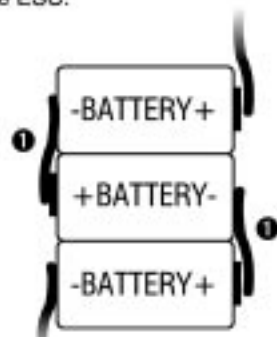

= RED WIRE
 = BLUE WIRE
 = BLACK WIRE



SETTING THE TWEAK

We set the "tweak" after EVERYTHING except the body is installed on the car, including batteries, motor, speed control, and all the radio equipment.

WHAT IS TWEAK? Ideally, the left wheel should be pushing down on the ground with exactly the same force as the right wheel. If this is not happening, the car is TWEAKED (or twisted). This can cause the car to spin out easily under acceleration. It will also cause the car to oversteer in one direction and understeer in the opposite direction.

CHECKING THE TWEAK.

1 Measure the front chassis width. Use half of this measurement to find the centerline of the chassis.

2 Scribe the centerline at the front of the chassis with your hobby knife.

3 To tweak the car, place the tip of a hobby knife on the center mark as shown.

4 Lift the front of the car slowly. We want both tires to leave the ground at the same time. If one tire leaves the ground before the other one, the car is tweaked.

CORRECTING THE TWEAK. Loosen the T-bar tweak screw 1/8 of a turn on the tire side that left the ground first. Now tighten the opposite tweak screw (the one that left the ground last) the same amount. Recheck the tweak. Continue to make these adjustments until both tires leave the ground at the EXACT SAME TIME. Always loosen one

screw first, then tighten the opposite screw the same amount.



RADIO ADJUSTMENTS

Charge the transmitter batteries if they are NiCads. (See your radio manual for instructions.) Next charge your battery pack according to the instructions included with your battery charger or battery pack. Make sure all the ESC connections are according to the appropriate manuals. Now use the following steps to make the final adjustments on your car.

1 Turn the transmitter switch ON

2 Make sure the motor is unplugged or unsoldered.

3 Plug in or solder in your battery pack.

4 Turn the car switch to the ON position. (This is normally attached to the ESC.)

5 Move the steering control on the transmitter to the right. Do the wheels steer to the right? If not, you must reverse the steering servo direction on

your transmitter (see radio manual).

6 After you have the wheels steering in the correct direction, remove your hand from the steering control on the transmitter. Now look at the servo horn mounted on the servo. Is it pointing straight down? If not, adjust its position with the steering trim control on the transmitter, or move its position on the servo.

7 Now look at your front wheels. Are they pointed straight ahead in relation to the center line of the chassis? If not, first check the alignment of the servo saver in relation to the wheels. Do they now point straight ahead? If not, use the steering tie-rod turnbuckles to adjust each wheel so that it is pointed straight ahead.

8 Adjust the ESC (electronic speed control) according to the speed control manufacturer's instruc-

tions. **Note:** Some manufacturers have the motor connected during adjustment and some do not. Now turn the car ON/OFF switch OFF.

9 Plug in or solder in your motor. Place your car on a block or car stand so that the rear wheels cannot touch anything. Turn the car switch back ON. Check the ESC operation and settings. After you have set and checked the speed control, turn the car switch OFF.

10 The transmitter switch must always be the **FIRST SWITCH TURNED ON** and **THE LAST SWITCH TURNED OFF**.

CONGRATULATIONS! YOUR CAR IS NOW READY TO RUN!

PAINTING THE BODY

1 While the body is still clear, mark and cut out the holes for the body mounts and antenna tube.

2 Clean the body and wing thoroughly before painting with warm water and a mild dish soap.

3 Mask the inside of the body according to your paint scheme, using automotive masking tape for the best results. Take the time to press down all edges of the tape. Mask off the holes you cut with tape on the outside of the body.

4 Spray the body and wing, applying the paint in thin coats and letting it dry between coats. We recommend Pactra paints.

MOTOR GEARING

To get the most from your motor proper gearing is important. The gear ratios listed in the chart below are recommended starting gear ratios. Ratios can vary from track to track but you should not change the pinion size more than one tooth from the recommended ratio.

CAUTION! Increasing the pinion size by more than one tooth can damage your motor from excess heat.

MOTOR	PINION	SPUR
24° ROAR stock motor	22	81
DS Spec motor	21	81
36° stock motor	20	81
14 turn modified motor	19	84
13 turn modified motor	18	84
12 turn modified motor	17	84

TIRE DIAMETER ADJUSTMENT

If you change tire diameter you can affect your gearing. You can calculate any gearing adjustments by using the following formulas.

Old Tire Dia.	New Tire Dia.	Factor	Old Pinion Gear	Factor	Results	New Pinion Gear
(2.1" +	1.9") =	1.105	18	X	1.105 =	19.89 = 20 (round to nearest whole number)

BATTERY CHARGING & DISCHARGING

The battery packs used for R/C cars are six-cell, sub-C, rechargeable type found in any hobby shop.

CHARGING. Proper battery charging and discharging is important to maintain the performance and life of your battery pack.

Associated recommends the use of a good quality automatic peak detection type charger. Peak detection chargers will automatically sense when the battery pack is fully charged and shut off, thus lessening the chance of damage due to over charging. Timer chargers are not recommended because a mistake can be made, thus damaging the battery pack.

DISCHARGING. To maintain performance from your battery packs, it is recommended you completely discharge them between charges. There are several inexpensive dischargers available at your hobby shop. Associated recommends the light bulb type discharger that is popular with the racers. Follow the discharging instructions supplied with your discharger for best battery performance.

MAINTENANCE

FOLLOW THESE STEPS TO KEEP YOUR CAR IN SHAPE FOR RACING

You should periodically check all the moving parts: front and rear end, suspension arms, steering blocks, steering linkage, shocks, and so on. If any of these should get dirty or bind, then your car's performance will suffer.

MOTOR MAINTENANCE

Between runs, inspect the brushes to insure they are moving freely in the brush holder. This is done by carefully removing the spring and sliding the brush in and out of the holder. If there is any resistance or rough spots, remove the brush and carefully

wipe the brush clean. This will clean off any buildup and lubricate the brush so it slides smoothly in the brush holder.

After every 3 to 5 runs, remove the brushes from the holders and inspect the tips for wear and/or burning. If there is a noticeable amount of wear, replace the brush with a new pair. If the tip is a burnt blue color, then the lubricant in the brush has been burned away and new brushes should be installed.

After every other battery charge you should carefully clean the motor. One recommended

method is to spray motor cleaner directly on the brush and commutator area. Run the motor for approximately 15 seconds. Disconnect the motor and spray it again, making sure the runoff is clear and clean. If the runoff is still dirty, repeat the spraying action until clean. After completing the cleaning, apply a small amount of lightweight oil to each bushing or bearing for lubrication. Be careful not to apply too much oil, for this will pick up dirt and contaminate the commutator and brushes.

RADIO MAINTENANCE

A radio problem is not always caused by the radio system. Often it is the result of a combination of several factors which can include: motor noise, poor electrical connections, poor wiring layout, reversed or defective receiver crystals, weak transmitter batteries, and so on. If your radio problems persist, one of the following tips may help:

1 Make sure the motor brushes are free in their

brush holders.

2 Try a different motor.

3 Try a different radio frequency.

4 Try mounting the receiver on its side with the crystal up to get it away from the chassis. Also try adding more servo tape to the bottom.

5 Try moving the receiver to a different location.

6 Bundle the radio wires well away from the servo and battery wires. Either can generate a signal into

the antenna wire.

7 The new high frequency speed controls can generate a signal which can cause interference with the receiver. Try to keep them an inch apart if possible.

Keep in mind that you can also run into outside interference. 75 MHz radio band will tend to be more susceptible to this problem than the 27 MHz band.

DIFFERENTIAL MAINTENANCE

You should rebuild the differential when the action gets somewhat "gritty" feeling. Usually cleaning the diff and applying new lube per the instructions will bring it back to new condition. Normally, as the parts seat, the diff will get smoother. If, after carefully cleaning and relubing the diff parts, the diff still feels gritty, the 1/8" balls and drive rings should be checked and possibly replaced. Refer to the diff section to correctly assemble the diff.

CLEANING YOUR CAR

You can clean your car and electronics (radio and speed control) with an electronics parts cleaner that is designated safe for plastics. They are convenient and work very well, but can be expensive. If you remove your electronics you can also clean the car and motor with motor cleaning sprays. Like the electronics cleaners, this works very well, but can cost a lot. To keep your maintenance costs down, you can clean the car (not

the motor or electronics) with normal household cleaners like 409, Fantastic, Simple Green or Associated's #711 Reedy Car Wash. These cleaners have more water in them, so to prevent rust on the metal parts you must completely dry all of these parts, or else spray them with WD40. **WARNING!** Most of these cleaners have chemicals in them that will affect the Lexan body. (Reedy Car Wash is Lexan safe.) The best way to clean your Lexan body is with warm water and a mild dish soap.

TUNING & SETUP TIPS

THESE STEPS PREPARE YOUR CAR FOR MAXIMUM PERFORMANCE

Your car is one of the most tunable on road cars on the market. This section will try to explain the parts and adjustments you can use to tune your car for different track conditions.

CASTER describes the angle of the kingpin, in relation to the vertical plane, when looked at from the side of the car. As an example, 0° of caster puts the kingpin in a vertical line. Positive caster means the kingpin leans rearward at the top. Increasing the positive caster on your car will slightly increase the steering turning into a corner and slightly decrease steering coming out of the corner. Reducing the positive caster will decrease the amount of steering you have going into a corner and increase the amount of steering you have in

the middle of the corner and exiting the same corner.

Your car has adjustable caster in increments of 2°. With the 0° upper arm mounts you can have settings of 0°, 2°, and 4° of positive caster as shown. You change the caster by placement of the PTFE caster shims on either side of the upper arm mount. The three drawings below show the loca-

tions of the caster shims and what the resulting caster settings will be. The 0° mounts are recommended for oval racing or for a less aggressive steering feel.

For greater amount of caster than moving the upper arm caster shims, you can add the #4127 caster spacers under the suspension arms. They come in 2° increments. Be aware that adding these caster shim spacers will change your ride height.

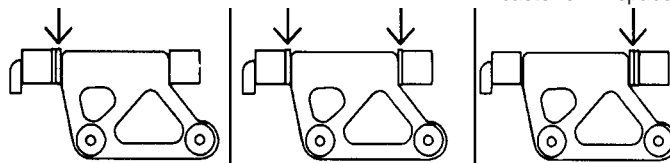

0° mount,
0° caster
2 shims forward

0° mount,
2° caster
1 shim each side

0° mount,
4° caster
2 shims to rear

REAR →

CASTER CHANGE

The 0° mount is level with the chassis when mounted. The 10° mount is angled 10° in relation to the chassis or lower suspension arm. This angle provides a change in caster during suspension movement. The caster angle will change two degrees during full suspension travel. Your car will steer more aggressively when using this option. The starting or static caster setting is changed in the same manner using the PTFE caster shims.

Static caster starts at either 2°, 4°, or 6°. A more detailed example would be a starting caster of 2° will have 0° caster at full suspension travel and a starting caster of 6° will be only 4° at full suspension travel. This setup is recommended for road racing applications, giving you the most aggressive steering possible.

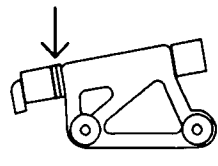

10° mount,
2°-0° caster
2 shims forward

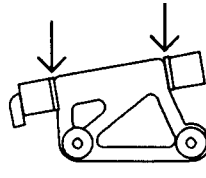

10° mount,
4°-2° caster
1 shim each side

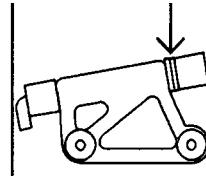

10° mount,
6°-4° caster
2 shims to rear

REAR →

CAMBER

is a word describing the angle at which the tire and wheel rides relative to the ground when looked at from the front or back. This is one of the most important adjustments on the car. Negative camber means that the tire leans inward at the top, putting it closer to the centerline of the car than the bottom of the tire. Positive camber means just the opposite, the top of the tire is further away from the centerline of the car than the bottom of the tire.

Excessive negative camber will decrease traction but increase stability. Positive camber will also decrease traction and decrease stability. A tire's maximum traction is achieved when it is straight up and down. We suggest a starting setting of 2° of negative camber. If you want to add a little more steering, reduce front camber to 1° negative or even 0°. Keep in mind that using little or 0° of camber can cause the car to be unpredictable. Try to use at least 1 to 2° negative camber at all times. This can be adjusted by turning the upper arm turnbuckles in the appropriate direction.

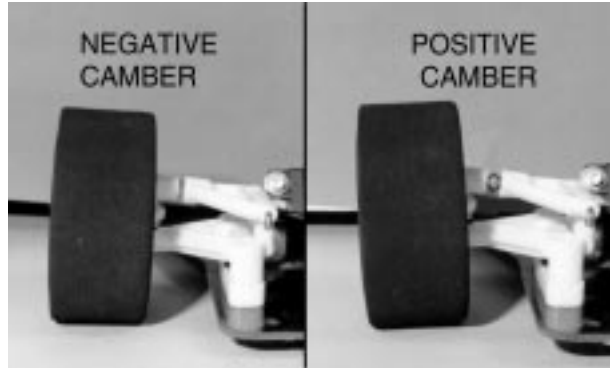

TOE-IN AND TOE-OUT

is a beneficial adjustment and has a fairly significant effect on the car. Toe-in will help stabilize your car and it also removes a small amount of turn in steering. Toe-out will allow the car to turn in to a corner quicker but will reduce stability exiting the corner. Both toe-in and toe-out will scrub speed so try to use as little, of either, as possible. You adjust the toe-in or toe-out by adjusting the length of the steering tie-rod turnbuckles.



FRONT SUSPENSION SPRINGS

are available in various wire sizes as listed below. Changing springs will increase or decrease steering. In general a softer spring (smaller wire diameter) will add steering and a harder spring (larger wire diameter) will decrease steering. Oval racing will normally require a harder spring than road course racing. The #8015 L2 kit includes #8427 springs. The #8416 L2O kit includes #8429 springs.

Part Number	Wire Size	
#8433	(.024")	Harder
#8431	(.022")	
#8429	(.020")	
#8427	(.018")	Softer

DAMPENER PLATE MAINTENANCE

It is very important to keep the dampener plates CLEAN and lubed for each race. We recommend using the Associated #6636 diff lube that came with your kit, or Green Slime from R/C Performance Specialties.

DAMPENER PLATE ROLL STOP INSERTS #4518, are included with your kit. There are two different size roll stops. Each stop will control the amount of roll that the chassis can make during hard cornering. The stop with the smallest side to side opening (in the middle) will reduce the chassis roll the most. This stop insert will make the car change directions VERY quickly during cornering. The second roll stop insert with a slightly larger opening will have slightly less of this effect. No roll stop insert (which is what we recommend for a starting setting) will be

the least aggressive for steering during hard cornering. **WARNING! You must pay very close attention to tire diameter when using either of the roll stop inserts. This is because any difference in tire diameter (side to side) may cause the dampener post to rest against the roll stop insert.** We do not recommend these inserts for oval racing.

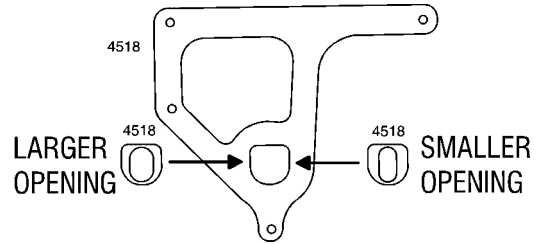

T-BAR FLEX

Look at the back end of the of the T-bar at the "T" shaped section. You will see there are three holes which can be used to attach the T-bar to the lower rear pod plate. You have assembled your car using only the two outermost holes. This setup will make the rear suspension very active (soft) front-to-rear with very little effect on the side to side stiffness. Your car will have

more rear traction and will accelerate through bumps better than if you were using all three attachment holes. Try using all three attachment holes when racing on smooth, high traction conditions.

REAR AXLE HEIGHT ADJUSTERS

Your car comes with four sets of rear axle height adjuster inserts. These inserts allow you to raise or lower the height of the back of the car without changing tire diameters. Even though there are only four offsets, three can be rotated 180° for a total of seven different axle heights as shown.

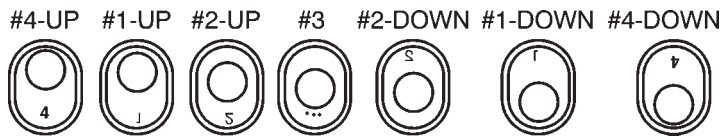

The #4-up position allows you to use the maximum diameter tire and the #4-down position requires you to use the minimum tire diameter. This adjustment allows you to get more useful life from a set of tires by adjusting axle height as tire diameter decreases. You can also adjust the overall height of your car for high or low traction conditions.

FRONT RIDE HEIGHT

To obtain your desired ride height, you can place a thick #3323 spacer under the lower suspension arm. To raise the car, take away spacers, and to lower the car add spacers.

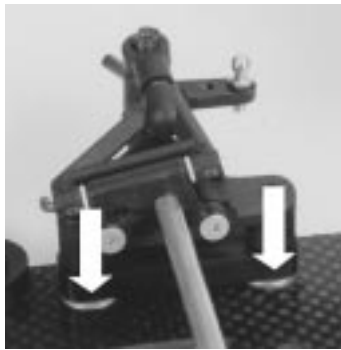

INCREASING STEERING

To increase steering, replace the stock #8421 steering blocks with the optional #8441 inline steering blocks and #8443 axles. This will make the car steer very aggressive.

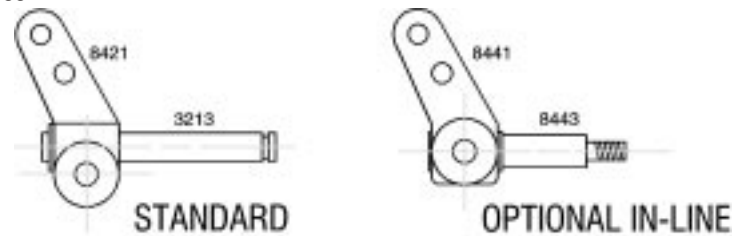

SETUP SHEET

The next page shows Team Associated's setup sheet for your car. Copy this form and keep a record of the settings you used for a particular track. This record of your settings will make it easier to set up your car the next time you race at that track, as well as compare differences between tuning adjustments. This is a feature that our Team drivers take full advantage of.

SAVE THIS BOOKLET!

More than an instruction manual, its also a handy pictorial supplement to Team Associated's RC10L catalog.

Refer to this manual for part numbers and description when ordering parts or explaining problems for customer service calls.

TEAM ASSOCIATED

3585 Cadillac Ave.
Costa Mesa, CA 92626
(714) 850-9342

SETUP SHEET

FOR THE RC10L2, RC10L20 KITS

TEAM ASSOCIATED

driver _____

track _____

date _____

FRONT SUSPENSION

NOTES _____

UPPER ARM MOUNT:



CASTER SHIM POSITION:

rear centered front other



FRONT RIDE HEIGHT SPACERS: _____

STEERING BLOCK STD INLINE

CAMBER, left _____ right _____

TOE-IN: _____° TOE-OUT: _____°

FRONT SPRINGS

SPRINGS: .018 .020 .022 .024 OTHER _____

KINGPIN STD OTHER

LABEL DRAWING FOR SHIM position, qty and thickness:

shim qty, thickness: _____

shim qty, thickness: _____

shim qty, thickness: _____

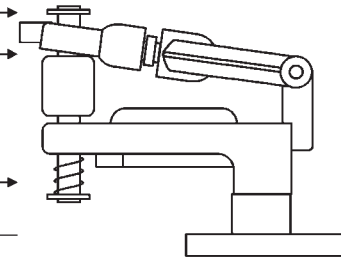

NOTES _____

REAR SUSPENSION

AXLE HEIGHT ADJUSTER:

4-up 1-up 2-up #3 2-down 1-down 4-down



T-BAR thickness: .075" OTHER _____

Dampener LUBE YES NO TYPE _____

Dampener LUBE SPRINGS STD OTHER

SHOCK

BODY STD OTHER

OIL _____ WT

SPRING _____

LIMITERS inside _____

outside _____

NOTES _____



PISTON # _____

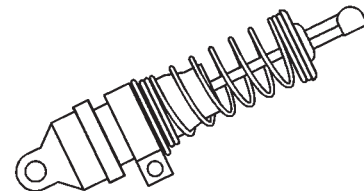

OTHER

WHEELS & TIRES	FRONT	REAR
TIRE TYPE		
TIRE DIA		
STAGGER		
CAR WIDTH		
WHEELS		

REAR AXLE STD OTHER

TIRE TREATMENT TYPE _____

SHADE IN AMOUNT OF TIRE TREATMENT:

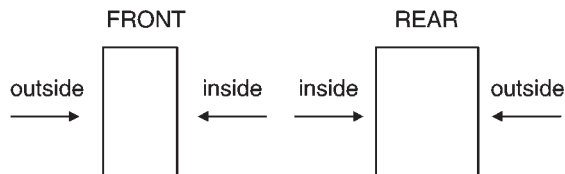

CHASSIS STD OTHER

CAR BODY _____ WING/SPOILER _____

MOTOR _____ PINION _____ SPUR GEAR _____

BATTERY TYPE _____

INDICATE BATTERY PLACEMENT:

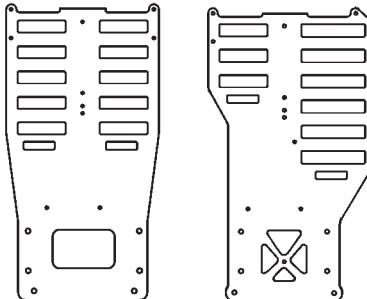

NOTES _____

GENERAL

TRACK DESC. _____

RACE COMMENTS: _____

CAR COMMENTS _____