

# ASSOCIATED R/C10

ASSEMBLY AND OPERATING INSTRUCTIONS

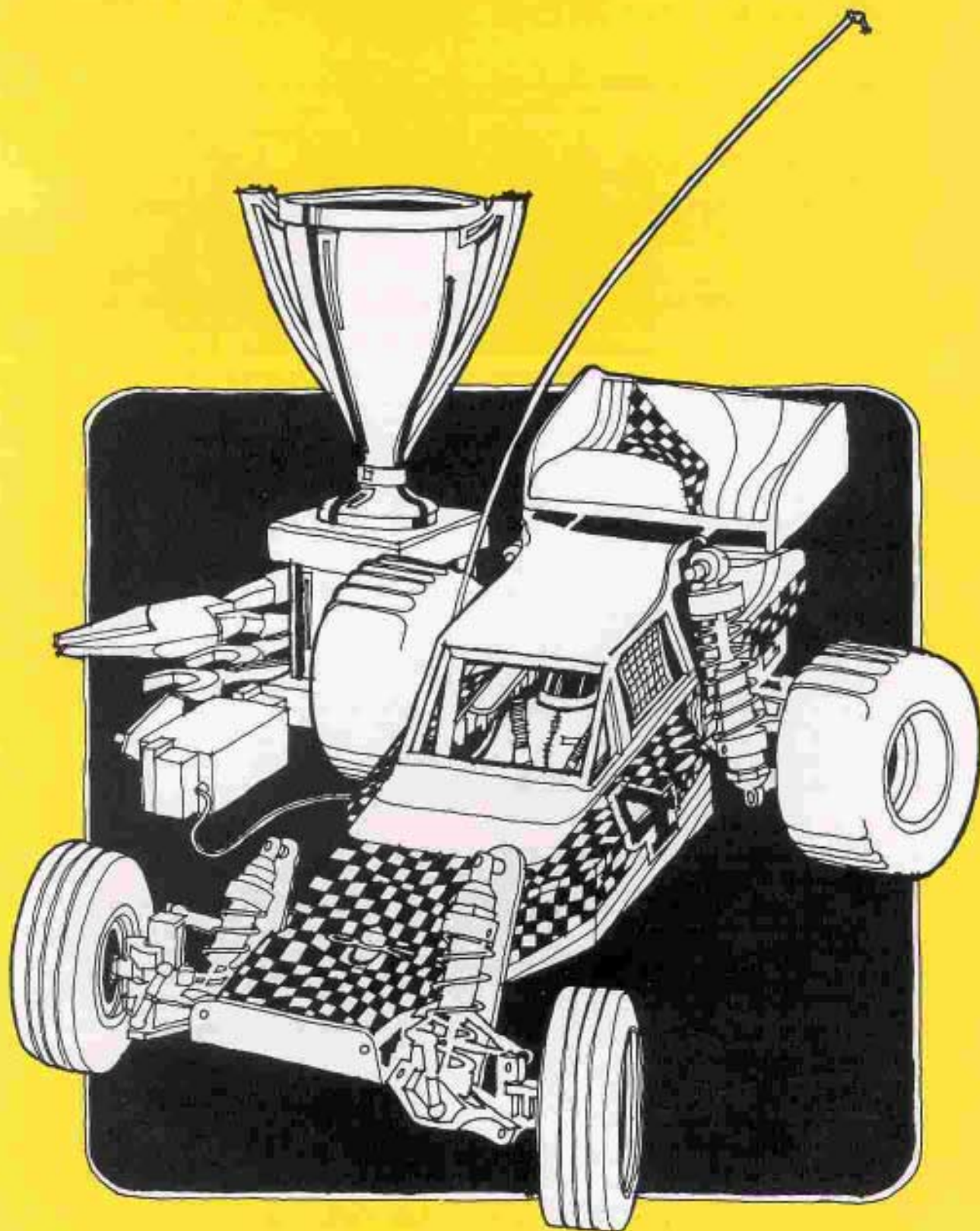

## CAUTION

Ni-cad batteries are susceptible to damage when overcharged at a high rate, and can release caustic chemicals if the overcharge is severe. Read the battery charging instructions in this manual before attempting to run your car.

Do not stall the motor under power. If the car stops suddenly on the track, or fails to move forward when you attempt to accelerate, push the throttle control on your transmitter to the brake position immediately and attend to the car. A small rock can stall the gears, and if the throttle is left in the on position the result can be a burned out motor or resistor (or electronic speed control unit).

If you run your car to the point where more than one cell in the pack is completely discharged, it is possible to lose radio control of the car before the drive motor stops completely. For this reason you should not operate your car in an area where it could be harmed or cause harm, such as near a busy roadway or a pool of water. Usually radio control will be regained as soon as you pick up the car and the motor is allowed to free-run. If you still don't have control, then you should unplug the motor.

When you stop running your car, turn off the radio at the car first (with the resistor in the off position) before turning off the transmitter.

Be sure that the resistor is in the off position while you are charging the battery.

A partially burned-out or shorted motor can make the car appear to have radio problems. If the car slows down suddenly and the radio acts erratically even with a full battery charge, then the cause is probably the motor. Check the range of the radio with the motor unplugged. A shorted motor will draw extremely high current even under no-load conditions.

### \*\*\* WARNING \*\*\*

The use of Ni-Cd packs with two-pin connectors, designed for aftermarket or for other brands of cars, can be hazardous. Some of these packs can be plugged into the three-pin connector on the RC10 in a variety of incorrect ways that can burn out your radio equipment and wire harness. All ASSOCIATED packs for the RC10 have three-pin connectors that can be inserted one way only.

# R/C 10 OFF-ROAD BUGGY

## ASSEMBLY AND OPERATING INSTRUCTIONS

Associated has used its racing experience in winning both 1/8 and 1/12 scale World Championships, to design a totally new 1/10 scale electric off road car. Our engineering and racing knowledge was used to develop a truly exceptional 1/10 off road car, that won both the ROAR and ORRCA OFF ROAD NATIONALS in 1984 and the FIRST OFF ROAD WORLD CHAMPIONSHIP in 1985.

So, we feel you have the best 1/10 scale off road car available, anywhere. You'll find the photos in the instructions are so easy to follow, that many of you may be tempted to put the car together from the photos alone. However, although you have the best car kit, if you want the best completed model race car, then you will want to put it together correctly, using these instructions. All that's required is to read the few lines of text across from each photo.

Whatever you do, DON'T OPEN UP ANY OF THE PARTS BAGS until these instructions tell you, otherwise you'll get the parts mixed up and then you will definitely be in trouble assembling your car.

While you are building the car you will sometimes be working with several parts bags at the same time. These bags are referred to by number in the instructions, and you will find a number label on each of the main parts bags. There are also more bags inside the main parts bags but these are not numbered and belong to the bag they came out of. See page 61 for the list of parts and bags in your kit.

As you can see, bags and parts will start multiplying like rabbits as you build, so try to keep things separate. One good way is to use large paper plates (picnic plates with partitions are even better). Mark the plates with bag numbers and dump the parts into them. When the parts are used up relabel the plate for another bag. It's much easier to find the part you need if it's spread out where you can see it.

**TOOLS** The kit contains all of the Allen wrenches you'll need, but you will have to supply the following tools:

- Phillips #2 screwdriver (Associated #SP76).
- Small pliers, almost any kind will do.
- A hobby knife, such as Xacto with a pointed blade.
- A soldering iron (25 to 50 watts), and a small amount of ROSIN core 60/40 solder.

Also, the kit can be assembled a lot easier if you have some of the following tools. A 3/32" straight Allen wrench with handle, will make installing the Allen screws much faster and easier (Associated #SP73). A 3/16" nut driver will make installing the ball ends easier (Associated #SP86) and a 1/4" nut driver will speed up installing the 1/4" nuts (#SP85).

**Warning!** Do not use a power screwdriver. They spin too fast causing screws to heat up when being driven into plastic, and will strip out.

Take your time assembling the car. It's not a race to see how fast you can put the car together; but rather how well you put it together, determines how fast you'll be able to race.

It would be a good idea to put a check mark at each assembly step number on these instructions after they're completed. That way, when you have to stop during assembly time, you'll be able to come back and start in the correct step.

One final note for you experienced builders and racers: please build the car **our way first!!** The RC10 is a remarkably fast car right out of the box. There's a reason for everything on the car, and very few compromises were made in its design. Work with the car first and see what it can do before you experiment or make changes.

Clear off your workbench, line up some paper plates, grab a sandwich, and let's begin ...

We'll start with **Fig. 1**. Only take the parts out of the bag that we tell you, and no others. Look for bag #64 and take the #6310 gold anodized nose piece out of the bag, as shown in the photo and the shortest Phillips flat head screw, as shown. DO NOT take anything else out of the bag. Now take the 2 Phillips screws out of bag #62, but nothing else.

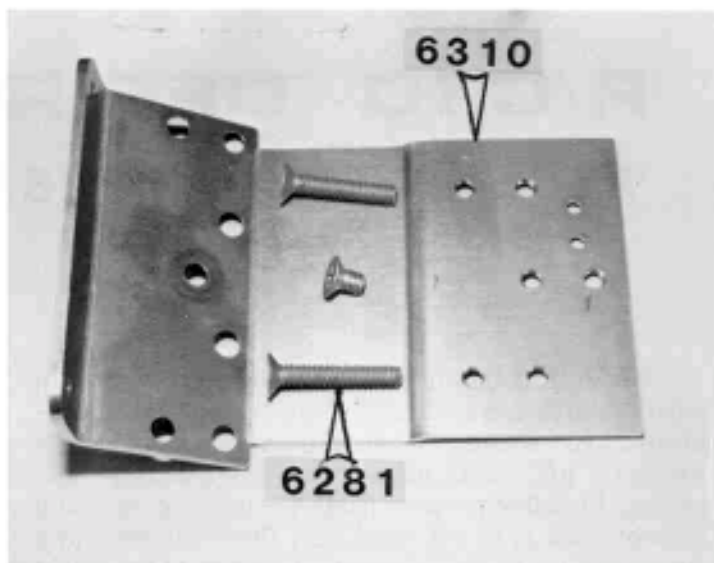

Fig. 1

**Fig. 2** Take the gold aluminum chassis #6300 and install the nose piece as shown, with the #2 Phillips screwdriver. Note that all the chassis screws are aluminum and can be easily damaged by a worn screwdriver. Be sure yours is in good condition.

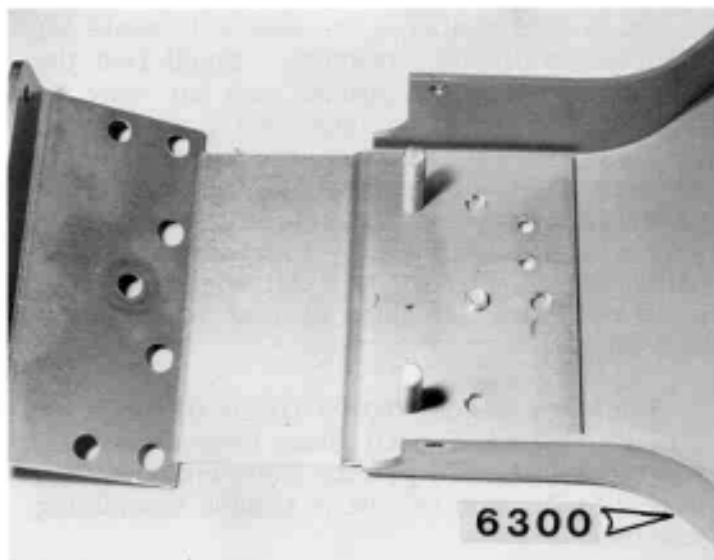

Fig. 2

-3- in bag #65, take one #6330 body mount, 2 washers and one short screw. (The long screw is used to extend the body mounts for other body styles.)

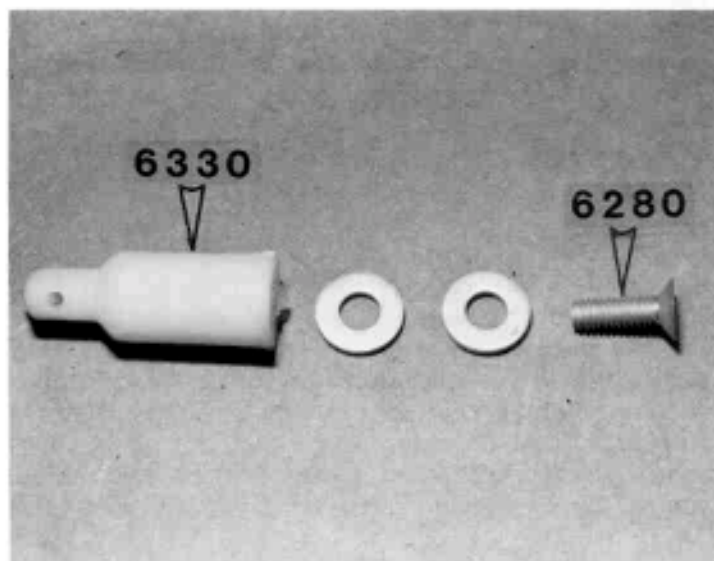

Fig. 3

-4- Install body mount as shown with body clip hole going left to right.

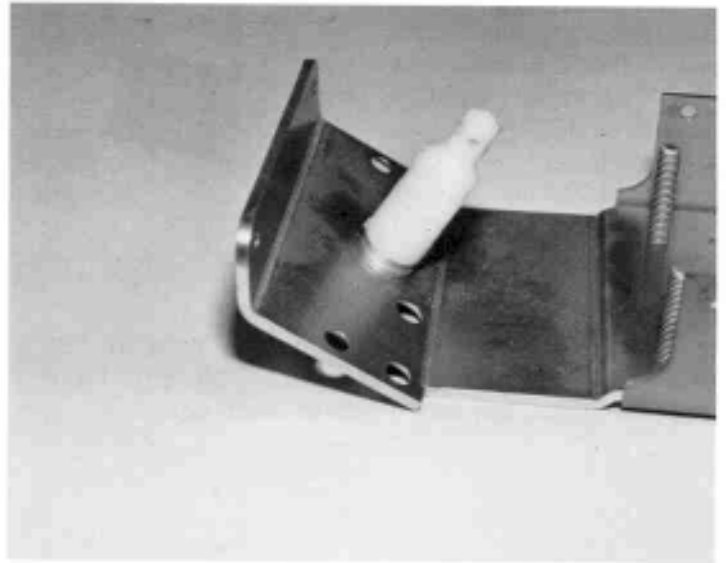

Fig. 4

-5- in bag #61, take out the left hand front suspension mount #6207. This mount will have the letter L on the bottom. The left or right hand side of the car is determined by the driver as he sits in the car. His left hand will be the left side of the car and his right hand the right side.

NOTE: The left and right front suspension mounts are attached together by a thin "runner" that must be removed with scissors or a knife.

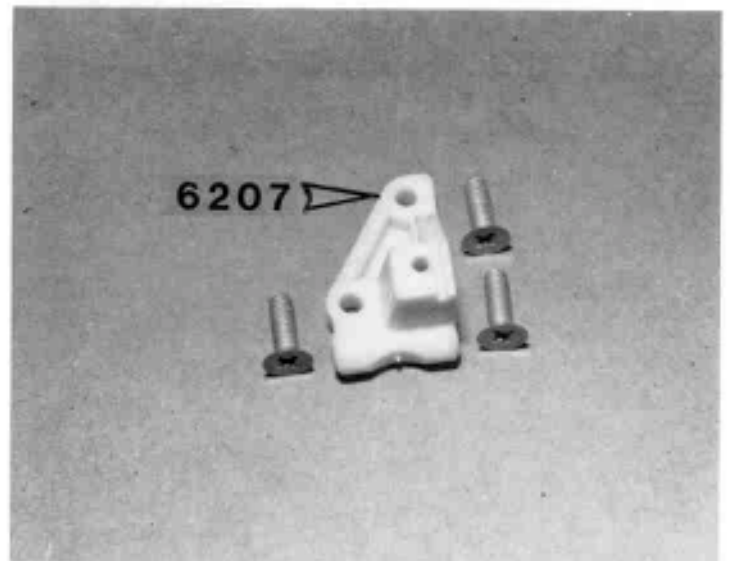

Fig. 5

-6- Install the L.H. suspension mount, as shown, with the 3 Phillips screws. Now, install the right hand mount.

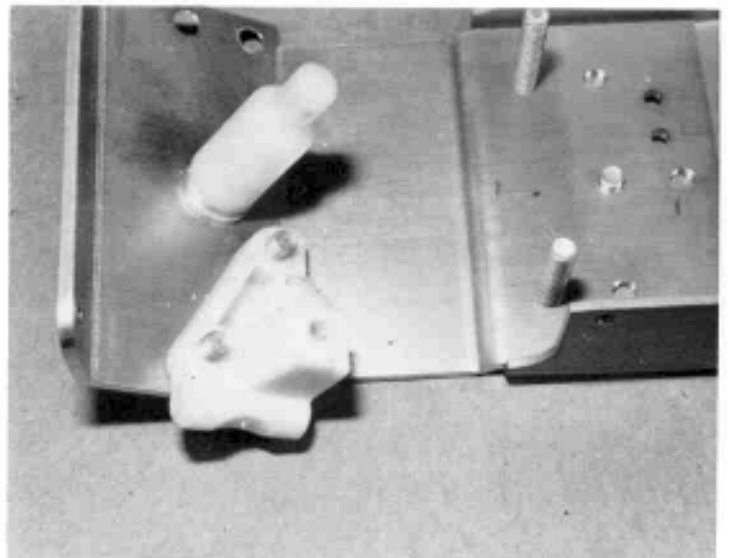

Fig. 6

-7- In the same bag, take out the #6205 L.H. front A-arm, the #6226 inner pin and the package of "E" clips, as shown.



Fig. 7a

NOTE: The package of "E" clips is in the form of a "stack" or short roll with white paper glued around the outside (see Fig. 7a). There is a role of "E" clips in three different bags. You will have more than enough to complete your car.

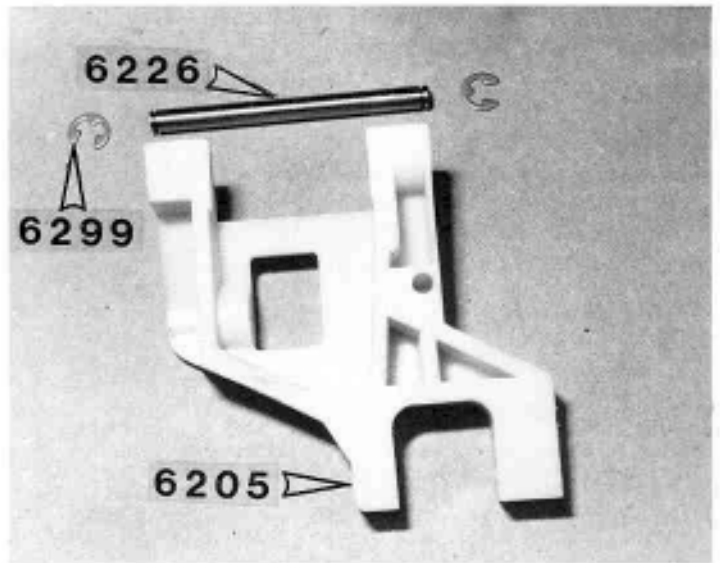

Fig. 7

-8- Line up the A arm with the mount and push the pin through. Using a small screwdriver, install an "E" clip on each end of the pin. Now, install the R.H. side.

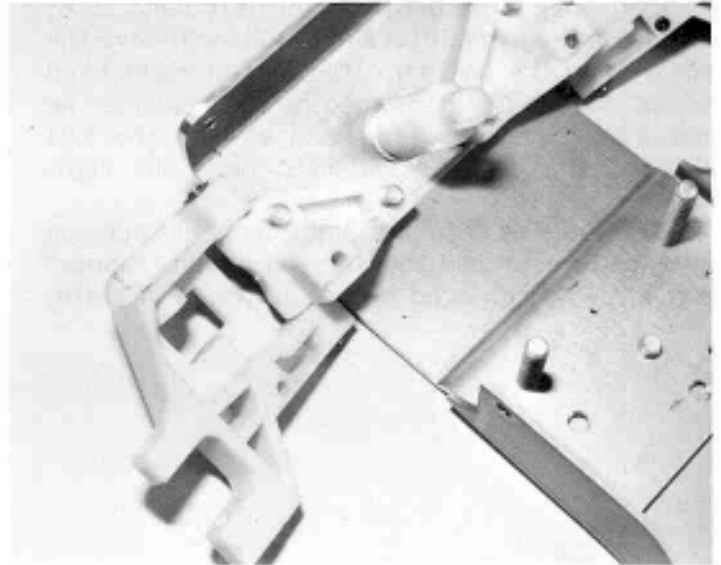

Fig. 8

-9- In the same bag, take out the #6213 front left block carrier. In bag #614 is the #6270 ball ends. Take out one of the metal ball ends only. Using the 3/16" nutdriver, or whatever tool you have, install the ball end in the block, as shown. Take the #6227 outer pin out of the bag.

NOTE: There are left and right block carriers, and they are marked "L" and "R" on the side you can't see in Fig. 9.

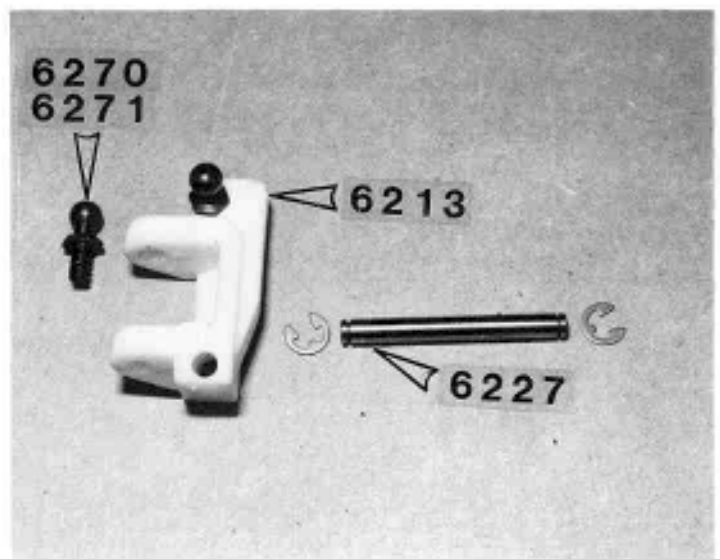

Fig. 9

-10- Line up the block carrier in the left A arm, as shown, and push the pin through. Install the 2 "E" clips. Install the R.H. block. The block carrier is intentionally tight on the pin, but the pin should swivel freely in the A arm. Do not attempt to enlarge this hole in the block carrier. If you run out of E clips there are plenty in the shock bags.

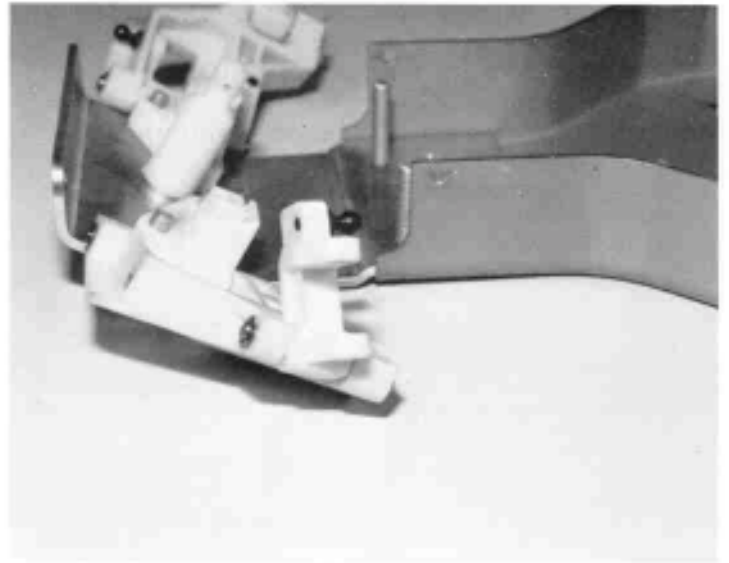

Fig. 10

-11- Take the #6219 front axle and the #6216 front steering block out of the same bag (the two steering blocks are identical and can be used on either side of the car). We want to install the axle in the steering block without damaging the plastic. If you have a vise, as shown, you can use it. If not, a piece of wood with a 3/16" hole in it will work fine. Lightly tap the axle into the block. As soon as you've got it started - STOP. Now check to see if the 6 flat spots on the axle align with the flat sides in the block. If they do not, use a pliers and rotate the axle until the flat spots are aligned. Now, lightly tap the axle all the way into the steering block. Install an "E" clip on the end of the axle. Now do the R.H. side.

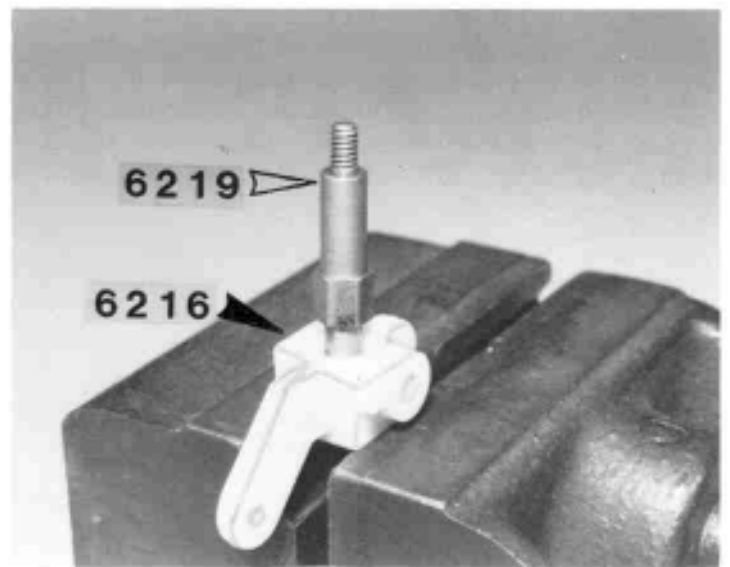

Fig. 11

-12- Install a ball end in the L.H. steering block as shown and put a plain 4/40 nut on the ball end (both from bag 614), on the bottom of the steering arm. Take the #6223 kingpin out of bag 61.

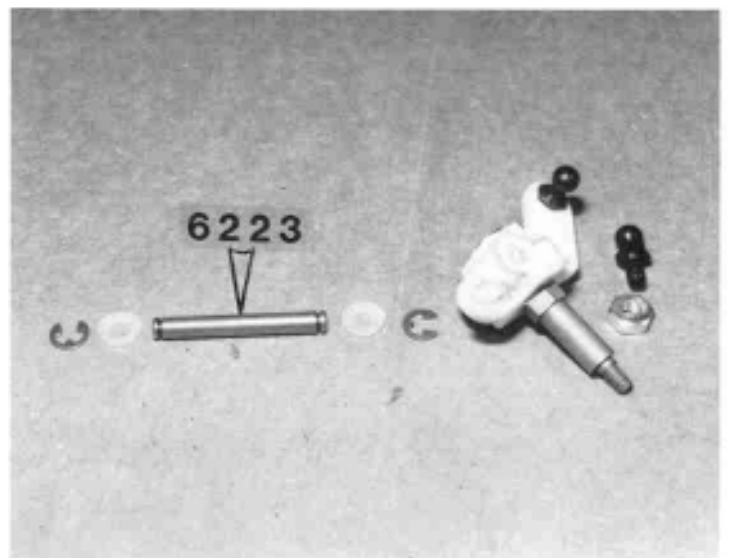

Fig. 12

-13- Line up the steering block in the block carrier, as shown, and push the king pin through. Now, install "E" clips on the top and bottom ends of the pin. If you run out of "E" clips, there are extras in the shock bags. Install the R.H. steering block.

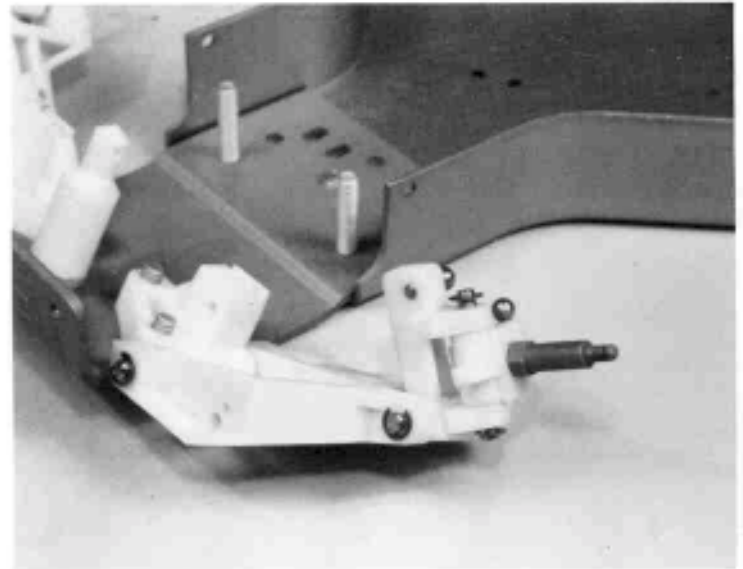

Fig. 13

-14- Take the #6230 front shock strut out of the same bag. You'll notice in the strut, there are 3 holes to mount the ball end in. Mount the ball end in the upper inside holes as shown. Put a plain 4/40 nut on the other side. Take the 2 4/40 X 1/2" Allen bolts out of the bag, as shown.

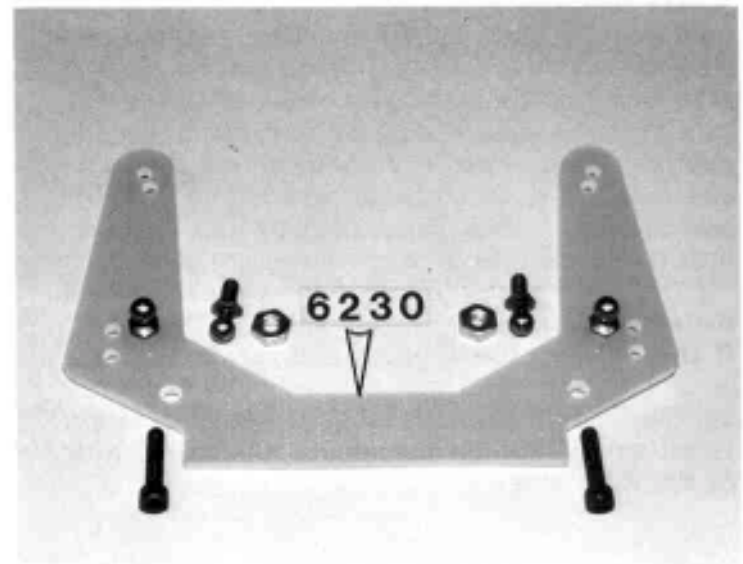

Fig. 14

-15- Install the shock strut onto the front suspension mounts with the 2 4/40 bolts as shown.

NOTE: If you have difficulty lining up the holes you can temporarily loosen the screws holding the mounts to the chassis, and then retighten them after the strut is installed.

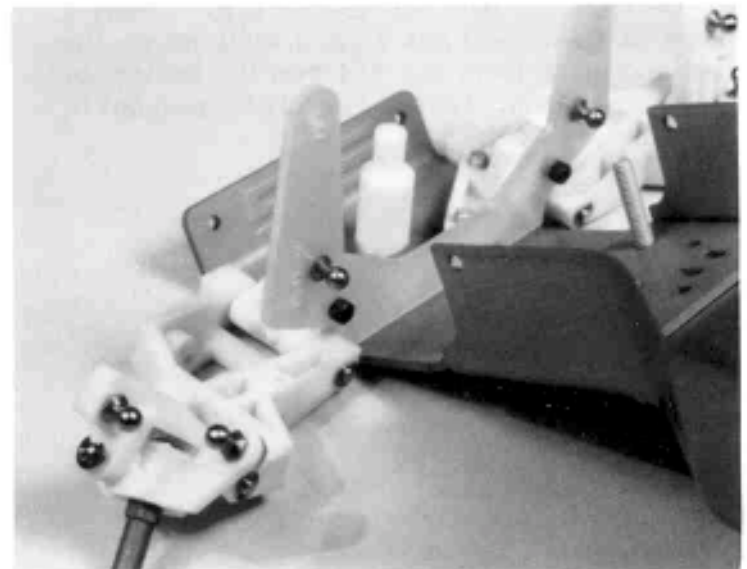

Fig. 15



-16- In the same bag, take out the 2 threaded 4/40 rods. In bag #614 take out the plastic ball rod ends as shown. Twist the rod ends, and take 4 of them off.

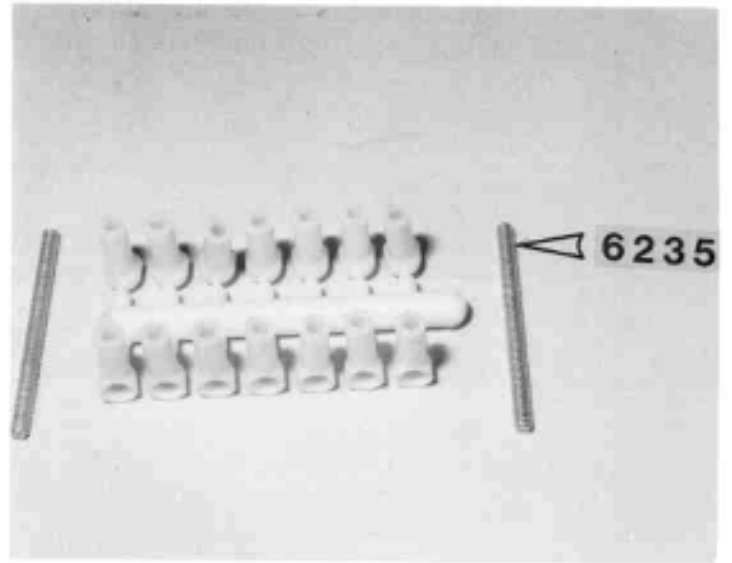

Fig. 16

-17- Screw the plastic ball rod ends onto the rods as shown. You'll be able to start them by hand, but you'll need 2 pliers to screw them down. Be careful not to damage the ends. We want to screw the rod ends on so they are 1.475" or 37.47 mm long. This is measured from the center of the ball, as shown. You'll notice a center line on the plastic ball.

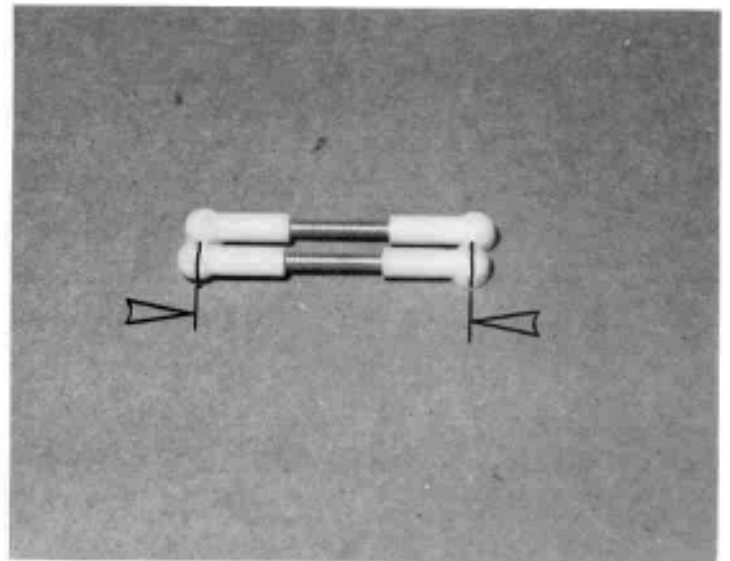

Fig. 17

-18- Snap the rods on the metal balls, as shown. You'll probably have to use pliers. Do the R.H. side.

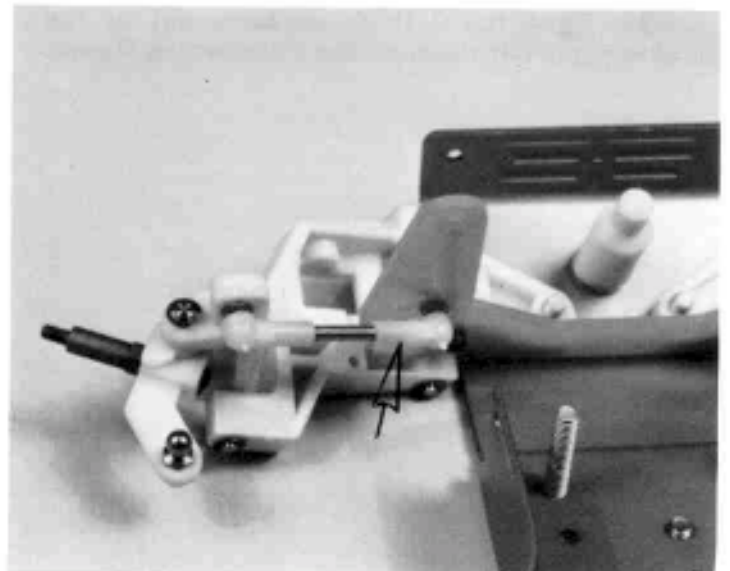

Fig. 18

-19- In bag #62, take the #6255 servo saver parts out, and install the 4 ball ends, as shown.

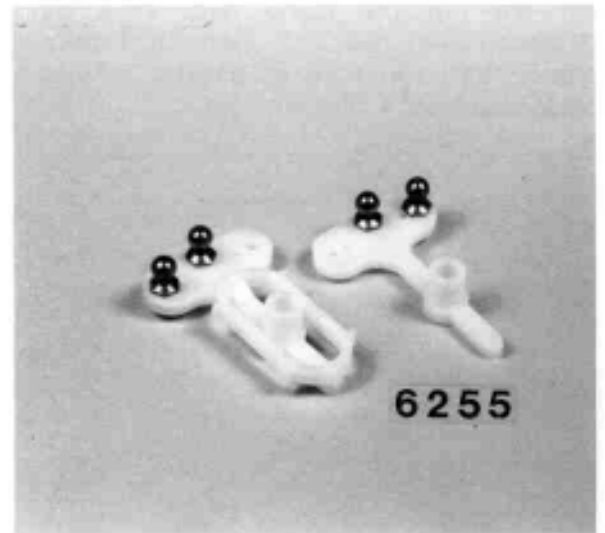

Fig. 19

-20- Locate the servo saver arm. . .

-21- and install it to the servo saver, as shown.



Fig. 20

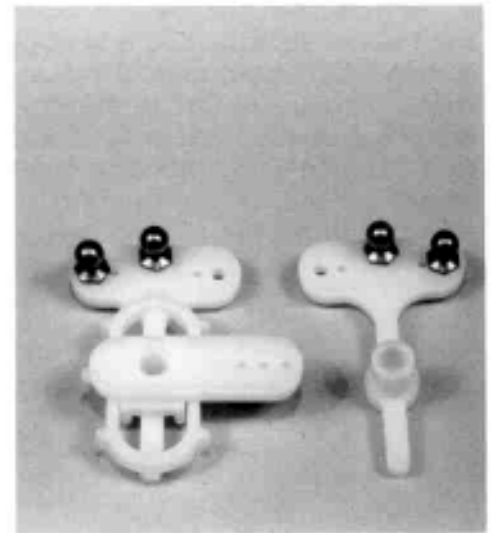

Fig. 21

-22- Take the 2 thick washers, out of the same bag, and put them on the 2 screws, as shown.

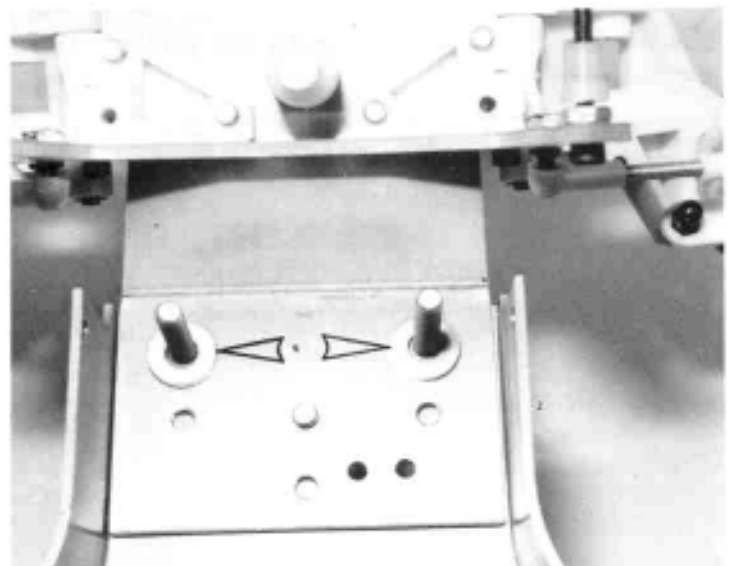

Fig. 22

-23- Place the servo saver parts on the 2 screws, as shown. Take the 2 nylon nuts and screw them down until the servo saver starts to bind, and then back the nuts off about 1/2 turn until the servo saver arms pivot freely.

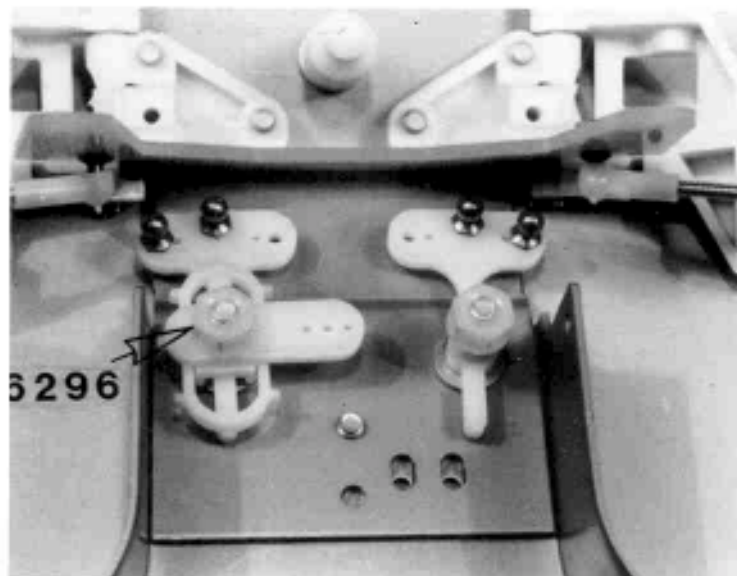

Fig. 23

-24- Take the 2 long and 1 short threaded rods out of the bag. Make the long rods 2.025" or 51.44 mm long, and the short rod 1.500" or 38.10 mm long. These are measured at the center of the ball.

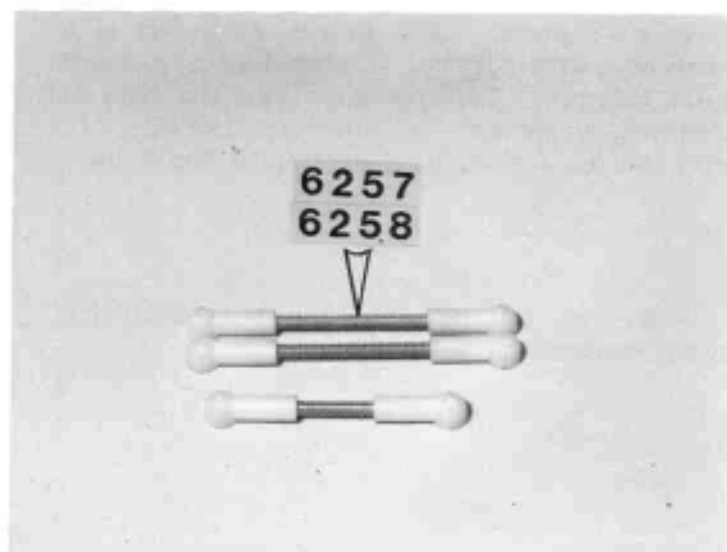

Fig. 24

-25- Snap the short rod on the servo savers, as shown.

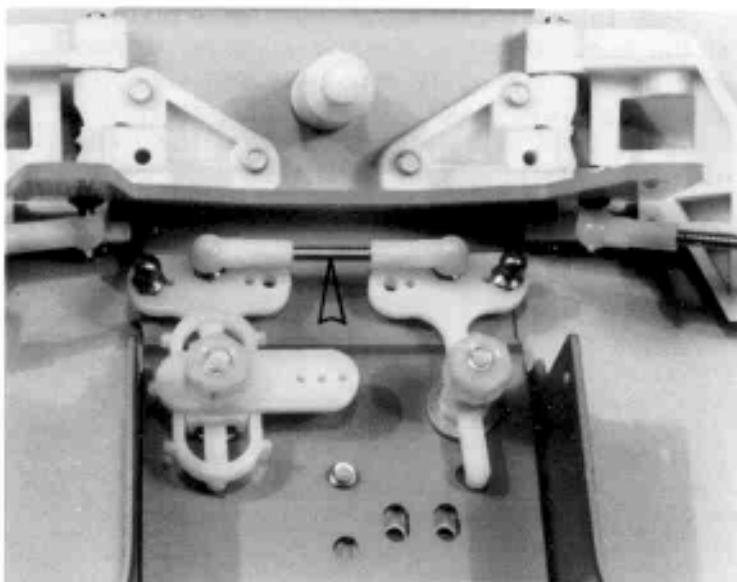

Fig. 25

-26- Snap the L.H. and R.H. tie rods on, as shown.

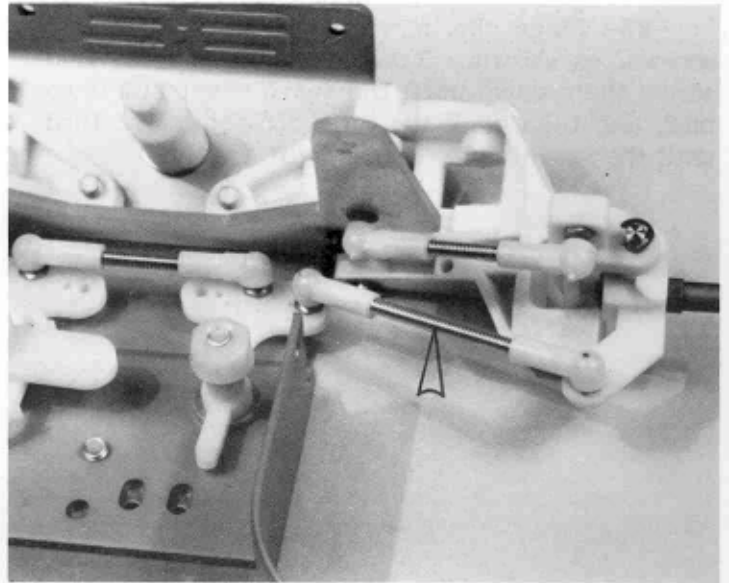

Fig. 26

-27- In the #612 bag, take out the #6609 drive gear pivot. Also in the #612 bag is a small bag with screws. In this bag is a small split roll pin. This pin goes into the hole in the pivot, as shown. Use a needle nose pliers to hold the pin and lightly tap it into the hole.

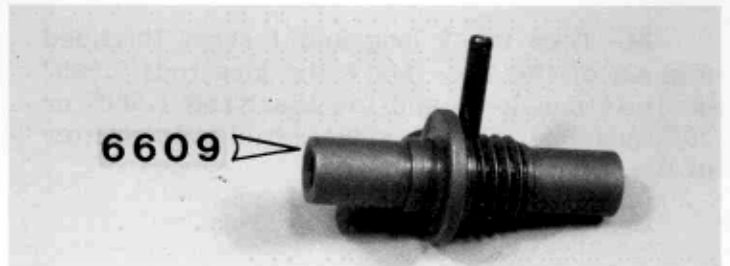

Fig. 27

-28- Tap the pin into the hole until it's evenly centered on both sides.



Fig. 28

-29- Take the #6611 aluminum spine plate out of the bag. Using a vise, or a piece of wood with a 1/4" hole in it, carefully tap the pivot into the plate. Make sure the pin is centered with the slots in the plate, and that the flange of pivot is flush against the surface of the plate.

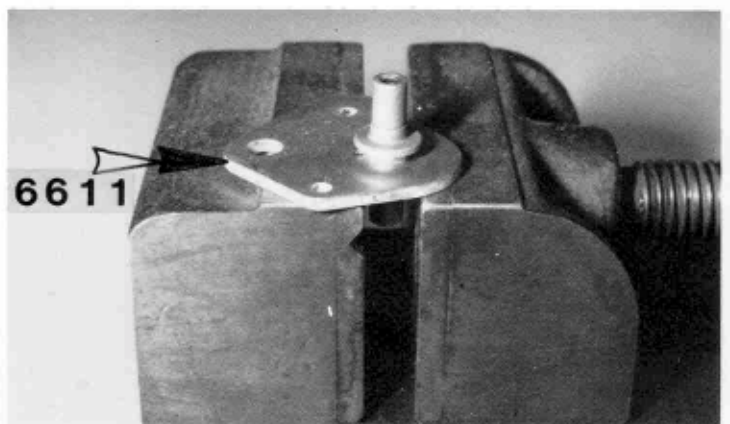

Fig. 29

-30- Take the large thin 1/4-28 hex nut out of the bag. Turn the plate over and install the nut. Tighten the nut with a socket or open-end wrench while holding the spine plate. You may want to put a drop of thread-locking compound on the threads to make sure the nut doesn't come loose.

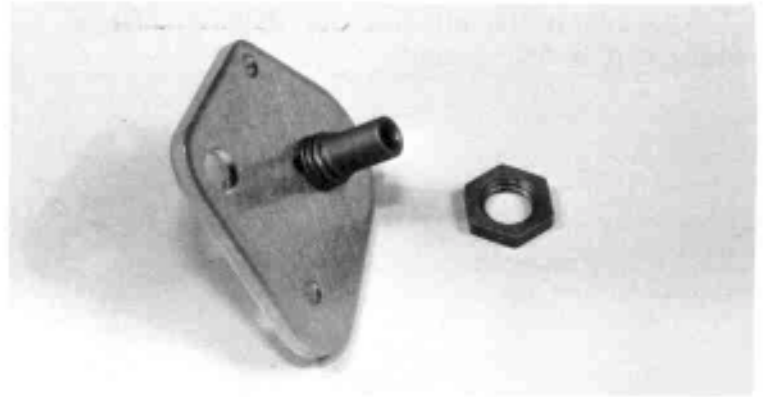

Fig. 30

-31- The pivot should look like this installed.

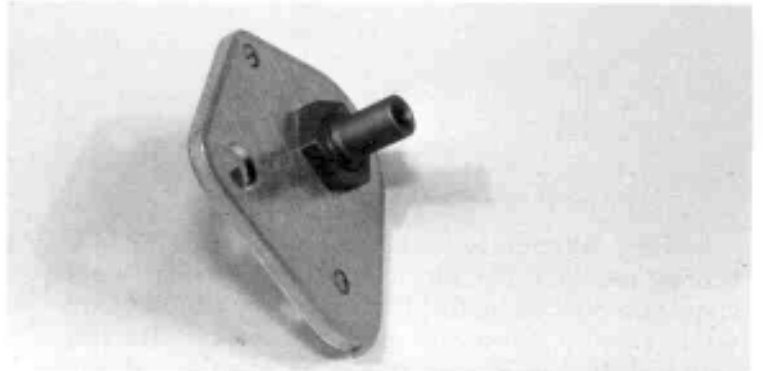

Fig. 31

-32- Take the #6610 idle gear pivot and gently tap it all the way into the aluminum plate, again making sure that the flange touches all the way around.

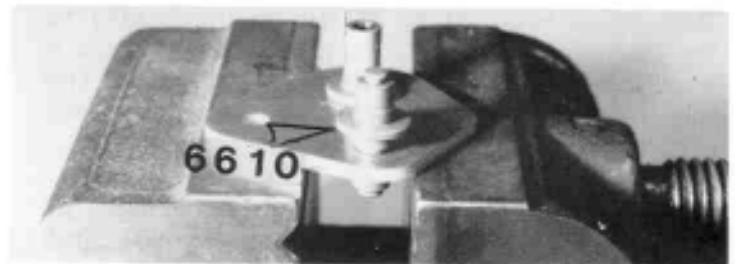

Fig. 32

-33- Turn the plate over and take the flat steel washer and slip it over the pivot as shown by the arrow.



Fig. 33

-34- Install the large curved "E" clip, as shown, with the center up, and the ends down.



Fig. 34

-35- Install the clip all the way on. Make sure the it is fully seated.

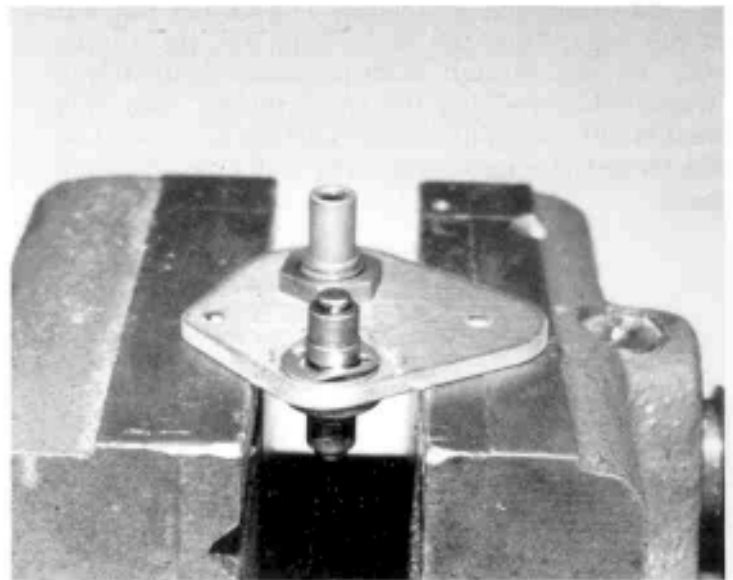

-36- Associated makes a complete ball bearing package for the RC10, part #6900. We'll show you how to install the bushings, which come with the kit, and the ball bearings. They're both installed in almost the same manner. If you are using bushings then wipe off the bushings and install them into the 2 #6612 axle drive gears. They are a snug fit so it will be necessary to tap them in with a soft blunt object such as a wood dowel. Make sure they are seated all the way in so that the snap ring groove in the gear is exposed.

-37- If you have the ball bearing kit, install the small unflanged bearing #6901 first and then the #6902 flanged bearing.

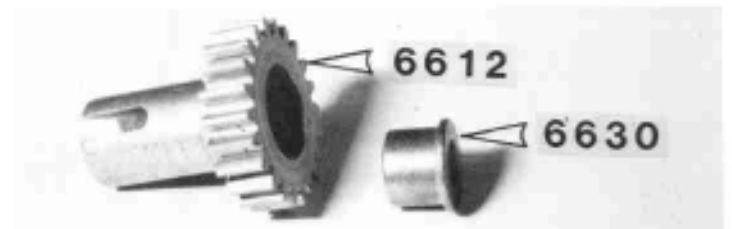

Fig. 36

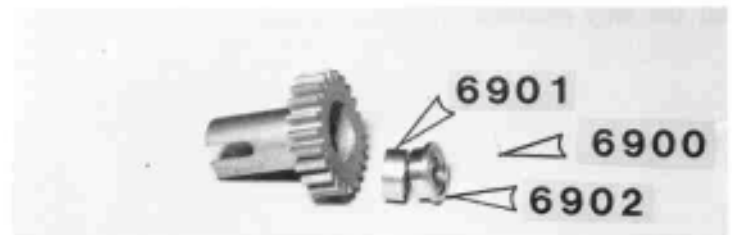

Fig. 37

-38- Install the inside "C" clip.

-39- Make sure the clip seats all the way.



Fig. 38

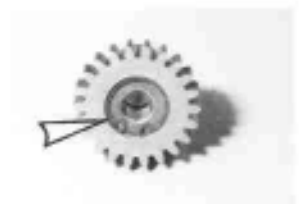

Fig. 39

-40- If you've installed ball bearings, now install the "C" clip.

-41- The installed clip should look like this.



Fig. 40



Fig. 41

-42- Now take the aluminum plate, and put a little oil on the bushing in one of the #6612 gears and install it onto the #6609 pivot, using one of the button head screws, as shown.



Fig. 42

-43- Turn the plate over and oil and install the other gear.

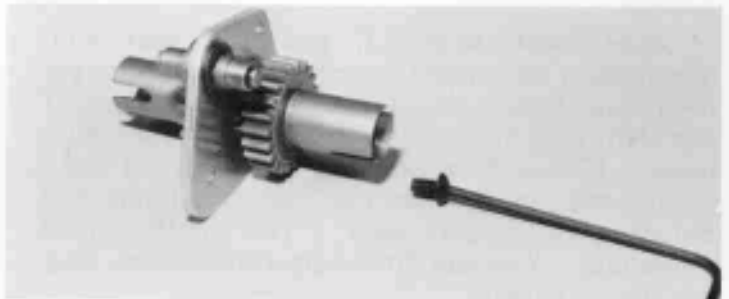

Fig. 43

-44- Take the 2 #6613 plastic gears out, and 2 of the short small bushings.

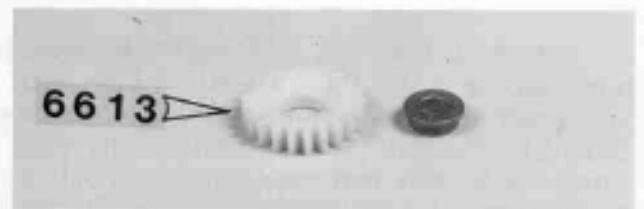

Fig. 44

-45- Install the bushings in the gears and then install the 4 small button head screws as shown. Only tighten the screws until they seat. Do not overtighten. Be careful because the screws are very small. If the wrench starts to slip it can be sharpened by cutting a small amount off the end with an abrasive cut-off wheel or grind stone.

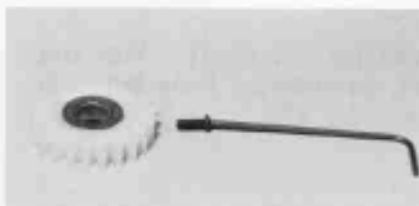

Fig. 45



Fig. 46

-46- The completed gear.

-47- The ball bearing installs the same way.

-48- Install the screws in the gear.

-49- Completed gear with ball bearing.



Fig. 47

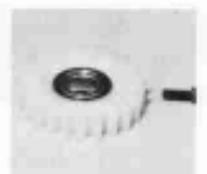

Fig. 48

-50- To lock the screws in, we recommend the use of pink ZAP. This is a cyanoacrylate adhesive. Put a VERY, VERY SMALL amount of ZAP on the end of an Xacto blade and put it on the bottom screw as shown. Now rotate the gear and put it on the 2nd screw, which will now be in the bottom position. This way if you get too much ZAP on, it will run down away from the bearing and not on the bearing. Do all 4 screws this way, on both gears.



Fig. 49



Fig. 50

-51- Now oil the bushing and put the completed gear on the pivot pin on the aluminum spine plate.

-52- Oil and put the 2nd gear on and install both "E" clips.

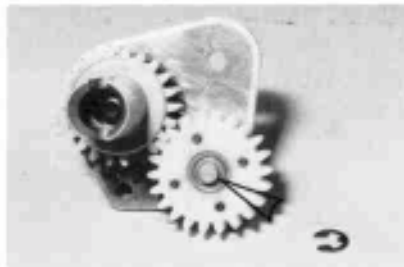

Fig. 51



Fig. 52

-53- Rotate both L.H. and R.H. gear sets. They should both rotate very freely. If they do not rotate freely, you probably don't have one of the pivot pins installed properly in the aluminum plate. (Those flanges **must** be flush and even against the plate!) You can also try lifting and rotating the plastic gear a few teeth before remeshing. You can find a position where they are the smoothest.



Fig. 53

-54- Now take the #6618 differential shaft with gear, and the thick thrust washer with the small hole from the same small bag. The gear is locked to the shaft on a taper. If the gear has come loose you can reseal by supporting the gear on the top of a vise and giving the big end of shaft a sharp rap with the WOODEN handle of a hammer.



Fig. 54

-55- Slip the washer on the shaft. Slip the blue thrust bearing on, as shown. Now set this shaft aside until we do step #67.



Fig. 55

-56- Take one of the #6606 bearing adaptors out of bag #612 and one of the narrow bushings with a 1/4" dia bore.

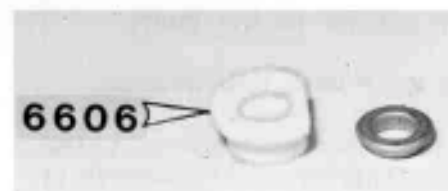

Fig. 56



Fig. 57

-58- If you're installing ball bearings, install it in the adaptor.

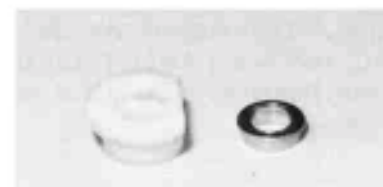

Fig. 58



-59- Take the #6617 dif tube out of the bag.

-60- Oil the bushing and slip it on the dif tube, as shown.

-61- Take the #6621 dif pinion gear out of the bag.

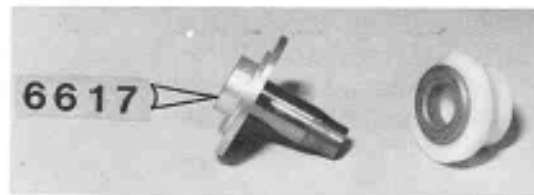

Fig. 59



Fig. 60

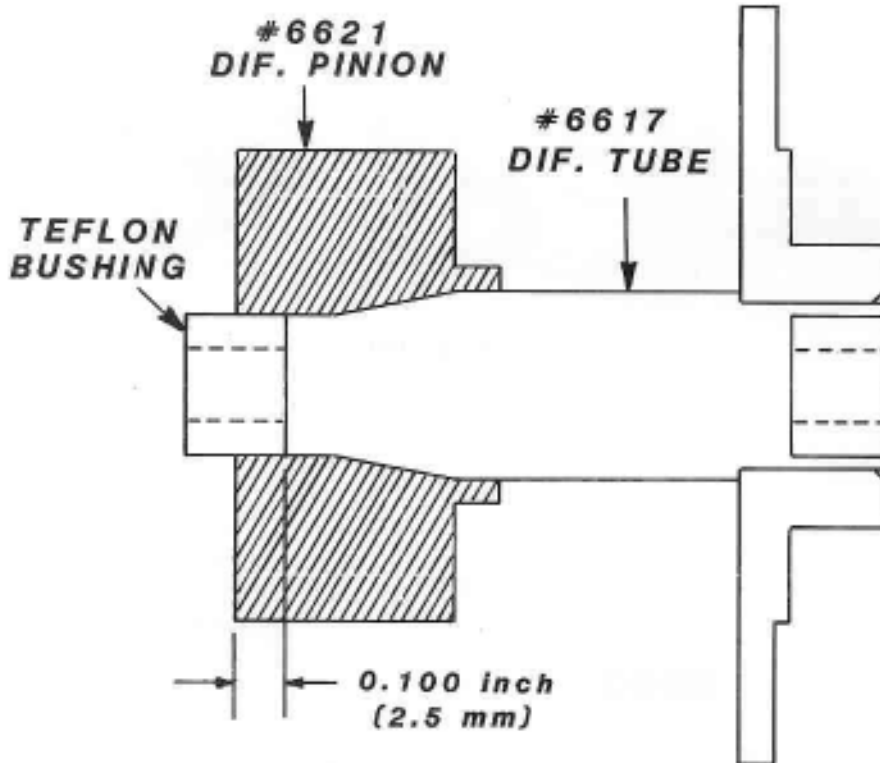

Fig. 62

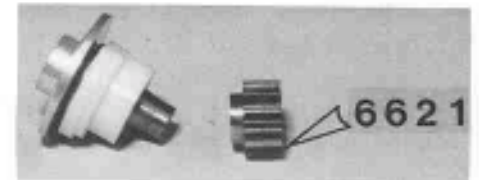

Fig. 61

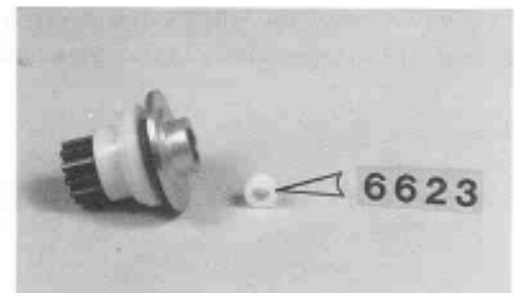

Fig. 63

-62- Slip the gear onto the tube and tap the assembly together using the plastic handle of a screw driver. DO NOT use a vise to squeeze it on. The gear does NOT go all the way on. There should be enough room left in the gear (.100 or 2.5 mm) to install the Teflon bushing shown in Fig. 65.

-63- Take one of the #6623 small white Teflon bushings out.

-64- You should be able to push the bushing into the tube with your finger.

-65- Now take the other #6623 bushing and the other thick thrust washer out. Push the bushing inside the washer.

-66- Push the bushing into the dif tube, as shown.

-67- Now slip the dif tube assembly onto the dif shaft, as shown.



Fig. 64

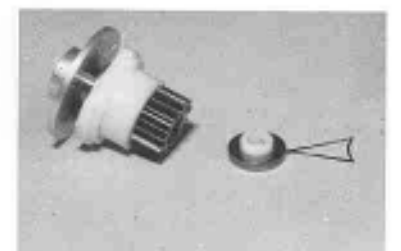

Fig. 65



Fig. 66

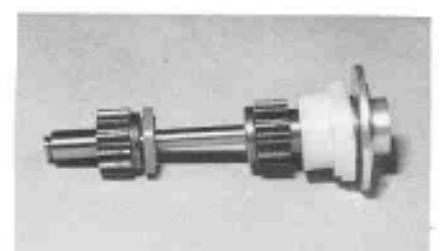

Fig. 67

-68- The dif tube assembly should spin freely on the dif shaft. If not, the Teflon bushings might not be centered correctly. Check this, and use the shaft to help center the bushings.

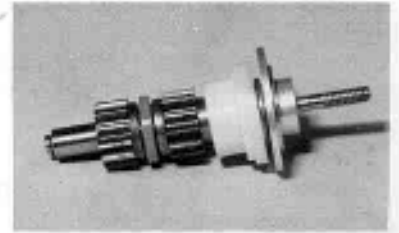

Fig. 68

-69- Take one of the #6625 dif drive rings out of the bag.



Fig. 69

-70- Slip the ring on the hub, as shown.

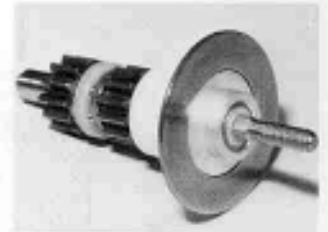

Fig. 70

-71- Take the #6626 balls out of the bag. In bag #615, take the plastic spur gear.

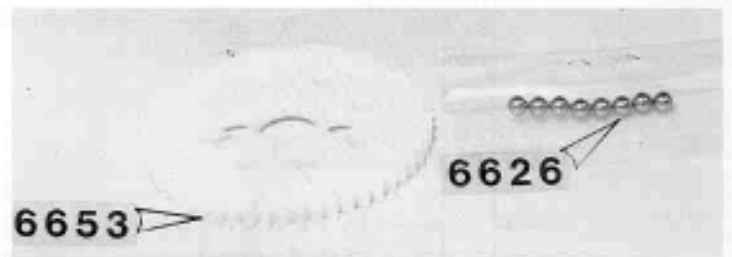

Fig. 71

-72- Push the 8 balls into the square holes in the gear as shown.

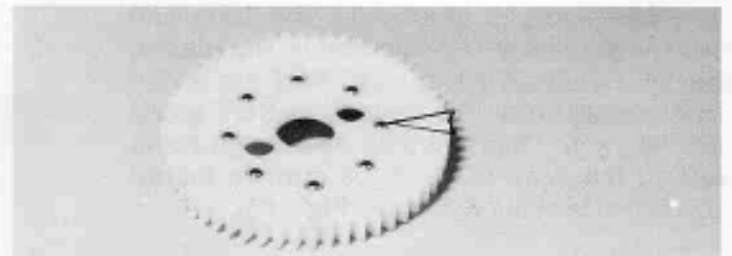

Fig. 72

-73- Take the #6036 Associated dif grease.



Fig. 73

**-74-** Apply a small amount of this special grease to the balls on both sides of the gear. NEVER use any other type of grease on the balls, otherwise the dif will slip.

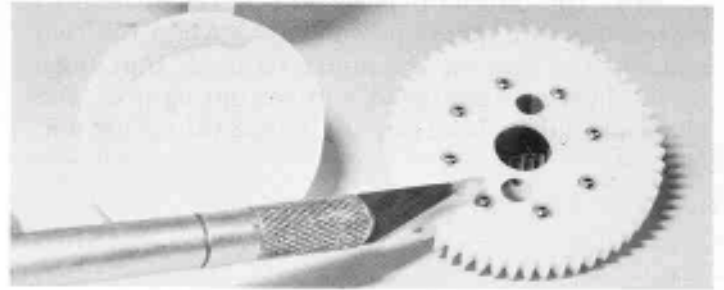

**Fig. 74**

**-75-** Apply a small amount of the #6636 Associated dif grease to the center hole of the gear. DO NOT use this dif grease anywhere else on the car for metal to metal lubrication. (It's intended as a plastic to metal or plastic to plastic lubricant.)

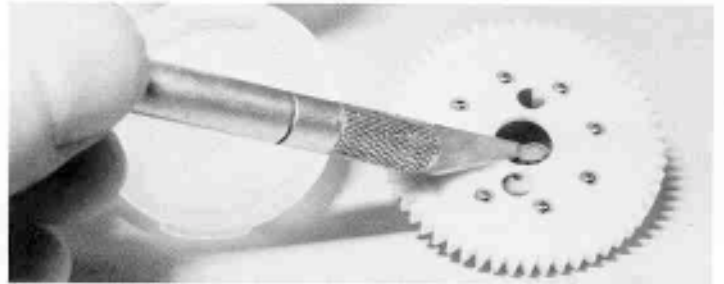

**Fig. 75**

**-76-** Take the dif shaft assembly and spur gear.

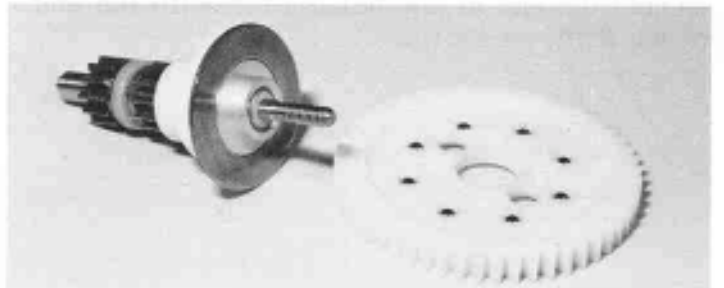

**Fig. 76**

**-77-** Slip the spur gear on the shaft. Take the other drive ring.

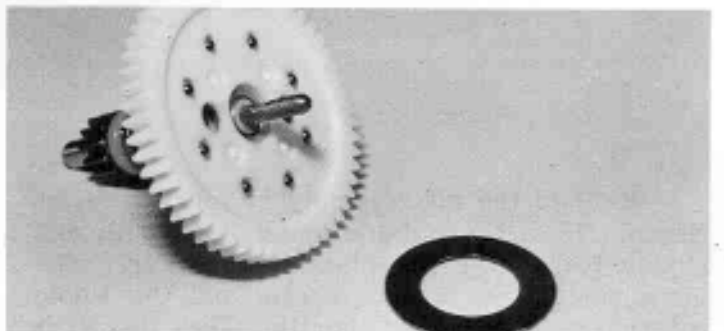

**Fig. 77**

**-78-** Slip the drive ring on the shaft and take the #6624 dif outer hub.

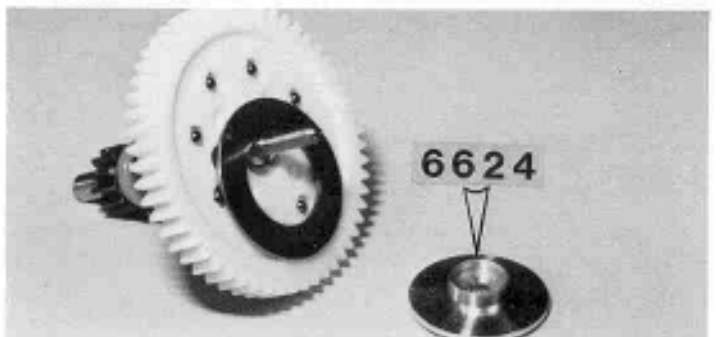

**Fig. 78**

-79- The outer dif hub has a notched hole to match the flat spots on the shaft. Align the two and slip the hub on the shaft. Check that both drive rings are centered and seated against the aluminum hubs. Take out the #6628 dif spring and nut.

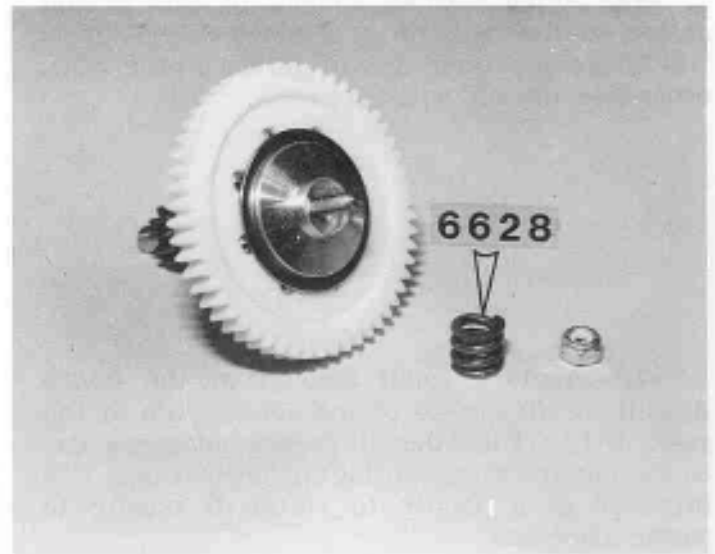

Fig. 79

-80- Slip the spring on and screw the nut on. You'll have to hold the small gears from turning while screwing the nut on. Screw the nut on until the end of the nut is even with the end of the shaft, as shown.

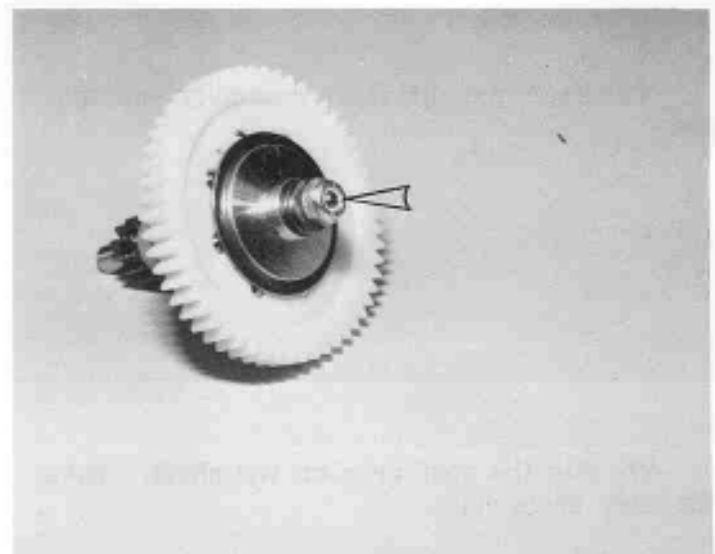

Fig. 80

-81- Hold the dif assembly in your hands, as shown. Hold the outside small gear still, and slowly rotate the big plastic spur gear. The inside small gear should rotate, and the whole rotation should be very smooth. Then the dif is working correctly. Now hold both small gears tightly in your fingers, and try to turn the big plastic gear. It should be VERY HARD to turn.

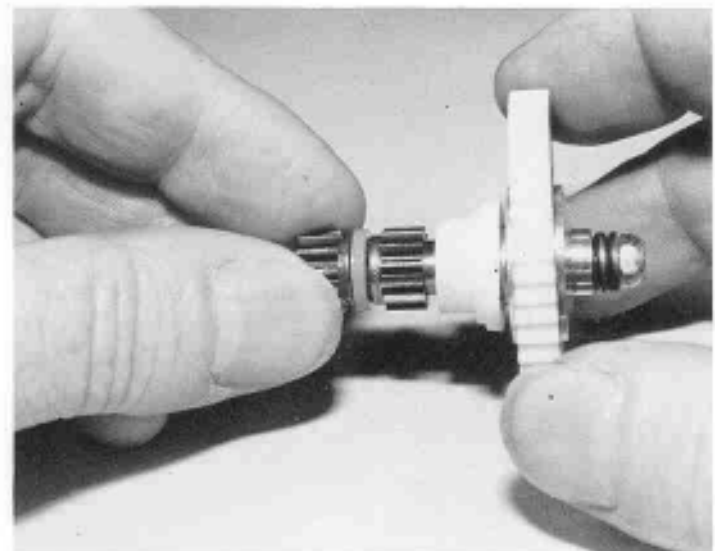

Fig. 81

-82- Take the #6607 motor mount out.

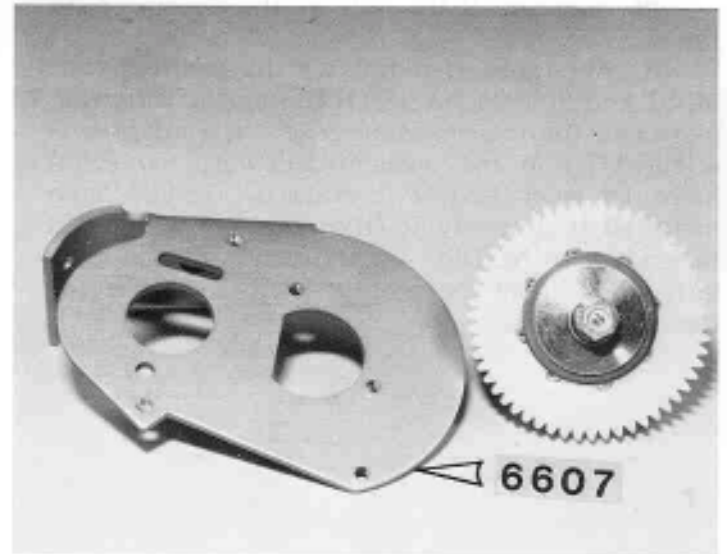

Fig. 82

-83- Slip the dif into the motor mount, as shown.

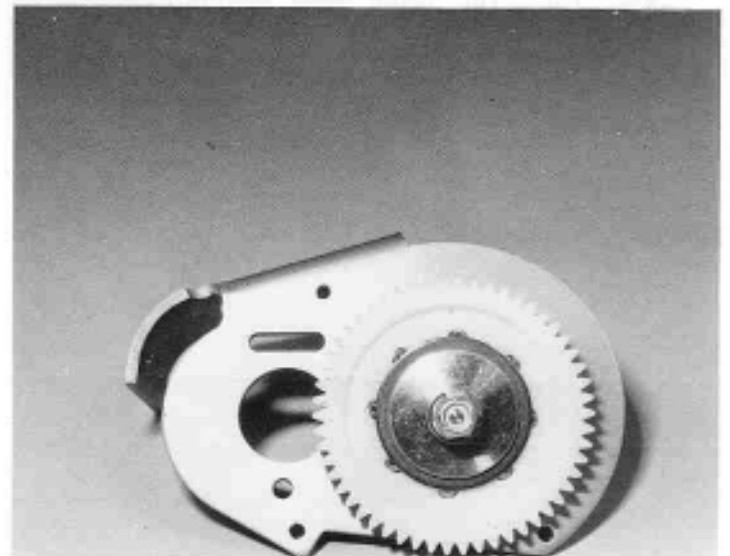

Fig. 83

-84- Make sure the bearing adaptor is properly seated in the motor mount. Take out the #6605 transmission housing, as shown.

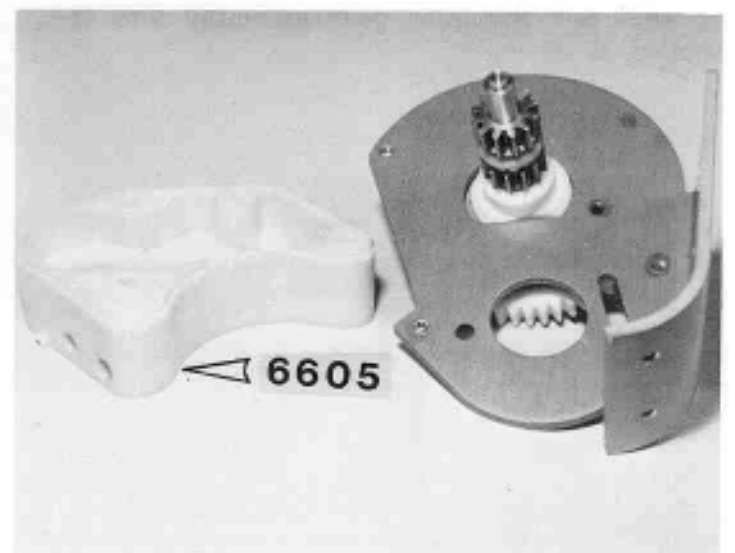

Fig. 84

-85- Slip the R.H. half of the housing onto the dif.

NOTE: There is a flat on the adapter that MUST match a flat in BOTH the motor mounting plate and the transmission case. The adapter is a tight fit in the transmission case, so you'll have to work to get it started. If you have installed it properly it (the adapter) will be in far enough to be flush on the inside of the case half-shell. The motor plate will be loose for the next 9 steps.

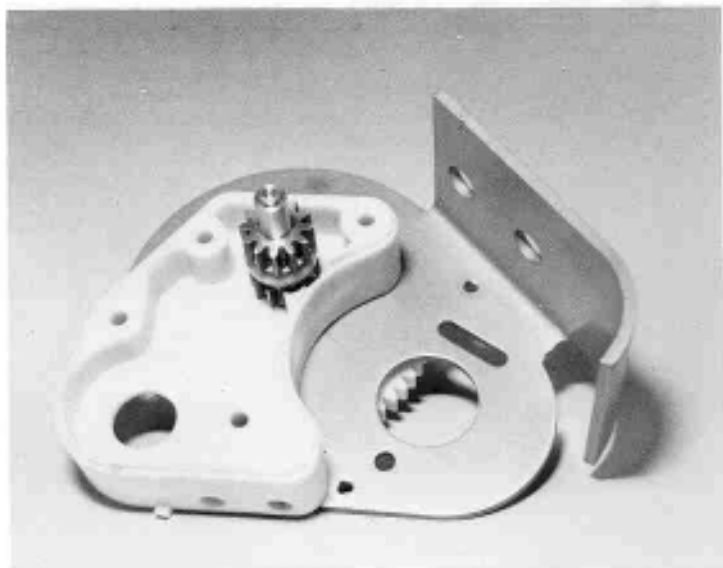

Fig. 85

-86- Take the idler gear assembly.

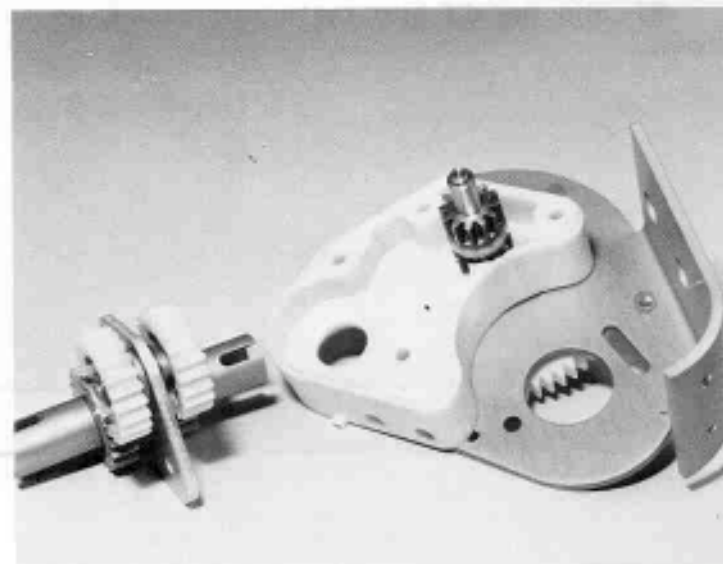

Fig. 86

-87- Set the idler gear assembly into the housing, as shown.

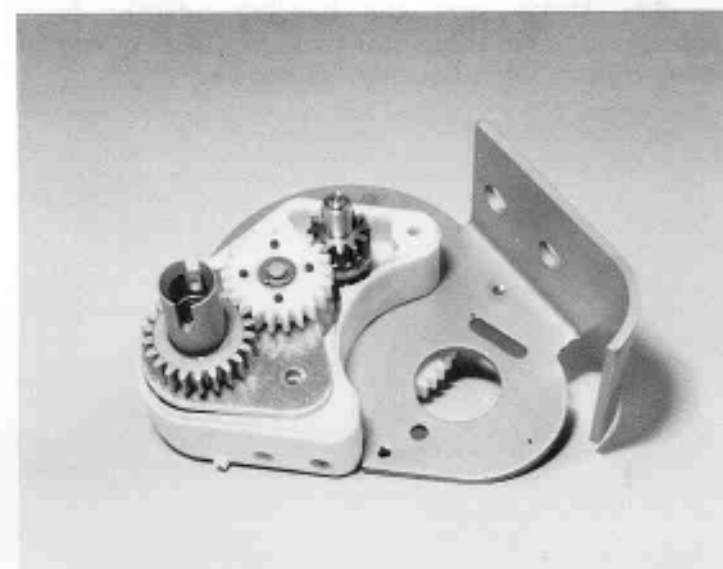

Fig. 87

-88- Take the L.H. side of the housing and push it onto the R.H. side. It will snap together with finger pressure.

NOTE: The seam between the two halves of the case should close completely with no more than a few thousandths of an inch gap showing (usually on the bottom of the case). If you cannot close the case completely look for something wrong inside.



Fig. 88

-89- Take the other bearing adaptor and cut a small notch in the edge, as shown. This will make installing and removing the "E" clip a lot easier.

-90- Install the bushing or ball bearing into the adaptor.

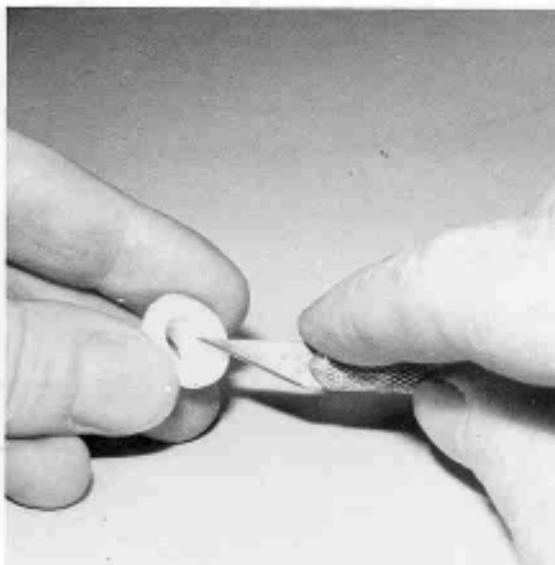

Fig. 89



Fig. 90

-91- Install the adaptor onto the dif shaft.

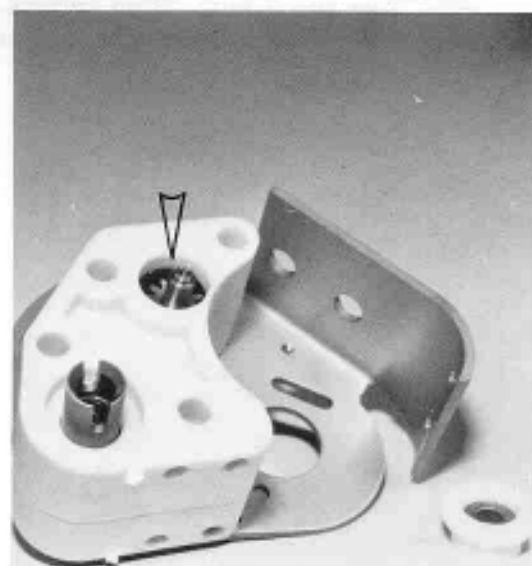
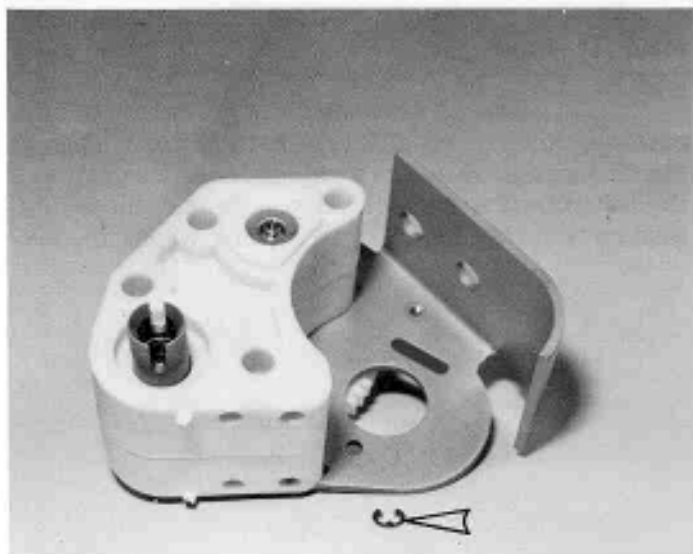

Fig. 91

**-92-** Install an "E" clip on the end of the dif shaft.



**Fig. 92**

**-93-** Make sure the "E" clip is seated correctly.

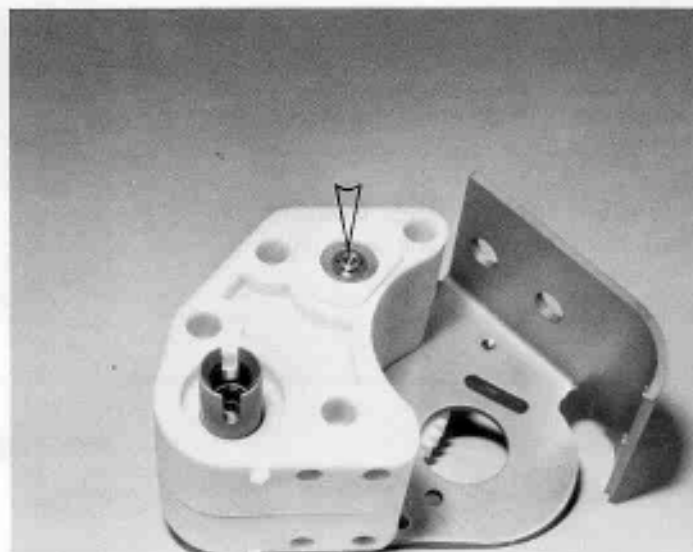

**Fig. 93**

**-94-** Take the 3 long Allen screws, as shown, and screw them into the motor mount.

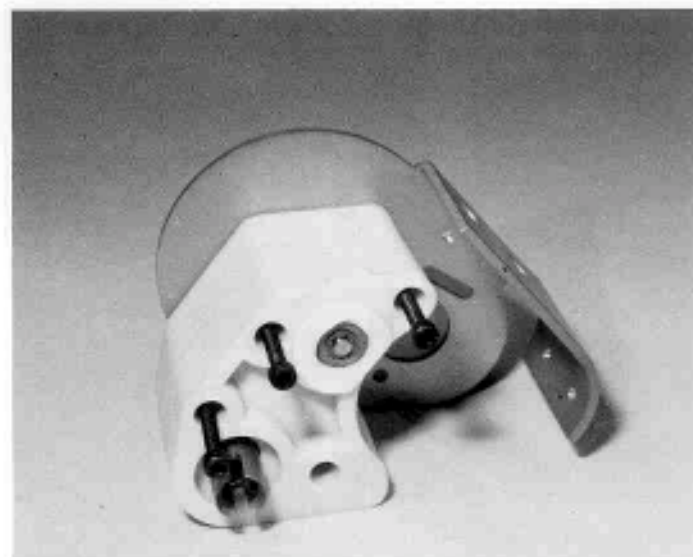

**Fig. 94**



-95- Take the other short screw, then slip a 4/40 nut into the hex hole, as shown, and tighten this screw.

NOTE: After assembling the transmission with bushings for the first time the large gear may be hard to turn. You can free things up by giving a sharp blow to each END of the dif shaft using the plastic handle of a screwdriver as a hammer. A few raps on the adjustment nut followed by a few against the adapter on the other side will help to align the bushings. Once you start running the car the bushings will free up completely.

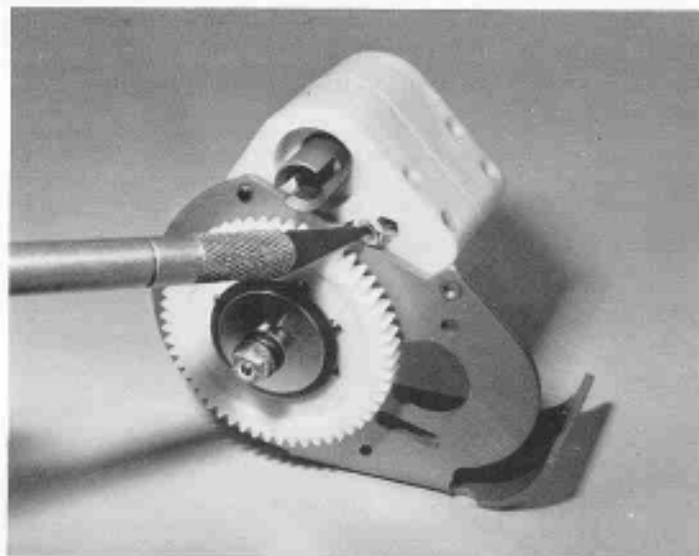

Fig. 95

-96- On the bottom of the transmission case, as shown, are 2 molding lugs. Cut these off flush with an Xacto knife.

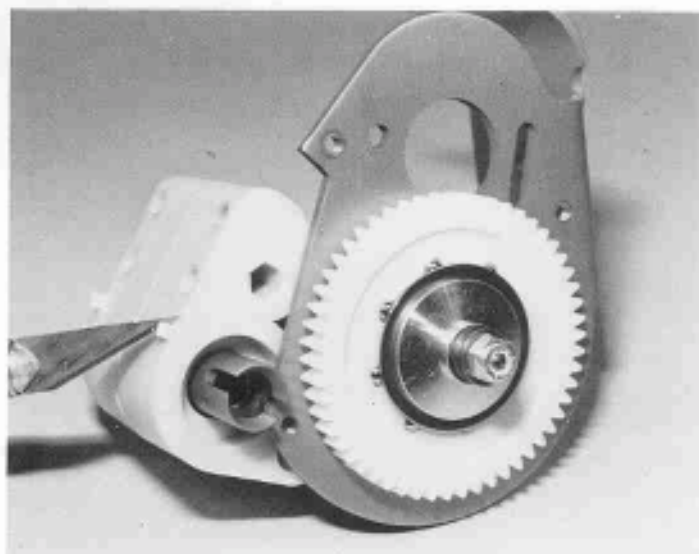

Fig. 96

-97- Take the 2 #6633 felt seals out and slip them on the hubs, as shown.

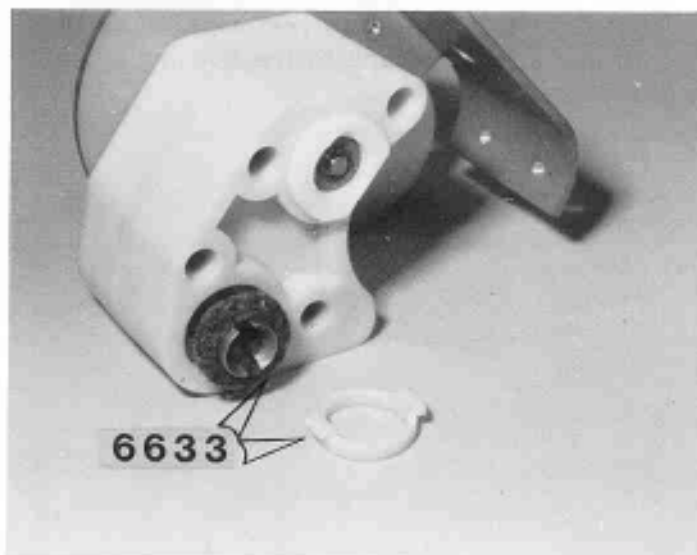

Fig. 97

-98- Now push the 2 felt retainers on. They should snap in. "Ears" should be horizontal. If they're loose, use a drop of contact cement to hold them in.

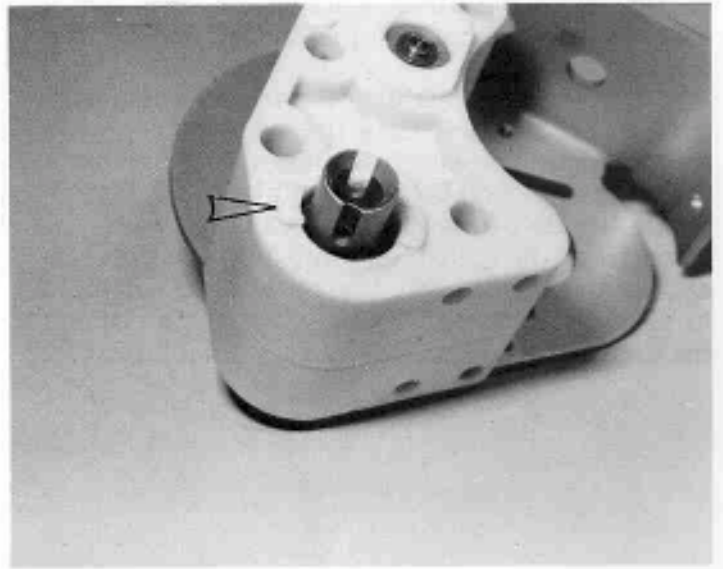

Fig. 98

-99- Take the sheet of double sided contact tape and cut a piece, as shown in #100.

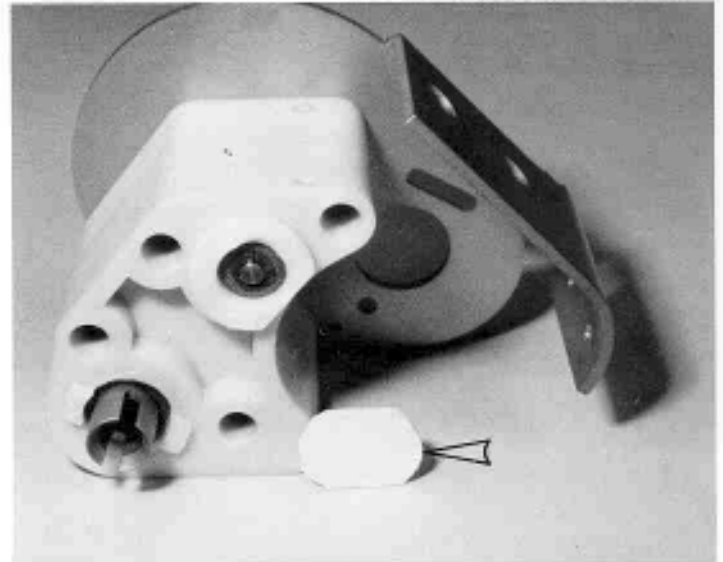

Fig. 99

-100- Pull the easiest to remove side of the tape off and stick the tape to the housing to act as a dust cover.

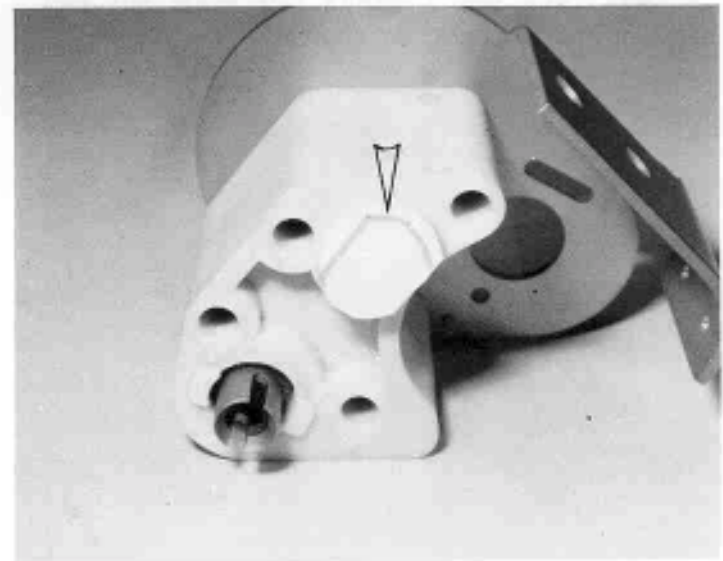
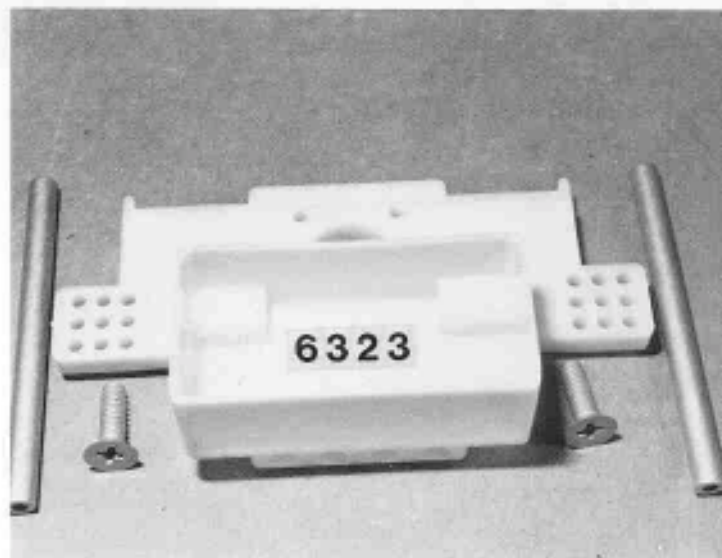

Fig. 100

**-101-** Take the #6323 rear bulkhead out, and the 2 #6327 wing tubes. See photo #103. The wing tubes are the short tubes. Take these, round off the square cut corners on the ends with a file, and tap the wing tubes into the bulkhead.



**Fig. 101**

**-102-** Take the 2 Phillips screws and attach the bulkhead to the chassis, but **DO NOT** tighten the screws all the way down yet, but almost tight. Then install the 2 4/40 Allen screws, as shown, but do not tighten these down yet. We'll be tightening these 4 screws down later.

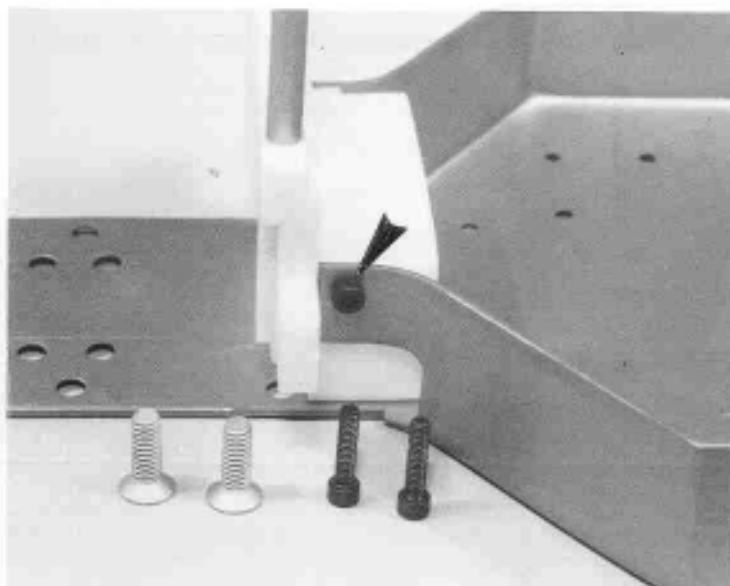

**Fig. 102**

**-103-** Install 2 ball ends into the upper, inner holes, as shown.

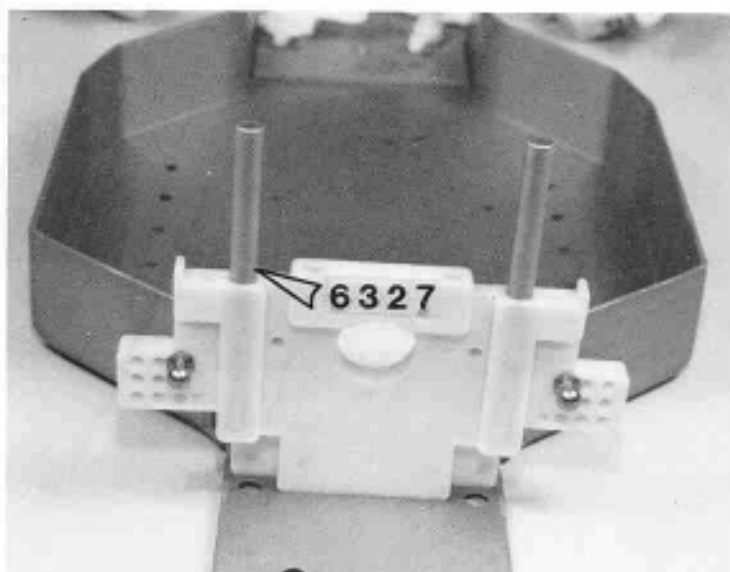

**Fig. 103**

-104- Take the transmission housing and install it with 4 Phillips screws. Do not tighten the screws all the way yet. Be sure the motor mount plate is INSIDE of the chassis at the back, as shown.

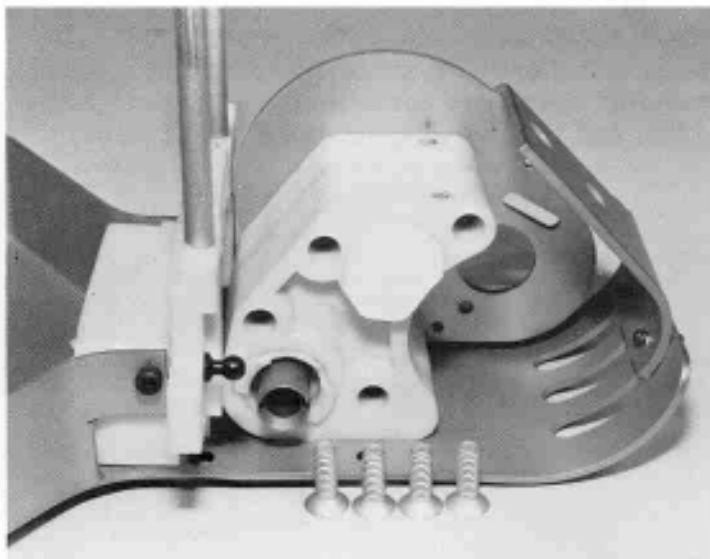

Fig. 104

-105- These 6 screws should be loose yet.

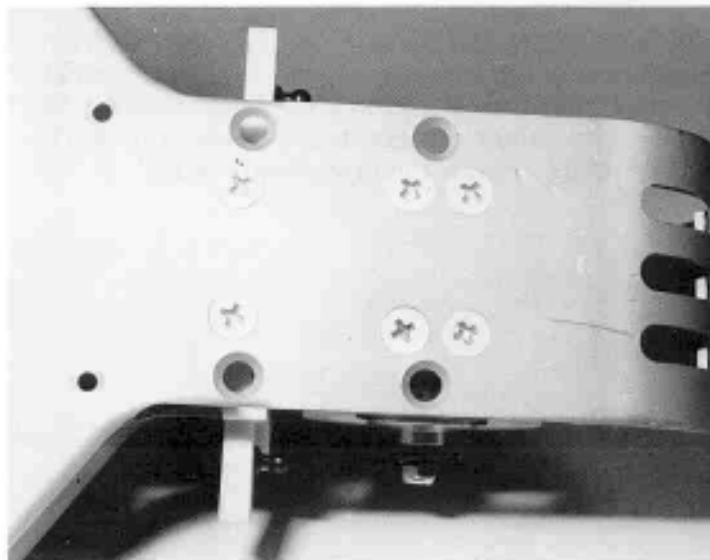

Fig. 105

-106- Take the #6325 transmission brace and install the rear body mount with 2 of the thick washers under the mount.

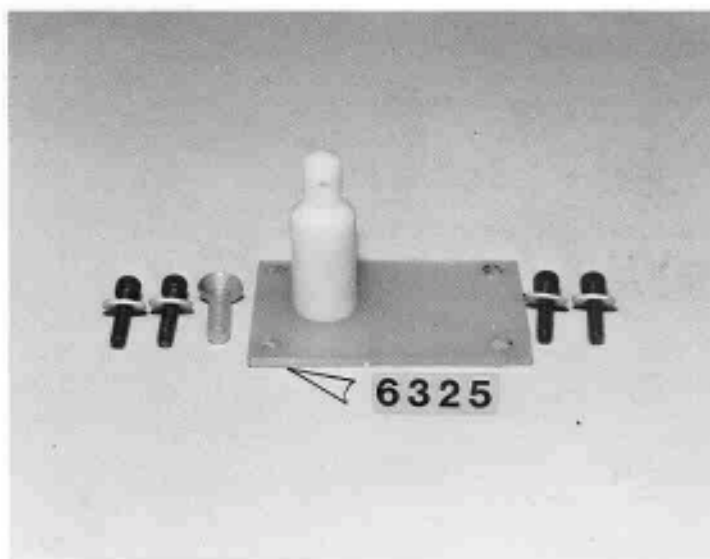

Fig. 106

**-107-** Install the transmission brace with 4 Allen screws and washers, as shown, but do not tighten all the way down yet.

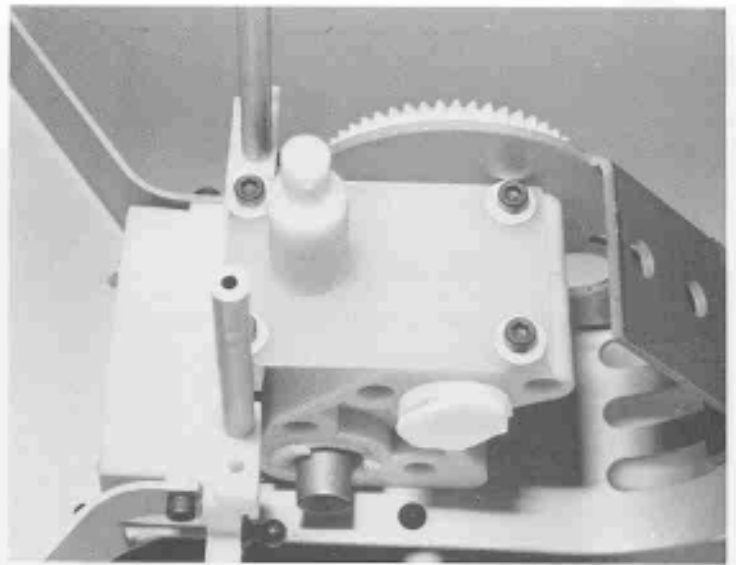

Fig. 107

**-108-** Attach the rear of the chassis plate to the motor mount with 2 short Allen screws and tighten down. Now go back and tighten down all the screws in photos #101,102,104,105 and 107. Be careful when tightening screws into plastic. As soon as they feel like they're starting to tighten up - stop - so you don't strip out the plastic.

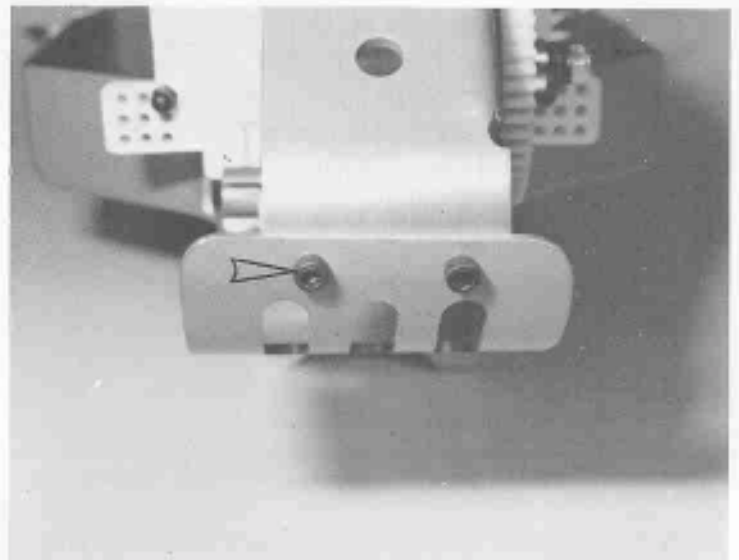

Fig. 108

**-109-** Take the #6360 rear suspension mount, out of bag 68, with the letter "L" on the bottom, the #6355 L.H. rear "A" arm and the #6380 inner hinge pin. Line up the holes in the arm and mount and install the pin. Install the 2 "E" clips.

NOTE: The left and right rear mounts are attached together by a thin "runner" that should be removed with scissors.

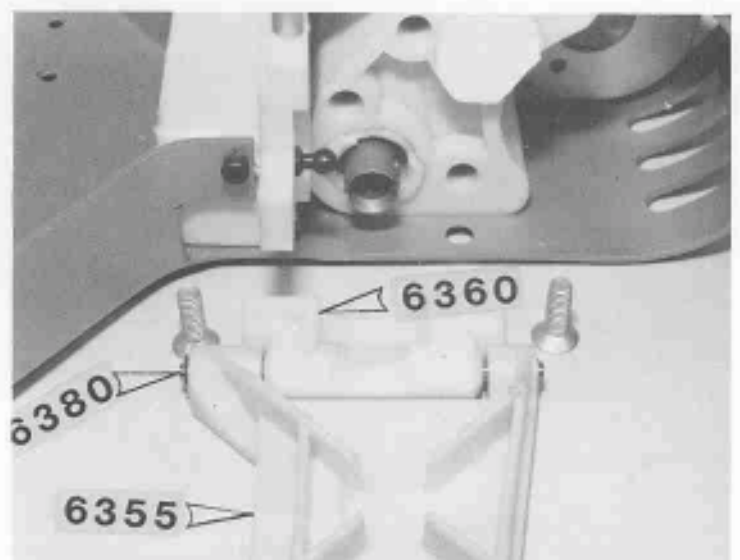

Fig. 109

-110- Install the L.H. mount to the chassis with 2 Phillips screws as shown. Now, install the R.H. arm.

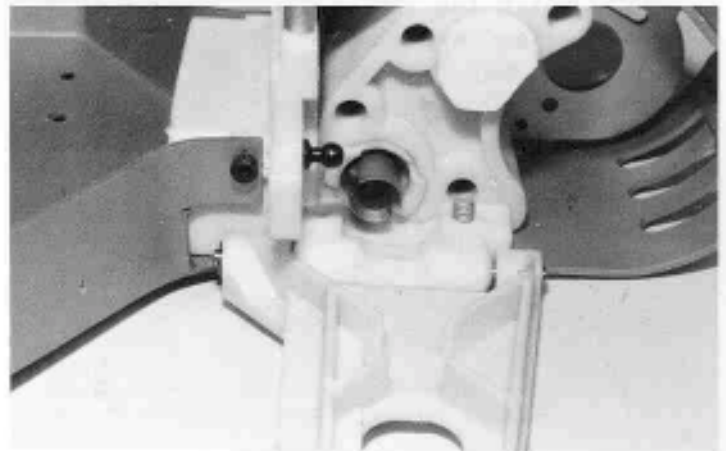

Fig. 110

-111- Before proceeding with the assembly of the rear hub carrier it's a good idea to check fit of the dogbone in the stub axle. If it does not slide and swivel freely then check for burrs around the dogbone pins or heat treating residue inside the stub axle. Also check that the spring fits freely in the small hole at the bottom of the dogbone socket (see Fig. 117). If either of these holes are clogged they can be cleaned by soaking the stub axle in hot or boiling water for a half hour. Dry and oil the stub axle after cleaning.



Fig. 111

-112- Take the #6374 rear stub axle and slip the flat washer, as shown, onto the axle. Install the bushing into the #6365 rear hub carrier in the direction shown. If you're installing ball bearings, install one of the large #897 bearings on each side of the #6365 hub carrier, and remove the flat washer from the axle. It is only used with bushings. Oil the bushing and slip the axle into the bushing. Now take the cone washer, the one that is not flat, and slip it on the shaft so that the part that touches the bearing is the center of the washer.

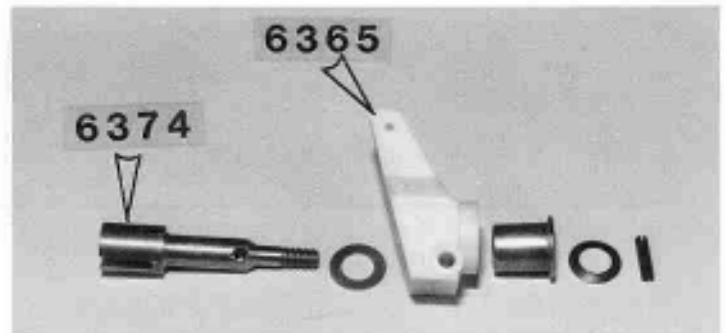

Fig. 112

-113- For this step you may need 3 hands, so get a friend to help you. Set the axle on a vise or a flat surface. Hold the roll pin or slotted pin with a needle nose pliers and align the pin with the hole in the axle. Lightly tap the pin in the axle so it's evenly spaced.

An alternate method of installing the pin is shown in Fig. 113a, using a pair of water pump pliers. Start the pin by holding with small pliers and pushing into the hole with a twisting motion. Finish with large pliers as shown. Angle the pliers slightly to allow the pin to come through the other side.



Fig. 113a

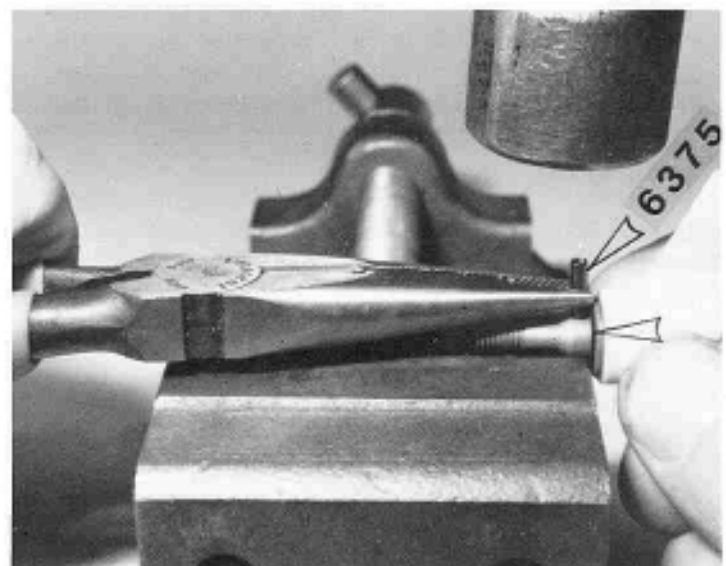
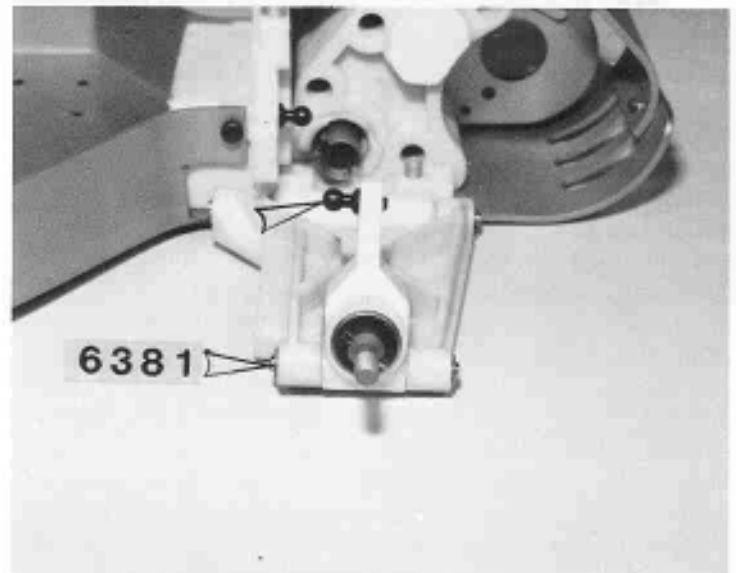

Fig. 113

**-114-** Install the hub carrier in the "A" arm with the #6381 outer hinge pin. Install 2 "E" clips. Install a ball end in the forward side of the hub carrier, as shown. Install the R.H. hub carrier.

**NOTE:** The pin is intentionally a tight fit in the hub carrier; do not ream the hole. The pin will turn in the A-arm.



**Fig. 114**

**-115-** Your L.H. rear end should look like this now.

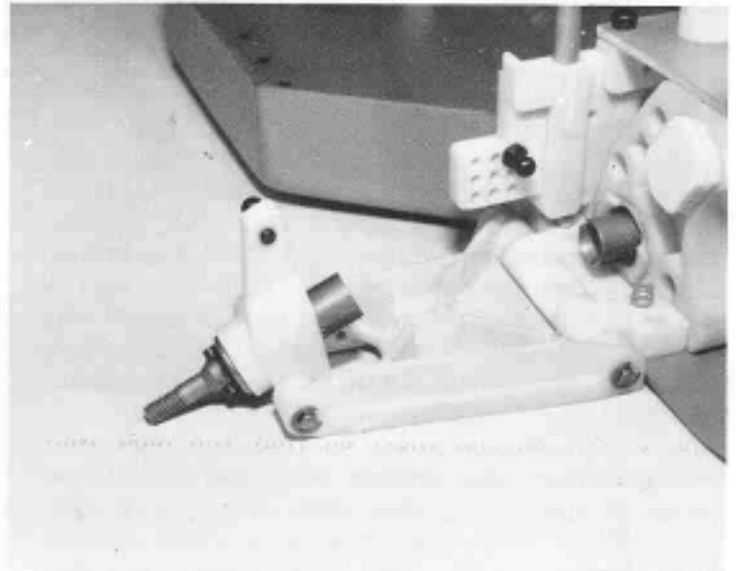

**Fig. 115**

**-116-** Take the 2 #6385 threaded rods and screw 2 plastic rod ends on each to a dimension of 1.600" or 40.64 mm. This is measured to the center of the ball again. Note that on this strut one ball faces forward and one faces to the rear.

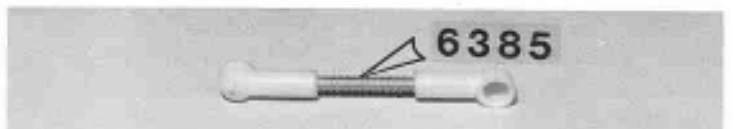

**Fig. 116**

**-117-** Take out the #6372 spring and nylon washer and the #6370 dogbone or rear half-shaft. Push the nylon washer into the #6612 gear.

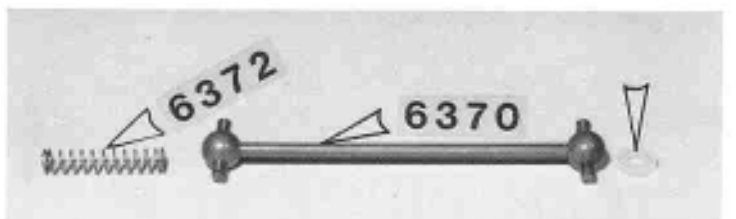

**Fig. 117**

-118- Put the #6385 strut onto the ball on the bulkhead. Put the spring inside the stub axle, and make sure the spring fits freely in the hole. If the spring binds you may be able to clear the hole with an Allen wrench; or you can reread step 111. Put the dogbone or half-shaft into the gear slot. Now, align the stub axle with the dogbone and slide it in. Put the strut on the ball in the hub carrier. It should look like Fig. 118 now. Do the R.H. side.

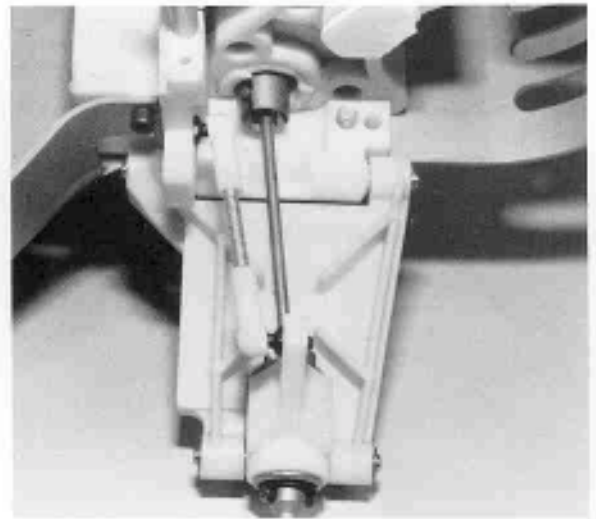

Fig. 118

-119- Take bag #69 and we'll assemble the rear shocks now. Take out the parts, as shown.

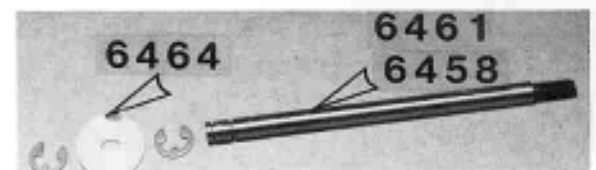

Fig. 119

-120- Slip on one "E" clip.

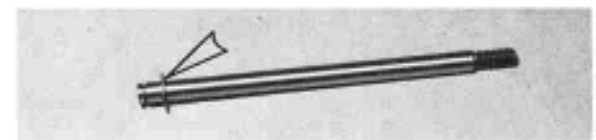

Fig. 120

-121- Slip on the #6464 piston and then another "E" clip. Make sure the "E" clips are fully seated. Now cut a 5/8" (16 mm) length of 1/8" dia. silicon fuel tubing and push it onto the shaft from the threaded end. Push the tubing all the way up to the piston. This will add a rubber "downstop" to your rear shocks which will prevent the wheels from dropping down too far and possibly breaking a dogbone. Add the rubber tubing to the REAR SHOCKS ONLY.



Fig. 121

-122- Take the number 6452 and install the parts in the end in the order shown (see also Fig. 122a). First, push the small nylon washer in all the way to the stop. Next push in one red "O" ring. Then the nylon spacer, and now the 2nd red "O" ring. Then the large nylon washer. Now install the large inner "C" clip. Start one end of the clip in, hold it down with your finger. Now, with a small screwdriver, push the other end over and in. If you have trouble installing the clip try this other method: Start one end of the clip in and hold it down with your left thumb nail. Now start working your right thumb nail around, pressing the ring into the hole as you go. By the time you get to the other end of the clip it will snap into the groove.

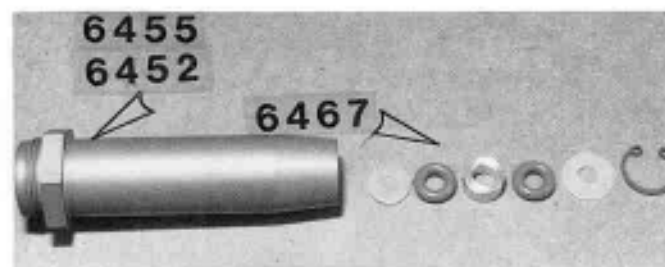

Fig. 122 Fig. 123

-123- Make sure the clip is fully seated.

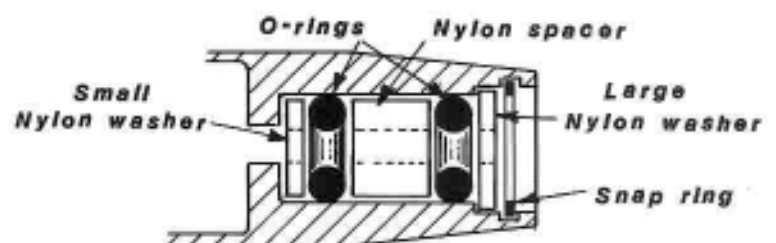

Fig. 122a



-124- While holding the shock body upright as shown, block off the hole at the bottom with your finger and put about 10 drops of oil into the shock body to lubricate the "O" rings. Now, very carefully and smoothly, push the shock shaft down through the shock body and through the "O" rings. You want to do this carefully so you don't cut the "O" rings which will make the shock leak. Release your finger from the bottom and pull the shaft SLOWLY all the way through until the piston bottoms out. While still holding the body upright, fill the body with the shock oil to within 1/32" (0.79 mm) of the top. Note - on the front shocks, which are shorter, you can fill the oil all the way to the top of the body.



Fig. 124

-125- While holding the body upright, slip the large nylon washer down over the threads. Now screw the #6463 cap down over the body.

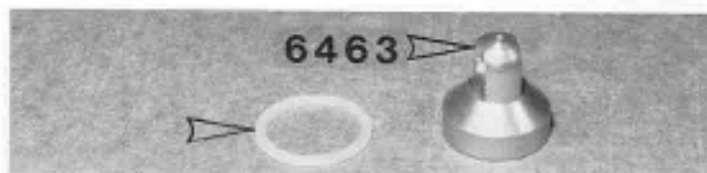

Fig. 125

-126- You can use a 1/2" wrench, or the Associated #6955 shock wrench to hold the nut, then stick a rod through the cap and tighten it down.

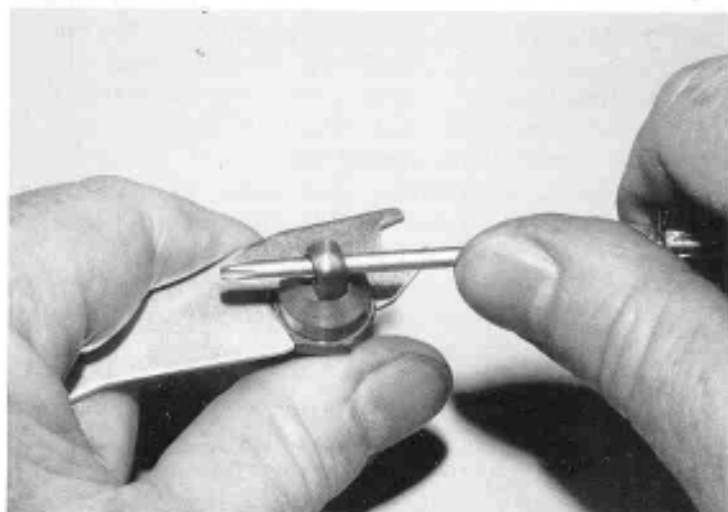

Fig. 126

-127- Your shock should look like this. Now do the other rear shock and the 2 front shocks in bag #610. Remember that the front shocks don't use rubber fuel tubing.



Fig. 127

-128- Your front and rear shocks should look like this, and they should all feel quite smooth when you move the shafts in and out.

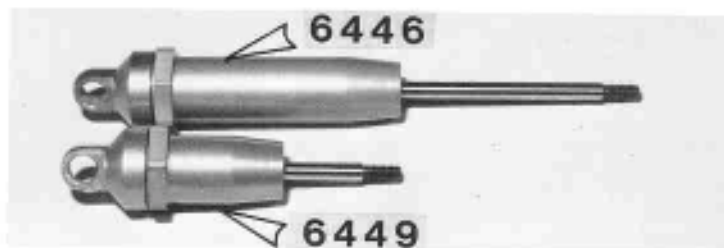

Fig. 128

**-129-** Install the 2 #6474 spring clamps on the rear shocks. Install one with the screw head up, as shown, and the other with the screw head down. There should be a 1/4" (6.35 mm) space between the collar and the body hex nut. Tighten the screws just enough to lock the collars. DO NOT overtighten. Slip on the long silver #6478 spring. There is also a long gold spring, which is stiffer than the silver spring. The silver spring will work best on most tracks, but you can experiment with the gold spring also, on your track. Take the #6471 plastic rod end and push it onto the metal ball. The easiest way to do this, is to lay the metal ball end on a table, with the flat end on the table. Set the plastic end on the ball and push it in place with your 1/4" nutdriver. Slip the spring holder on the shaft and into the spring and collapse or squeeze the spring. Then thread the plastic ball end on the shaft. You'll have to keep the shaft from rotating with a needlenose pliers. Grab the shaft close to the threads so that you don't scratch the part that rides in the "O" rings.

**-130-** On the front shocks, install the spring collars all the way up, as shown. Use the short gold spring, which is stiffer than the short silver spring. Again, you can experiment with both springs, but start with the gold spring. Install the spring cups that go inside the springs, as shown, and then install the plastic ball end. Your shocks are now complete.

**-131-** Now we'll install the front shocks on the car. The arrow in the photo is pointing to the upper mount. Install one of the Allen screws through the fiberglass shock strut, from the rear. Some kits have two holes at the top of the strut. In that case use the LOWER hole. Now screw down and tighten one of the 4/40 plain nuts. Now slip a plain aluminum washer on. The arrow is pointing to the flanged nylon shock bushing. Slip this bushing on next, with the flanged end on first.

**-132-** The #6224 lower shock pin, from bag #61, has a notch for the Allen set screw to lock in place. The notch will go toward the rear of the car.

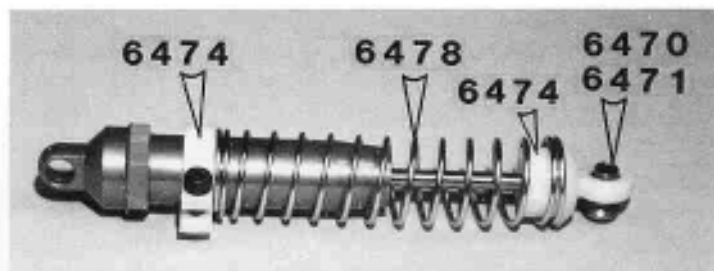

Fig. 129

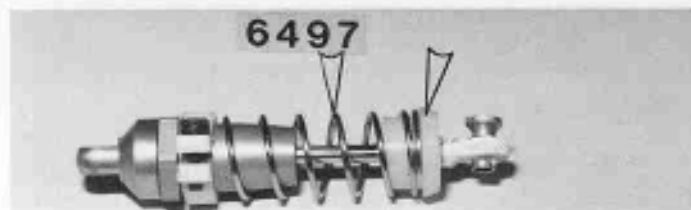

Fig. 130

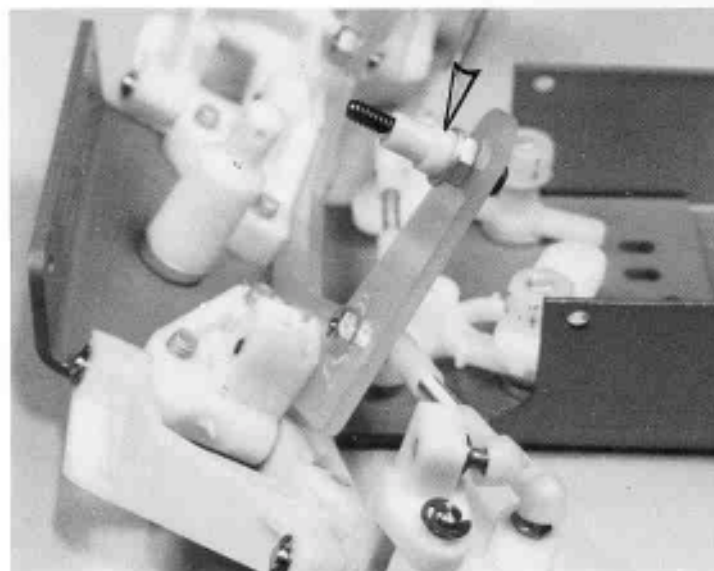

Fig. 131

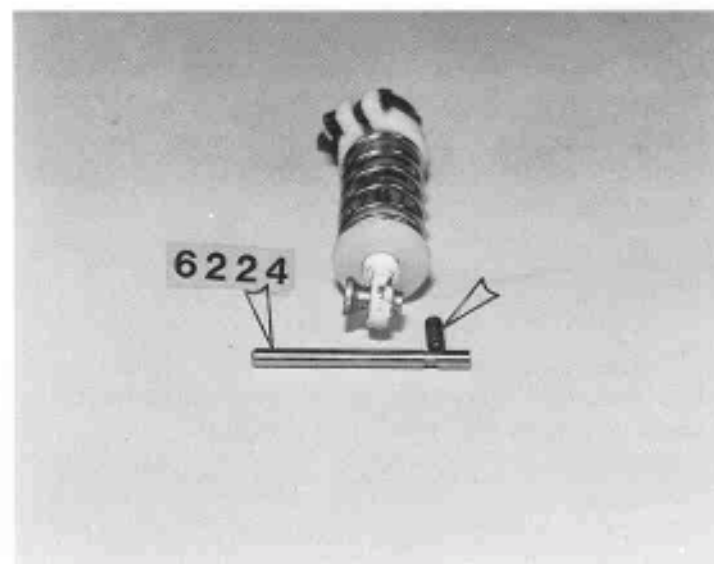

Fig. 132

-133- Slip the shock on the upper mount and install a locking nut. DO NOT tighten down too tight on this nut or you'll bind up the shock. Squeeze the bottom end of the shock up and then slip the end down into the lower "A" arm slot, with the flat side of the ball forward. Now, from the rear side of the "A" arm slip the #6224 shock pin through the "A" arm and through the shock ball end. Now, in the location where the arrow is pointing in the photo, install the long set screw until it locks the pin in place.

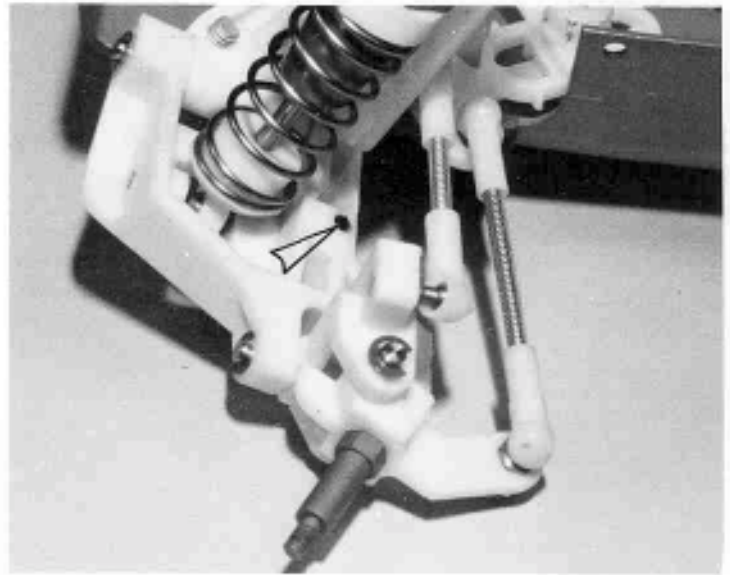

Fig. 133

-134- The lower installation should look like this.

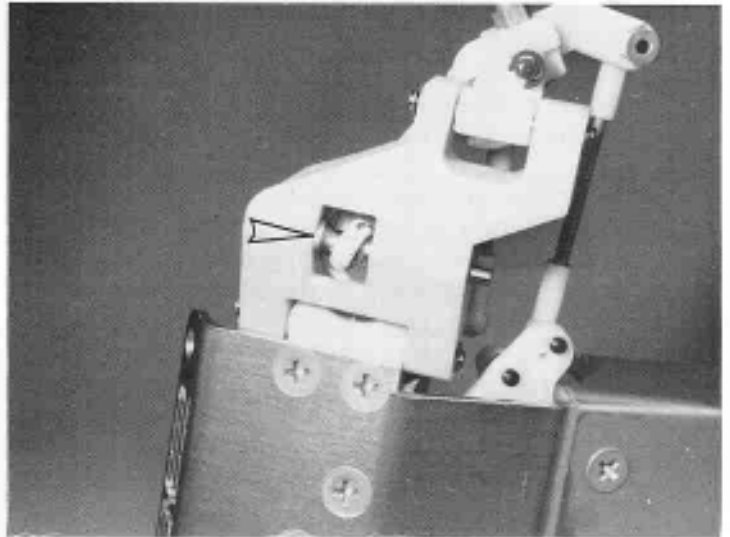

Fig. 134

-135- Install the R.H. shock.

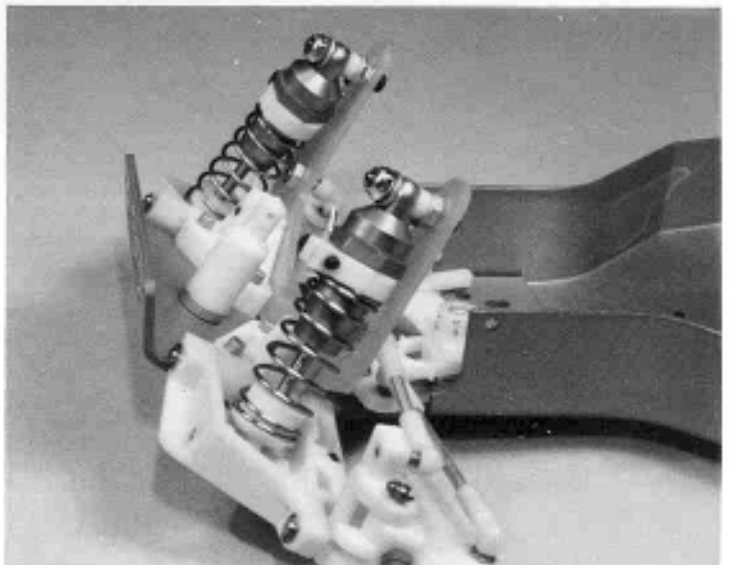

Fig. 135

-136- In bag #63 are the parts to make the front anti-roll bar. In the rear of this pamphlet is a diagram of the anti-roll bar. Install a ball in the lower "A" arm in the location shown in the photo. Do the R.H. side too.

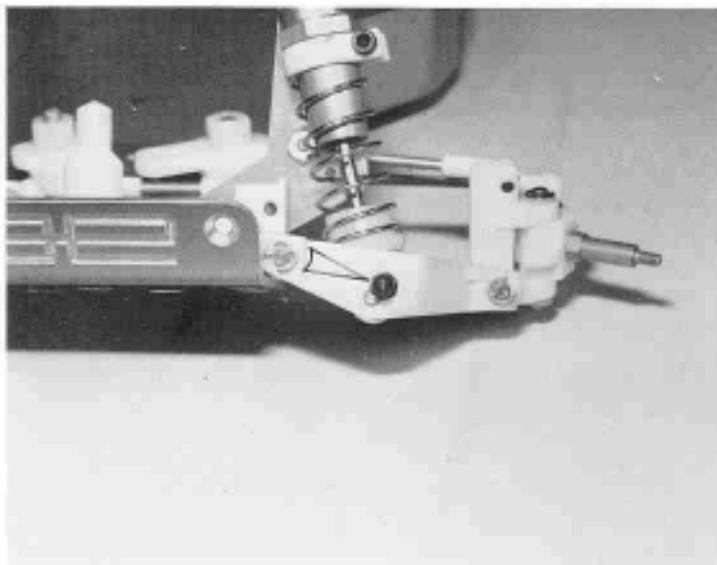

Fig. 136

-137- You'll have to form the anti-roll bar wire to fit in the groove as shown in photo #138, and in drawing Fig. 219 in the back of this booklet. It must have ample clearance from the shock springs. Now solder the ball rod ends onto the wire. You'll find that ACID core solder works best for this (or acid flux). But the bar should be cleaned in hot water afterwards. Acid core MUST NOT be used for any of the electrical connections. You'll have to screw the plastic ball ends down so they touch each other on the threaded rod. This can be done easier if you cut about 1/4" (6.35 mm) off of the rods to shorten them.

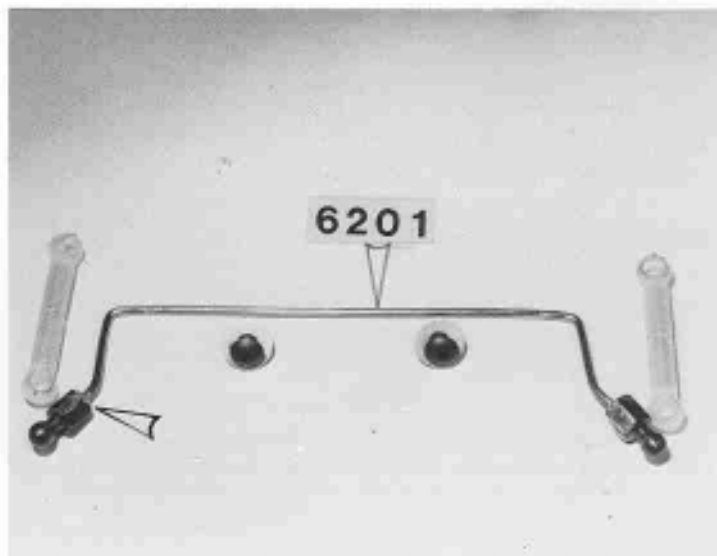

Fig. 137

-138- Set the anti-roll bar in place and locate it with the 2 button head Allen screws and 2 washers.

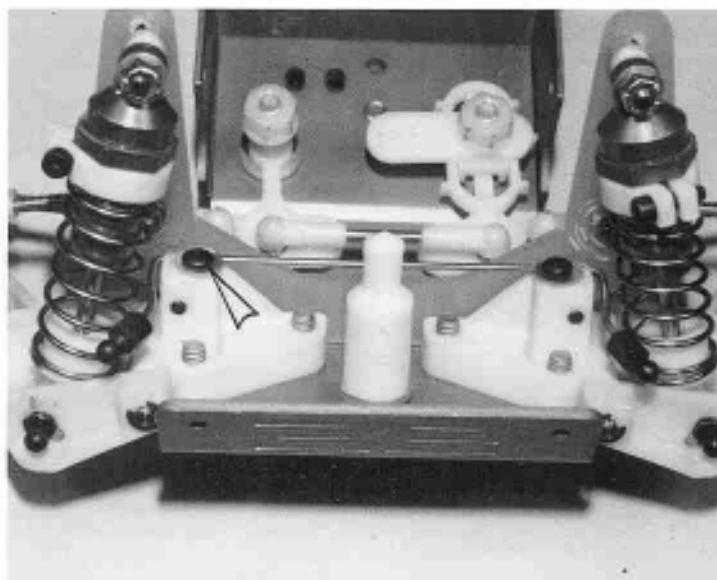

Fig. 138

-139- Now snap on the 2 plastic rod ends.

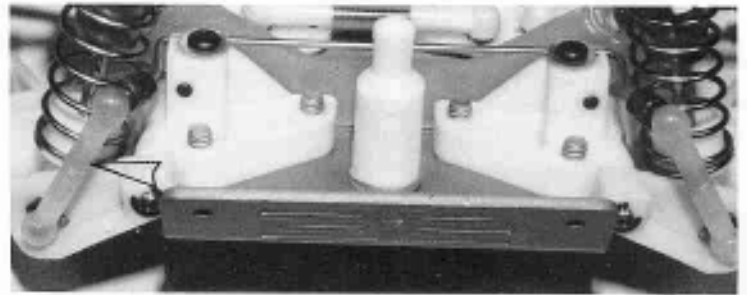

Fig. 139

-140- In bag #64 is the 2 #6320 nose brace tubes of 4 Allen button head screws, as shown.

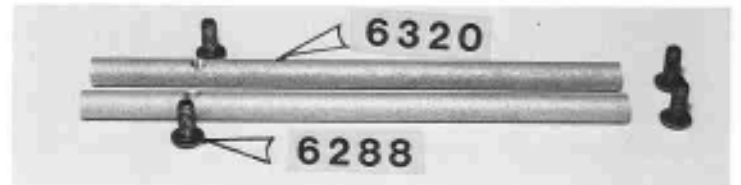

Fig. 140

-141- These tubes tie in the nose piece very solidly to the chassis. Start by installing the rear screw through the side of the chassis, but do not tighten yet. Install the forward screw through the front of the nose piece into the end of the rod and tighten down. Now tighten the rear screw. Install the 2nd brace.

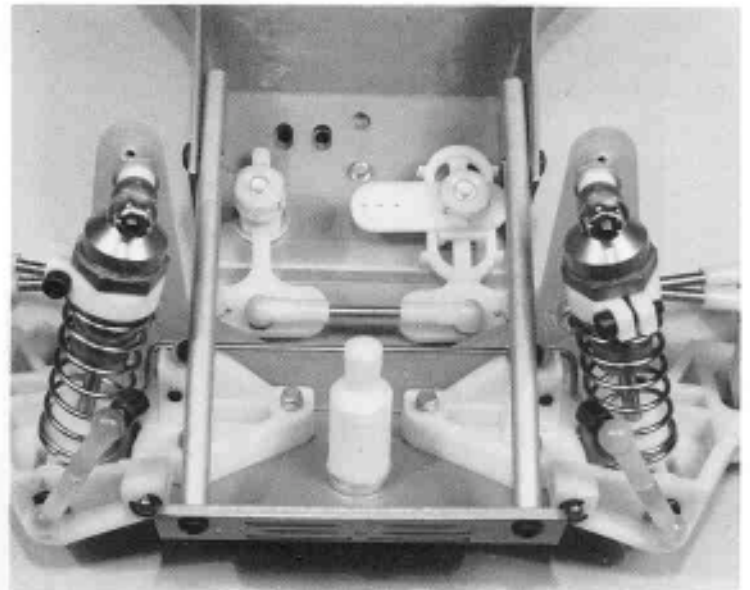

Fig. 141

-142- Also in bag #64 is the #6378 rear shock strut. Assemble this to the rear bulkhead with the 4 Allen screws, as shown.

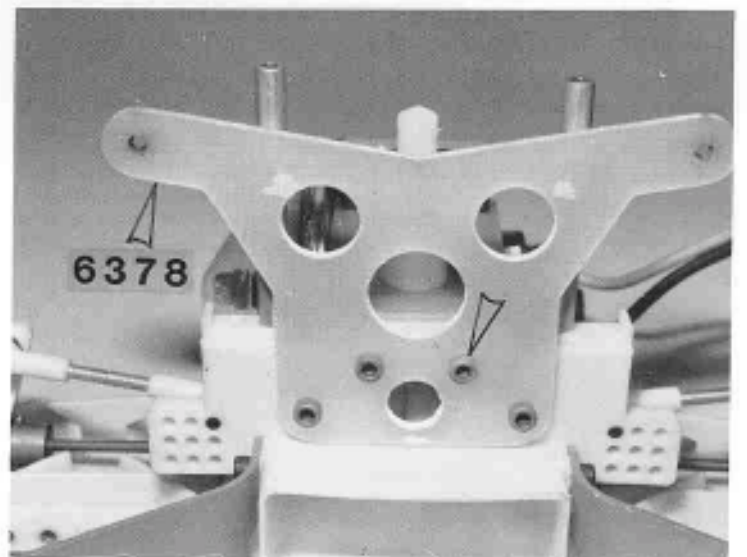
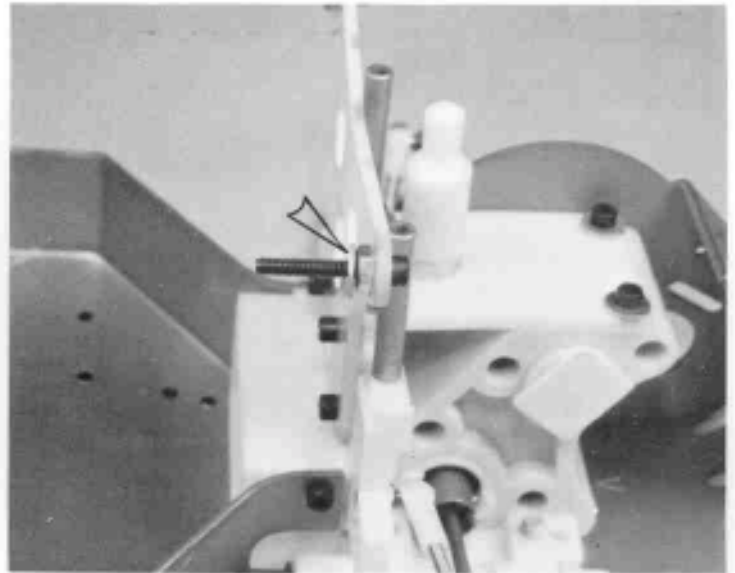

Fig. 142

**-143-** It's time to install the rear shocks. From bag #69, install one of the Allen screws through the fiberglass strut from the rear. Then, install a plain nut and an aluminum washer next. Slip a bushing in the shock, with the flange forward, and slip the shock on the screw.



**Fig. 143**

**-144-** Install a locking nut next. Do not overtighten the nut, it is only necessary for the nut to take up the end play.

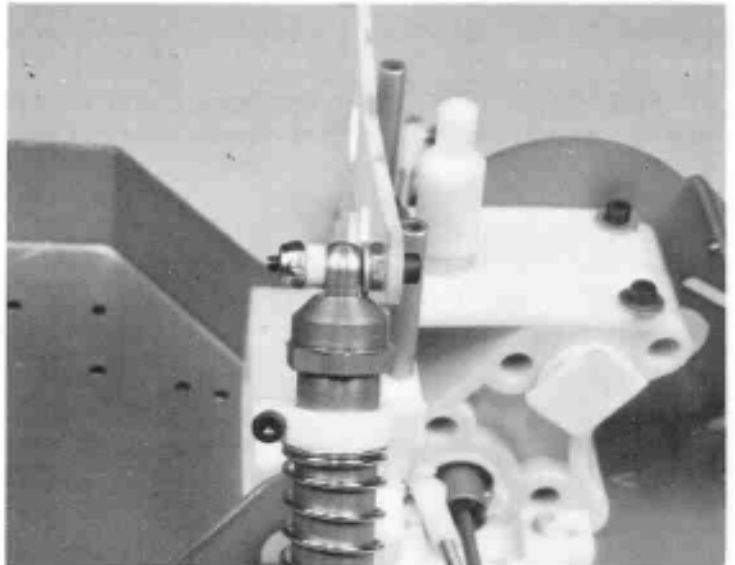

**Fig. 144**

**-145-** For the shock bottom installation we want the flat part of the metal ball end to be against the "A" arm, as shown. In the "A" arm, there are 4 holes. Do not install it in the outside hole, but use the next hole inside, as shown. Slip a washer on the screw, and install the screw.

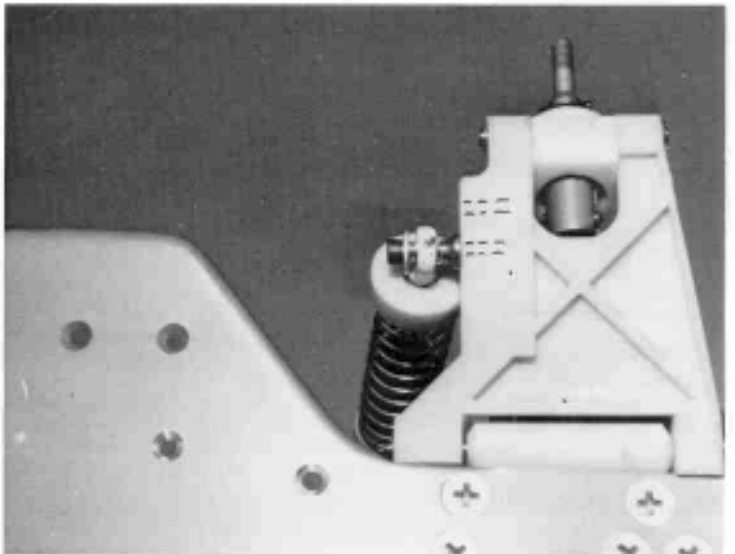

**Fig. 145**

-146- Time to put the horsepower in the car. Using ROSIN core solder, solder the motor lead wires and filter capacitors to the #6500 motor, as per the instructions included in the motor bag (see also Fig. 146a). From bag #615, take the #6659 motor pinion and install the pinion, as shown. The end of the pinion should be even with the end of the shaft.

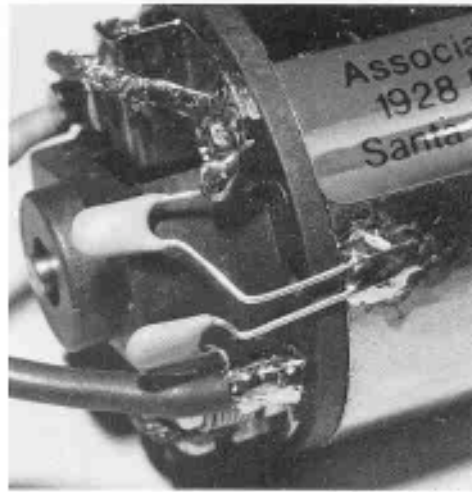

Fig. 146a

-147- In the motor bag are 2 metric motor mounting screws. These screws have finer threads and are only used to mount the motor. Slip the motor in the motor mount and start the bottom screw in first. Do not tighten all the way down yet. On the top screw, put a washer on the screw and screw it in, but not tight. Now we'll set the gear mesh. By moving the upper screw, forward or back, we'll be moving the motor closer to, or away from the plastic spur gear. What we want to do is to get the metal pinion gear as close to the plastic spur gear as we can without binding up the gears. The easy way to check this is to put your finger on the plastic gear and see if you can rock it in the teeth of the metal gear. The 2 gears should be as close as possible, while still being able to very slightly rock the plastic gear. When you have this correct spacing, tighten down on the 2 motor screws and re-check the gear spacing. An incorrect gear mesh can result in a huge power loss, so do it correctly.

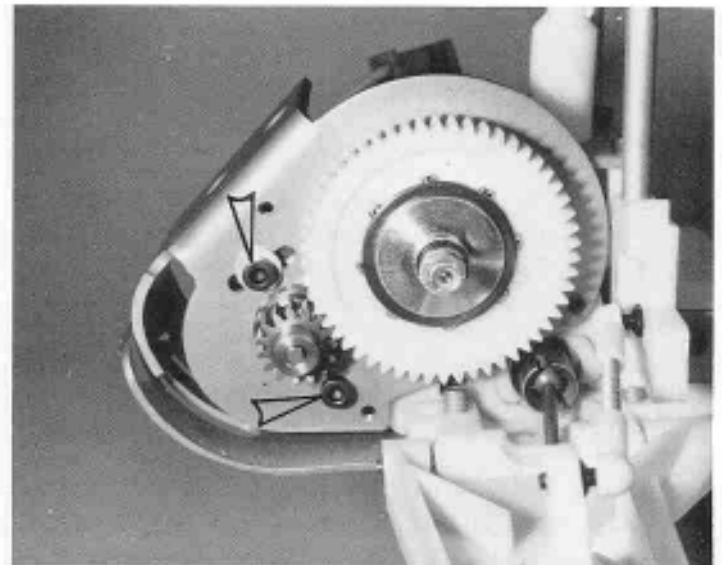
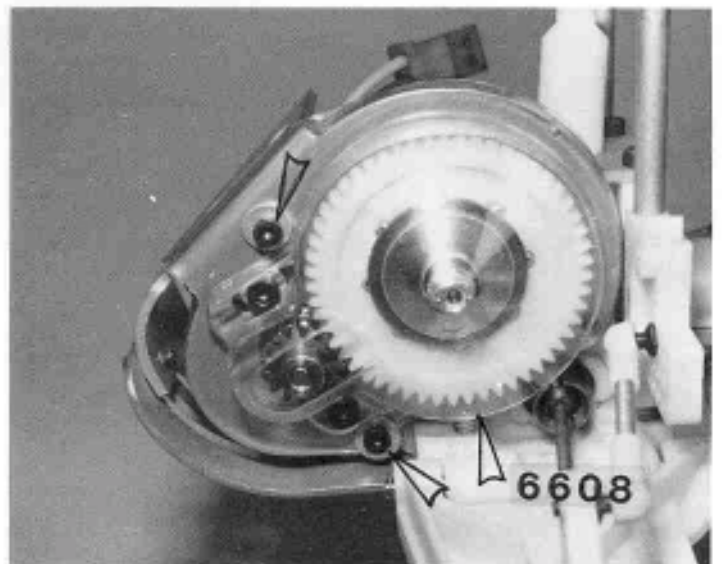

Fig. 146

Fig. 147

-148- Now we'll install the #6608 dust cover, in bag #612. You'll have to trim the dust cover to fit, with a scissors. But we want the dust cover to fold over the edges of the motor mount as far as possible. So slip the dust cover on, see where you have to trim and only cut off as much as you have to until you can snap the cover on. When the cover is on, you'll notice 2 indentations in the plastic where the 2 screws go. If you take an Xacto knife and twist it as you push, you can cut the 2 mounting holes in the plastic, or you can use a drill. Install the 2 mounting screws with washers, as shown.



CAUTION: To remove the motor, you must first remove the dust cover. You will then have 4 screws out that look the same. But if you mix up the dust cover screws with the motor screws, you will strip out the threads. Keep the motor screws with the motor, and the dust cover screws with the dust cover. Also, DO NOT try to use aluminum screws to attach the dust cover because they will break off in this installation.

Fig. 148

## RADIO INSTALLATION

We're ready to install the radio. If you haven't purchased a radio yet a good choice would be one of the 2-channel steering-wheel systems made by Futaba or Airtronics. However, many other radios, including stick models, can be used in the car. The higher torque medium sized servos (like the S31, S131, or S28) are preferred for steering, and small servos like the S32 are best for the throttle; but all three sizes, small, medium, and large, can be made to work. The photos that follow show the installation of a Futaba system with FP S32 servos. Special instructions and photos for other types of medium and large servos are also included. In these instructions servo sizes (the width of the case between the mounting ears but not including the ears) are grouped as follows:

SMALL (S32) : 1.5 in. (38 mm)  
MEDIUM (S31) : 1.6 in. (41 mm)  
LARGE (S29) : 1.8 in. (46 mm)

### STEERING SERVO

-149- In bag #66, take out 2 of the #6336 plastic servo mounts. You'll have to drill the mounts for your particular servos. If you have S32 servos, line up your servo with the mounts, so that there will be about 1/16" (1.6 mm) clearance between the servo and the chassis plate and mark the hole locations on the mounts. Drill two #43 (2.3 mm) holes in each mount on the side away from the chassis mounting hole, which will be on the bottom of the mount. You'll notice that the chassis has 2 sets of servo mounting holes. A short set and a long set. With 2 different sets and by rotating the servo mounts 90 deg, you will be able to mount most servos. Put the rubber grommets on the servo and attach the servo to the mounts with 4 button-head Allen screws and washers, as shown.

-150- Install the servo to chassis with the 2 flathead Allen screws shown in photo #149. You'll have to install 2 washers between the rear mount and chassis for proper alignment. Fig. 150a shows the proper holes to use with small servos.

-151- Out of bag #62, take the piano wire linkage and set collars. Turn the servo output arm to the left and right stops and then center the arm between these 2 stops. It will not be exact, but it will be close enough for now. We'll center it exactly with the radio later. Slip one of the "Z" bend arms in the servo arm, as shown. The "Z" bend arm will be easier to



Fig. 149

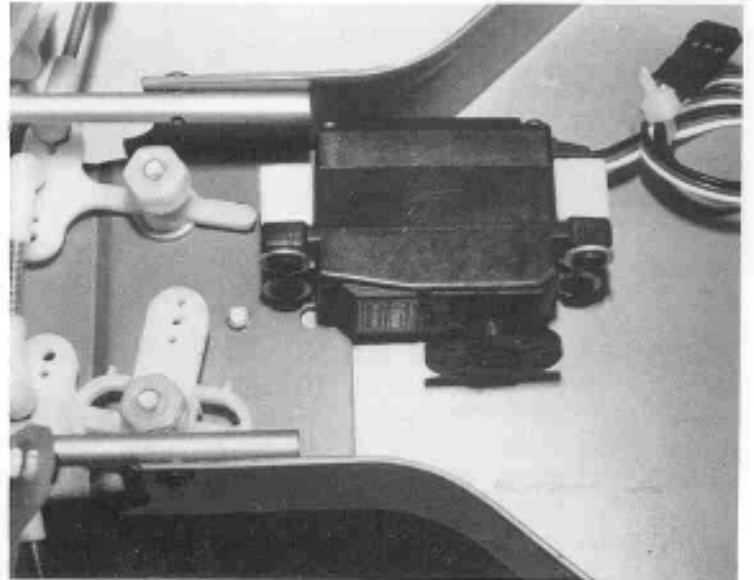

Fig. 150

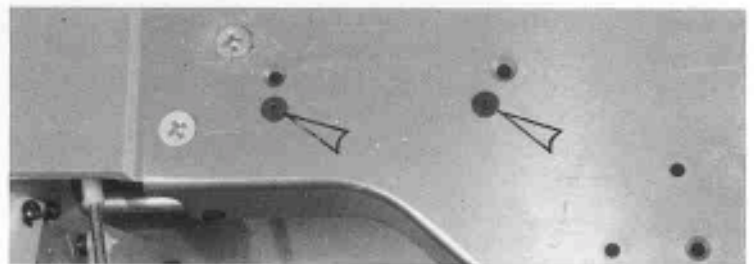

Fig. 150a

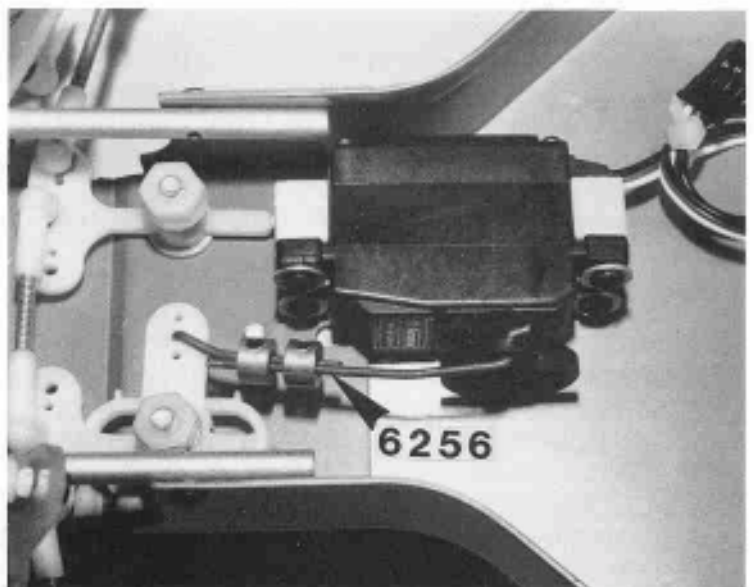

Fig. 151



install in the servo saver arm if you take your Xacto knife and rotate it in the hole to bevel it slightly. The arrow in the photo is pointing to a slight bend that we want to put in this wire to help clear the collars from the servo. Put a slight bend in the arm and then slip it in the center hole, as shown. Center the servo saver and install and tighten both locking collars.

#### Special Instructions — Medium steering servo

-152- Medium sized servos would include Futaba S31, S131, S28; Airtronic 94461; and Novak NES1A. Follow the same procedure as for the small servo but use the wider spaced mounting holes in the chassis.

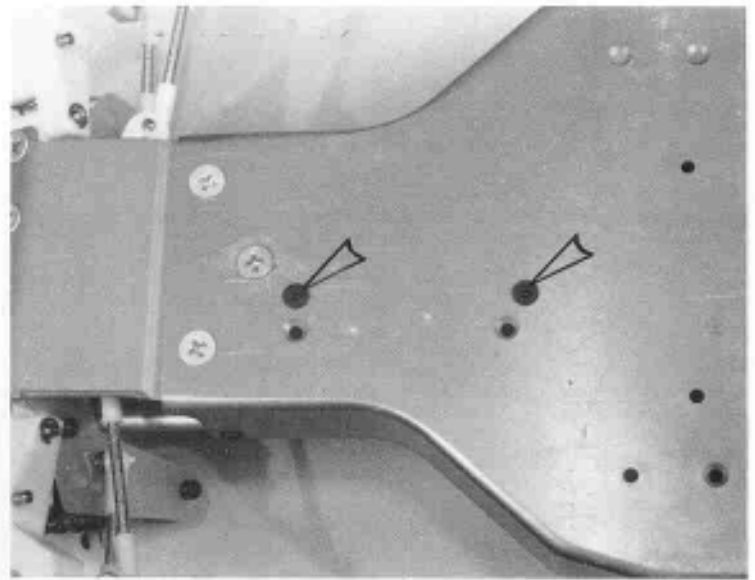

Fig. 152

-153- Linkage is the same as for small servo but may require slightly more bend.

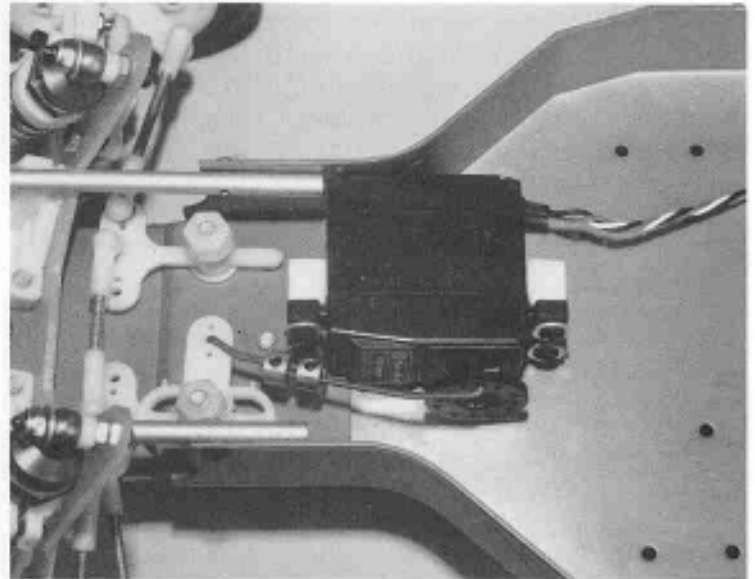

Fig. 153

#### Special Instructions — Large steering servo

-154- Large servos would include Futaba S27, S29, as well as several older designs. Follow the instructions in step 149 except that the rear servo mount should be rotated 90 degrees as shown. This will move the mounting point well away from the existing holes in the chassis to make it easier to drill another hole. Temporarily install the front mounting screw, position the servo, and then mark around the rear mount as shown in Photo 154.

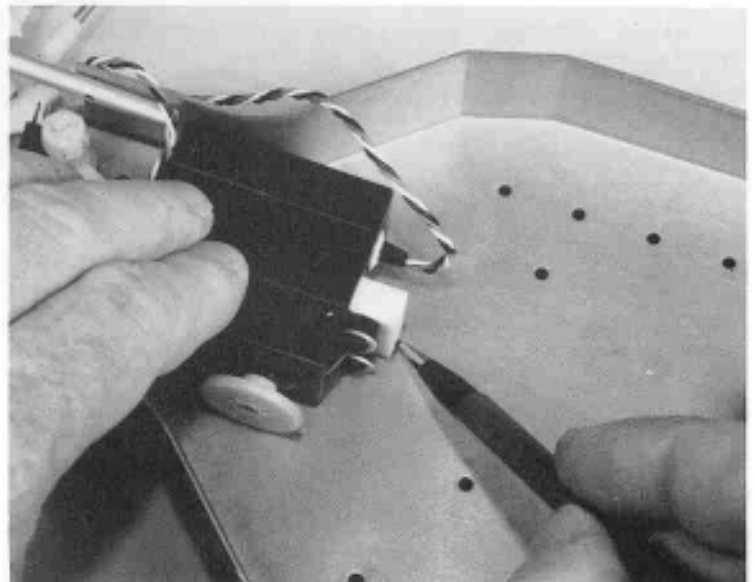
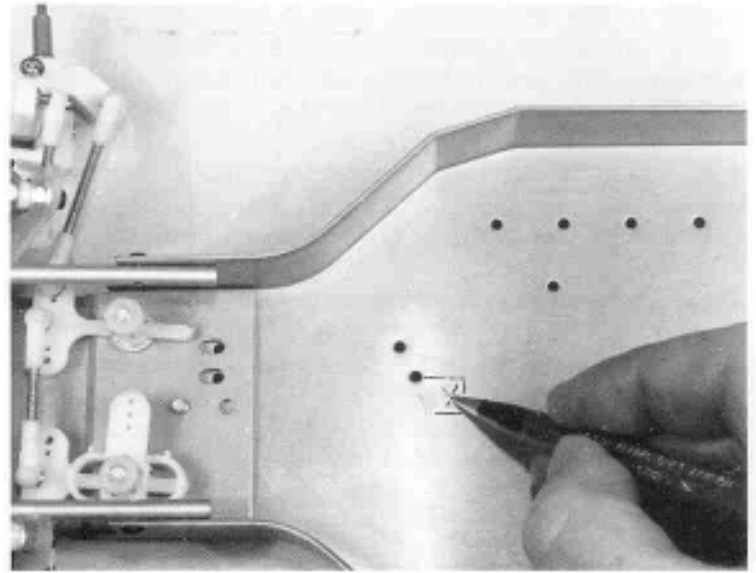

Fig. 154

**-155-** Remove the servo and mark a spot to drill within the outline of the mounting block.



**Fig. 155**

**-156-** Center punch the mark and drill the chassis with a 1/8" (3.1 mm) drill. Countersink the hole on the bottom of the chassis if possible. You can use a large (approx. 3/8") drill and turn it by hand to do the countersinking.

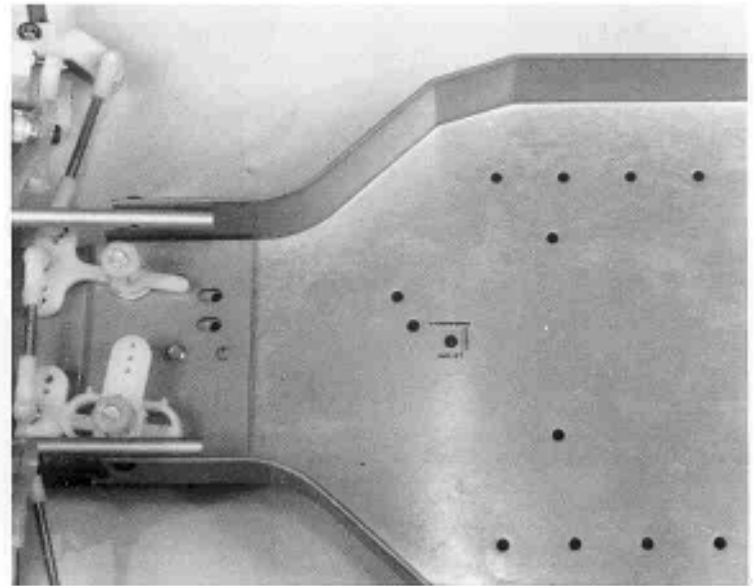

**Fig. 156**

**-157-** Mount the servo and install the linkage following steps 150 and 151. Bend the linkage wire as shown in Photo 157.

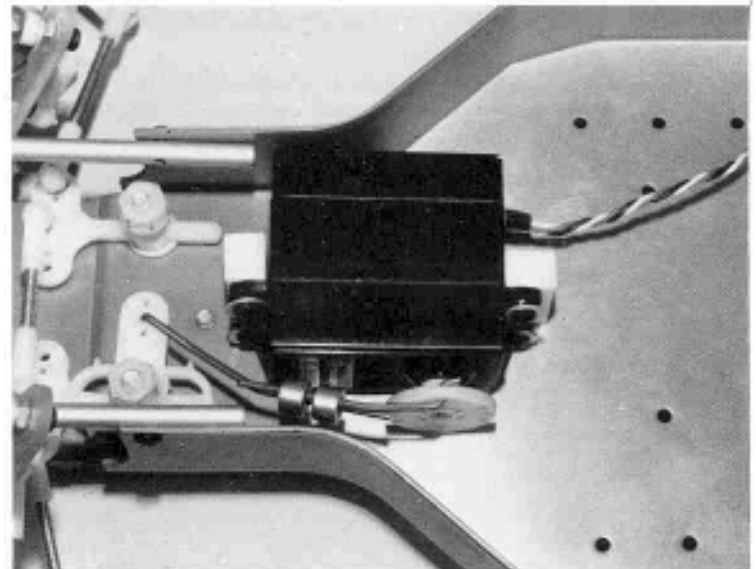

**Fig. 157**

## THROTTLE SERVO

-158- The throttle resistor servo shown here is an S32. Assemble the servo mounts, as you did in step 149, except this servo is placed in the direction shown.

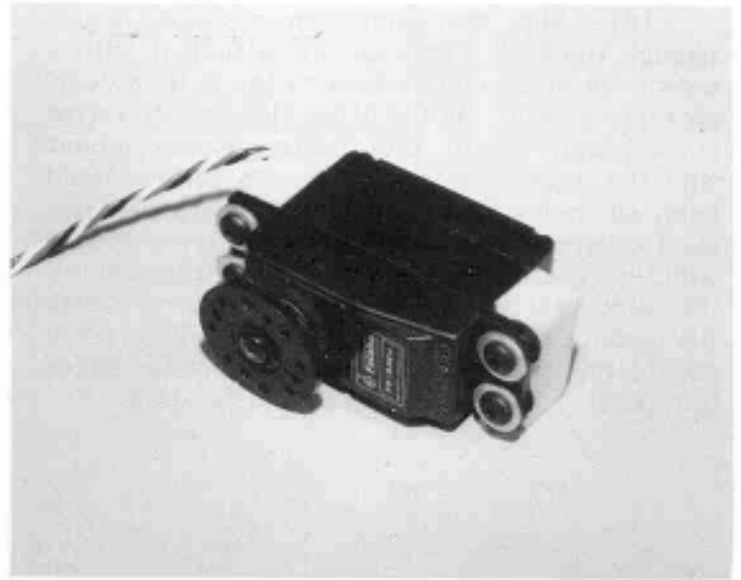

Fig. 158

-159- Install the servo to chassis, as shown. It is important that the servo mount high enough to allow the servo wheel to clear the chassis by about 1/8" (3.1 mm). Add washers under the mounts if necessary to give the required clearance.

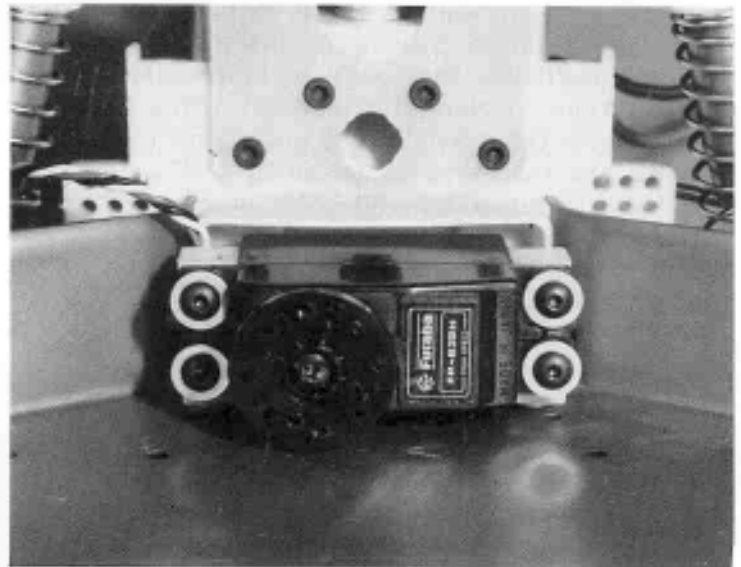

Fig. 159

-160- From bag #613, install the 2 #6713 resistor brackets with 2 flathead Allen screws and locknuts, as shown. Note that the brackets will be turned differently if you are installing a medium or large servo (see special instructions that follow later).

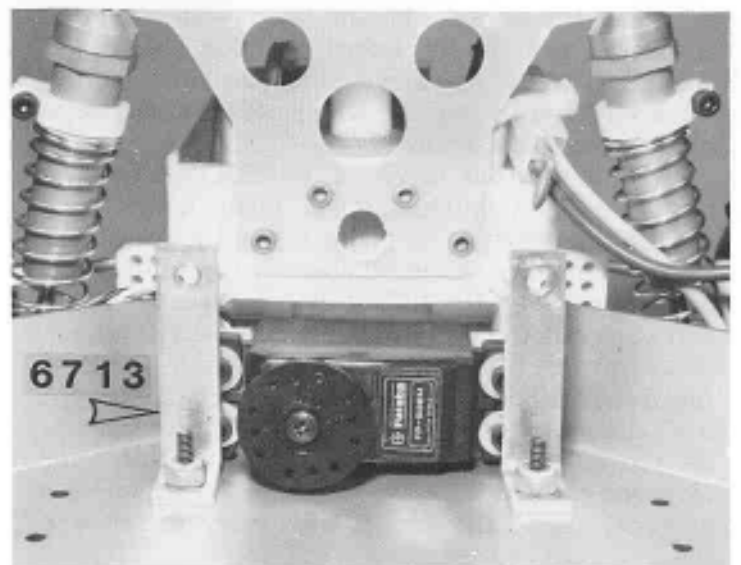

Fig. 160

-161- Slip the aluminum resistor mount through the #6711 resistor and attach it with a short 4-40 screw and locknut to the R.H. side of photo, as shown. On the other side, where arrow is pointing, install the plastic bypass mount with the longest screw going into the recessed hole, as shown with a locknut. There are two plastic bypass mounts. Use the **thicker** mount with the square edges if you are mounting a small (S32) sized servo. For a medium or large servo the resistor brackets must be turned differently and the thinner bypass mount with rounded edges (and possibly dyed a color) should be used.

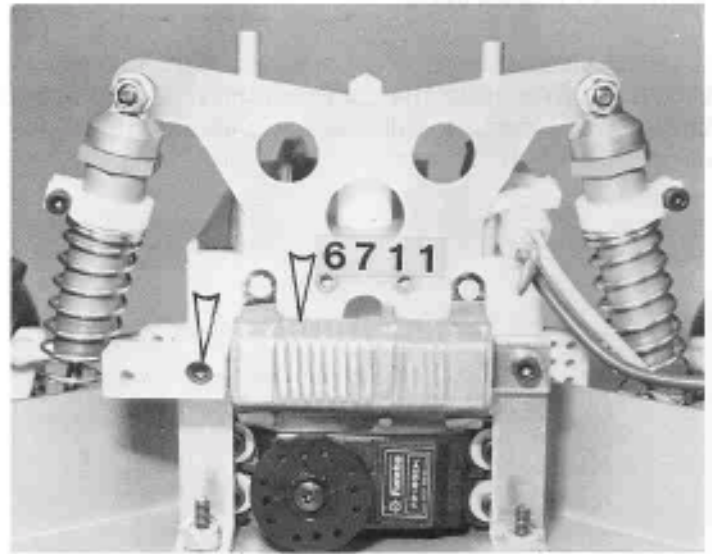

Fig. 161

-162- In the end of these instructions is a full page detailed drawing of the wiring installation. We'll use that page to help clarify the installation. Attach the correct wires to the resistor per the drawing, and make sure the wire lengths are the same as in photo #187. If you put the wires through the holes and bend them around they'll stay while soldering. Use only rosin core solder and solder both connections, as shown. All these wire connections **MUST BE** soldered.

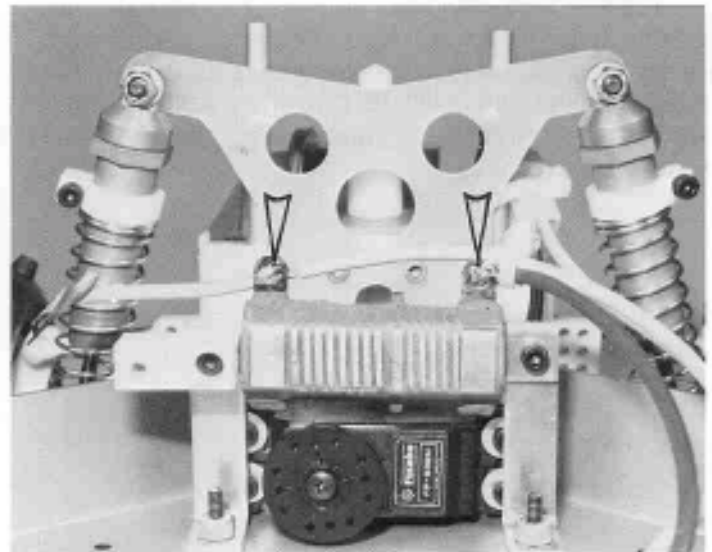

Fig. 162

-163- Center the servo output arm, as before, then turn it about 30 deg to the right of photo. Locate the wiper arm so that it is in the exact location shown and note the closest holes in the servo wheel to mount the wiper. Solder the wire to the resistor in the exact location shown in the photo. Mount the resistor arm to the servo arm in the exact position shown. If your servo wheel has a raised center then use the small washer to stand the wiper off from the edge of the wheel (see Photo 176).

This next item is **VERY IMPORTANT**. The resistor brass button must push quite hard against the resistor to make a good contact. If it does not have enough pressure the motor will not operate to its fullest horsepower and you will burn out the resistor. An easy way to check this is to take the fingernail from your smallest finger and lift the button a very small amount off the resistor. If it lifts off quite easily, it's too soft. It should pull quite hard on your fingernail, **BEFORE** it lifts off - then it's correct. Bend the arm if necessary to achieve this.

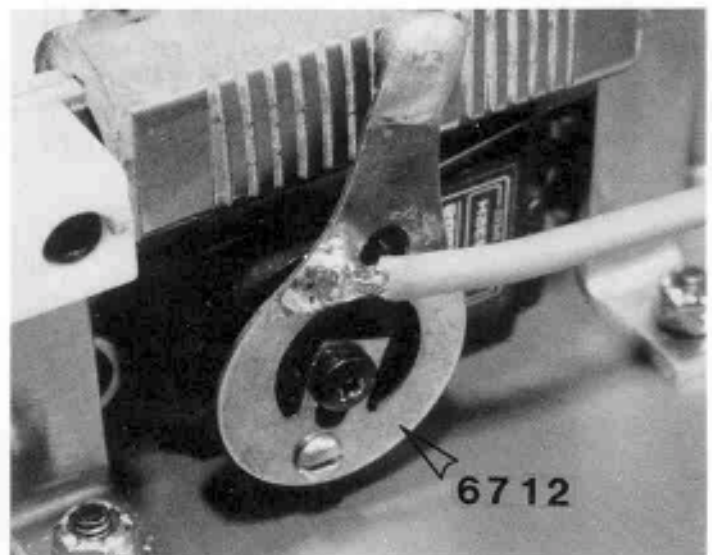

Fig. 163

### Special Instructions — Medium throttle servo

-164- See page 38 for description of servo sizes. Do the following to mount a medium sized throttle servo. Install the servo mounts to the chassis temporarily, using the wider spaced mounting holes.

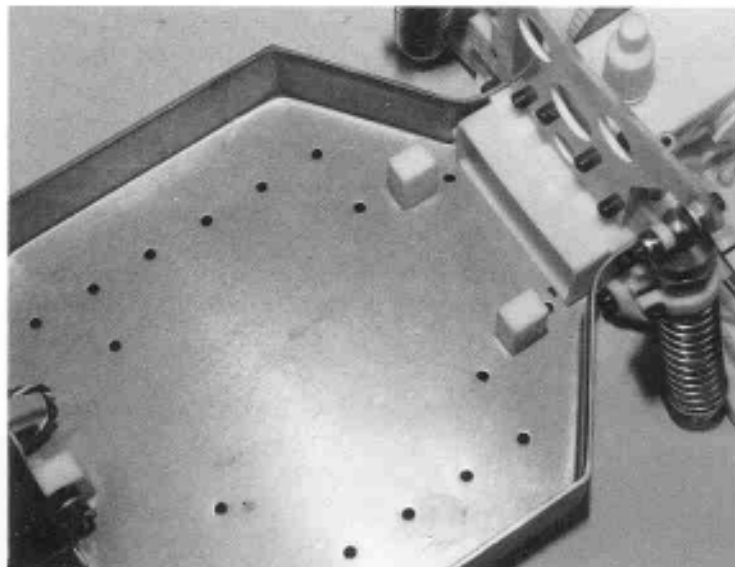

Fig. 164

-165- These are the mounting holes you should use.

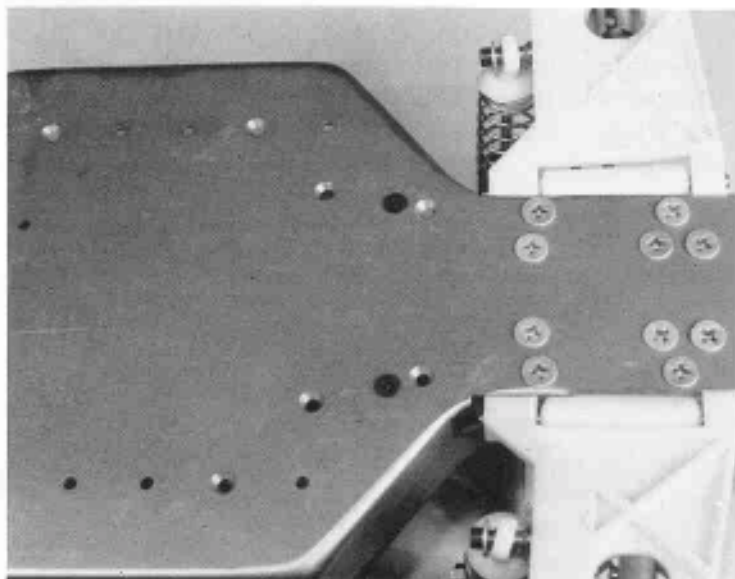

Fig. 165

-166- Drop in the servo and space it off the chassis with a resistor bracket as shown. Mark the servo mounts with a pencil. Remove the mounts from the chassis and drill the mounts as in step 149. Install the mounts to the servo. Make sure the servo is turned so that the output shaft is on the correct side.

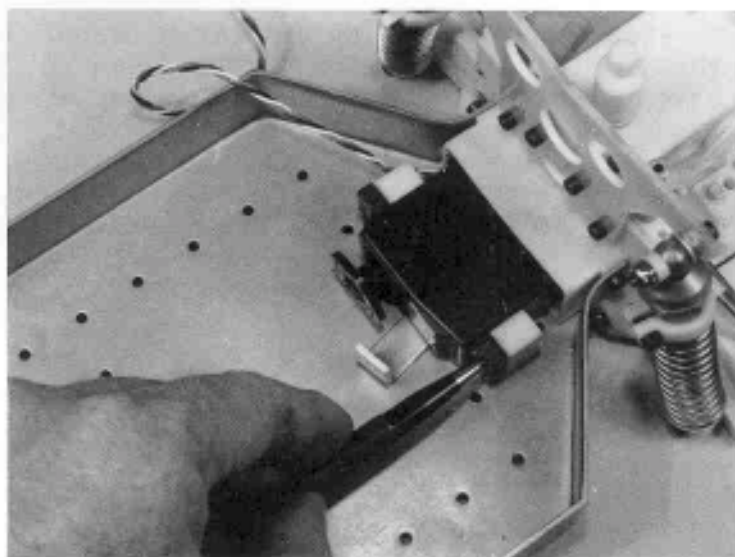

Fig. 166

-167- Install the servo to the chassis as shown. It is important that the servo wheel clear the chassis by about 1/8" (3.1 mm). Use washers under the mounts to achieve the required clearance. Also, some servos (the S28 for instance) are very deep and may bottom out against the bulkhead, making alignment with chassis holes difficult. In this case you should put washers between the mounts and the servo to space the servo away from the bulkhead.

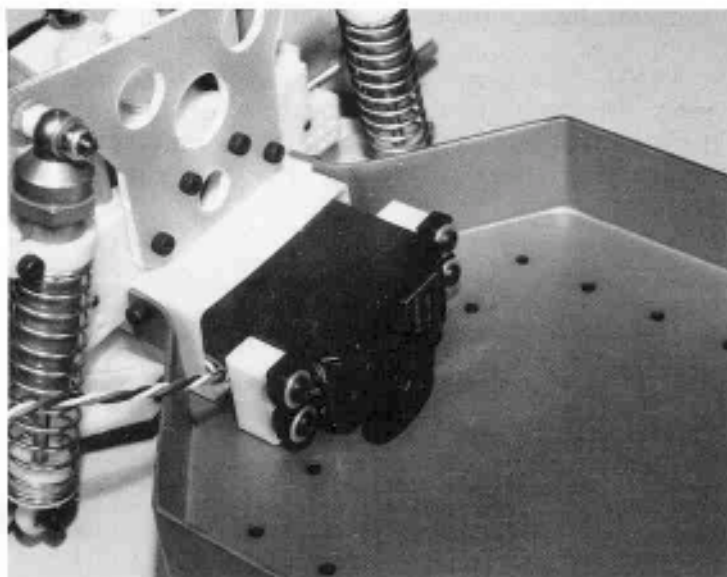

Fig. 167

-168- Follow the first part of step 163 to determine the mounting position for the wiper. Then remove the servo from the chassis and mount the wiper as shown. Reinstall the servo to the chassis.

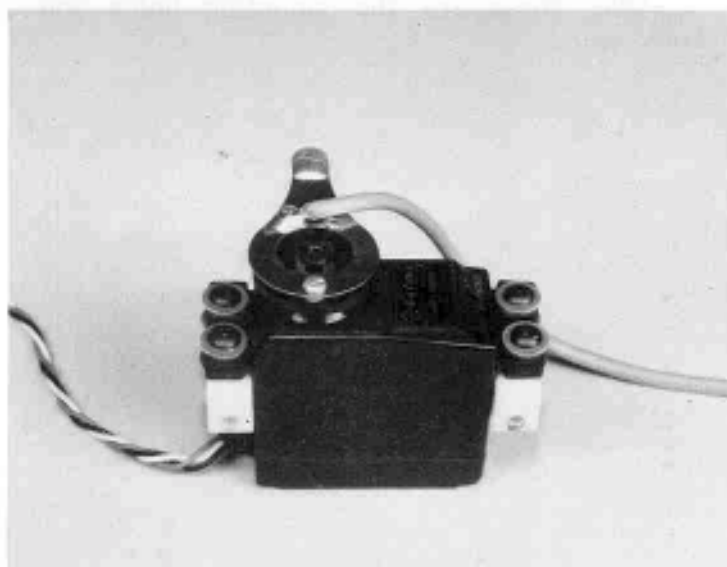

Fig. 168

-169- Follow steps 160 and 161 to install the throttle resistor, but make the following exceptions: the resistor brackets should be turned 180 degrees, so that they look like Fig. 169. Mount the resistor BEHIND the brackets instead of in front; and use the **thin** bypass mount (with the rounded edges). When assembled check for proper wiper pressure as in step 163 and complete the wiring in step 162.

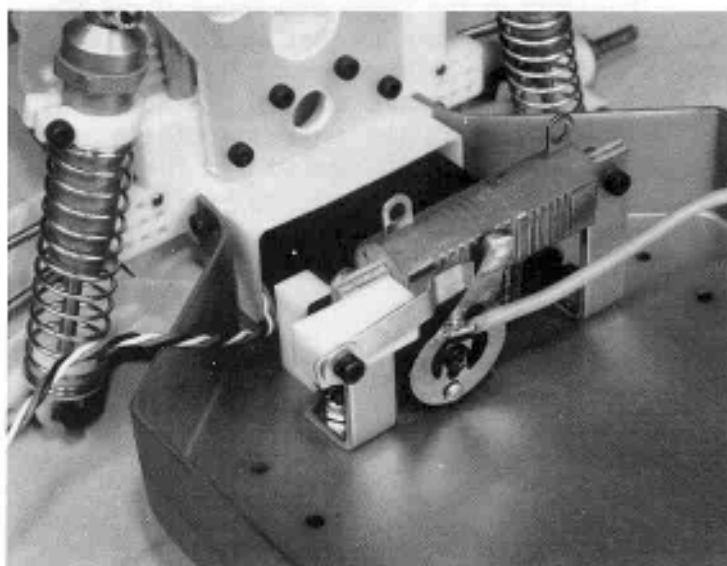

Fig. 169

### Special Instructions

#### — Large throttle servo

-170- It may be necessary to notch the bulkhead to clear the wires for a large servo.

-171- This notch is for a Futaba S27 or S29 servo.

-172- Mark the servo mounts for drilling. Note that the mounts are turned the "wide way" on both sides of the servo (see Fig. 173). Position the servo as high as possible on the mounts before marking.

-173- S27 servo with mounts installed.

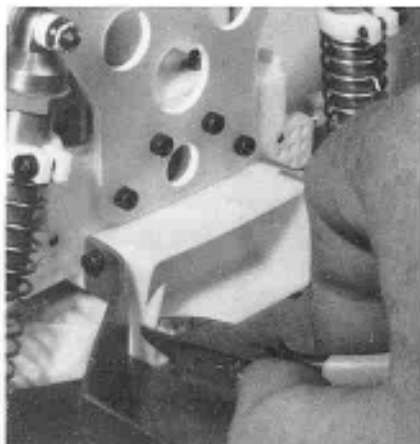

Fig. 170

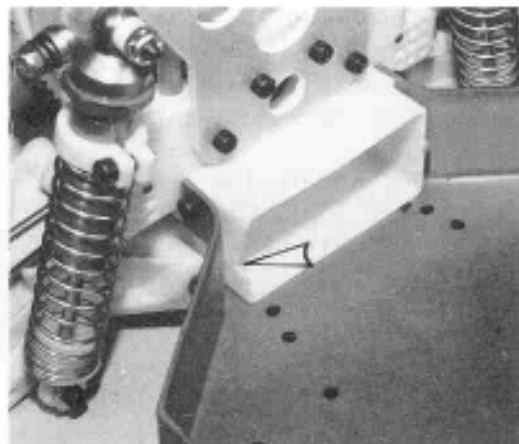

Fig. 171

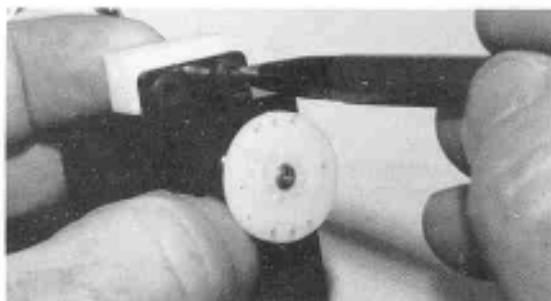

Fig. 172

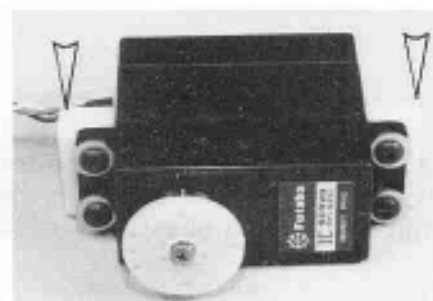

Fig. 173

-174- Position the servo as far back as possible in the chassis and mark the center and edge of the mounts on both sides with a pencil.

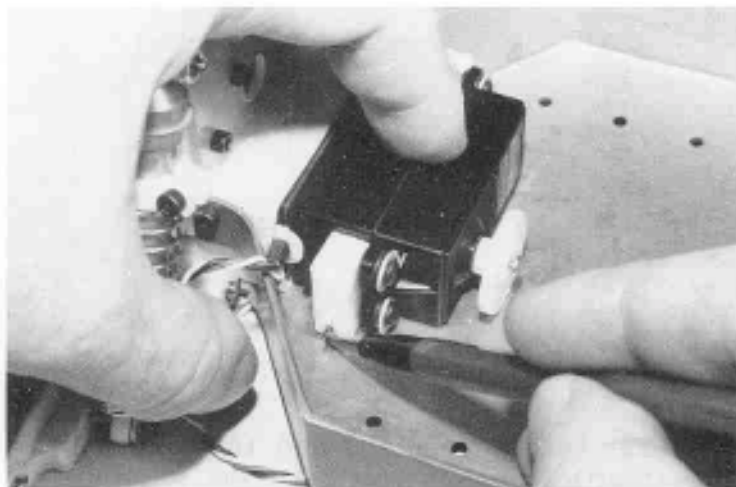

Fig. 174

-175- Locate the positions for the mounting holes by extending the center lines inward. Center-punch, drill and countersink the chassis as explained in step 156.

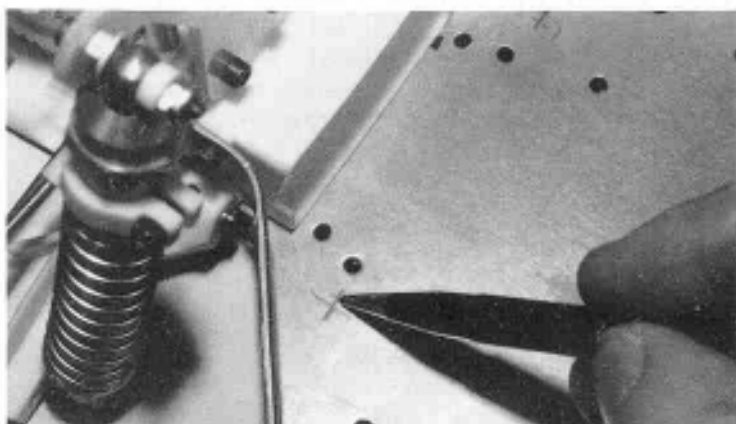

Fig. 175

-176- Follow the first part of step 163 to determine the mounting position of the wiper. Mount the wiper as shown.

-177- Install the servo to the chassis. Mounting holes are typical for S27 servo.

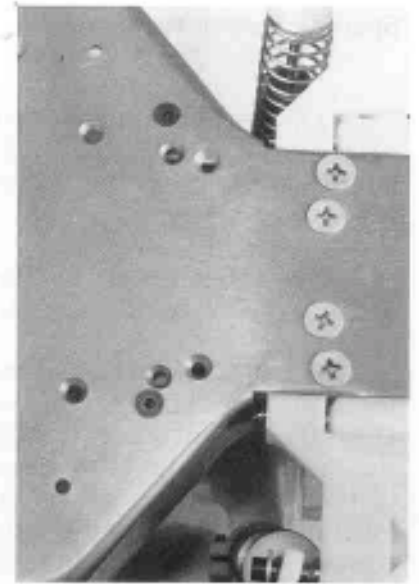
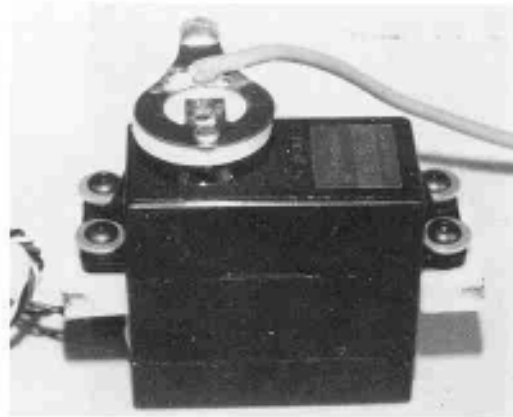

Fig. 177

-178- S27 servo installed. Use spacers under the mounts to make sure the servo wheel and wiper clear the chassis by about 1/8" (3.1 mm).

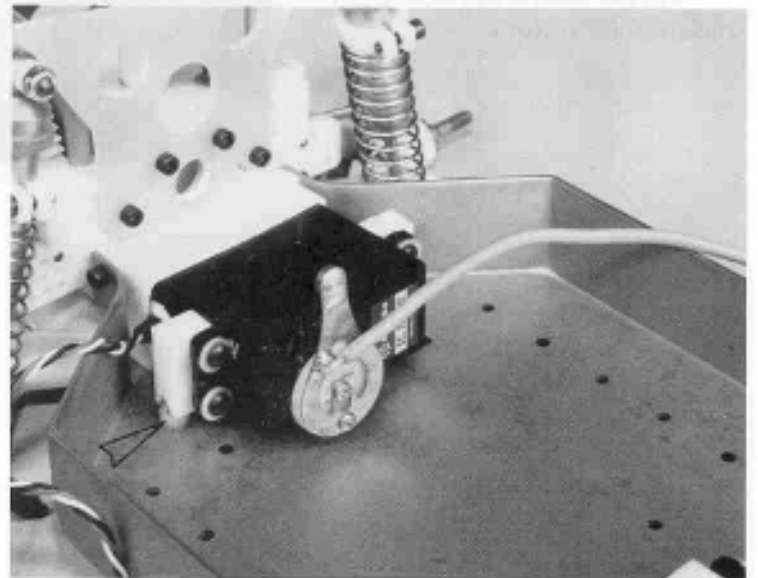

Fig. 178

-179- Follow steps 160 and 161 to install the throttle resistor, but make the following exceptions: the resistor brackets should be turned 180 degrees, so that they look like Fig. 179. Mount the resistor BEHIND the brackets instead of in front; and use the **thin** bypass mount (with the rounded edges). When assembled check for proper wiper pressure as in step 163 and complete the wiring in step 162.

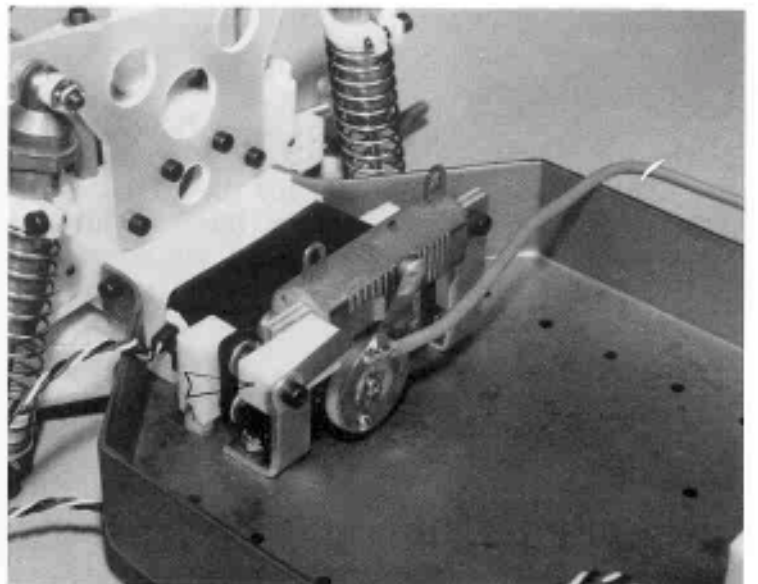

Fig. 179



-180- Large (S27) servo installed.

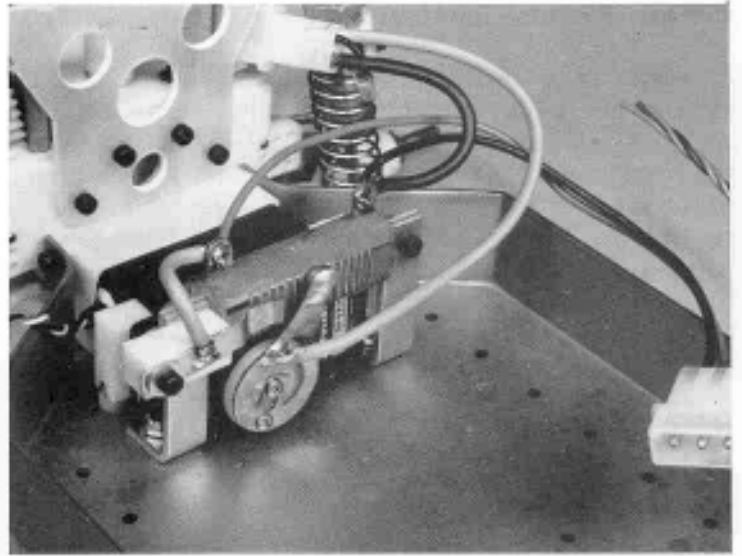

Fig. 180

-181- Medium (S28) servo installed.

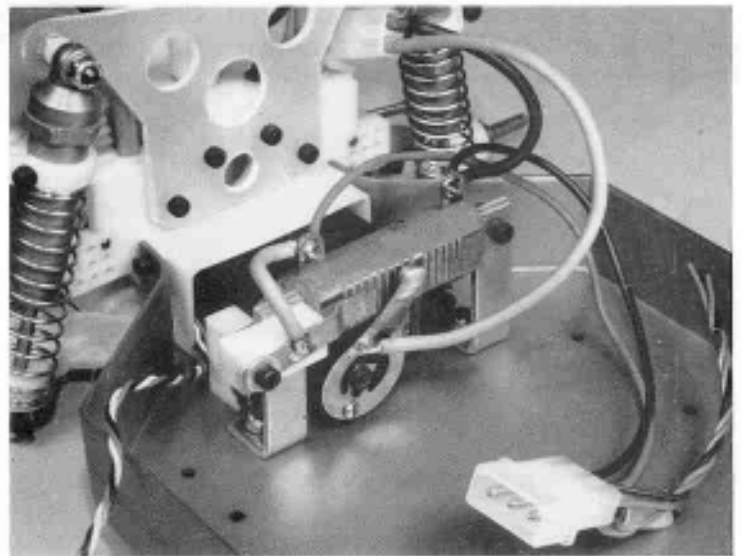

Fig. 181

-182- Small (S32) servo installed.

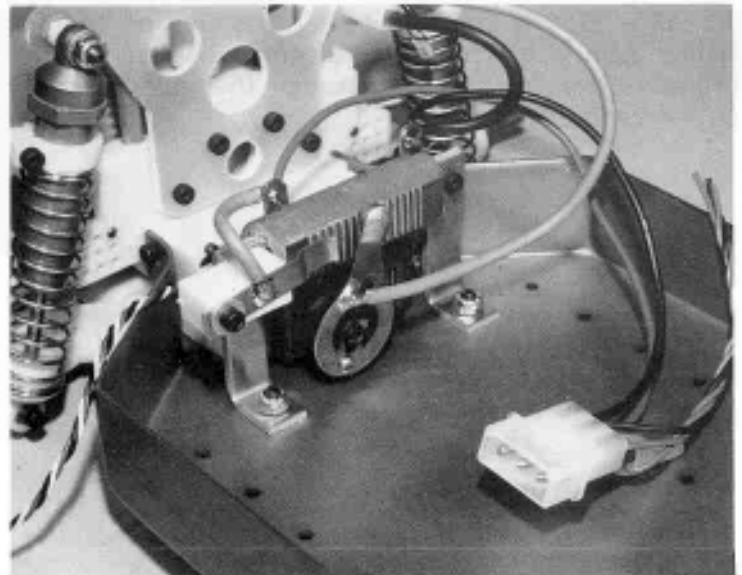

Fig. 182

## FINAL RADIO ADJUSTMENT AND WIRING

-183- Take the bypass and install it to the bypass mount with a 1/2" long Allen screw and washer as shown. Locate the indented portion of the bypass right in the center of the wide band of the resistor. Solder the bypass wire from the resistor to the arm. This photo shows where the wiper arm should be in the off throttle or brake position. On this side of the resistor are the brake bands.

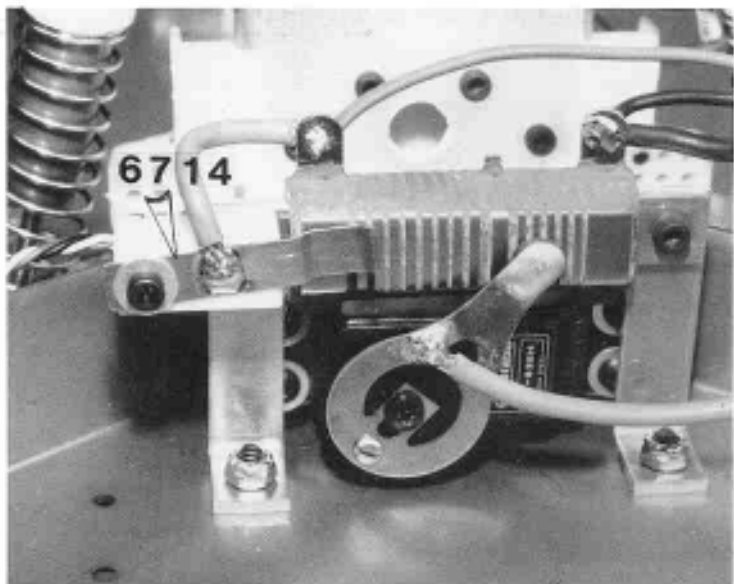

Fig. 183

-184- This is the position that the wiper arm is in at 1/2 throttle. These are the power bands on the resistor.

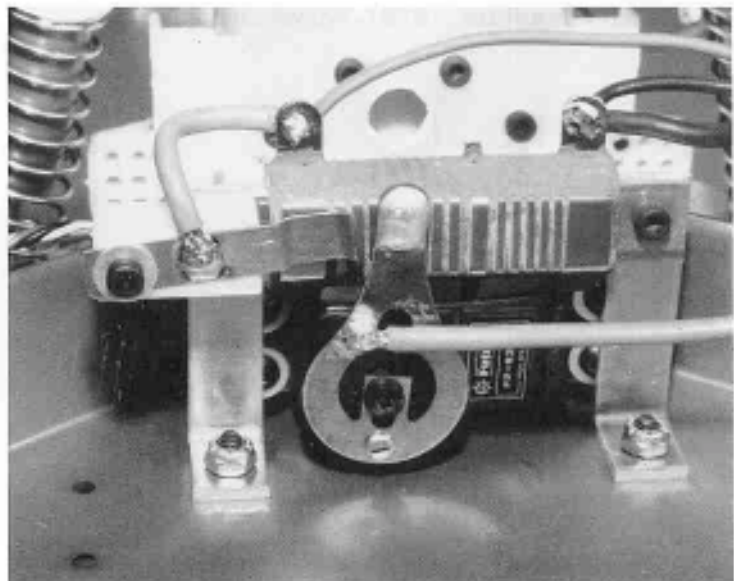

Fig. 184

-185- This is the full power position of the wiper arm. It should be directly behind the bypass button and in the center of the wide band on the resistor.

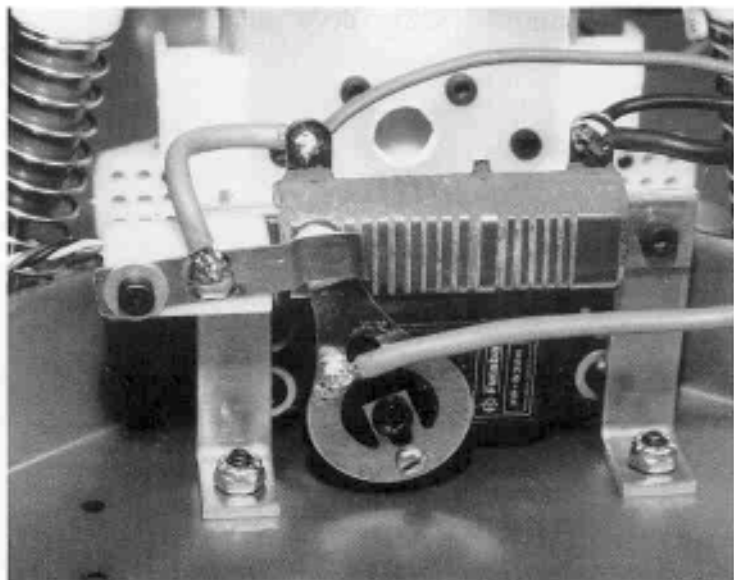

Fig. 185

-186- The arrow is pointing to the space between the bypass button and the resistor band. This distance should be about .025 (.65 mm) less than the thickness of the wiper button section, so that when the wiper arm button moves to full throttle it makes the bypass arm move about .025 (.65 mm) forward. This bypass arm then helps to increase the pressure on the throttle wiper arm button, thereby giving it an excellent electrical connection. This, of course, allows the motor to achieve full horsepower and helps the resistor to last longer.

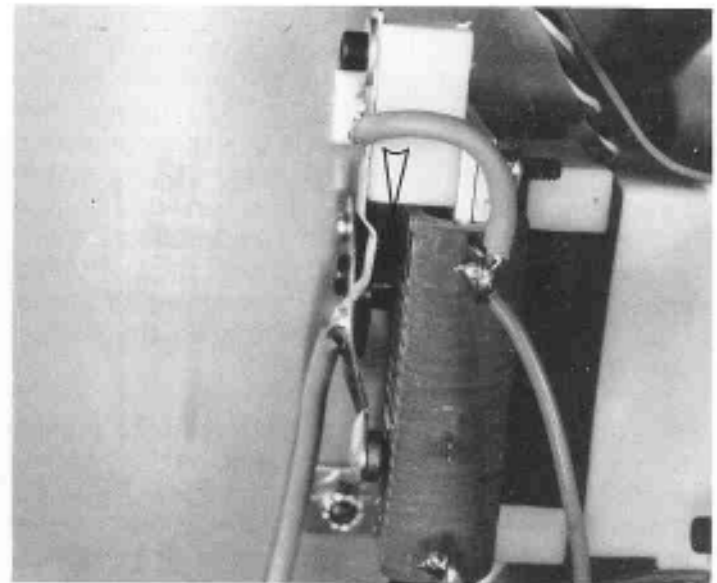

Fig. 186

-187- We've installed the #6745 portion of the wiring, now we'll finish the #6744 wiring. Now, we'll attach the wires to the switch. On the wiring diagram Fig. 216, it shows a black, a green and a red wire going to the radio. You'll only use 2 of these wires, not all 3. On the wiring diagram, you'll notice there are diodes by the battery plug. These diodes cut the voltage down going to your radio so you won't burn out your radio. We'll be attaching 2 of these wires to 2 wires on the radio switch. If there's short wires on the switch, use these for the connections. You'll have to cut the connector off and strip the end of the wires about 1/4" for soldering. We'll tell you the correct wiring for different radio and battery combinations. With a Futaba radio and a 6 cell battery pack - solder the black (-) lead, on the diagram, to the black (-) lead, on the switch. Then solder the green (+) lead on the diagram to the red (+) lead on the switch. Cut the extra red wire off by the 3 pin connector. With a Futaba radio and a 7 cell battery pack, solder the 2 black ends together, and then solder the 2 red ends together. Cut the green wire off by the diode. With an Airtronics radio and a 6 cell battery pack solder the black (-) lead, on the diagram, to the #2 (-) which is marked on the switch plug. Now solder the green (+) lead on the diagram to the #3 (+) lead. Cut the extra red wire off by the 3 pin connector. With an Airtronics radio a 7 cell pack - solder the black (-) lead, on the diagram, to the #2 (-) wire. Now solder the red (+) lead to the #3(+) wire. Cut the extra green wire off by the diode. For other radios you'll always solder the black (-) wire to the (-) wire on your switch. With a 6 cell battery pack you'll solder the green (+) wire to the (+) wire on your switch and with a 7 cell pack you'll solder the red (+) wire to the (+) wire on your switch. Now, with black electrical tape, put a few wraps of tape around the first solder connection, and then put a few wraps around the 2nd solder connection. Now, attach the #6334 battery trays to the chassis, from bag #67, as shown, with the flathead Allen screws.

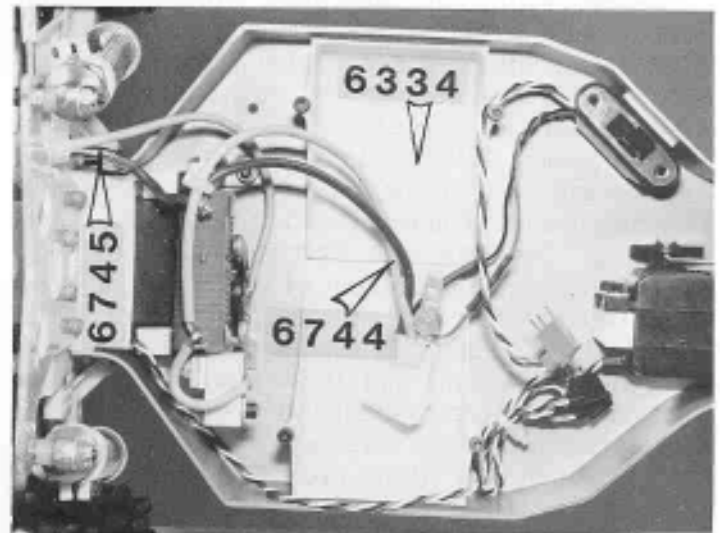

Fig. 187

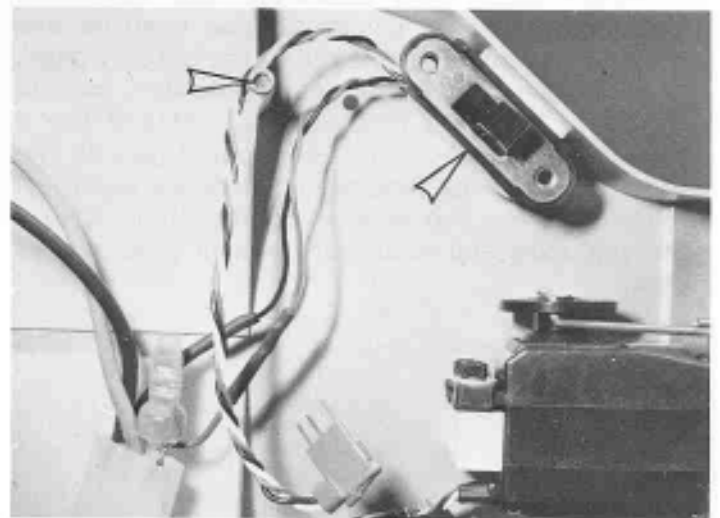

Fig. 188

-188- In bag #67 are 2 Allen screws with cross drilled holes in the heads. Install these in the 2 forward holes in the battery trays, where the arrow is pointing. Do not tighten the screws all the way down, but leave them up about .025 (65 mm). Then in the other 2 rear holes install the other 2 regular Allen screws. Do not tighten these all the way either, but leave them up about .080 (2 mm). Now, attach the switch to the side of the chassis, as shown, with servo tape. Mount the switch down low so the toggle doesn't hit the body.

-189- There should be enough room to mount the receiver between the servo and battery trays, as shown. Put about 4 layers of servo tape on the bottom of the receiver and stick it to the chassis. If you have a bigger servo or receiver, stand the receiver on its side and mount it.

-190- Install the wire plug from the switch into the battery socket in your receiver. Install the steering servo plug into the proper socket and then install the throttle servo plug into the proper socket per your radios instruction manual. Take the long plastic antenna tube and install it into the large hole in the #6338 antenna mount. The round end of the mount is the bottom. The tube will fit tight, but it will go in. Now, from the bottom of the tube, feed the receiver antenna wire up through the tube, from the bottom. Push the wire up through the top about 1" (25 mm) and tie a knot in it. Now attach the antenna mount in the location shown. Any excess antenna wire can be stowed by the mount, as shown. There are a few extra holes in the bottom of the chassis which will not be used. Cover these holes, from the top, with cellophane tape or the servo tape and this will help to keep the dirt out of the car.

-191- Now we'll assemble the batteries. You'll notice there should be one positive and one negative end on each end of the battery pack. There is also a battery assembly drawing page in the back of these instructions. Attach the 2 battery sticks together with servo tape, as the photo shows so the tabs can be soldered together. If the tabs are too short, connect them with a piece of wire and rosin core solder together, as shown.

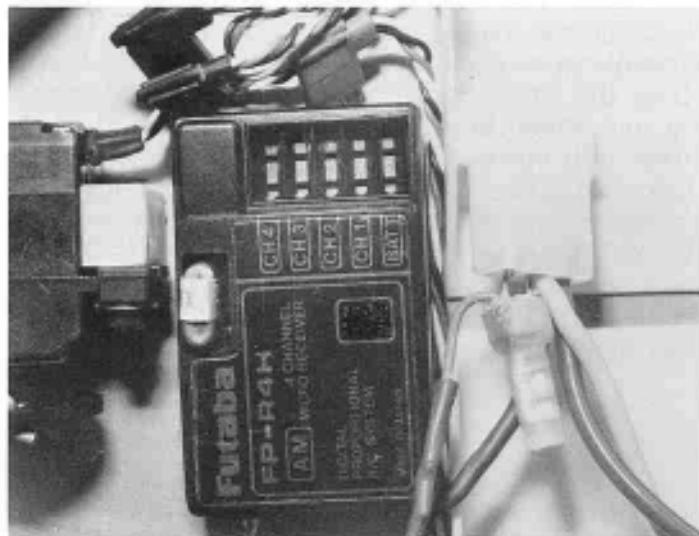

Fig. 189

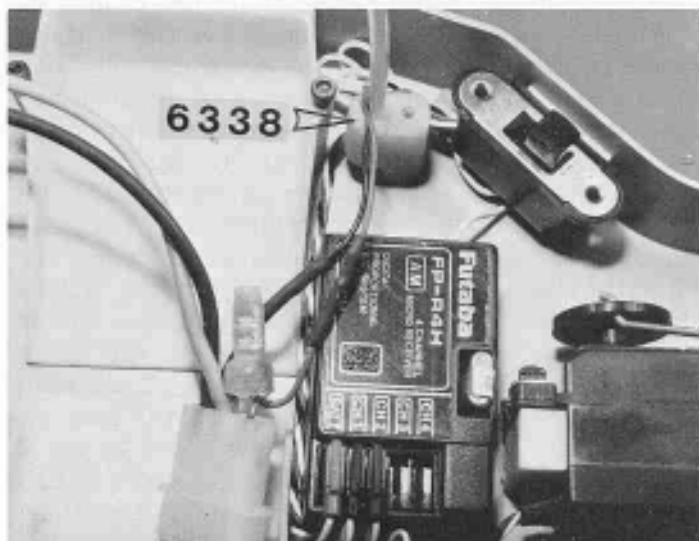

Fig. 190

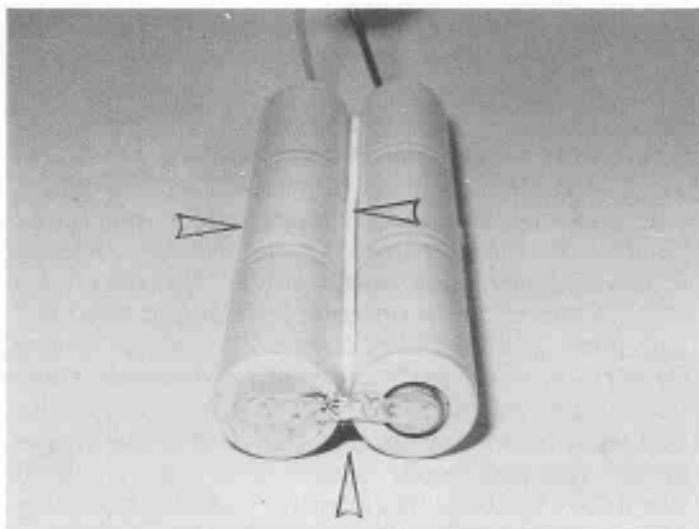

Fig. 191

-192- In this photo, the arrow is pointing to the negative side. Solder the black wire to this tab, as shown.

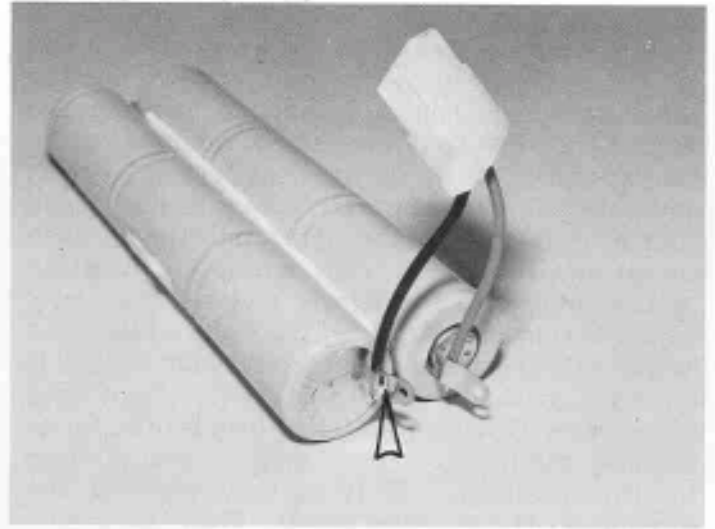

Fig. 192

-193- In this photo, the arrow is pointing to the positive end. Solder the red wire to this tab and then bend the tabs back flush as close as possible.

-194- Now wrap both ends of the battery with strapping tape or black electrical tape, as shown.



Fig. 193

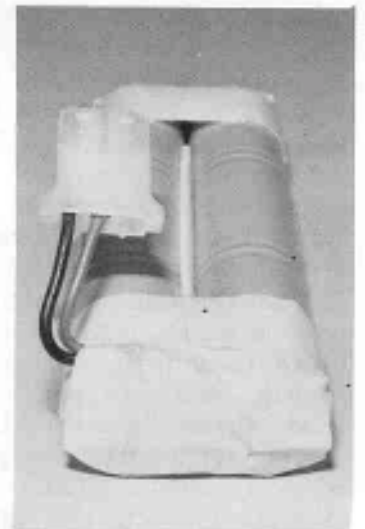

Fig. 194

-195- In bag 8/6 is the #3736 battery charge cord. We'll have to solder the ends to the wires. The arrows, in the photo, are pointing to the positive (+) connection. This is the silver appearing wire, not the black wire. There is a clear plastic coating on this wire, which is very hard to see. Take your Xacto knife and scrap off this clear coating on the end for soldering. Slip the red tube on the wire. Now solder the wire to the clip as shown. If you have a small soldering iron, you'll have to hold it on awhile longer to heat up the clip. Now solder the black negative (-) wire to the other clip using the black tube. In the back of these instructions is a page on charging batteries. Read it carefully and charge the battery pack. Also make sure the batteries in your radio transmitter are charged.

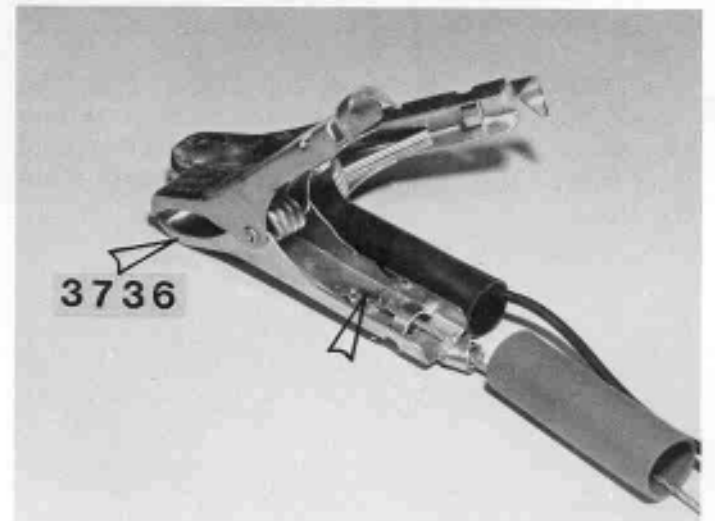

Fig. 195

**-196-** Slip the charged batteries into the radio tray, as shown. In bag #67 are the 2 battery straps and 4 clips. Slip the keyhole end of the straps, over the rear screws in the battery trays. Then pull them forward so the slotted end slips under the screw head. Slip the forward end of the straps over the forward screws and put 2 clips through the screw heads. Take your charged radio transmitter, pull the antenna up and turn the transmitter switch on. Plug the battery plug into the wiring plug as the arrow shows. If your servos moved then your switch was in the "ON" position. Make sure your switch is correctly marked "OFF" and "ON". Turn your switch on for ONE SECOND and turn it off. Refer to photo #183. See if your resistor arm is close to this position. If it is not, unscrew the wiper arm off the servo wheel. Turn the switch on. Advance the throttle arm on the transmitter. See if the servo arm rotates in the proper direction. If it doesn't, turn the car switch off and transmitter off. Refer to your radio instructions and reverse the throttle servo. Now, turn the transmitter on and the car switch on - does the servo rotate in the correct direction now? O.K. Then release the throttle. Turn the car switch and transmitter off.

Install the wiper arm on the servo arm in the exact location shown in photo #183. Turn the transmitter on and the car switch on. The wiper arm should now be exactly like in photo #183. Pull the throttle half way. The wiper arm should now be close to photo #184. Pull the throttle all the way open. The wiper arm now should be exactly as shown in photo #185. This can be accomplished by setting the end point adjustment on your transmitter per your radio manual. Now refer to photo #151. Turn your transmitter steering wheel to the right. Your wheels should turn to the right. If not, you'll have to reverse the steering servo, as before. Now you'll want to get the #6256 linkage centered, as shown. You may have to change the hole location on the servo wheel.

**-197-** Turn the car switch OFF. Plug the motor plug into the wiring socket, as shown, then tie a small tie wrap around the wiring socket and wing tube. This will keep the wires away from the tires.

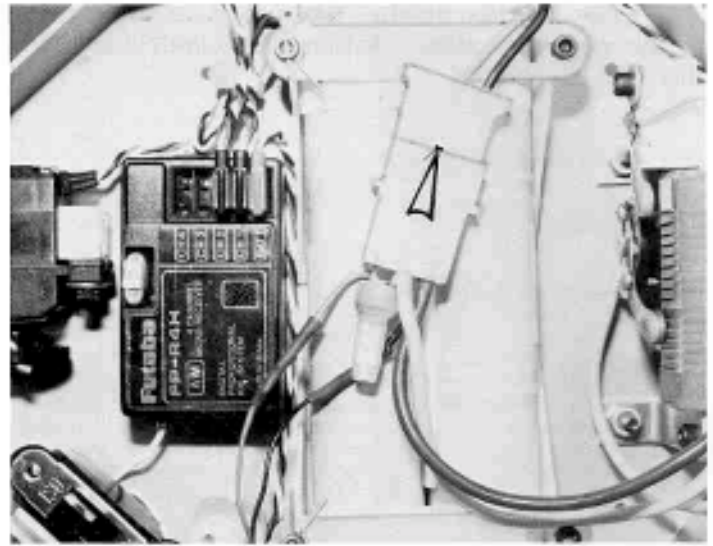

Fig. 196

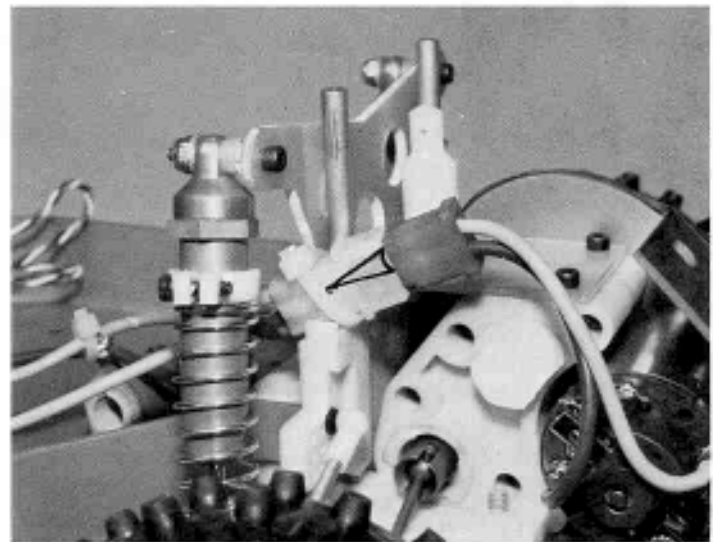
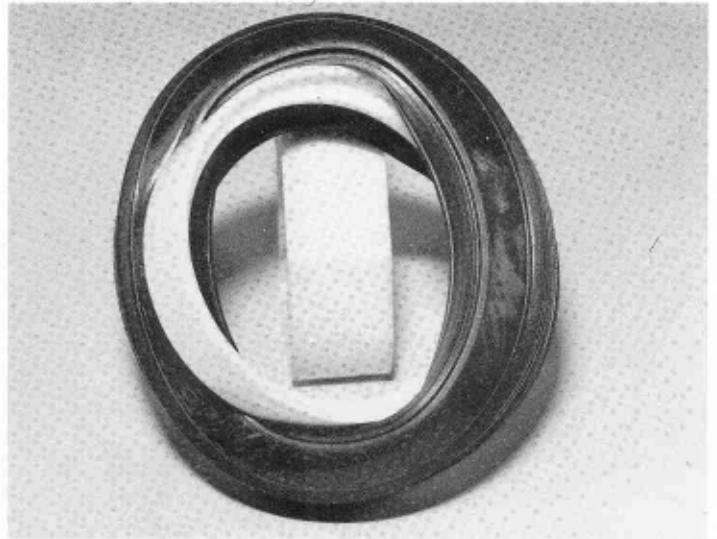

Fig. 197

**-198-** Take the front wheels and tires out of the bag. We want to put the large plastic ring inside the tire as shown.



**Fig. 198**

**-199-** The #6865 front tire, with the ring inside.

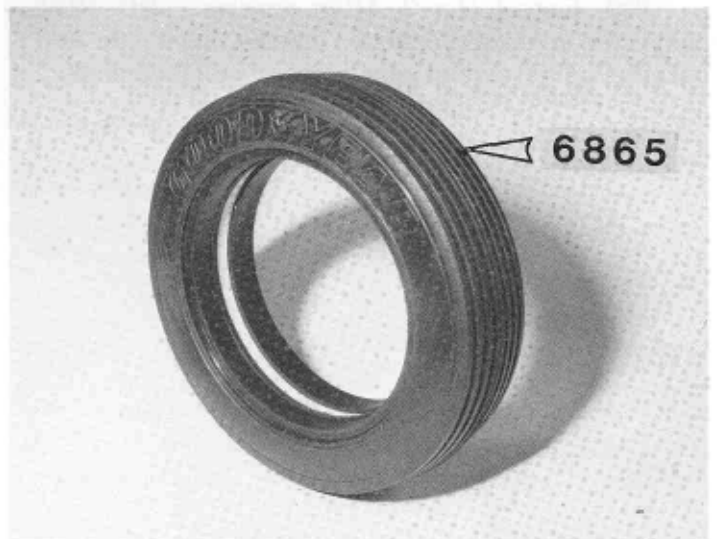

**Fig. 199**

**-200-** Take the outside half of the #6850 front wheel, as shown, and push it into the front tire making sure it is seated all the way around.

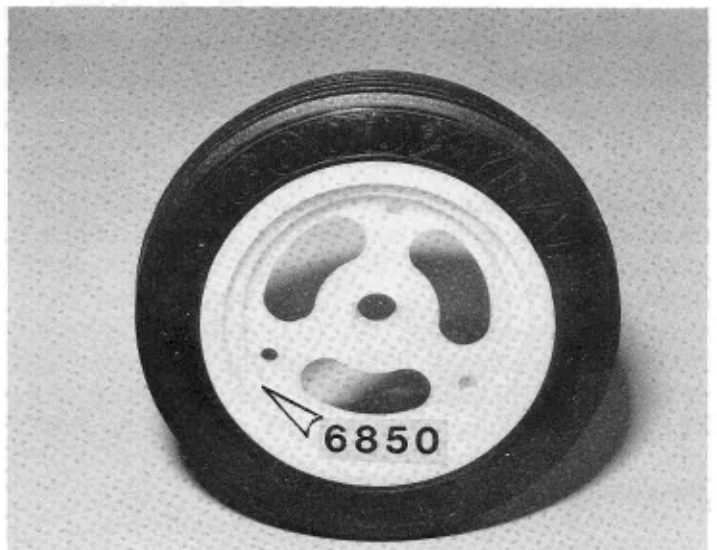

**Fig. 200**

**-201-** turn the tire over and install the inside half of the wheel. Make sure the screw holes are in line.

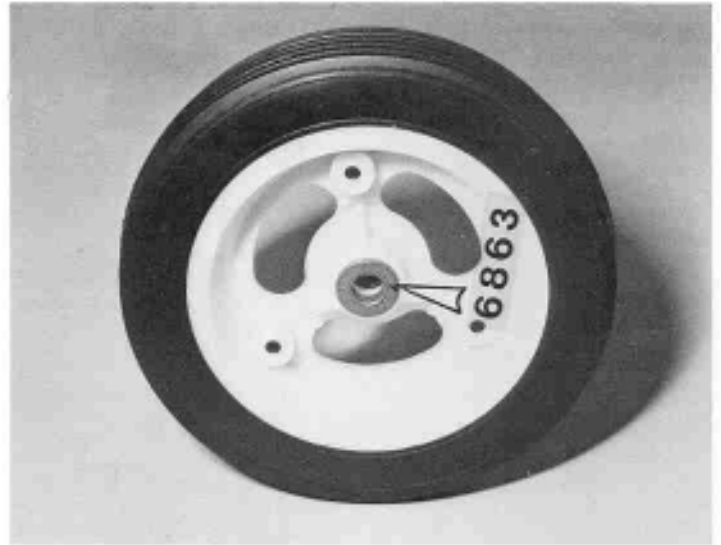

Fig. 201

**-202-** Install the 3 Allen screws. DO NOT overtighten these screws. Install the inside and outside #6863 wheel bushings or ball bearings.



Fig. 202

**-203-** Oil the bushings and slip the wheels on the front axles. Spin the wheels. They should spin true. If not, re-mount the tires. Then install the steel flat washer and the locknut on each wheel. Included in the front wheel bag is a small bag with 4 small plastic ball bearing adaptors. These will fit inside the Tamiya Rough Rider front wheels and tires #119, allowing you to use these tires on your car. These tires will wear a little faster than the tires on your car now, but they will also give a little more traction, which might be necessary on some tracks. Another hint, which will keep the dirt from sticking between the wheel and tire rim, is to run a small bead of ZAP adhesive on the outside of the tire by the wheel.



Fig. 203



**-204-** Take the rear tires #6815 and slip the wide plastic rings inside the tires.

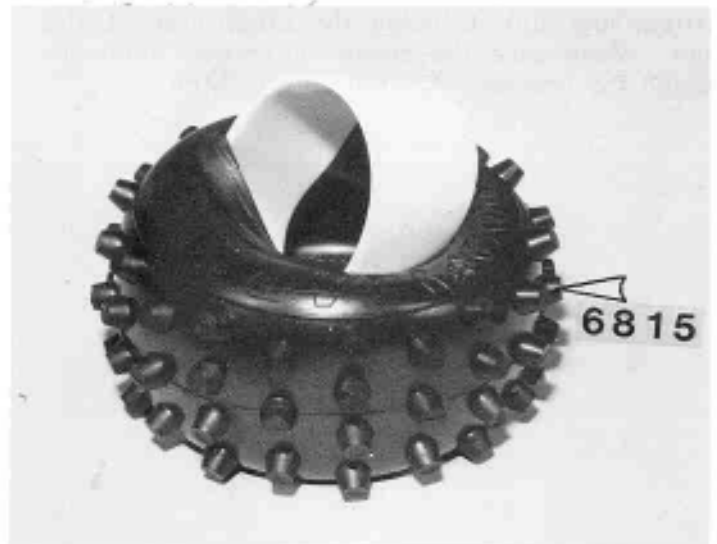

Fig. 204

**-205-** They then should look like this.

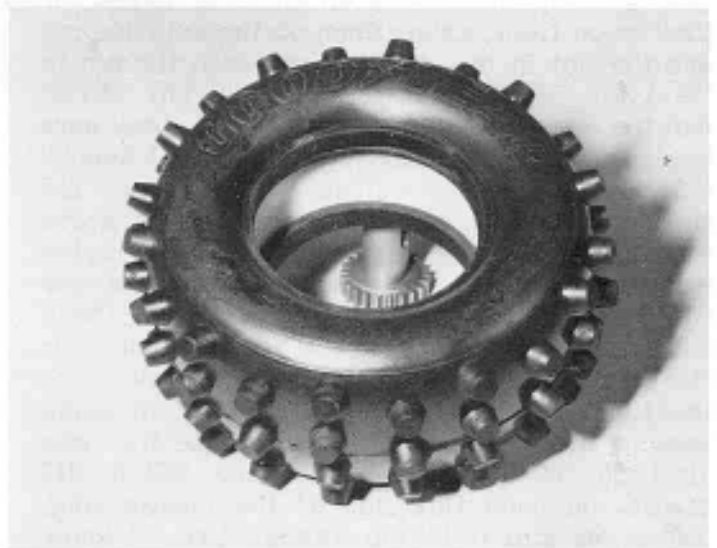

Fig. 205

**-206-** Take the inside half of the wheel and slip it inside the inside side of the tire, as shown.

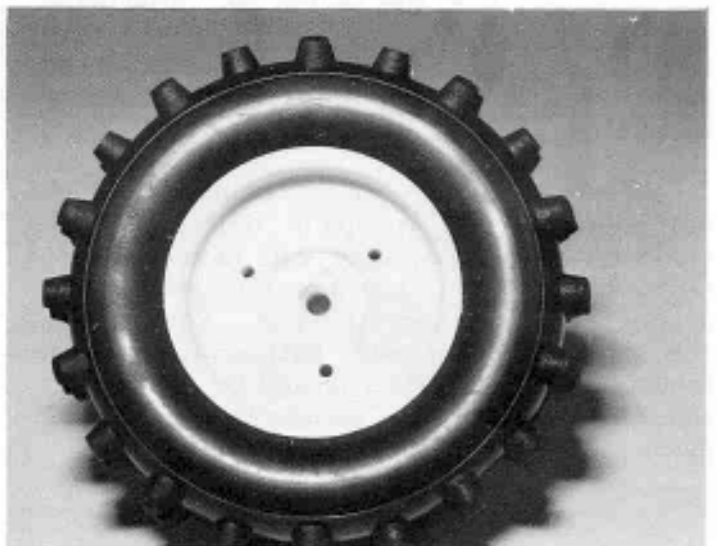

Fig. 206

-207- Now take the outside half of the #6800 wheel and slip it inside the other side of the tire. Make sure the screw holes are lined up. Install the screws. Do not overtighten.



Fig. 207

-208- Slip the wheels on the rear axles. If they go on tight, screw them on the axle making sure the slot in the wheel aligns with the pin in the axle. Screw the nylon wing nut on. NOTE that the wing nuts in newer kits have three ears instead of two, and look more like real knock-offs. These nuts, as well as matching nuts for the front wheels, are contained in a separate bag. Also (back in the wheel bag) are 2 nylon rings which can be used to mount the Tamiya rear Off Roader #153 tires on your wheels. These tires will wear quite a bit faster than your stock kit tires, but they will also give you more traction, which could be necessary on some tracks. Another hint, which will make the tires air-tight, is to use a dab of the #6336 diff grease, on each flat side of the plastic ring, before you slip it in the Tamiya tire. I know you can't wait to see if the car runs, so turn the transmitter on, hold the car up by the center of the chassis, with your hands away from the rear tires, and turn the switch on. Touch the throttle just a little way and see if the tires turn forward. If everything's O.K., go ahead and play with the car a little while, but be careful!



Fig. 208

-209- The driver can be painted to look quite life-like. If you paint the helmet and visor on the inside, they will have a glossy appearance. Then if you paint the rest on the outside, it will be very life-like. You can use the small brush on paint bottles available in hobby stores. The driver should be trimmed as shown, then it will slide up into the body, and 2 pieces of tape will hold it in place.

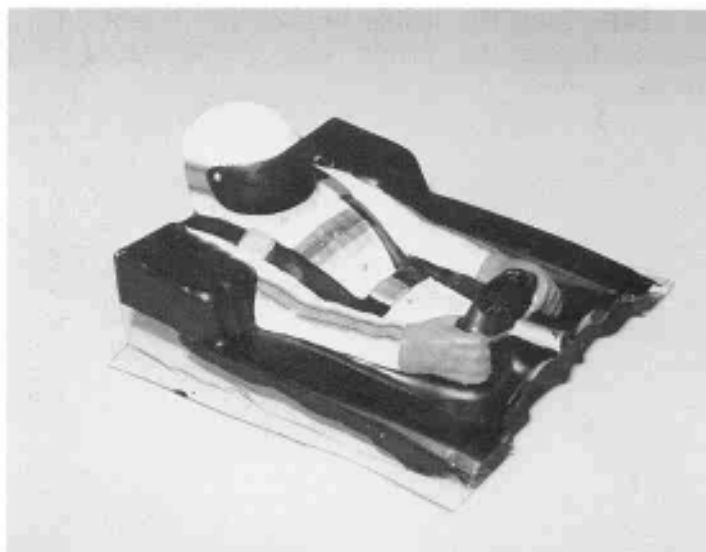

Fig. 209

-210- The body can be painted before you mount it, however it might be easier for you to mount it while it's clear because it will be easier to locate the holes for the body mounts and wing tubes. This photo shows the trim lines for the front of the body and the front body mount hole.

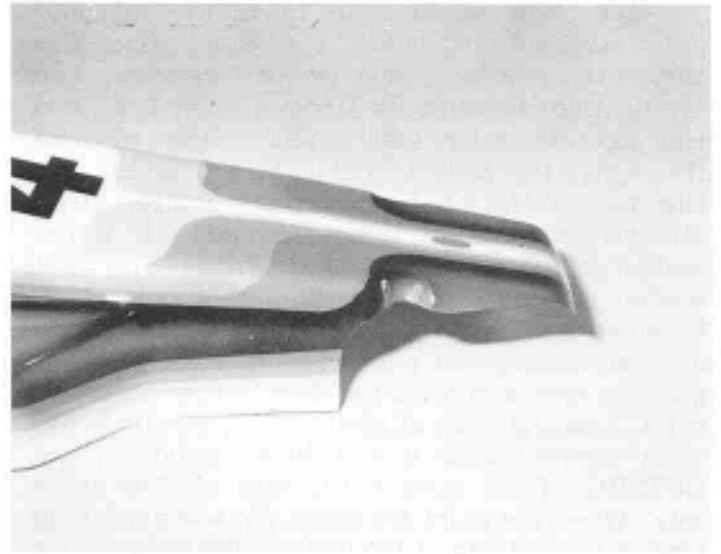

Fig. 210

-211- The rear of the body must be trimmed like this to clear the shocks.  
NOTE: Save the trimmings to use for testing paint.

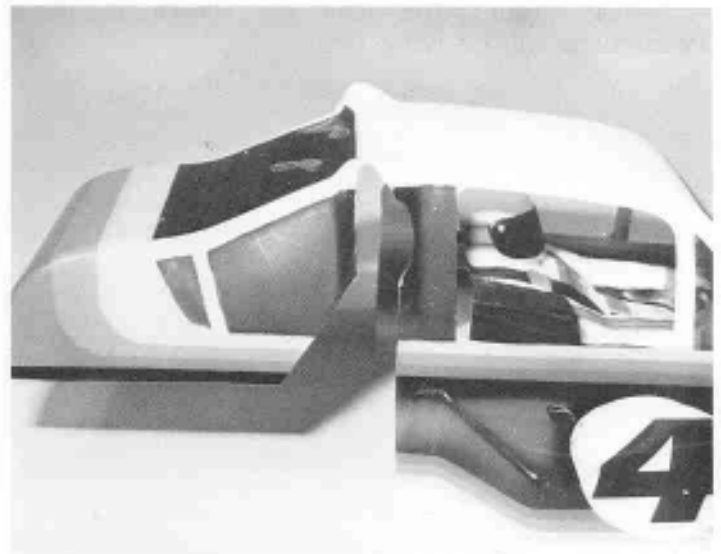

Fig. 211

-212- Trim a little of the body and slip it on. Keep trimming a little at a time until it clears the shocks. Cut out the body mount hole and the 2 wing tube holes. When you've got the body fitted, it's time to paint the body and wing. The body is painted on the inside and the wing is painted on the underside. There are 2 different ways to paint the body. By either brushing it on or spraying it on. The body is made of Lexan polycarbonate. In hobby shops, you can find special Lexan or polycarbonate paints made for these type bodies, to brush on. Do not use any other type brush-on paints. If you want to spray it on, the easiest way is to go to an automotive supply store and buy the small spray cans of "Touch-Up" paint. These will come in any color you want. Dupli-Color is one brand name. BE SURE to test the paint on a piece of trimming from the body. If it warps the plastic or fails to stick then try another brand or type of paint.

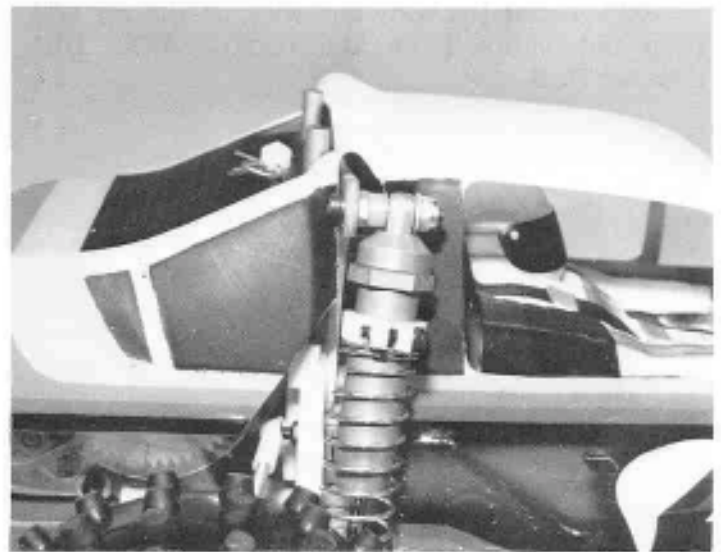

Fig. 212

-213- Now you'll have to figure out your paint scheme and mask the body off. Use automotive masking tape for best results. You always want to paint the darkest color first, and the lightest color last. So, in the case of this wing, the darkest color, which is towards the top of the photo, would be painted first. This means the first thing you mask off is the section which will be painted white. The next section you mask off is the lightest color next to white and so on. After you've painted the darkest color, you peel off the next layer of masking tape and paint the next lighter color and so on. Looking back at photo #212, this body has been painted with a flat black paint on the OUTSIDE of the body in the rear window areas only. When you paint the body, put some masking tape on the outside of the body at the body mount holes and wing tube holes and at the shock cutout holes so the excess spray does not get on the outside of the body.

-214- Mount the wing as shown in the instructions in the wing bag.

-215- Mount the body and wing on the car and then pat yourself on the back. YOU DID FANTASTIC!!

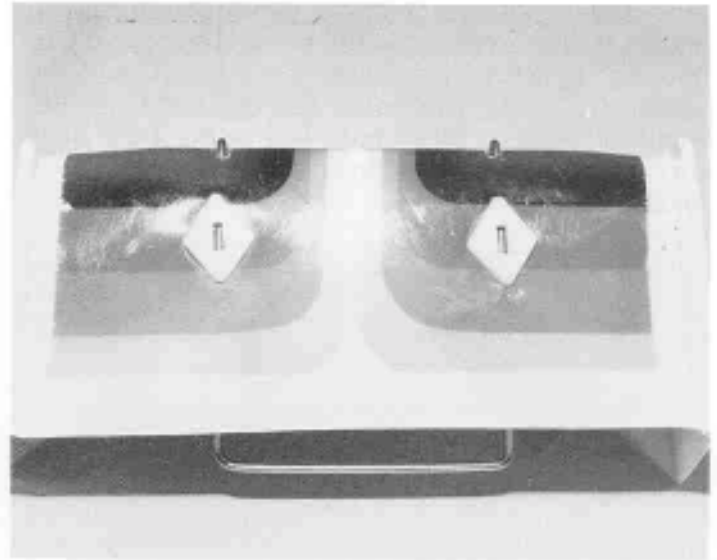

Fig. 213

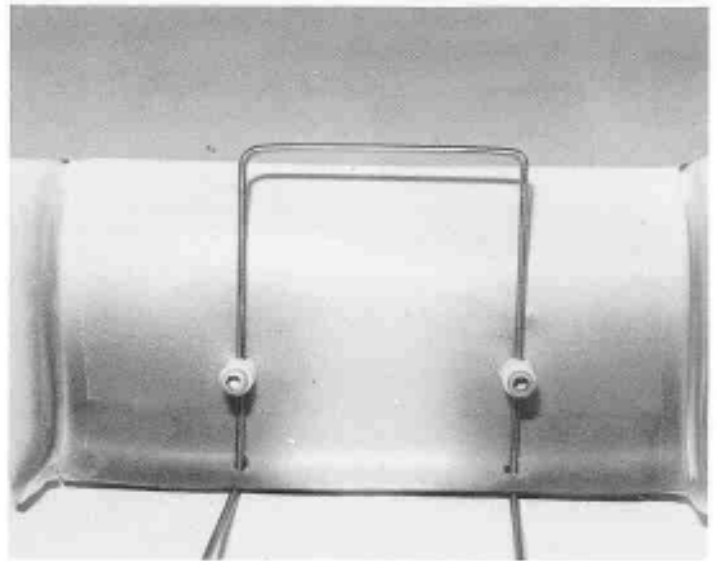
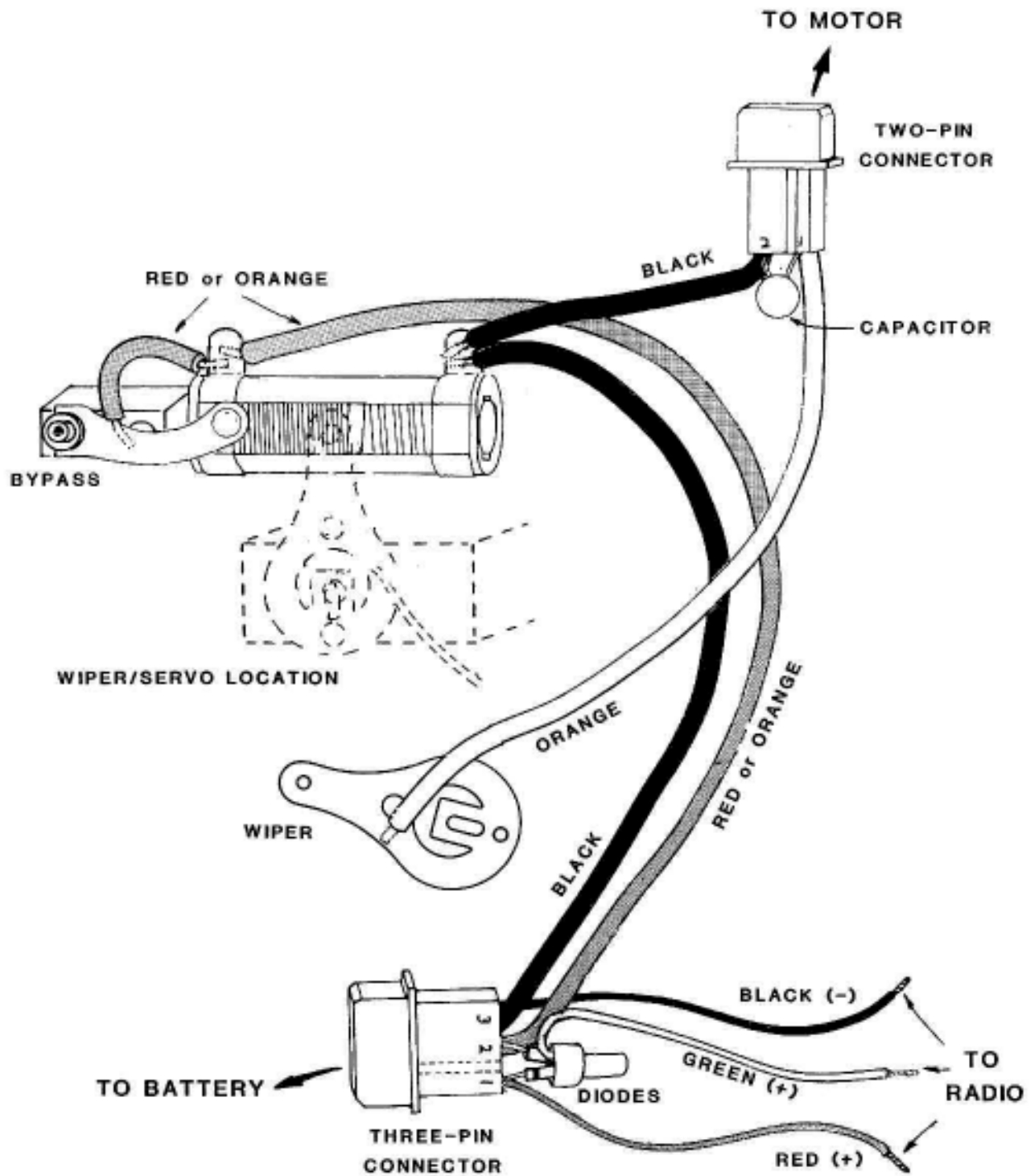

Fig. 214

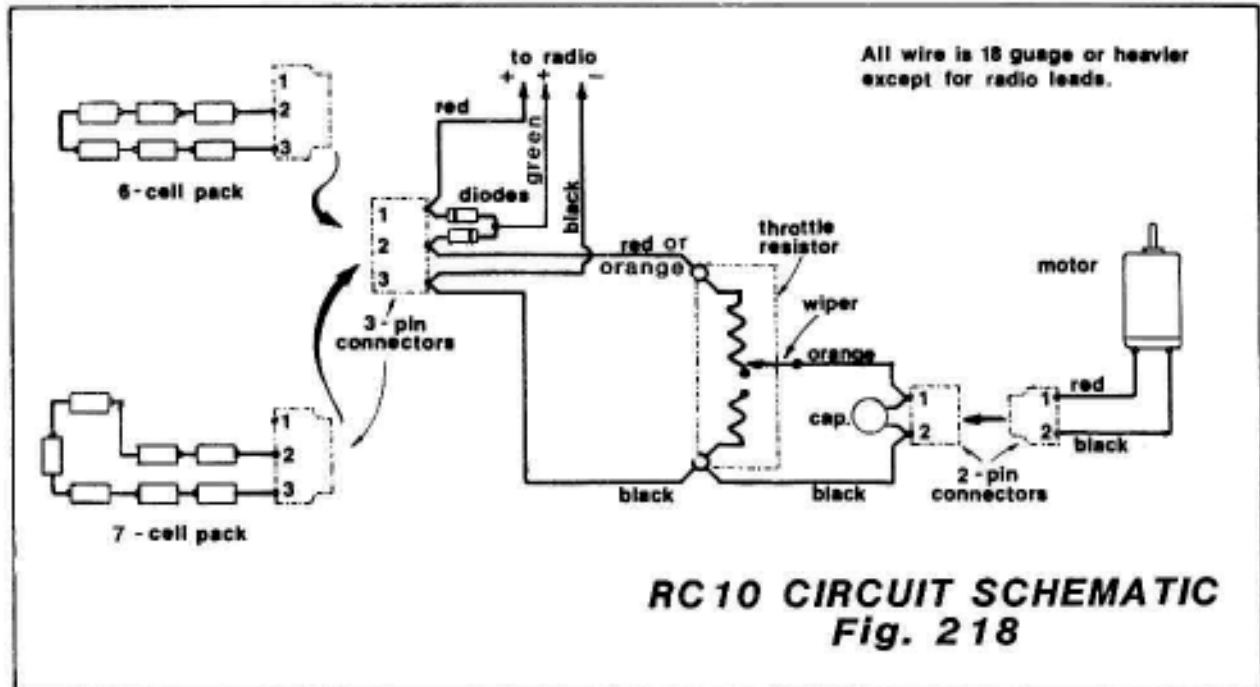
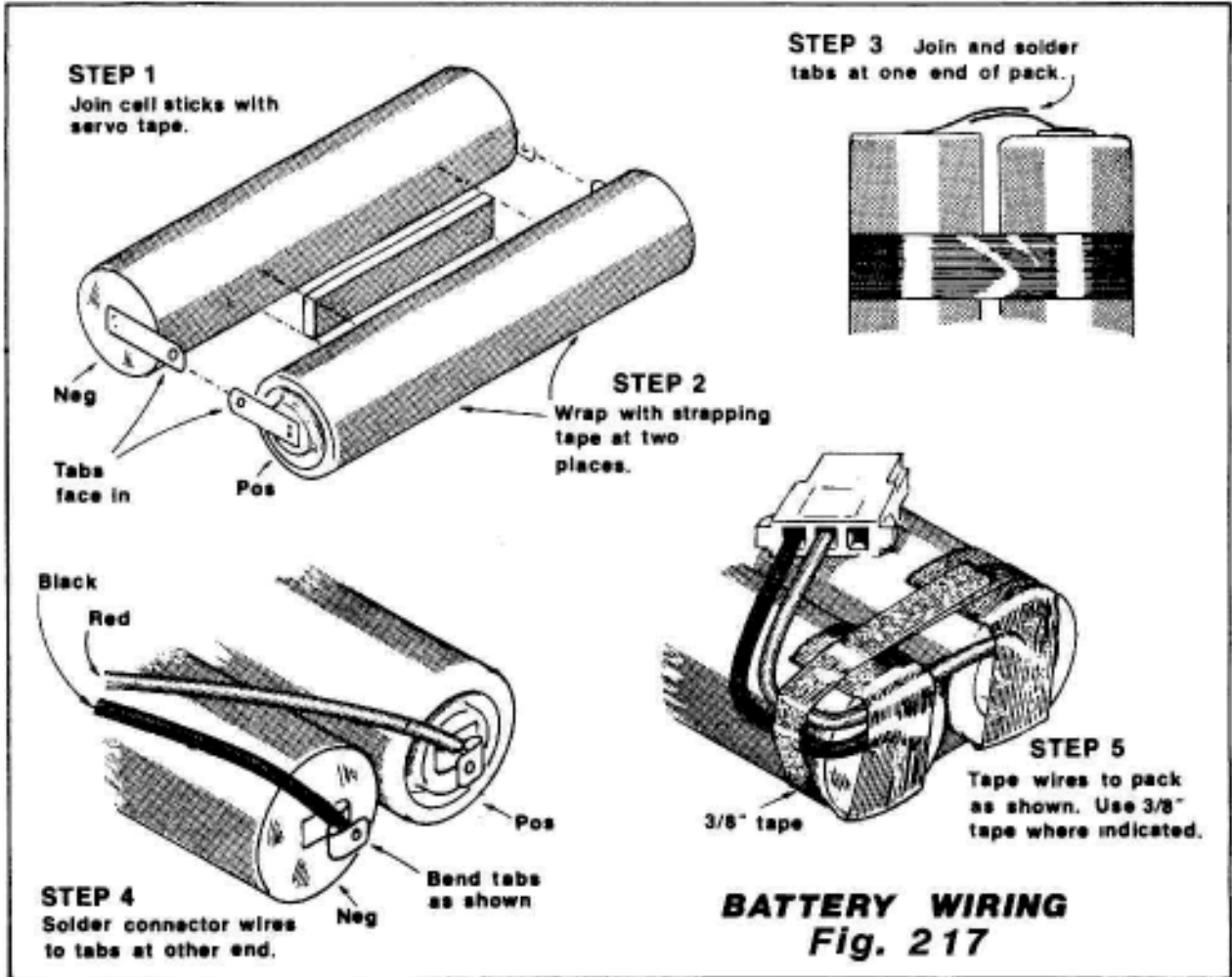

Fig. 215



NOTE: Use green and black radio leads with 6-cell pack. Use red and black radio leads with 7-cell pack.

**RC10 WIRING DIAGRAM**  
**Fig. 216**



## PARTS LIST

#6000 BASIC KIT contains the following:

- Chassis
- Rear wheels/tires
- Front wheels/tires
- Antenna kit
- Dif Lube
- Shock wrench / ball joint tool
- Headlamp set
- Knock-off set
- Bag #6-1 Front suspension
- Bag #6-2 Servo saver
- Bag #6-3 Front anti-roll bar
- Bag #6-4 Chassis parts
- Bag #6-5 Body mounts
- Bag #6-6 Servo mounts
- Bag #6-7 Battery mounts
- Bag #6-8 Rear suspension
- Bag #6-9 Rear shocks
- Bag #6-10 Front shocks
- Bag #6-11 Springs and oil
- Bag #6-12 Transmission
- Bag #6-14 Ball ends
- Bag #6-15 Gears

#6012 FULL KIT contains the following additional items:

- Motor
- Servo tape
- Wire ties
- Bag #6-13 Electrical items
- Bag #8-6 Charge cord

#6010 FULL KIT contains all of the above plus the following:

- Body
- Wing kit

#6016 FULL KIT is a #6010 kit with ball bearings

#6020 FULL KIT is a #6010 kit with a 6-cell ni-cad pack

## RACING YOUR RC10

**Tuning to win** - The RC10 has already won both classes of the ROAR Nationals and has also won the ORRCA Nationals, and the 2WD class of the World Championships against the toughest off road competition in the world. So your RC10 car is capable of the same performance. The first thing to do is to learn to drive the car, to the point that you're thoroughly familiar with how it handles. Only then can you start to make changes on the car, and be sharp enough to tell exactly how each change affects the car.

**Things to try** - You can change the dampening of the car by changing the oil in the shocks. 30W oil will make the shocks a little harder to actuate. 40W is getting near the maximum to try. Your kit contains 2 different sets of springs to try on your track. Each off road track is different. So the object is to find the ideal combination of springs, dampening, ride height, gearing, cambers, wing, etc. The racer that comes the closest to the ideal combination for his track, will have the easiest car to drive, which will give him the best chance to win.

**Oval racing** - Because the RC10 chassis is fully race tune-able, it can be adjusted to give ultimate oval track performance. Springs, dampening, ride height, wings and especially camber, can be adjusted to an ideal oval combination. Try giving the front and rear outside wheels up to 10 deg of increased camber.

**Differential adjustment** - The limited-slip (VariLok) ball differential on your RC10 works just like the dif on a full sized car - it allows the outside rear wheel to turn slightly faster than the inside when the car is cornering. The limited-slip feature prevents that wheel from turning too fast when cornering under power.

You can make sure the dif on your car is working properly by doing the following: Remove the gear dust cover. Lift the rear of the car off the ground with your left hand and press your thumb against the teeth of the large plastic gear to prevent it from turning. Now turn the right rear wheel with your other hand. The wheel should turn easily, and the OTHER wheel should turn in the opposite direction as you do it. A well set up dif will act the same way even if you don't hold the large gear from turning; just the drag of the motor should be enough to hold it.

Now place the car on the ground and push down on the rear end to compress the suspension. While holding the car in this position, try to turn the large gear with your thumb. It should be nearly impossible to turn the gear, and if it does turn the wheels should turn with it.

If your dif isn't working properly and adjustment of the dif nut doesn't fix it, then remove dif nut, spring, hub, drive rings, and large gear. Now you can make two checks: lift the car and make sure that both rear wheels will spin freely. Next, grab hold of the inner dif hub (the aluminum thing you just took the gear off of) and try to turn it while holding the RIGHT wheel. There should be no slippage. Now temporarily slide the outer dif hub back on the dif shaft and try to turn it while holding the LEFT rear wheel. Again there should be no slippage. If you can pass these tests then you can be pretty sure that the gears are not slipping or binding inside the transmission.

Next, clean, regrease, and reassemble the parts you removed. Make sure that the large gear turns freely on the inner dif hub as you put it together.

**Locking the dif** - In some situations you might want to lock the dif completely. To do this, simply remove the dif balls from the large gear, wipe off the grease from the gear and drive rings, and reassemble as usual, but without the balls. Tighten the nut all the way down to the point where the spring is almost fully compressed.

If the dif fails to lock up even when the spring is fully compressed then the inside of the outer hub (part #6624 in Fig. 78) may be bulged slightly, preventing complete lockup when assembled without the balls. This problem can be fixed by sanding off the bulge by rubbing it against a piece of emery paper laying on a flat surface. (The bulge is on the side OPPOSITE from the spring cup ... don't sand off the spring cup!)

NEVER attempt to lock the dif by assembling without the spring, and DO NOT overtighten the dif nut to the point where the spring is completely collapsed. A certain amount of slippage under impact is necessary to protect the gears from damage.

## MAINTENANCE

You'll find your RC10 car will give you many more hours of trouble free operation than any other car available now. The things to periodically check are all of the moving parts. Front and rear "A" arms, steering block, steering linkage, shocks etc. If any of these should get any dirt in them and start sticking, it will greatly affect how the car handles.



**Motor maintenance** - Because we're running out in the dirt, it is possible for dirt to make the brushes stick. So, if you're having motor problems, one of the first things to check is to make sure the brushes are still able to move freely in the brush holders. If you've run enough to wear them out, Associated has replacement brushes available. An item which will give you a little more power and make the brushes and commutator last much longer, is Associated's Reedy-in-a-Can Power Spray #6550. Simply spray a short burst of this on the brushes and commutator before you run and it will clean and lubricate the brushes and commutator. For those of you that want more power, there are Reedy Modified motors available. The #6510 is used for off road tracks and the #6511 is for oval track racing.

### RADIO PROBLEMS

A radio problem is not always caused by the radio. Often it is the result of a combination of factors that can include motor noise, poor electrical connections or layout, reversed or defective crystals, weak transmitter battery, etc., etc. If your radio problems persist one or all of the following may help:

- Make sure your motor noise capacitors are properly installed.
- Make sure the brushes are free in their brush holders, and are not arcing.
- Try a different frequency.
- Try a different motor.
- Lengthen your receiver antenna and/or raise the antenna mount up to the rear shock strut.
- Mount the receiver on the shock strut. Dress the radio wires well away from the power leads of the motor.
- Use a separate battery pack for the radio. (See section on separate packs).

Note also that 72 and 75 band radios, and Electronic Speed Controls are more susceptible to interference. Large metal objects such as chain-link fences, light poles, cars, vans, or trailers parked near the track can cause local interference particularly on 72 or 75 MHz.

**Resistor or Electronic Speed Control** Which is the best? Good question. We've found it's very hard to tell the difference in the performance of a properly working resistor with bypass, and an electronic speed control. However, for those of you who want to use a speed control, Associated has two good ones by Novak. They are a little complicated to install and adjust, but they require less maintenance than a resistor. Be sure you use the heat sinks.

**SEPARATE RADIO BATTERY PACK** - Cars with throttle control resistors can carry an additional battery pack to operate the radio. The advantage of a separate pack is that you don't lose radio control of the car when the main battery pack starts to die off. In a race it could mean an extra lap. If you're running in front of your house it could save the car from wandering into the street when the battery is nearly dead.

The disadvantage of a separate radio pack is that it is one more battery that you have to charge or change. A radio pack can run for an hour or more before it must be charged; but IF YOU FORGET you could lose control of the car while the main pack is fully charged, which means the car could get into trouble, FAST.

If you decide on a separate pack Associated offers a 5-cell 450 mah rechargeable Ni-Cd pack (#NR-5C). It will fit in the space between the main pack and the receiver if you stand the receiver on edge. Use servo tape to hold things in place. The pack is supplied with a Futaba connector. If you have a different radio you may have to change connectors. Charge with a transmitter and receiver pack charger, (Futaba FBL8B).

### CHARGING BATTERIES

It is important to understand the characteristics of the battery pack in your car because how you use it will greatly affect both its performance and life. With proper care your pack will perform well for many hundreds of cycles.

The R.O.A.R. legal battery supplied with your car is composed of six "sub-C" size cells with a maximum rated capacity of 1.2 amp-hr This means that the cells will supply 1.2 amperes for one hour, or 2.4 amperes for 1/2 hour, etc. This charge capacity is the same regardless of the number of cells in the pack because the cells are connected in series and the same current passes through each one.

**Chargers** - The RC10 kits that include the electrical components, include a charge cord. This will charge your batteries as well as anything else. However, Associated makes a #6772 Off Road Charger which will make your charging a whole lot easier. It includes an ammeter, to show the charge rate, and a 30 minute adjustable timer. Associated also has the Novak automatic charger which shuts off automatically when the batteries are fully charged.

**Overcharge.** There is no way to make a Ni-Cd cell accept more charge than it is designed to hold. This means that as the cell approaches a fully charged condition the portion of charging current not being stored becomes heat and pressure. If charging continues after the cell is

fully charged, all of the current is converted to heat and pressure - about 40 watts worth - or the equivalent of the heat produced by an average soldering iron. High temperature and pressure is harmful to the cells, so overcharging should be avoided.

Ni-Cd cells have a built-in process for recombining the accumulated gas (actually oxygen) produced by overcharge, but the process produces heat and takes a lot of time. If you overcharge your battery and it seems to take a long time to cool down, it's because this pressure reducing reaction is taking place. Once the gas is recombined the temperature drops.

**HOW TO TELL WHEN YOU'RE CHARGED** - One of the problems with Ni-Cds is their inherent voltage stability; the voltage of a fully charged cell is not much different from one that's about dead. For that reason several indicators, along with some common sense, are needed in order to get the most out of your battery. The following is a list of indications you can use to detect full charge.

**Temperature Method** - This works well if you start with a cool battery pack. As the pack charges, frequently check its temperature by feeling the cells directly. As soon as you notice an increase in temperature stop charging. If the cells become too hot to hold on to, you are overcharged. Let them cool.

**Timed Charge Method** - This only works if you have confidence in the timing accuracy of your charger. Many chargers on the market only approximate a constant charging current; they may vary from six amps when you first start charging all the way down to two amps if the Ni-Cd pack is nearly charged and the voltage of the charging source (automobile battery) is low. If the charging current varies, it becomes difficult to estimate the average current. However, if your charger is reasonably dependable you can use the following method.

Charge your pack using the temperature method and keep track of the time required to reach full charge. Once you have established the time you can use it as a setting for the timer on your charger. To be safe use a setting about a minute less than what you established. This method allows you to charge without constantly monitoring the battery temperature.

**Voltage Method** - Voltage is a poor indication of a cell's state of charge. Things like temperature, current drain, and "cell memory" have as much an effect on voltage as the state of charge does. However, it is possible to see the cell voltage gradually climb during the charging process. The absolute value of this voltage isn't much use, but how the voltage

changes is an excellent indication. To use this method you will need a digital voltmeter.

Connect the voltmeter across the Ni-Cd pack, preferably right at the cell terminals, or if that's not possible, across the terminals of the throttle control resistor. Don't try to read the voltage at the output of the charger because you'll end up reading the voltage drop through all the connectors and cables between the charger and the Ni-Cd pack; and that can sometimes mask the effect you're looking for. You should start with a Ni-Cd pack that is less than 1/2 charged. Connect your charger and begin charging at four amps. If your charger is adjustable set the current now, but don't try to change it later. A constant current charger is preferable here, but if yours gradually drops off during charge, that's okay; as long as it doesn't drop below three amps.

Watch the voltage as the pack charges. Notice that the voltage climbs rapidly at first, and then very slowly in the middle of the charging cycle. This voltage will most likely be in the range of 8 1/2 to 9 volts for a six cell pack. As the pack approaches full charge, the voltage will begin to climb more rapidly; and as it goes into overcharge the climb will slow down and stop. This is where you stop charging: at the point where the voltage stops climbing. If you left the charger on, the voltage would begin to fall as the pack went deeply into overcharge and started to heat up. The maximum voltage reached will probably be in the nine to ten volt region; the actual value is unimportant.

**Trickle Charge Method** - Slow or "over-night" charging is a method you are not likely to use often. It is a good way to bring the pack to absolutely full charge. However, the output voltage of a trickle charged pack is slightly lower.

**GETTING MAXIMUM PERFORMANCE** - The paragraphs that follow are really for the benefit of serious racers. If you're just out having fun, don't worry about it.

**Full Discharge** - Ni-Cd packs perform best if they are **completely** discharged before they are charged. If you are involved in racing you will have to do this if you expect to win any races! Associated Chargers have a discharge function and various clip-on discharge resistors (about 30 ohms, 10 watts) are available at hobby stores. Discharge for at least an hour (preferably overnight with a clip-on resistor) before charging.

**Topping-up** - can give you a little extra voltage at the beginning of a race, as long as you don't overdo it. Put the last minute or two of charge into your pack just before the race starts.

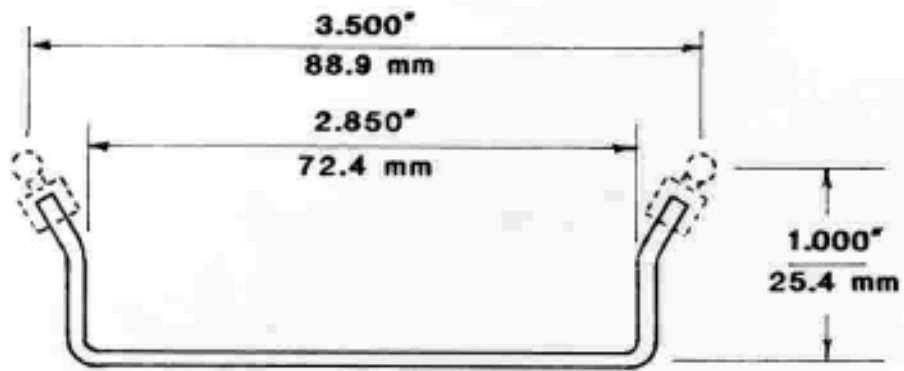

**FRONT ANTI-ROLL BAR TEMPLATE**

**Fig. 219**

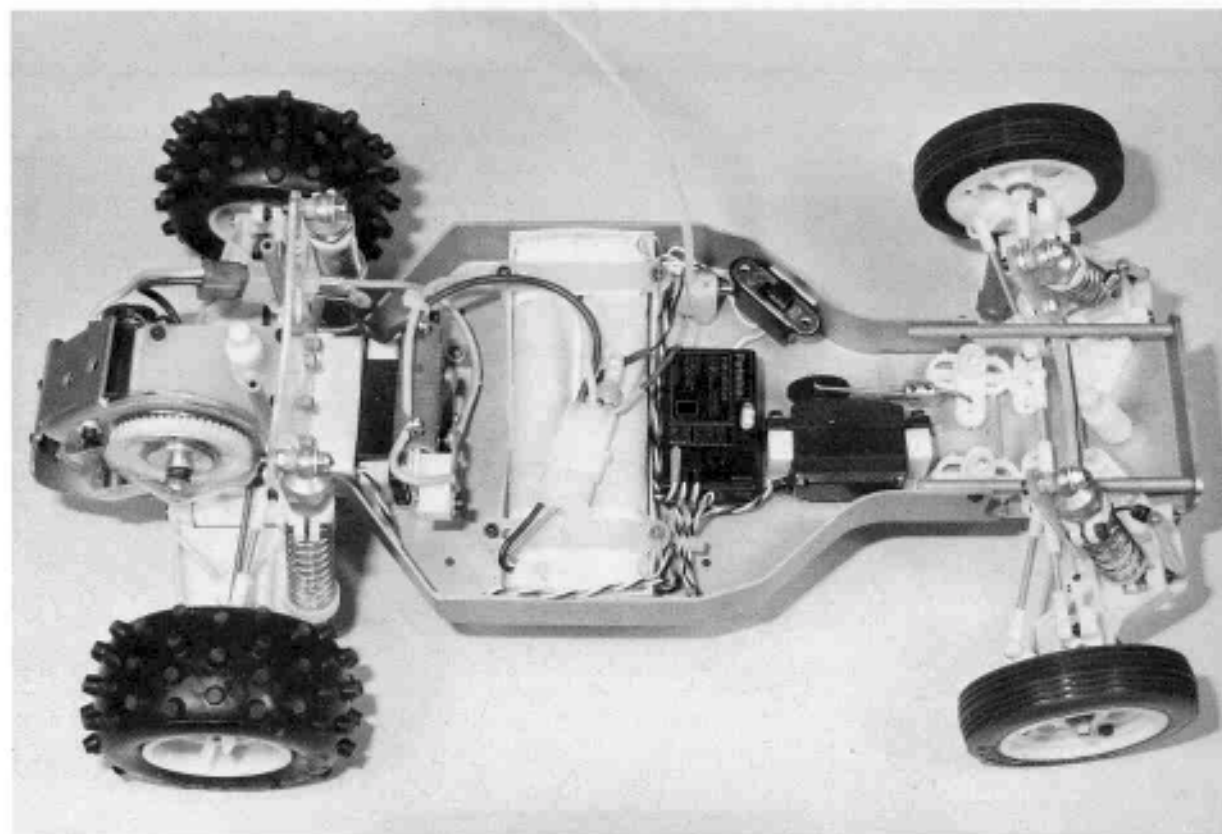

**TEAM ASSOCIATED**

3585 Cadillac Ave., Costa Mesa, CA 92626 • USA  
Phone (714) 850-9342 Telex 756887