

Rear	Alignment	Front
5.0mm	Ride Height	5.0mm
-1.5°	Camber	-1.5°
N/A	Caster	4°
0°	Rear Hub Toe	N/A
-2.5°	Toe	0°
0.5mm	Hex Spacing	0
2mm	Wheelbase	2mm
N/A	Steering Link	1A
N/A	Bumpsteer	2mm-Silver

Notes:

Diff	Type	Spool
1/8 turn open	Setting	---
8A	Belt Tension Number	1A
A	Cam Holder	A

Notes:

RP-30	Tires	RP-30
	Tire	
	Tire Diameter	
	Insert & Wheel Additive & Amount	

Notes:

35wt	Shocks	35wt
#3	Oil	#3
50%	Piston	50%
Silver	Rebound	50%
	Spring	Gold

Notes:

Chassis:	ITF
Top Plate:	ITF

	Suspension Geometry	
3B	Shock Position	2B
5A	Camber Link Position	3
Black-2mm	Outer Ball & Shims	Black-0
3A	FWD Arm Mount	2A
0	FWD Mount Shims	0
3A	RWD Arm Mount	2A
2.5°	RWD Mount Shims	0
5	Drop	6
---	Anti-Roll Bar	---

Notes:

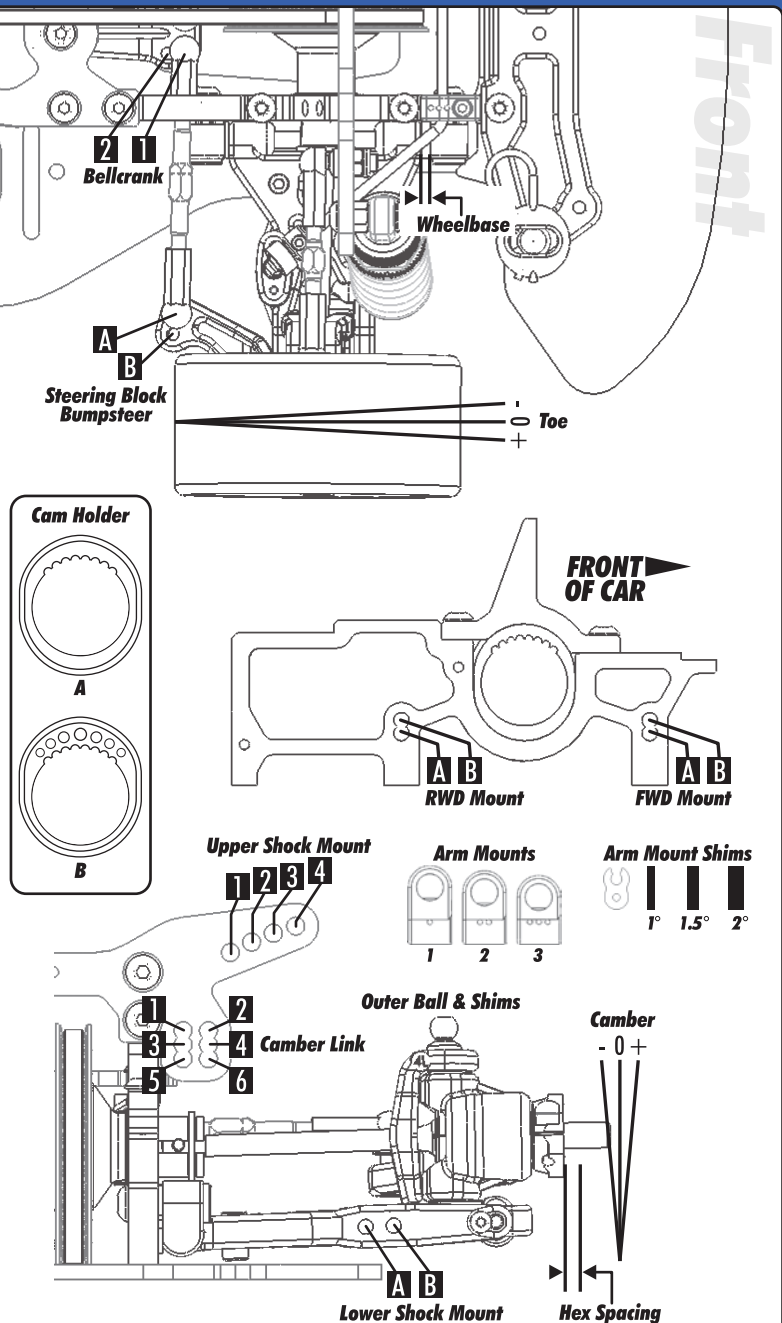

Body & Wing
MAZDA 6 L.W.

Battery
5-CELL FWD

Motor	Gear	Brush	Spring	Timing
LRP X11 3.5T	21/89			