



Date: \_\_\_\_\_

Driver: \_\_\_\_\_

Track: \_\_\_\_\_

Tight /  Open

Loose Dirt /  Hard-Packed

### FRONT SUSPENSION

(CIRCLE OR CHECK CORRECT SETTINGS)

TOE-IN /  TOE-OUT: \_\_\_\_\_ °

FRONT RIDE HEIGHT: \_\_\_\_\_

FRONT CAMBER: + \_\_\_\_\_ °

NOTES: \_\_\_\_\_

#### FRONT SHOCKS

OIL: \_\_\_\_\_

PISTON: \_\_\_\_\_  DRILLED /  STANDARD

SPRING: \_\_\_\_\_

LIMITERS: INSIDE- \_\_\_\_\_ , OUTSIDE- \_\_\_\_\_

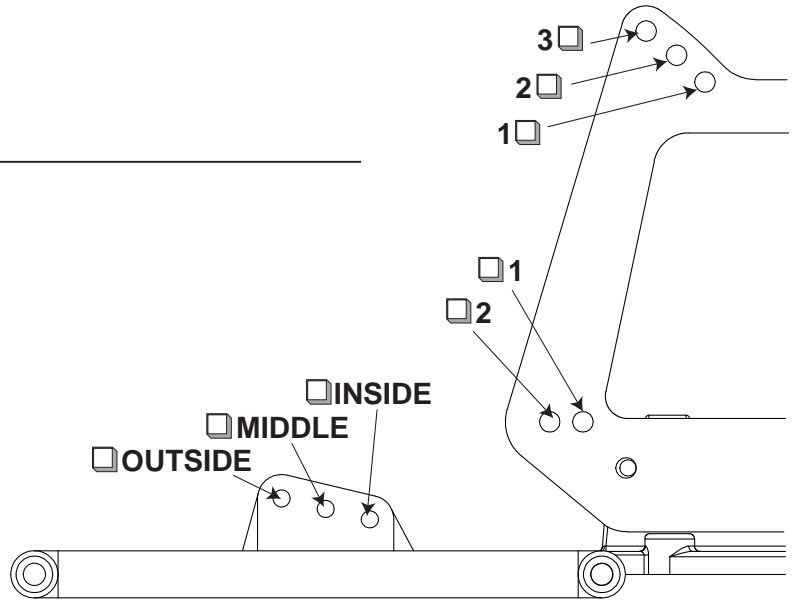

### REAR SUSPENSION

PIVOT SUPPORT:  #2,  #4

REAR PIVOT:  NARROW,  WIDE

REAR RIDE HEIGHT: \_\_\_\_\_

REAR CAMBER: + \_\_\_\_\_ °

NOTES: \_\_\_\_\_

#### REAR SHOCKS

OIL: \_\_\_\_\_

PISTON: \_\_\_\_\_  DRILLED /  STANDARD

SPRING: \_\_\_\_\_

LIMITERS: INSIDE- \_\_\_\_\_ , OUTSIDE- \_\_\_\_\_

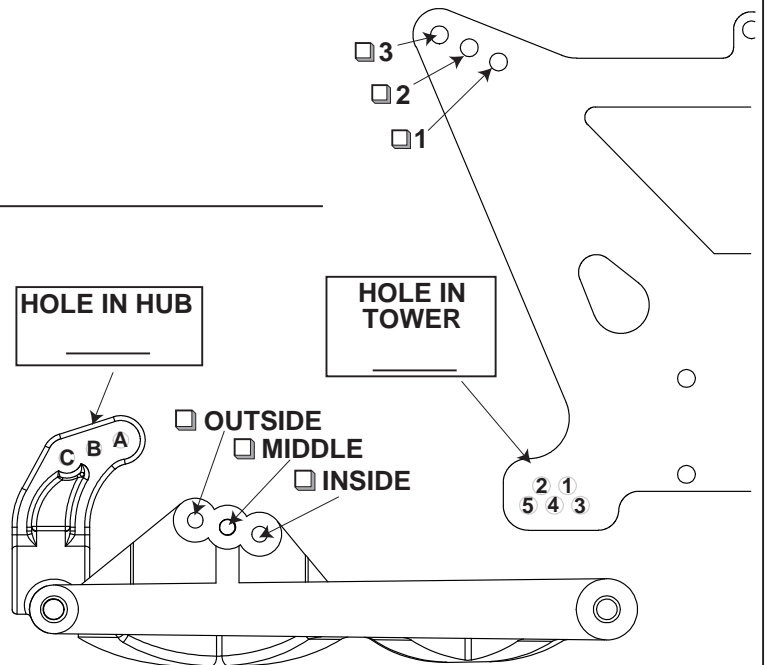

### TRANSMISSION & CHASSIS

FRONT TIRE: \_\_\_\_\_ COMPOUND: \_\_\_\_\_ ENGINE: \_\_\_\_\_

REAR TIRE: \_\_\_\_\_ COMPOUND: \_\_\_\_\_ CLUTCH BELL: \_\_\_\_\_

CLUTCH NOTES: \_\_\_\_\_ SPUR GEAR: \_\_\_\_\_

FUEL: \_\_\_\_\_