



OWNER'S MANUAL



- ① Carefully read through all instructions to familiarize yourself with the parts, construction techniques, and tuning tips outlined in this manual. Being able to grasp the overall design of your new XXX-4 Buggy before beginning the construction process will ensure a smooth assembly.
- ② Take your time and pay close attention to detail. Keep this manual for future reference.



Always Racing Towards The Future.

Team losi, Division of Horizon Hobby inc.,
4710 Gausti Rd., Ontario CA 91761
phone: (909) 465-9728 / Fax: (909) 590-1496
www.TeamLosi.com / feedback@TeamLosi.com

MADE IN THE UNITED STATES OF AMERICA

P/N 800-0186
8/29/2002
RWW

Welcome Team Losi XXX-4 Owner!

Thank you for selecting Team Losi and the XXX-4 as your new racing Buggy. As you will see, we have made every effort to design and produce a kit that is not only the most competitive, but easy to build and maintain. The simple bag-by-bag assembly sequence and unmatched easily followed instructions, combined with Team Losi's world famous quality-fitting parts, should make building your new XXX-4 a most enjoyable project.

Before you open the first bag or start any assembly, please take a few moments to read completely through the following instructions. This will familiarize you with the various parts as well as the tools you will need. Taking an extra moment before starting can save you a good deal of time and assure proper assembly.

Once again, thank you for choosing Team Losi.

Good luck and good racing!

1. INTRODUCTION

XXX-4 COMPLETED KIT DIMENSIONS

Overall Length: 15-3/8"
Wheelbase: 10-3/4"

Front Width: 9-3/4"
All dimensions at ride height.

Rear Width: 9-5/8"

Height: 5-3/8"
Weight will vary depending on accessories.

NOTES & SYMBOLS USED

Step A-1

This is a common Step sequence found at the beginning of each new illustration throughout the manual.

1. Each step throughout the entire manual has a check box to the left of it. As you complete each step, mark the box with a check. If you need to take a break and return to building at a later time you will be able to locate the exact step where you left off.

 This is a common note. It is used to call attention to specific details of a certain step in the assembly.

 **IMPORTANT NOTE:** Even if you are familiar with Team Losi kits, be sure and pay attention to these notes. They point out very important details during the assembly process. Do not ignore these notes!

 In illustrations where it is important to note which direction parts are facing, a helmet like this one will be included in the illustration. The helmet will always face the front of the car. Any reference to the right of left side will relate to the direction of the helmet.

KIT/MANUAL ORGANIZATION

The kit is composed of different bags marked A through H. Each bag contains all of the parts necessary to complete a particular section of the XXX-4. Some of these bags have subassembly bags within them. **It is essential that you open only one bag at a time and follow the correct assembly sequence, otherwise you may face difficulties in finding the correct part.** It is helpful to read through the instruc-

tions for an entire bag prior to beginning assembly. Key numbers (in parenthesis) have been assigned to each part and remain the same throughout the manual. In some illustrations, parts which have already been installed are not shown so that the current steps can be illustrated more clearly.

For your convenience, an actual-size hardware identification guide is included with each step. To check a part, hold it against the silhouette until the correct part is identified. In some cases extra hardware has been supplied for parts that may be easy to lose.

The molded parts in the XXX-4 are manufactured so that they interlock. **When screws are tightened to the point of being snug, the parts are held firmly in place.** For this reason it is very important that screws not be overtightened in any of the plastic parts.

To ensure that parts are not lost during construction, it is recommended that you work over a towel or mat to prevent parts from rolling away.

IMPORTANT SAFETY NOTES

1. Select an area for assembly that is away from the reach of small children. **Some parts in this kit are small and can be swallowed by children, causing choking and possible internal injury.**

2. The shock fluid and greases supplied should be kept out of childrens' reach. **They are not intended for human consumption!**

3. **Exercise care** when using *any* hand tools, sharp instruments, or power tools during construction.

4. **Carefully read all manufacturers' warnings and cautions** for any glues, chemicals, or paints that may be used for assembly and operating purposes. **When you are using glues, chemicals, and paints you should always wear eye protection and a mask.**

TOOLS REQUIRED

Team Losi has supplied all necessary allen wrenches and two special assembly wrenches that are needed for slipper adjustment, assembly and turnbuckle adjustments. The following common tools will also be required: Needle-nose pliers, regular pliers, medium grit sandpaper, hobby knife, scissors, and body cutting/trimming tools. A soldering iron may be necessary for electrical installation. 3/16", 1/4", and 11/32" nut drivers are optional.

RADIO/ELECTRICAL

A suggested radio layout is provided in this manual. Your high-performance R/C center should be consulted regarding specific questions pertaining to radio/electrical equipment.

HARDWARE IDENTIFICATION

When in question, use the hardware identification guide in each step. For screws, the prefix number designates the screw size and number of threads per inch (i.e. 4-40 is #4 screw with 40 threads per inch). The second number or fraction designates the length of the screw. For cap head and button head screws, this number refers to the length of the threaded portion of the screw. For flat head screws, this number refers to the overall length of the screw. Bearings and bushings are referenced by the inside diameter x outside diameter. Shafts and pins are referred to by diameter x length. Washers are described by inside diameter or the screw size that will pass through the inside diameter. E-clips are sized by the shaft diameter that they attach to.

MOTORS AND GEARING

The XXX-4 includes an 92-tooth, 48-pitch spur gear. The internal drive ratio of the XXX-4 is 2.10. The pinion gear that is used will determine the final drive ratio. To calculate the final drive ratio, first divide the spur gear size by the pinion gear size. For example, if you are using a 20-tooth pinion gear, you would divide 92 (spur gear size) by 20 (pinion gear size). $92/20 = 4.60$. This tells you that 4.60 is the external drive ratio. Next, multiply the internal drive ratio (2.10) by the external drive ratio (in this case 4.60). $2.10 \times 4.60 = 9.66:1$. This means that by using a 20-tooth pinion gear with the standard 92-tooth spur gear, the final drive ratio is 9.66:1.

Consult your high-performance shop for recommendations to suit your racing style and class. The chart below lists some of the more common motor types and recommended initial gearing for that motor. Ratios can be adjusted depending on the various track layouts, tire sizes, and battery types.

RECOMMENDED INITIAL GEARING FOR COMMON MOTORS

TYPE OF MOTOR	PINION	SPUR
24° Stock	25	92
8-Turn Modified	16	92
9-Turn Modified	17	92
10-Turn Modified	18	92
11-Turn Modified	19	92
12-Turn Modified	20	92
13-Turn Modified	21	92
14-Turn Modified	22	92
15-Turn Modified	23	92

TABLE OF CONTENTS

1. INTRODUCTION	i	4. BAG C	12-15
Completed Kit Dimensions	i	5. BAG D	16-20
Notes & Symbols	i	6. BAG E	21-25
Kit Manual Organization	i	7. BAG F	26-28
Important Safety Notes	i	8. BAG G	29
Tools Required	ii	9. BAG H	30-34
Radio/Electrical	ii	10. Checklist Before Your First Run	35
Hardware Identification	ii	11. Tips From the Team	35-37
Recommended Gearing	ii	12. Spare Parts List	38-41
2. BAG A	1-7		
3. BAG B	8-11		

Team Losi is continually changing and improving designs; therefore, the actual part may appear slightly different than the illustrated part. Illustrations of parts and assemblies may be slightly distorted to enhance pertinent details.

BAG A

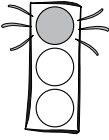

STOP! There are two, complete differential assemblies in the XXX-4 kit. The Front - plastic differential, shown in steps A-1 thru A-9 and The Rear - steel differential, shown in steps A-10 thru A-19. The XXX-4 kit was designed using the stock 42T drive pulleys in the front and rear of the car. There is an optional 41T pulley included in Bag H of this kit, This feature can be used to apply under-drive or over-drive in the vehicle. See set-up tips at the end of this manual.

Step A-1 Diff Nut Carrier:



- 1. Insert a 4-40 mini lock nut (183) into the hex area of the diff nut carrier (27). The thread-locking portion (plastic) of the nut should face the outside.

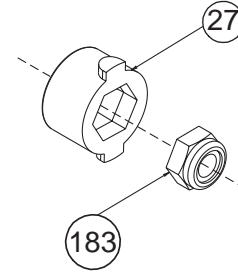

Figure 1

Step A-2 Diff Nut w/Belleville washers:



- 1. Locate the 1/16" Allen wrench (125) supplied with the kit. Place the diff nut carrier (27), nut side first, over the Allen wrench towards the "L-end."

- 2. Stack the six 1/8" Belleville washers (154) over the wrench and up against the diff nut carrier. The washers should all point the same direction and open away from the diff nut carrier as shown in Figure 2A.

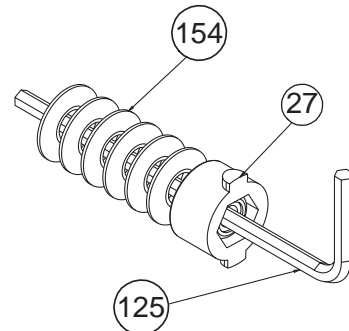

Figure 2A



Figure 2B

Step A-3 Diff Nut to Male Outdrive:

- 1. Insert all of the parts that are stacked on the wrench (125) into the plastic male outdrive/ diff half (19) (the one with the post). Line up the tabs on the diff nut carrier (27) with the slots in the male outdrive. Press the parts all the way into the male outdrive.

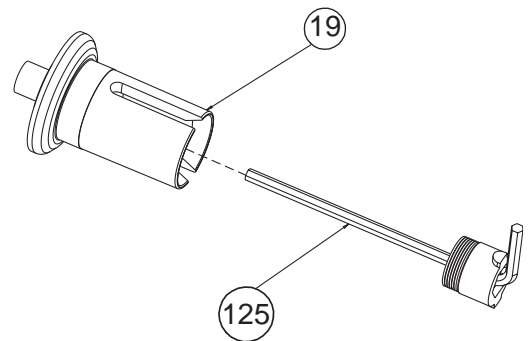

Figure 3

Step A-4 Diff Drive Ring to Male Outdrive

- 1. Apply a small amount of clear diff grease (172) to the outside ring of the plastic male outdrive (19). Attach a diff drive ring (108) to the male outdrive by lining up the flat section of the ring with the flat section on the outdrive.

**NOTE: Only a small amount of grease is needed. It is only used to hold the drive ring in place.*

! IMPORTANT NOTE: Do not glue the drive rings to the outdrive/ diff halves. Doing so may not allow the washers to mount flat.

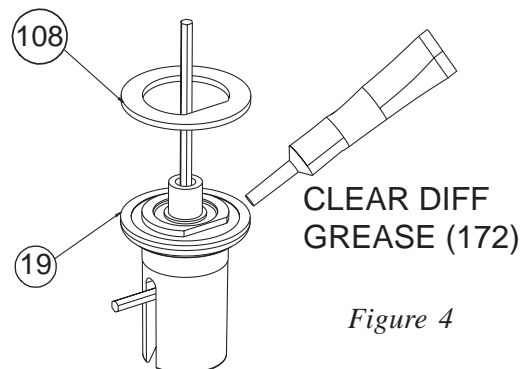
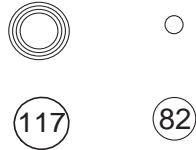

Figure 4

BAG A (Continued)

Step A-5 Diff Pulley



1. Insert a 5mm x 8mm Bearing (117) into the center of the 42T diff pulley (42).

2. Press a 3/32" diff ball (82) into each of the twelve small holes in the diff pulley as indicated in Figure 5.

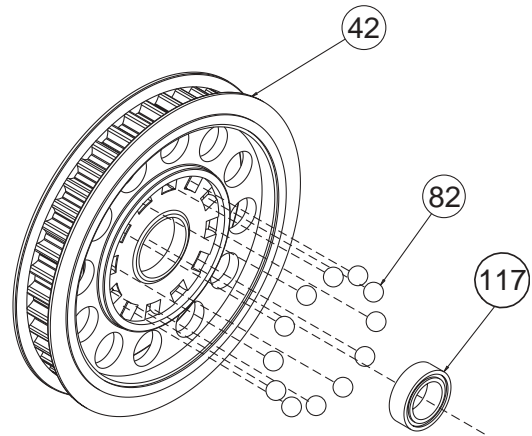
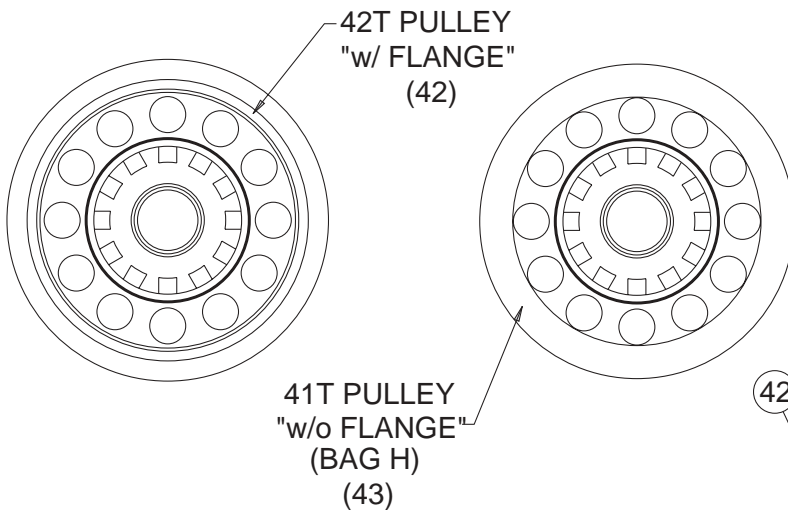

Figure 5

Step A-6 Diff Pulley to Male Outdrive



1. Apply a heavy coat of clear diff grease (172) to the exposed side of the diff ring (108) that is already attached to the outdrive (19).

2. Carefully place the diff pulley (42) over the post on the outdrive so that the diff balls (82) and diff pulley rest against the greased drive ring. Leave the assembly with the 1/16" Allen wrench (125) standing as shown in Figure 6.

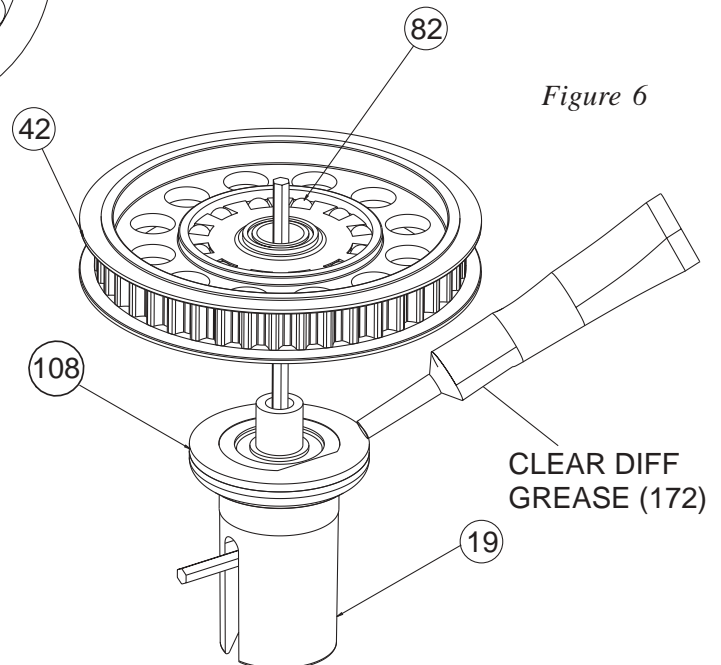

Figure 6

BAG A (Continued)

Step A-7 Bearing to Female Outdrive

- ❑ 1. Press a 5mm x 8mm bearing (117) into the center area of the female plastic outdrive/ diff half (20) as indicated. The edge of the bearing should be flush with the front of the outdrive.
- ❑ 2. Apply a small amount of clear diff grease (172) to the outer ring of the outdrive. Install the second drive ring (108), again aligning the flat sections of the outdrive and the drive ring.

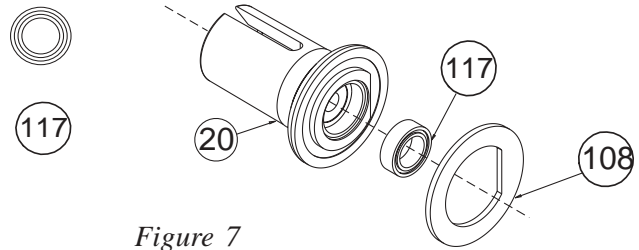
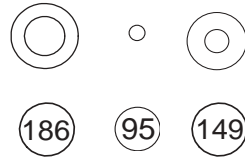

Figure 7

Step A-8 Female Outdrive Assembly



- ❑ 1. Place the foam thrust bearing seal (186) over the shoulder of the diff adjusting screw (91).
- ❑ 2. Place one of the 1/8" x 5/16" thrust bearing washers (149) over the diff screw.
- ❑ 3. Using the MIP RED grease (157), apply a fairly heavy coat of grease to the thrust washer and position the eight 5/64" thrust balls (95) in a circular pattern around the diff screw. Apply another coat of RED MIP grease over the thrust balls and place the second thrust bearing washer over the diff screw and up against the thrust balls.

**NOTE: The thrust bearing washers are packaged in a small bag along with the eight 5/64" thrust bearing balls.*

- ❑ 4. Insert the diff screw into the female outdrive (20). Pull the threaded end of the diff screw until the thrust assembly rests against the inside of the outdrive.

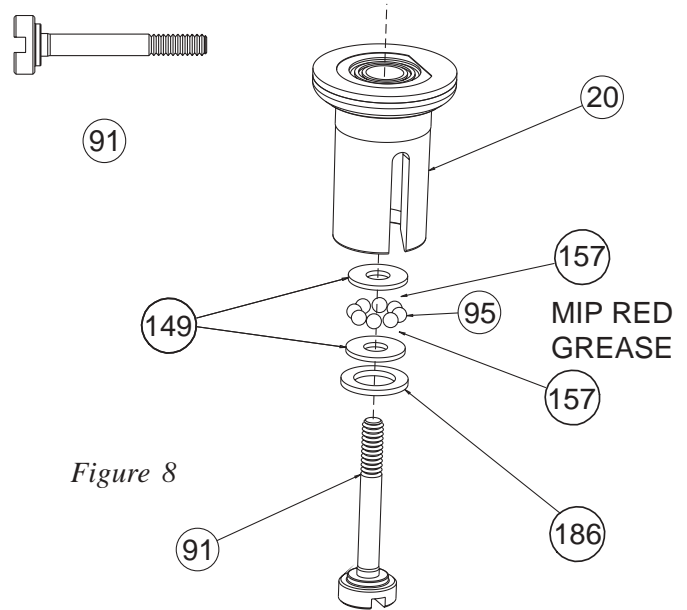



Figure 8

Step A-9 Male to Female Outdrive Assembly

- ❑ 1. Carefully replace the Allen wrench (125) with a pen or pencil from the male outdrive (19) and place it in the slot of the female outdrive (20) containing the diff screw (91). The pen will be used to hold the diff nut carrier (27) assembly in the bottom side.
- ❑ 2. Apply a good amount of clear grease (enough to cover the balls completely) (172) to the exposed side of the balls in the diff pulley (42) on the male outdrive.
- ❑ 3. While holding the female outdrive with Allen wrench inserted, carefully assemble it to the male outdrive.
- ❑ 4. Make sure that the slot in the diff screw is lined up with the slot in the female half and then while holding the male half slowly turn the female outdrive until the threads of the diff screw engage on the threads of the 4-40 mini nut (183). Remove the pencil from the male half and thread the two outdrives together until the screw just starts to snug up.
- ❑ 5. Tighten the diff until the pulley (42) cannot be turned while both of the outdrives are being held firmly. Final diff adjustment should be made after completion of the XXX-4.

 *When tightening the diff, tighten the screw a little and then "work" the diff a little. Then tighten the screw a little more and "work" the diff again. Continue this until the diff doesn't slip. This ensures that the parts in the diff are properly seated. Refer to tech tips for final adjustment. "Working" the diff is done by rotating the outdrives in opposite directions.*

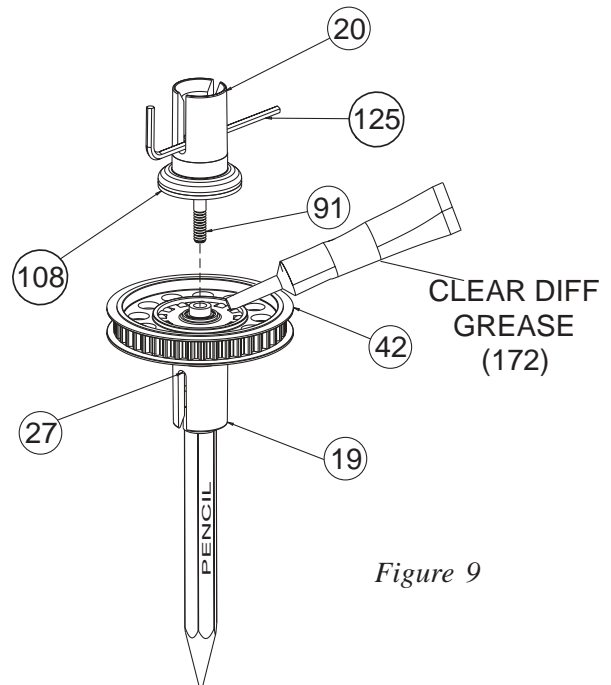

Figure 9

BAG A (Continued)

Step A-10 Diff Nut Carrier:



- 1. Insert a 4-40 mini lock nut (183) into the hex area of the diff nut carrier (27). The thread-locking portion (plastic) of the nut should face the outside.

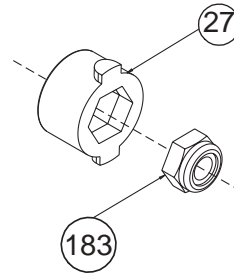

Figure 10

Step A-11 Diff Tube Assembly:



- 1. Locate the 1/16" Allen wrench (125) supplied with the kit. Place the diff nut carrier (27), nut side first, over the Allen wrench towards the "L-end."

- 2. Stack the six 1/8" Belleville washers (154) over the wrench and up against the diff nut carrier. The washers should all point the same direction and open away from the diff nut carrier as shown in Figure 2A.

- 3. Place the diff tube (86) over the wrench, large side first, so that it rests against the beveled washers.

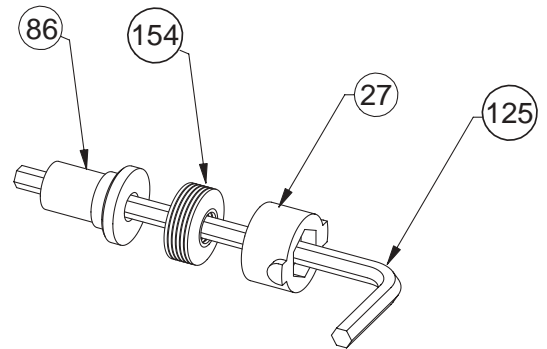

Figure 11A

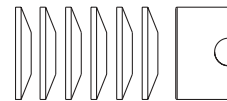

Figure 11B

Step A-12 Diff Tube Assembly to Outdrive:

⚠ IMPORTANT NOTE: Male outdrive defined as: Outdrive containing diff tube assembly (fig 11). Female outdrive defined as: Outdrive containing thrust assembly (fig 17).

- 1. Insert all of the parts that are stacked on the wrench (125) into the outdrive/ diff half (87). Line up the tabs on the diff nut carrier (27) with the slots in the outdrive. Press the parts all the way into the outdrive, so that the diff tube (86) is seated inside the outdrive.

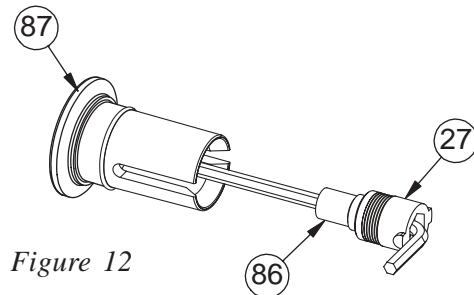
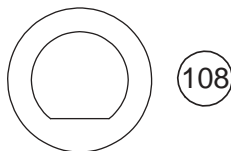

Figure 12

Step A-13 Diff Drive Ring to Male Outdrive



- 1. Apply a small amount of clear diff grease (172) to the outside ridge of the outdrive/diff half (87). Attach a diff washer (108) to the outdrive by lining up the flat section of the diff washer with the flat section of the outdrive.

**NOTE: Only a small amount of grease is needed. It is only there to hold the diff washer in place.*

⚠ IMPORTANT NOTE: Do not glue the diff washers to the outdrive/diff halves. Doing so may not allow the washers to mount flat.

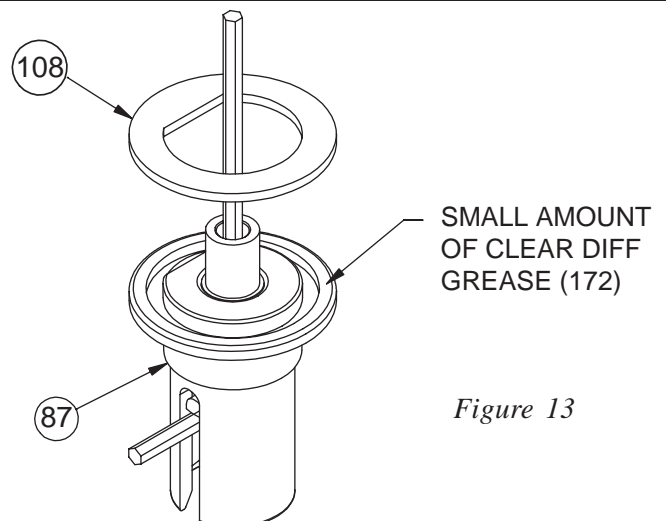

SMALL AMOUNT OF CLEAR DIFF GREASE (172)

Figure 13

BAG A (Continued)

Step A-14 Diff Pulley

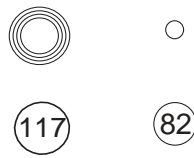

- 1. Insert a 5mm x 8mm Bearing (117) into the center of the 42T diff pulley (42).
- 2. Press a 3/32" diff ball (82) into each of the small holes in the diff pulley as indicated in Figure 14.

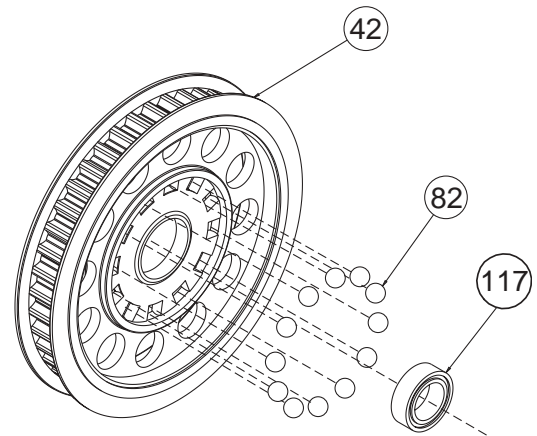
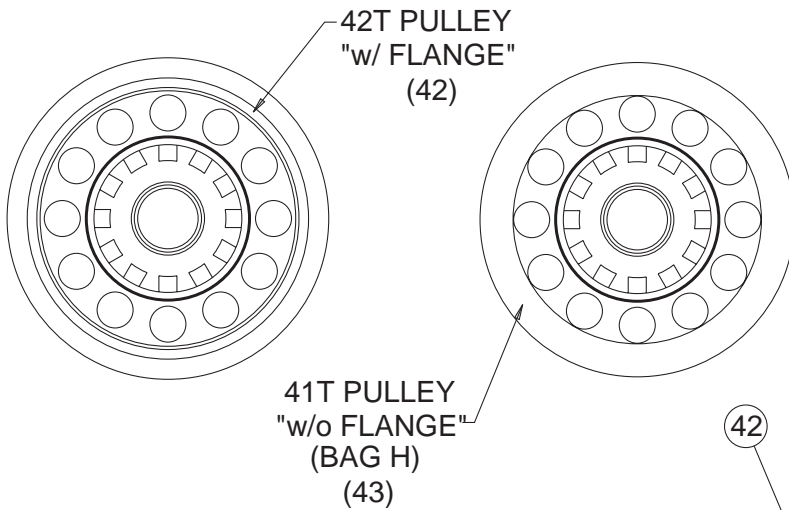

Figure 14

Step A-15 Diff Pulley to Diff Tube



- 1. Apply a heavy coat (same as step A-9) of clear diff grease (172) to the exposed side of the diff ring (108) that is already attached to the outdrive (87).
- 2. Carefully place the diff pulley (42) over the post on the outdrive so that the diff balls (82) and diff pulley rest against the greased diff ring. Leave the assembly with the 1/16" Allen wrench (125) standing as shown in Figure 15.

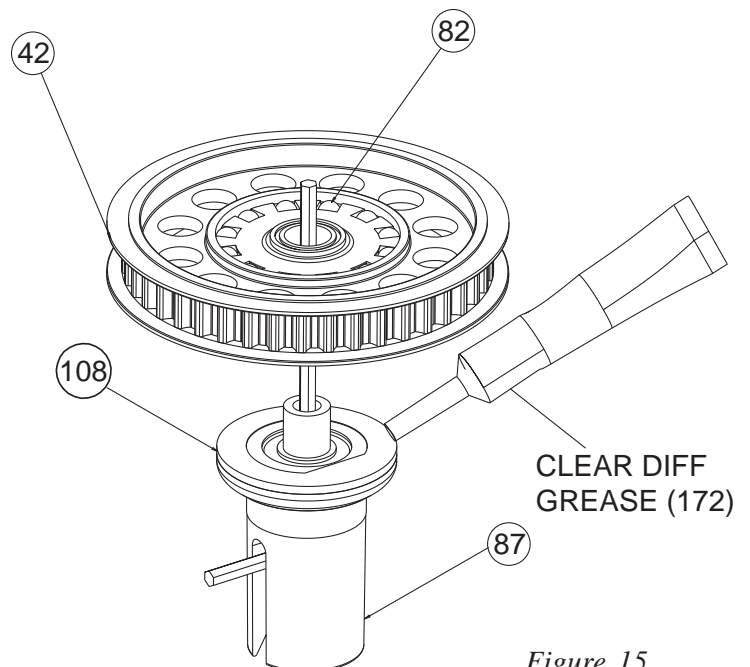
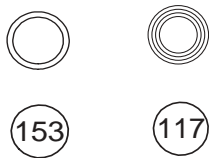

Figure 15

BAG A (Continued)

Step A-16 Bearing Insert



1. Insert a 5mm x 8mm bearing (117) into the second outdrive/diff half (87). Make sure that the bearing is pushed all the way into the outdrive. A pencil or the handle of a hobby knife can be used to push the bearing into place.

2. Apply a slight amount of clear diff grease (172) to the 1/4" x 5/16" shim (153). Insert the shim into the outdrive/diff half next to the 5mm x 8mm bearing. Make sure that the shim is flat against the bearing. *Be extra careful not to bend this shim!*

**NOTE: Only a small amount of grease is needed. It is only needed to hold the shim in place next to the bearing.*

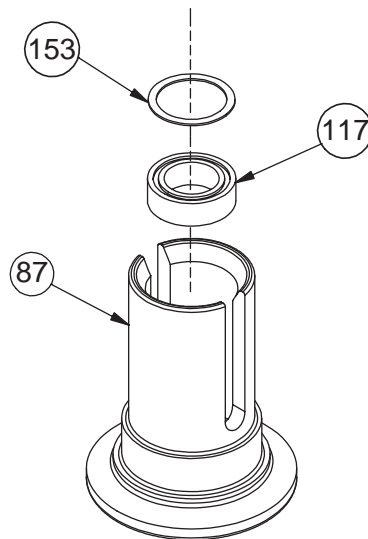
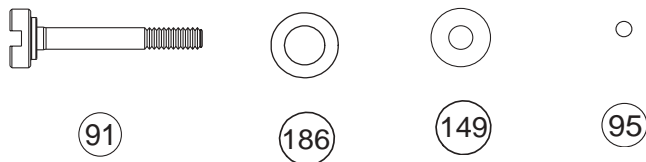

Figure 16

Step A-17 Diff Adjusting Screw Assembly



1. Locate the diff adjusting screw (91) and place the foam thrust bearing seal (186) over the shoulder of the screw.

2. Place one of the 3mm x 8mm thrust bearing washers (149) over the diff screw.

**NOTE: The thrust bearing washers are packaged in a small bag along with the eight 5/64" thrust bearing balls.*

3. Grease the thrust washer well with MIP RED thrust bearing grease (157) and place the eight 5/64" thrust bearing balls (95) on top of the washer, around the diff screw. Apply more RED thrust bearing grease to the tops of the thrust bearing balls. Place the second thrust washer over the screw and against the thrust bearing balls.

4. Very carefully insert the diff screw, with the thrust bearing assembly installed, into the outdrive (87). Be very careful not to bend or pinch the shim (153) while inserting the diff screw. Pull the threaded end of the diff screw until the thrust bearing assembly rests against the shim and bearing (117) inside of the outdrive.

⚠ IMPORTANT NOTE: Ensure that all eight thrust bearing balls remain in place between the two washers, around the diff screw.

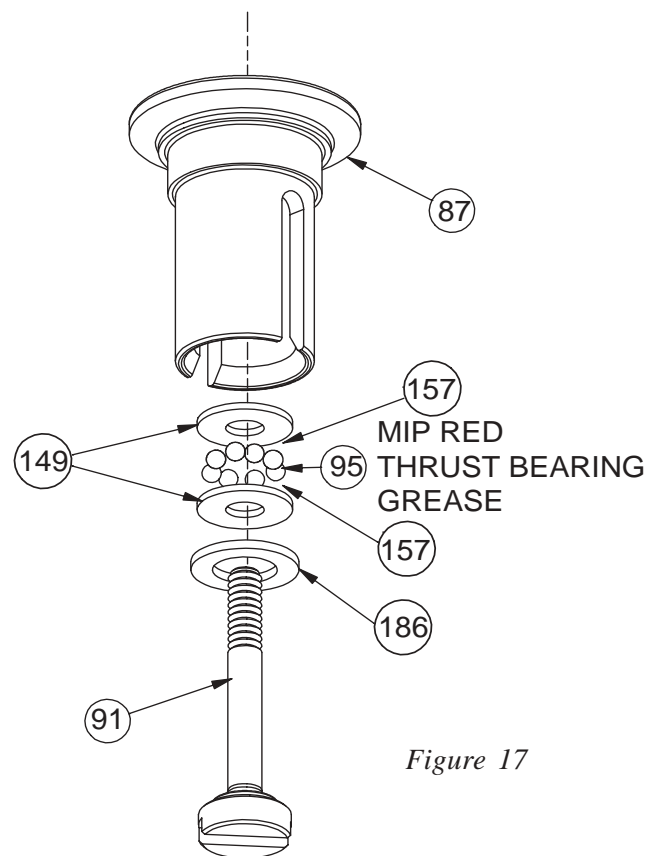
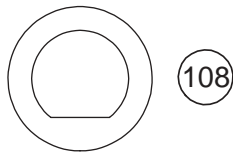

Figure 17

BAG A (Continued)

Step A-18 Diff Drive Ring to Female Outdrive



❑ 1. Locate the smallest of the Allen wrenches, 0.050 (128), and place it through the slot in the outdrive/diff half (87) containing the diff screw (91). Slide the wrench all the way against the screw. By handling the outdrive/diff half with the wrench inserted, the diff screw will be held in place while finishing assembly of the differential.

❑ 2. Apply a small amount of clear diff grease (172) to the outer ridge of the outdrive. Install the remaining diff washer (108), again lining up the flat sections of the outdrive/diff half with the flat sections in the washer.

⚠ IMPORTANT NOTE: Do not glue the diff washers to the outdrive/diff halves. Doing so may not allow the washers to mount flat.

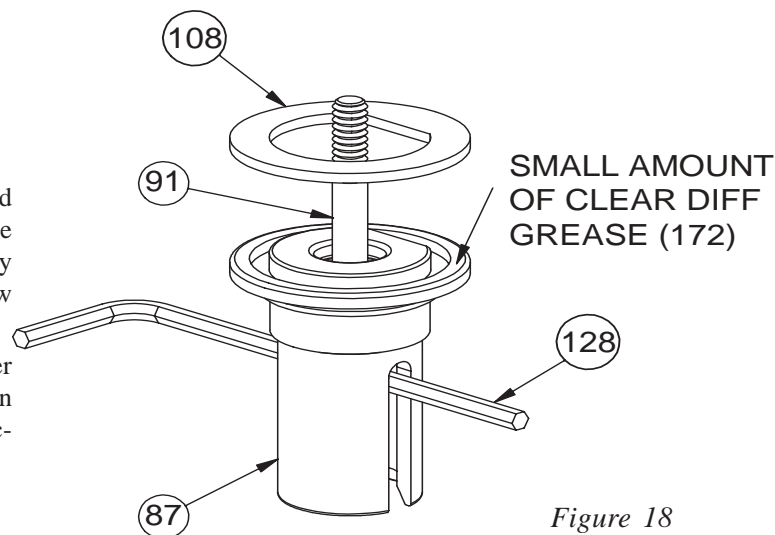

Figure 18

Step A-19 Outdrive Assembly

❑ 1. Carefully replace the Allen wrench (125) with a pen or pencil from the male outdrive (87). The pen will be used to hold the diff nut carrier (27) assembly in the bottom side.

❑ 2. Apply a fairly heavy coat of clear diff grease (172) to the exposed side of the drive/ diff ring (108) on the female outdrive.

❑ 3. While holding the female outdrive with Allen wrench inserted, carefully assemble it to the male outdrive.

❑ 4. Make sure that the slot in the diff screw is lined up with the slot in the female half and then while holding the male half slowly turn the female outdrive until the threads of the diff screw engage on the threads of the 4-40 mini nut (183). Remove the pencil from the male half and thread the two outdrives together until the screw just starts to snug up.

❑ 5. Tighten the diff until the pulley (42) cannot be turned while both of the outdrives are being held firmly. Final diff adjustment should be made after completion of the XXX-4.

When tightening the diff, tighten the screw a little and then "k" the diff a little. Then tighten the screw a little more and "work" the diff again. Continue this until the diff doesn't slip. This ensures that the parts in the diff are properly seated. Refer to tech tips for final adjustment. "Working" the diff is done by rotating the outdrives in opposite directions.

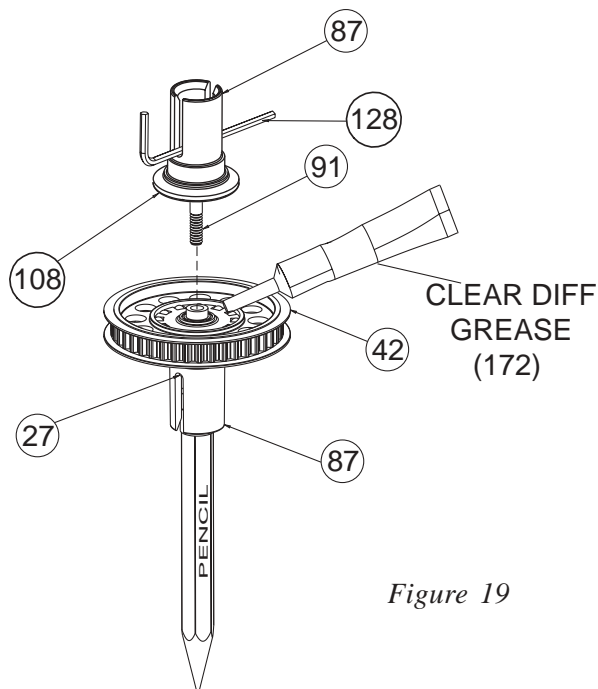
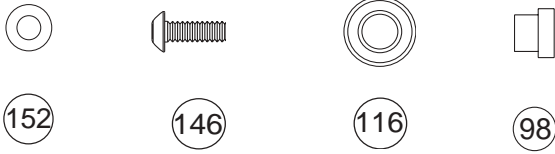

Figure 19

BAG B

Step B-1 Tensioner Arm Assy:



- ❑ 1. Snap a 3/16" x 3/8" bearing (116) into the right side of the idler pulley (44). The bearing will snap past the ridge and stop.
- ❑ 2. Place the idler pulley shaft (98) through the idler pulley from the bearing side.
- ❑ 3. Slide a #4 x .020 washer (152) over the 4-40 x 5/16" button head screw (146).
- ❑ 4. Insert the 4-40 x 5/16" button head screw through the idler pulley and secure it to the belt tensioner arm (110).

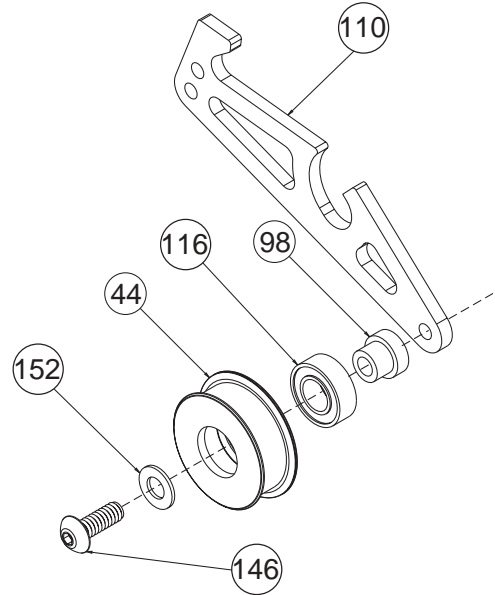



Figure 20

Step B-2 Belt Installation:



****NEVER PINCH THE BELT****

NEVER OVER TIGHTEN THE SCREWS IN THE CHASSIS - Team Losi has designed interlocking features into the XXX-4 chassis when screws are to the point of being snug the parts are held firmly in place.

- ❑ 1. Position the chassis (46) upside-down on your work bench. Insert the belt (77) and pull it through both ends of the chassis.
 - ❑ 2. Pull the belt out, just slightly, through the bottom of the chassis and insert the Steering tunnel (29), tall end forward, into the slot in the front of the chassis. Press into position as indicated in Figure 21.
-  The steering tunnel should now be located in between the belt, with the belt still slightly hanging out of both ends of the car.

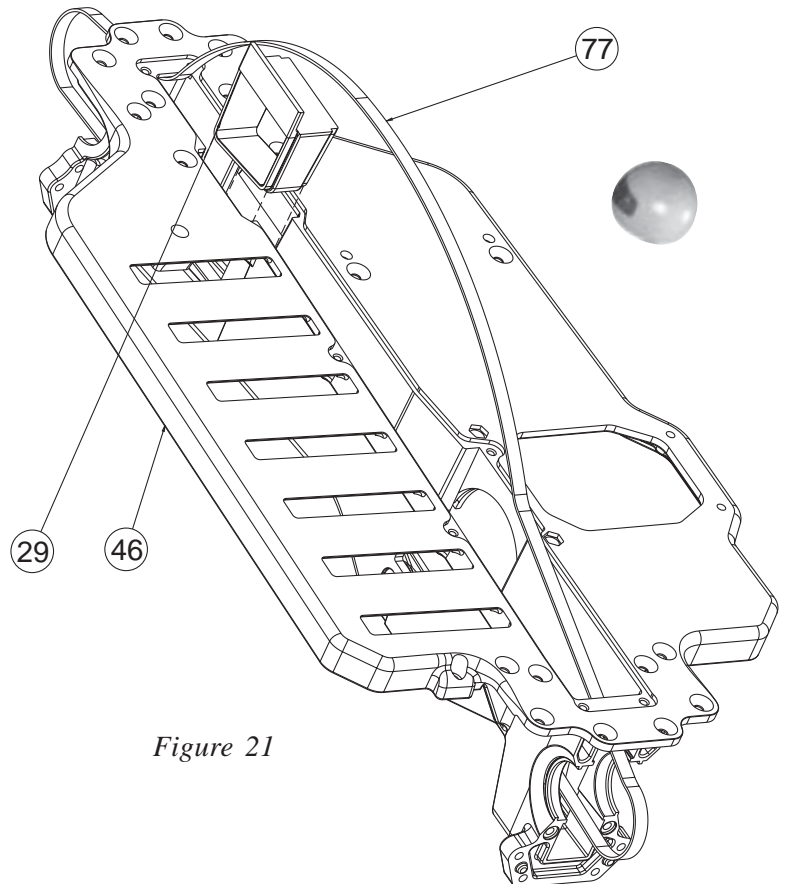
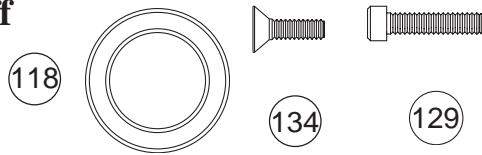

Figure 21

BAG B (Continued)

Step B-3 Front Diff Install:



Note: Use the plastic diff assembly for the front of the XXX-4.

The diff adjustment screw should be facing the drivers left side of the chassis.

1. Slide one 1/2" x 3/4" bearing (118) over each of the outdrive cups (19),(20) with the teflon seal facing away from the diff pulley (42).
2. Pull the belt (77) slightly out of the front of the chassis (46) and install a diff assembly into the slots as indicated in Figure 22. Pull the slack from the belt through the rear of the chassis.
3. Secure the diff assembly by installing the front diff cover (62) with two 4-40 x 1/2" cap head screws (129) through the diff cover into the two counter-bored holes in the chassis.
4. Flip the chassis over and install the two 4-40 x 3/8" flat head screws (134) through the bottom of the chassis into the front diff cover as indicated in Figure 22.

There is a short thread-cutting screw included in the wrench bag. This screw can be used to tap threads in the holes in the main chassis and the bottom of the diff cover. Pre-tapping these holes makes it easier to install the screws during assembly.

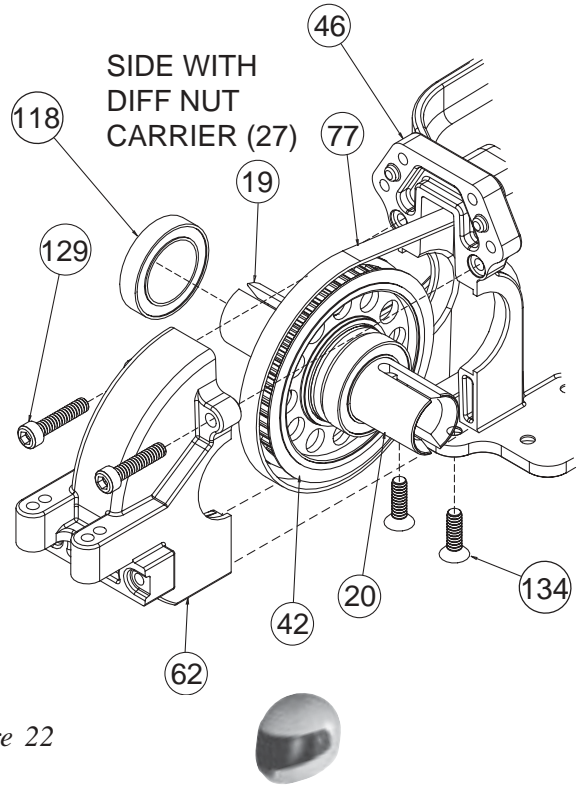
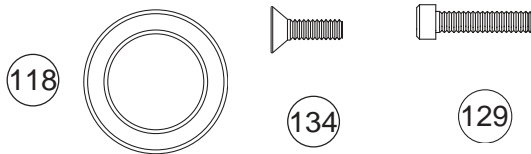

Figure 22

Step B-4 Rear Diff Install:



Note: Use the steel diff assembly for the rear of the XXX-4.

Once again, the diff adjustment screw should be facing the drivers left side of the chassis.

1. Slide one 1/2" x 3/4" bearing (118) over each of the outdrive cups (87),(87) with the teflon seal facing away from the diff pulley (42) on the remaining differential.
2. Spread the belt (77) apart and install the diff assembly into the slots of the chassis (46) as indicated in Figure 23. Once the diff assembly is in place, pull the slack up through the center of the chassis from the top side.
3. Secure the diff assembly by installing the rear diff cover (69) with two 4-40 x 1/2" cap head screws (129) through the diff cover into the counter-bored holes in the rear of the chassis.
4. Flip the chassis over and install the two 4-40 x 3/8" flat head screws (134) through the bottom of the chassis into the rear diff cover as indicated in Figure 23.

There is a short thread-cutting screw included in the wrench bag. This screw can be used to tap threads in the holes in the main chassis and the bottom of the diff cover. Pre-tapping these holes makes it easier to install the screws during assembly.

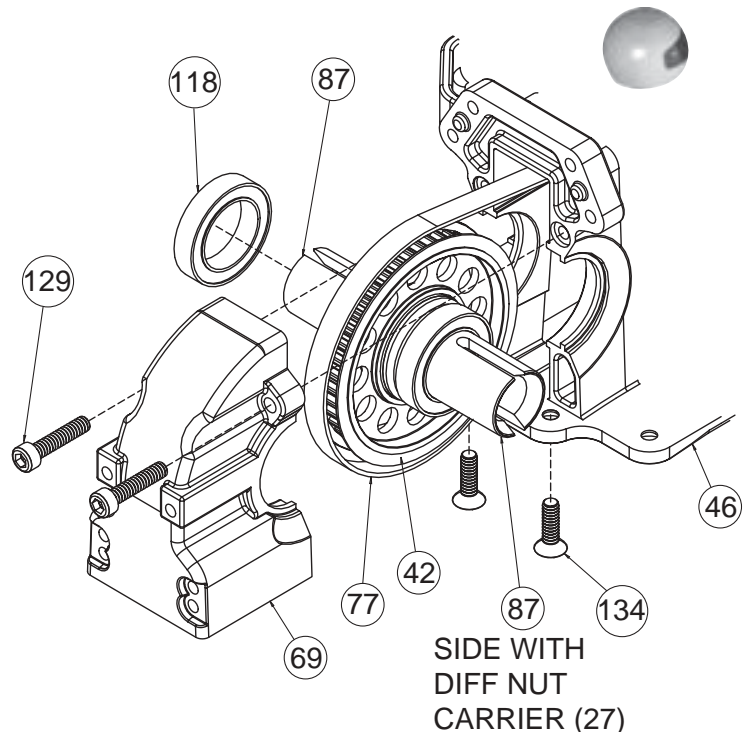

Figure 23

BAG B (Continued)

Step B-5 Slipper Clutch Assembly:

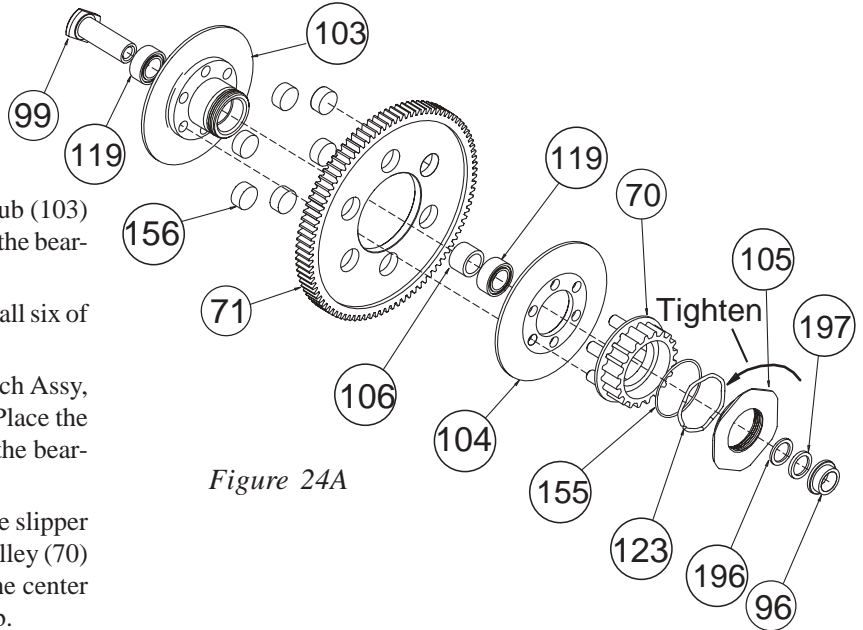
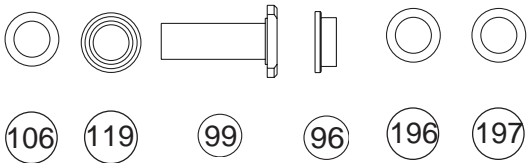
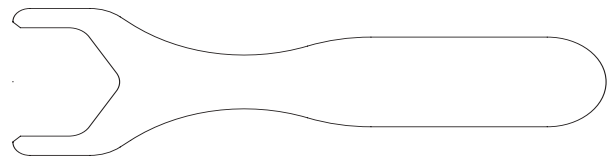

Figure 24A

- ❑ 1. Press a 3/16" x 5/16" bearing (119) into the Slipper Hub (103) from the outside/large face. Slide the Top Shaft (99) through the bearing in the Slipper Hub.
- ❑ 2. Place the Spur Gear (71) onto the slipper hub and place all six of the slipper pucks (156) into the holes in the spur gear.
- ❑ 3. From the "Drive Pulley" (70) side of the Slipper Clutch Assy, slide the Slipper Bearing Spacer (106) over the Top Shaft. Place the second 3/16" x 5/16" bearing into the Slipper Hub.
- ❑ 4. Place the flat face of the Slipper Plate (104) against the slipper pucks in the Spur Gear. Then press the 6 pins of the Drive Pulley (70) through the holes in the Slipper Plate continuing through the center hole of the Spur Gear and into the 6 holes in the Slipper Hub.
- ❑ 5. Insert Slipper Spring Shim (155) followed by the Slipper Wave Spring (123) into the Slipper Drive Pulley and thread the Slipper Flange (105) Counter Clockwise onto Slipper Hub until it is "finger tight". Place one .005 shim (196) and one 0.015 shim (197) on the top shaft next to the bearing. Slide Bushing (96), large side toward Slipper Hub, over Top Shaft.
- ❑ 6. The Slipper Wrench will be used for the final adjustment of the Clutch Assembly at a later step in this manual.



Slipper Wrench (193)

Figure 24B

Step B-6 Slipper Clutch Insert:

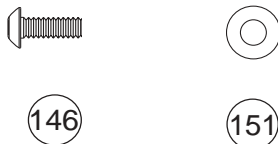



Figure 25

- ❑ 1. Holding the Slipper Clutch Assembly, with thumb and index finger, pull the belt (77) up through the chassis (46) and line up the top shaft (99) with the holes in the chassis.
 - ❑ 2. Place a #4 hardened washer (151) over a 4-40 x 5/16" button head screw (146) and insert it through the left side of the chassis and thread it into the top shaft.
-  You may need to slightly pinch the chassis to install the 4-40 x 5/16" button head screw.
- ❑ 3. Once again, place a #4 hardened washer over a 4-40 x 5/16" button head screw and insert it through the chassis and thread it into the right side of the top shaft.

Leave the right side screw a bit loose until the belt tensioner is installed.



IMPORTANT NOTE: Never pinch the belt as it will result in a shorter life of the belt and cause your vehicle to stop running!

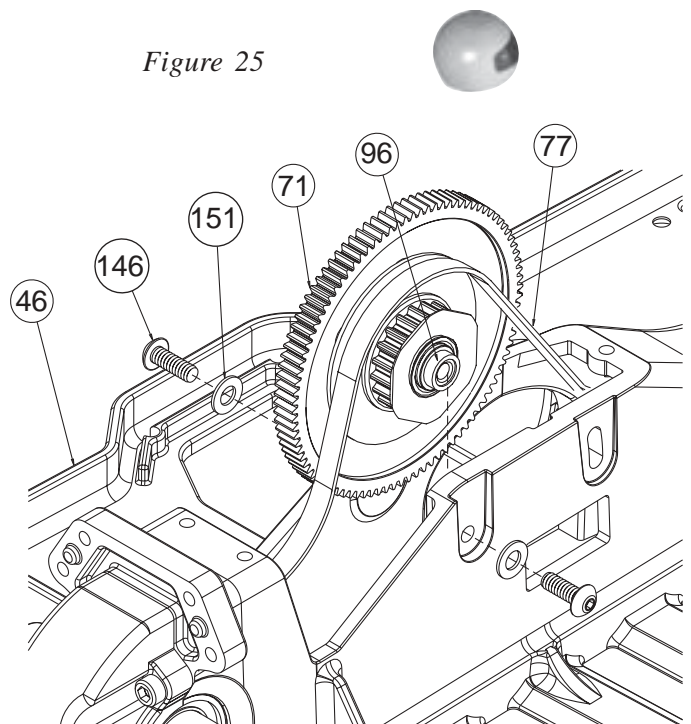

BAG B (Continued)

Step B-7 Tensioner Arm Installation:



(151) (146)

- ❑ 1. Slide the Tensioner Arm Assembly (110) down over the belt (77) and connect the slot in the Tensioner Arm with the Slipper Clutch Assy., Belt Tensioner Bushing (96) as indicated in Figure 26A.
- ❑ 2. Slowly start rotating the Tensioner Arm Assy. around the Belt Tensioner Bushing in a clockwise direction as shown in Figure 26B. While rotating the Tensioner Arm Assembly, slightly pull upward to keep the Tensioner Arm locked and rotating around the Belt Tensioner Bushing. The belt should be positioned between the Slipper Drive Pulley (70) and the Tensioner Arm.
- ❑ 3. Place a #4 hardened washer (151) over a 4-40 x 5/16" button head screw (146).
- ❑ 4. Once you have the belt wrapped around the Slipper Drive Pulley and Belt Tensioner in position, as shown in Figure 26C, secure the Tensioner Assembly by threading the 4-40 x 5/16" screw, with washer through the chassis (46) and into the Tensioner Arm. With the screw about one turn loose, push down on the flat part of the tensioner and set the desired belt tension, tighten the screw.

The belt should move 1/8" (3mm) to 1/4" (7.5mm) up and down for the ideal tension.

Figure 26A

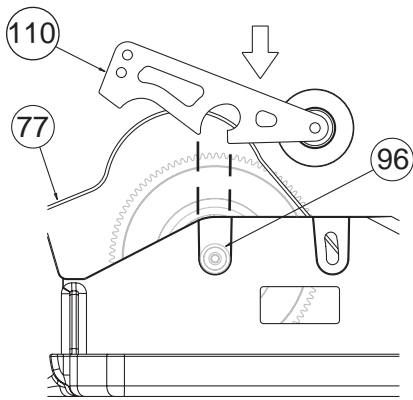

Figure 26B

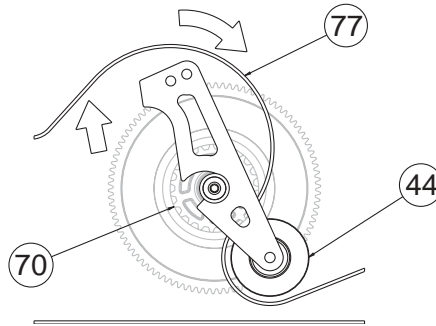
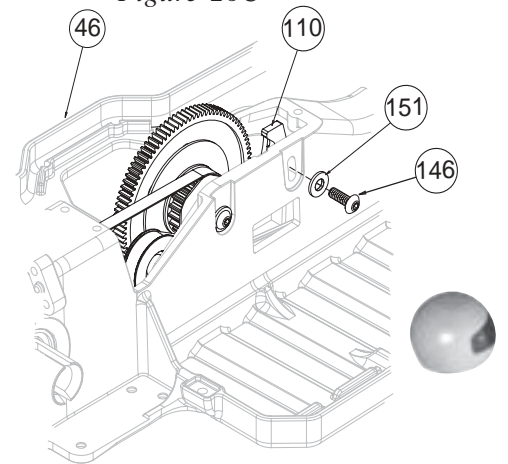

Figure 26C



Step B-8 Bottom Cover Installation:



(145)

- ❑ 1. With the chassis facing upside down, seal the drive train by placing the bottom chassis cover (61) with the flat side towards the bottom of the chassis (46). Secure the bottom chassis cover with seven 2-56 x 3/16" flat head screws (145).

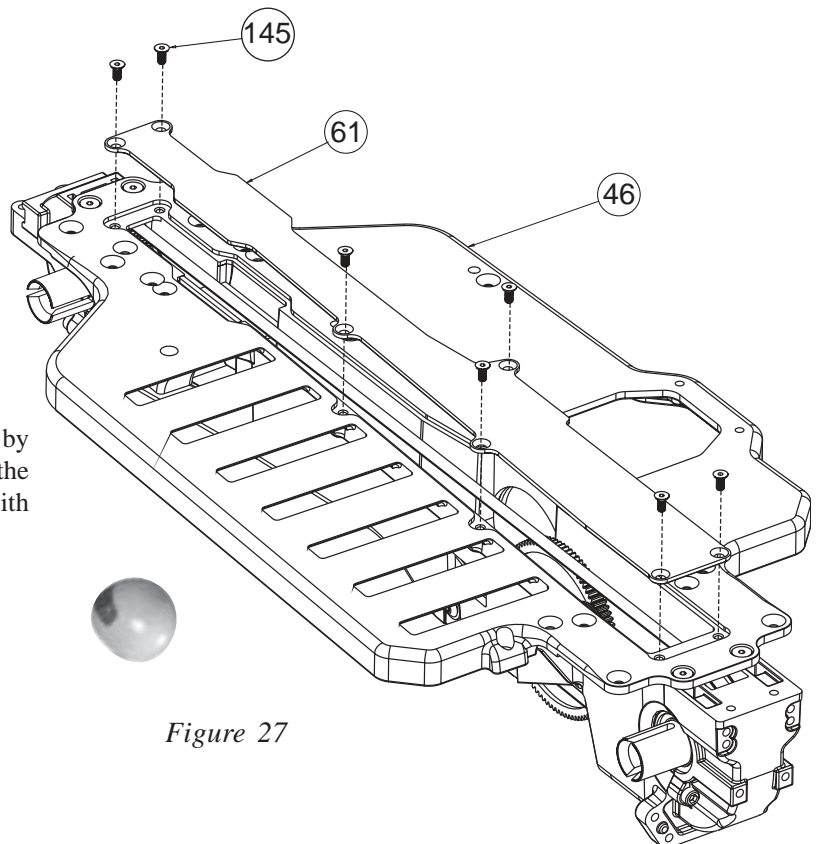
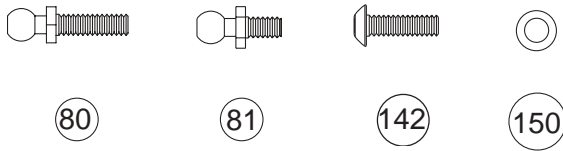

Figure 27

BAG C

Step C-1 Steering Bellcrank Assembly:



Using a medium grade sandpaper (i.e. 500 grit) clean the excess material off the 5mm x 8mm bushings. This will ensure a free working steering assembly.

- ❑ 1. Thread a 3/16" ballstud (81), from the top side, into each of the left (30) and right (31) bellcranks.
- ❑ 2. Insert a 5mm x 8mm bushing (33) into the top and bottom of the left and right bellcranks.
- ❑ 3. Insert the 2 carrier / steering bushings (100), into the bottom side of the draglink (32) and then rest it on the top of the left and right bellcranks.
- ❑ 4. Slide the 3/8" ball stud (80) through the ball stud washer (150) and through the Steering Bushing in the draglink and then thread into the left bellcrank.
- ❑ 5. Thread a 4-40 x 3/8" buttonhead screw (142) through the steering bushing and into the right bellcrank.

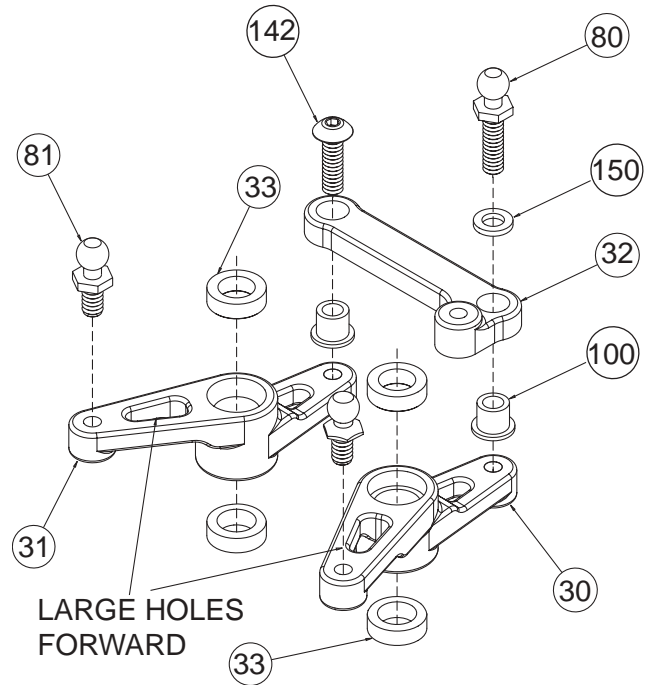
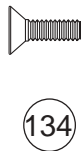

Figure 28

Step C-2 Steering Install:



- ❑ 1. Line up the hex on the steering post (97) with the front hex area on left side of the chassis (46). Press the steering post to the bottom of the hex. Thread a 4-40 x 3/8" flat head screw (134) through the bottom of the chassis and into the steering post.
- ❑ 2. Repeat step 1 for the right side steering post.
- ❑ 3. Slide the draglink assembly from step C-1 through the steering tunnel (29) and then slide the left bellcrank (30) over the steering post on the left side of the chassis.
- ❑ 4. Sliding the right bellcrank (31) over the right steering post will need to be done at the same time as the left bellcrank.

The bellcrank should rotate freely.

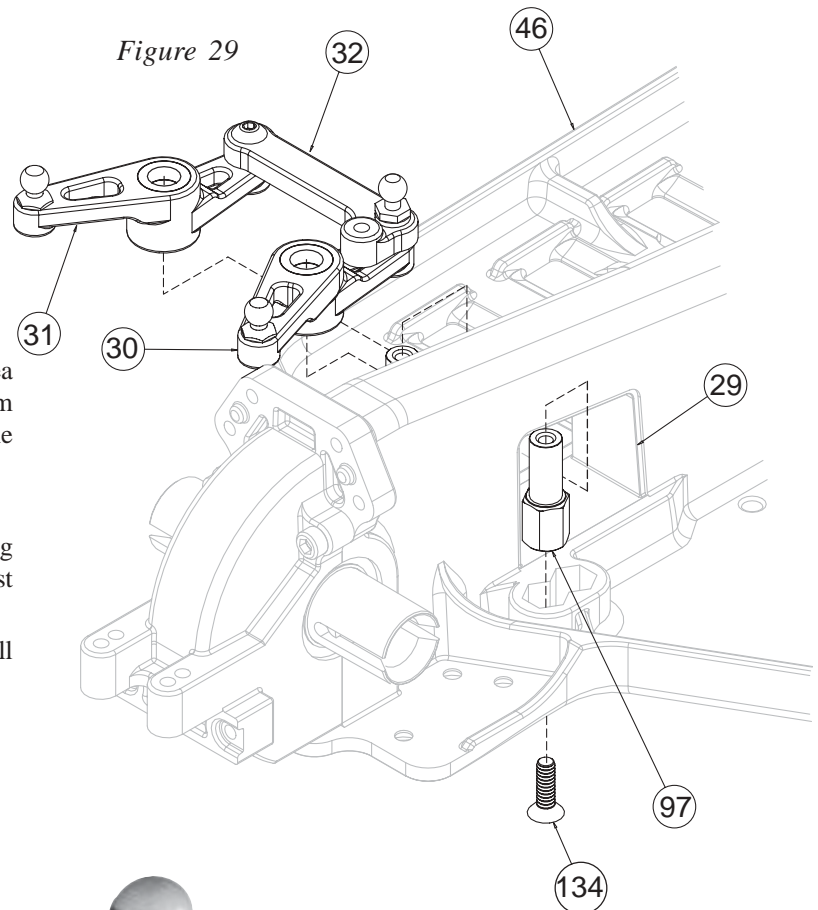

Figure 29

BAG C (Continued)

Step C-3 Front Body Mount Install:



137

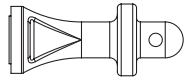

64

- ❑ 1. Thread a 4-40 x 5/8" set screw (137) into a front body mount (64) until it hits the bottom.
- ❑ 2. Thread the body mount into left bellcrank (30).
- ❑ 3. Repeat steps 1 and 2 and thread into the right bellcrank (31).

 *The steering assembly should rotate freely. Be sure that the screws are not too loose but, not too tight.*

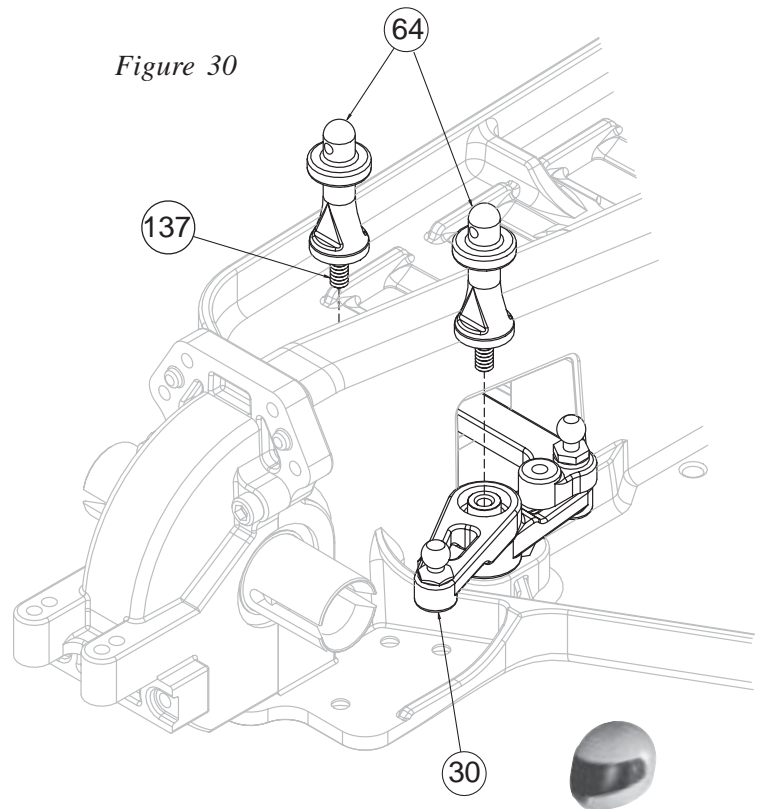

Step C-4 Servo Assembly:

 *All standard servos should use only one silver spring and one gold spring. All hi-torque & high-speed servos will use all three springs.*

- ❑ 1. Using Table 31B (on the following page), determine which servo saver base (36) is required for your servo. If your particular servo is not listed, try using the arm recommended for another servo made by the same manufacturer.
- ❑ 2. Thread a 3/16" ball stud (81) into the outer servo saver arm (39) from the front side as indicated in Figure 31.
- ❑ 3. Plug the servo into the radio system's receiver (*not included*). Make sure that there is power to the receiver, and turn the transmitter on followed by the receiver. Be sure that the trim settings for the steering on your transmitter are set to the center. With the radio system still turned on, attach the servo arm to the output shaft so that the arm is vertical as shown in Figure 31.
- ❑ 4. Turn off your radio, slide one of the two "silver" servo saver springs (111) over the servo arm which is connected to the servo. Fit the second of the "silver" springs over the first spring followed by the "gold" spring (112). The springs should all be pressed against the back of the servo saver base.
- ❑ 5. Press the outer servo arm into the servo saver base. Insert the servo saver washer (40) into the outer servo saver arm. Secure the assembly to the servo with the servo arm screw supplied with the servo.



81

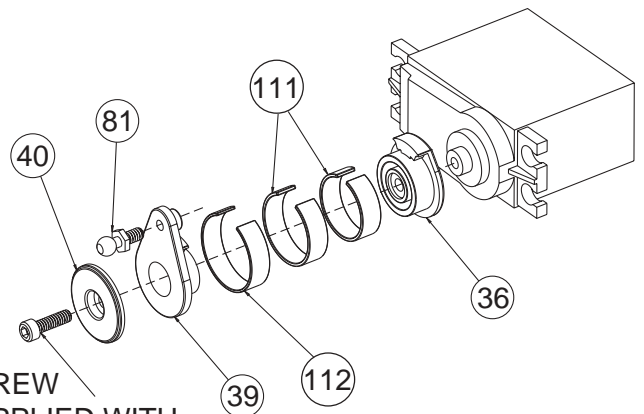

SCREW
SUPPLIED WITH
SERVO

Figure 31

BAG C (Continued)

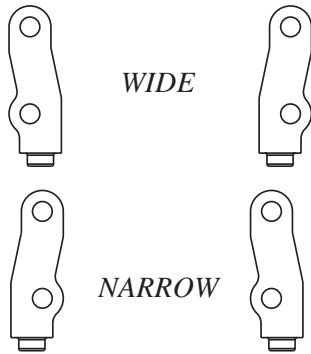

Table 31A

SERVO TYPE	OFFSET	REQUIRED SERVO ARM
AIRTRONICS ALL	NARROW	23
FUTABA S131, S131SH, S148, 23001, S3003, 25101, S9101, S9201, S9304, S9401, S9403	WIDE	25
FUTABA S3401, S9402, S9404, S9450	NARROW	25
HiTech ALL	NARROW	24
JR NES-507, NES-513, NES-517, NES-901, NES-4000, NES-4131, NES-4721, NES-4735, NES-9021, DS-	NARROW	23
JR Z4750, Z8450	WIDE	23
KO PS-702, PS-703, PS-1001, PS-1003	WIDE	23
KO PS-901BH, PS-902	NARROW	23
MULTIPLEX ALL	NARROW	23

Table 31B

Step C-5 Servo Post Assembly:



1. Use Figure 31A and Table 31B to determine how the servo mounting posts (34) and (35) should be attached to the servo (*not included*) in the Wide or Narrow position.
2. Place a #4 washer (151) over each of the four 4-40 x 3/8" cap head screws (131) and attach the servo posts to the servo by threading a screw through the servo mounting ears into the upper and lower holes in each post. **Do not tighten the screws yet!** Just snug them up so that the posts are held in place, but can still be moved from side to side with a little resistance.
3. As shown in Figure 32, you will use the bottom side of the chassis to determine the exact spacing needed for your brand servo. With the screws still loose, push the pins on the servo mounts into the holes in the bottom of the chassis (46). Slide the mounts until the screws are centered on the servo, and tighten as indicated in Figure 32.

 The servo should be as close to centered between the two posts as possible.

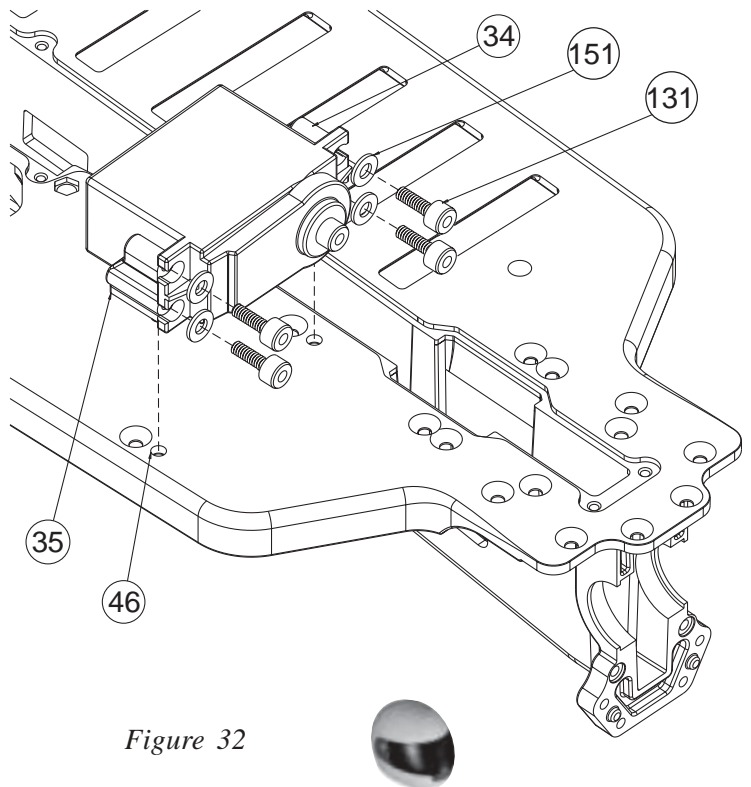

Figure 32

BAG C (Continued)

Step C-6 Servo Install:



134

- ❑ 1. Install the servo into the chassis (46). The pins from both servo mounting posts (34), (35) should fit into the holes and sit flat against the chassis.
- ❑ 2. Secure the servo to the chassis with two 4-40 x 3/8" flat head screws (134).

Figure 33

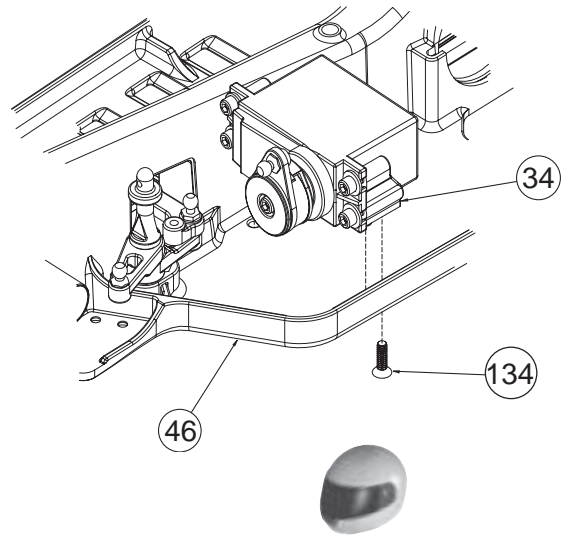

Step C-7



137

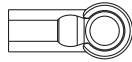

10

- ❑ 1. Thread a short plastic rod end (10) onto each end of the 4-40 x 5/8" threaded rod (137). Tighten both sides equally until the rod is the same length as the one shown in Figure 34B.

Figure 34A

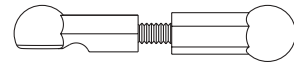
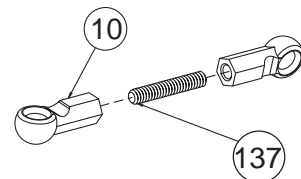
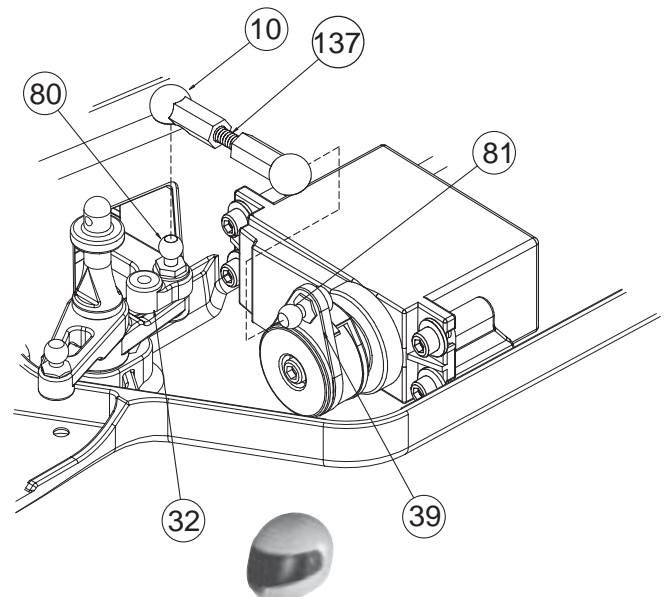

Figure 34B

Step C-8 Servo Link Install:

Figure 35

- ❑ 1. Attach the rod end (10) to the ball stud (80) in the servo saver arm (39) and the other to the ball stud in the drag link (32) as indicated in Figure 35.



BAG D

Step D-1

Front Inner Pivot Install



134

- 1. Install the front left inner pivot block (47) by threading two 4-40 x 3/8" flat head screws (134) through the bottom of the chassis (46) into the pivot block as indicated in Figure 36. Repeat for the right front inner pivot block (48).

The left & right inner pivots are marked with "L" & "R".

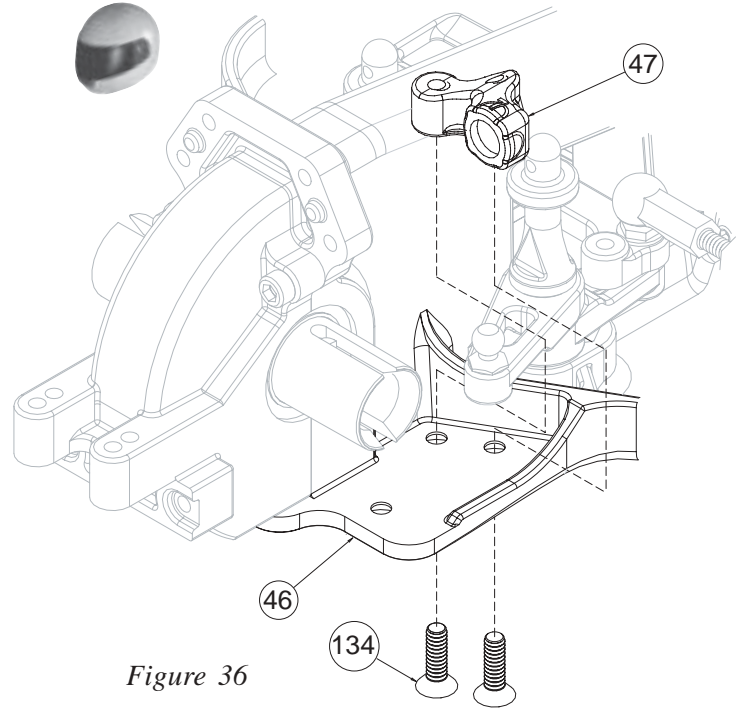

Figure 36

Step D-2

Front Arm Install



135

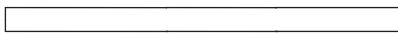

101



195

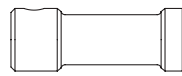

194

Figure 37A



ASSEMBLE MAIN BLOCK
IN THIS DIRECTION

- 1. Slide a 1/8" inner hinge pin (101) through the larger holes of each of the two front arms (53) also passing through the Hinge Pin Retainer (194).

- 2. Position the arm so that the shock mount hole faces the front of the chassis (46). Place one pivot ball (49) on the rear of each hinge pin. Insert the arm into the inner front pivot block (47) L, (48) R. Capture the front arms by placing the front main block (50) marked with "7.5F" onto the inner hinge pins as shown in the illustration in Figure 37B. Secure the front main block by threading two 4-40 x 1/2" flat head screws (135) through the main block into the holes in the front diff cover (62).

- 3. After securing the front main block, thread a 5-40 x 1/8 Set Screw (195) into the Hinge Pin Retainer and tighten to secure the hinge pin.

Note: The arm should rotate freely on the hinge pin and not in the front main block or the pivot balls. If the arm does not pivot freely, use a small file to remove a small amount of material from the arm where the hinge pin retainer rests against it.

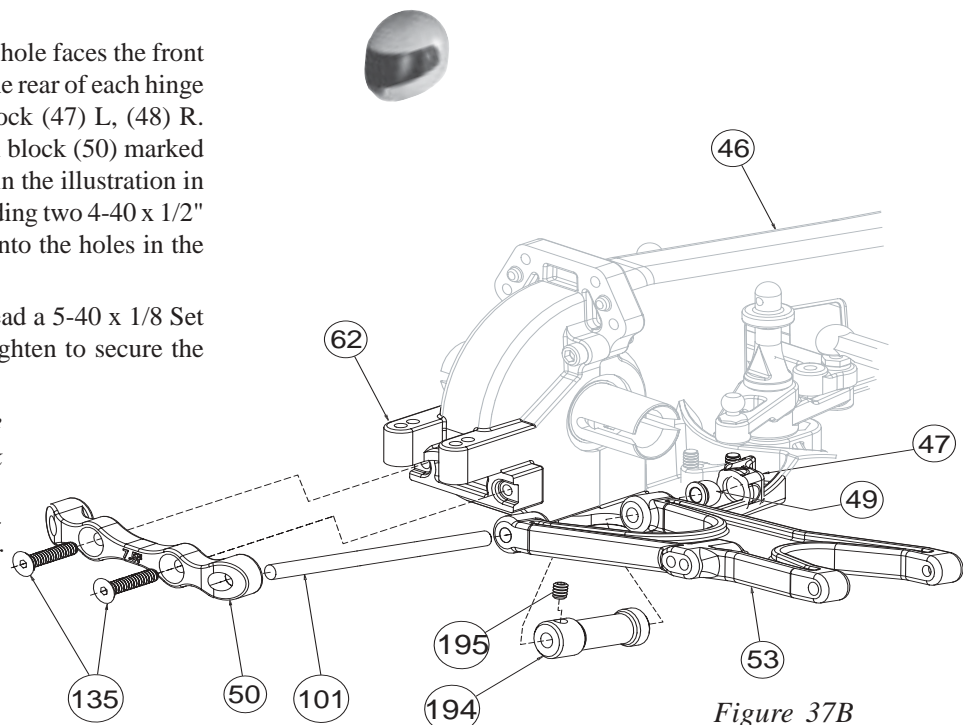

Figure 37B

BAG D (Continued)

Step D-3

Front Shock Tower



130



182



107

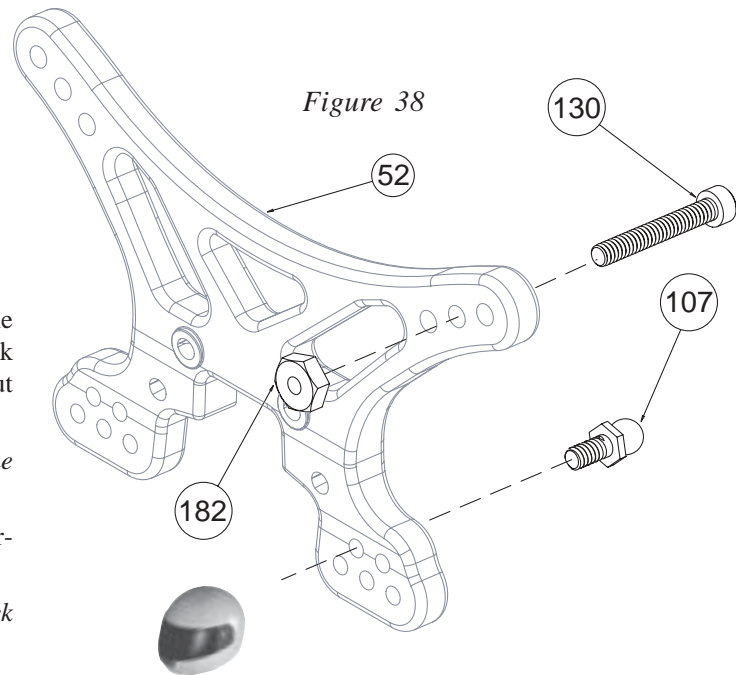

Figure 38

- 1. Insert a 4-40 x 3/4" cap head screw (130) on either side of the shock tower (52) through the middle hole on the top of the shock tower. Secure the screws to the tower by threading a 4-40 zinc nut (182) over each screw and tightening.

The screws should extend away from the recessed area in the front shock tower.

- 2. Thread a short neck ball stud (107) into the inner and uppermost of the lower five holes on either side of the shock tower.

The ball studs should face the recessed area in the front shock tower.

Step D-4

Front Shock Tower Install



129

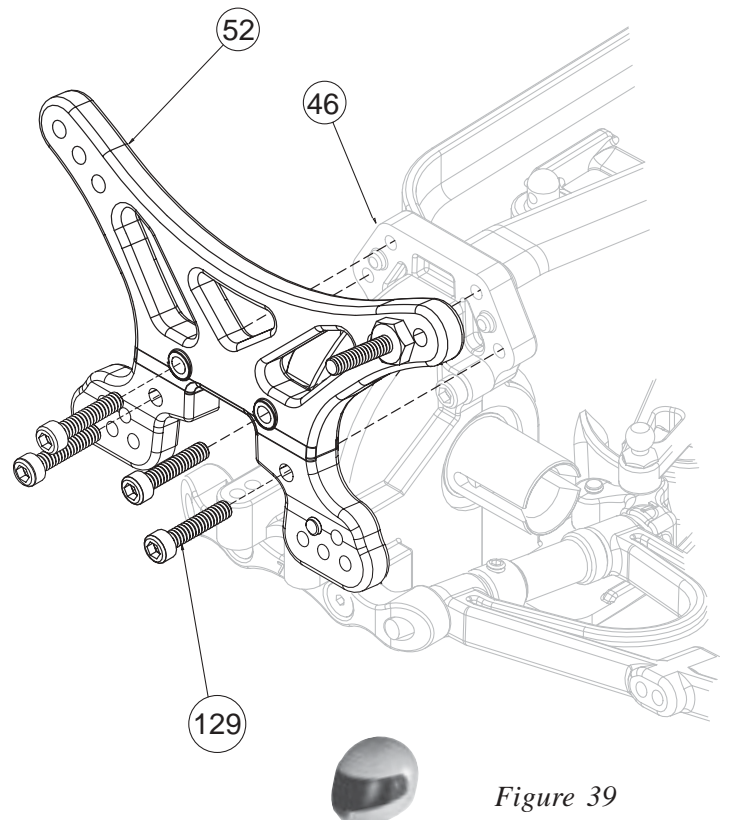

Figure 39

- 1. Attach the front shock tower (52) to the front of the chassis (46) with four 4-40 x 1/2" cap head screws (129). The screws thread into the top-most and bottom-most holes, surrounding the posts, which stick out of the front of the chassis. The shock tower should interlock with the posts on the chassis.

There is a short thread-cutting screw included in the wrench bag. This screw can be used to tap threads in the holes in the main chassis. Pre-tapping these holes makes it easier to install the screws during assembly.

BAG D (Continued)

MIP CVD TABLE

*NOTE: See Table 40 for part numbers and name of all items referred to in the MIP CVD kit for the front of the XXX-4.

MIP CVD KIT FRONT XXX-4			
PART #	NAME	PART #	NAME
114A	Coupling	114F	Bearing Spacer
114B	Solid Pin	114G	Roll Pin
114C	Set Screw	114H	Hex Adapter
114D	Axle	114J	8-32 Locknut
114E	CVD Bone		

Table 40

Step D-5 CVD Axle Assembly



1. Apply a thin coat of red MIP thrust bearing/ assembly grease (157), (from the white tube), to the outside of the CVD coupling (114A). Insert the greased CVD coupling into the large hole in the CVD Axle (114D) so that the cross-hole in the coupling can be seen through the slots in the axle.
2. Place the CVD bone (114E) over the CVD axle. Align the holes in the CVD bone with the hole in the CVD coupling. Secure all three parts by inserting a 1/16" x 7/16" (solid) pin (114B) through the holes in the CVD bone, the slots in the CVD axle, and the hole in the CVD coupling.
3. Apply a small amount of Thread-lock compound (158), in the black tube, to the set screw (114C) before installing it. Center the pin in the CVD bone and secure it by threading a 4-40 x 1/8" set screw into the end of the CVD coupling.
4. Repeat Steps 1-4 for the second CVD assembly.

Apply the enclosed Thread-lock to the set screw before threading it into the CVD coupling. If Thread-lock is not used, the set screw will loosen during operation. This will cause your car to stop running.

Figure 41

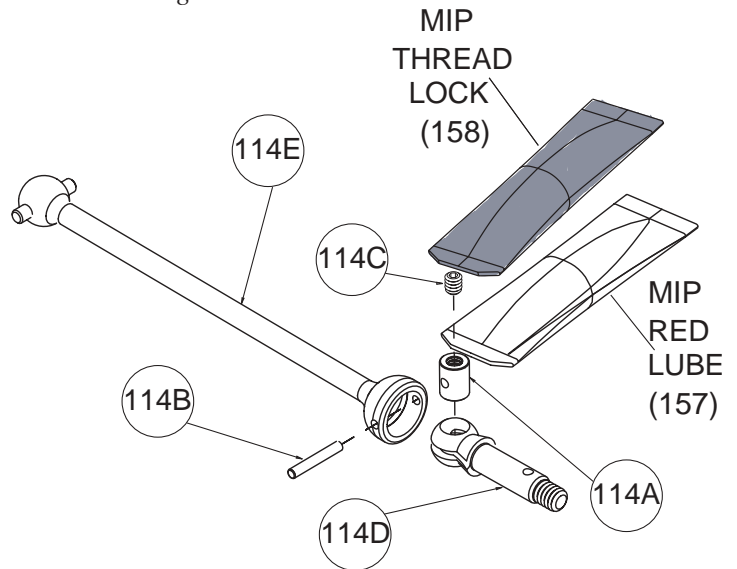

Step D-6 CVD Axle to Spindle Assembly



1. Thread a 1/4" ball stud (92) through a 0.060 spacer (13) through the top side of the left spindle arm (16) and into a 4-40 x 3/16 mini nut (183), as shown in Figure 42A.
2. Install a 3/16 x 3/8 bearing (116) with the teflon seal facing out, in the back side of the left spindle. From the front side install the bearing spacer (114F) followed by another 3/16 x 3/8 bearing teflon seal facing out.
3. Insert the assembled MIP CVD (114D) through the bearings in the left spindle. Install the MIP hex adapter (114H) over the axle with the cut out section facing away from the bearing. Align the holes in the hex adapter and axle and insert a 1/16 x 5/16 (roll) pin (114G) through the two until flush on both sides.
4. Repeat steps 1-4 for the right spindle assembly.

Figure 42A

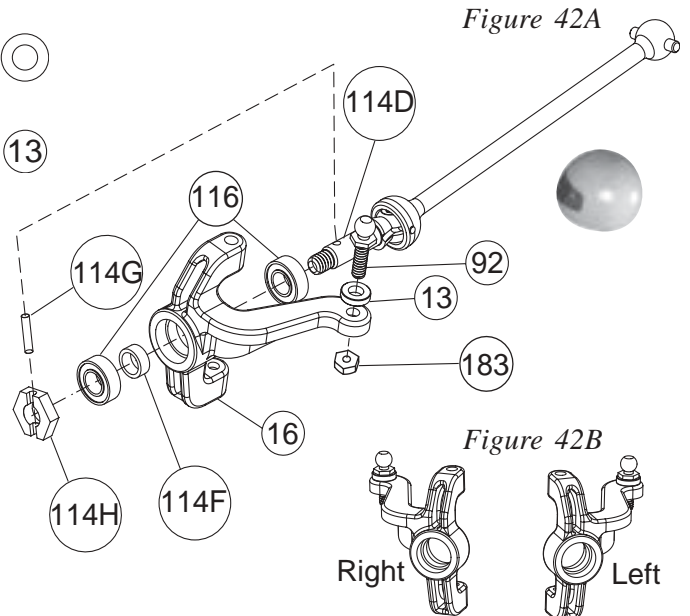
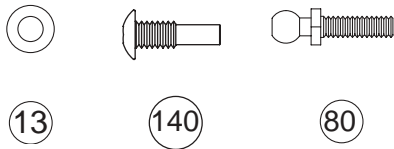

Figure 42B

Right Left

BAG D (Continued)

Step D-7 Spindle To Spindle Carrier



1. Attach the spindle (16) to the spindle carrier (18) by sliding the CVD bone (114E) through the spindle carrier as illustrated in Figure 43. Line up the holes in the spindle and the spindle carrier. Thread a kingpin screw (140) through the spindle and into the spindle carrier from the top and bottom.

2. Place a 0.060 washer (13) over a 4-40 x 3/8 ball stud and thread into the top of the left spindle carrier.

3. Repeat Steps 1-2 for the right spindle and carrier assembly.

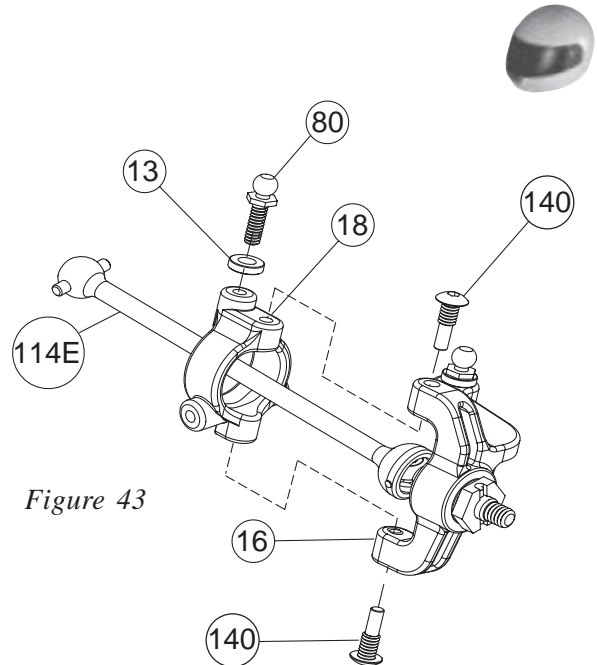
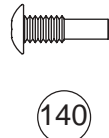

Figure 43

Step D-8 Front Arm to Spindle & Carrier



1. Attach the left spindle and carrier assembly to the left front arm (53) by aligning the holes in the spindle carrier (18) with the holes in the front arm. Thread a kingpin screw (140) through the outer holes in the front and back of the arm, and into the spindle carrier. Tighten the screws.

You may have to un-tighten the screws 1/4 turn to allow free movement of the spindle carrier on the arm.

3. Repeat Step 1 for the right arm to spindle carrier assembly.

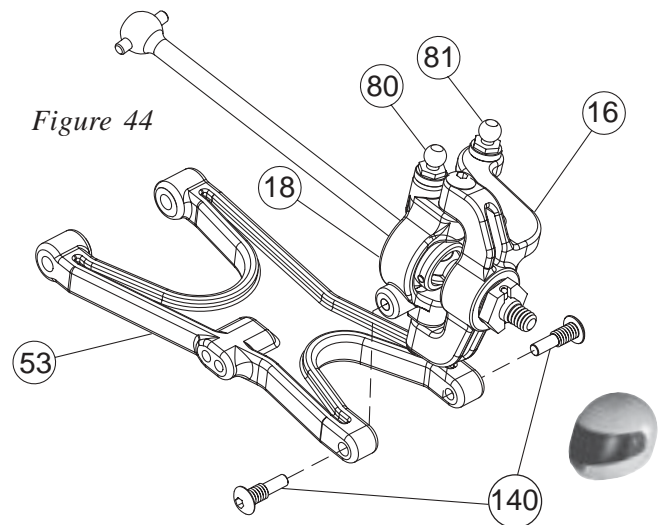
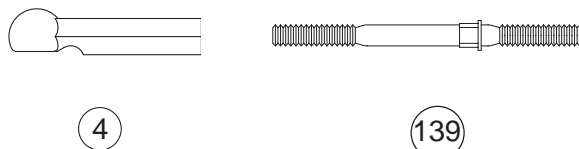

Figure 44

Step D-9



1. Thread a plastic rod end (4) onto each end of a 1.625" turnbuckle (139). Tighten both rod ends (4) equally until the rod is the same length as the rod in Figure 45B. Make two of these tie rod assemblies.

Each end of the turnbuckle is threaded opposite. The end closest to the square shoulder has right-hand threads, the other has left-hand threads. This allows the length of the rods, once installed, to be adjusted without removing them.

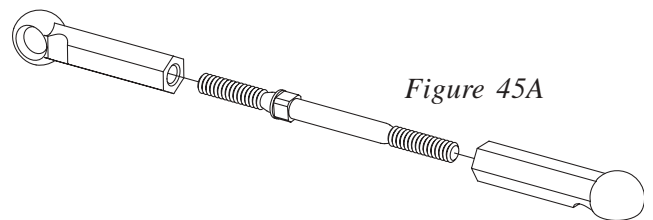

Figure 45A

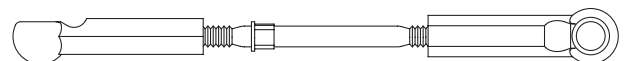

Figure 45B

BAG D (Continued)

Step D-10 Turnbuckle - Front Shocktower to Spindle Carrier



185

1. Place a "foam thing" (185) over the ball stud (80) located in the top of the spindle carrier (18). Place a second "foam thing" over the ball stud (107) located in the shocktower (52).

Assure that the drive end of the CVD bone is inserted in the outdrive before attaching the turnbuckle.

2. Snap the end, closest to the shoulder, of the turnbuckle assembly to the ball stud in the spindle carrier. Snap the other end to the ball stud in the shock tower.

3. Repeat 1-2 to attach the other turnbuckle assembly to the right spindle assembly.

Assure that the shoulder of the turnbuckle is located towards the outside of the chassis for easier adjustment later.

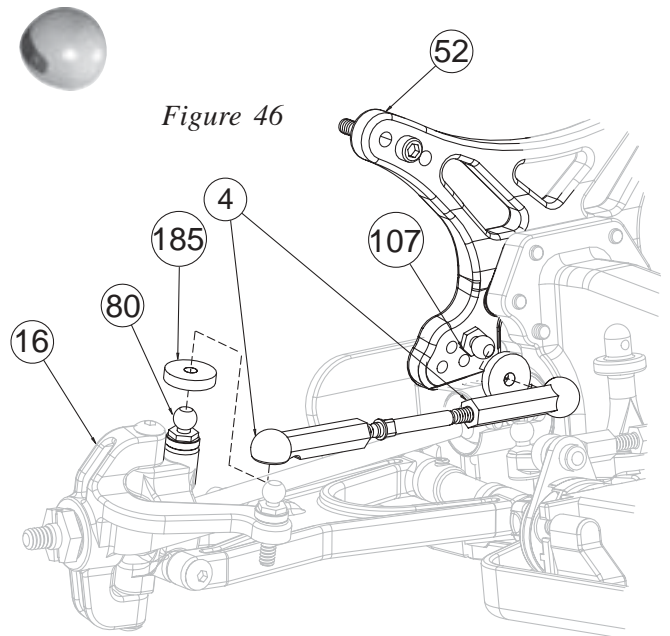

Step D-11



4

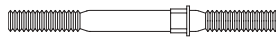

141

1. Thread a plastic rod end (4) onto each end of a 1.375" turnbuckle (141). Tighten both rod ends equally until the rod is the same length as the assembled rod in Figure 47B. Make two of these assemblies.

Each end of the turnbuckle is threaded opposite. The end closest to the square shoulder has right-hand threads, the other has left-hand threads. This allows the length of the rods, once installed, to be adjusted without removing them.

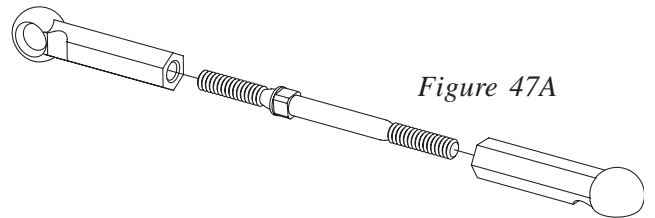

Figure 47A

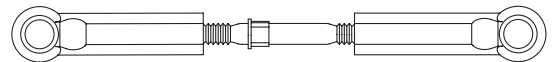

Figure 47B

Step D-12 Turnbuckle -Spindle To Bellcrank

1. Snap the end, closest to the shoulder, of the turnbuckle assembly to the 1/4" ball stud (92) in the left spindle. Snap the other end to the 3/16" ball stud (81) in the left bellcrank.

2. Repeat steps 1-2 to attach other turnbuckle to the right side spindle and bellcrank.

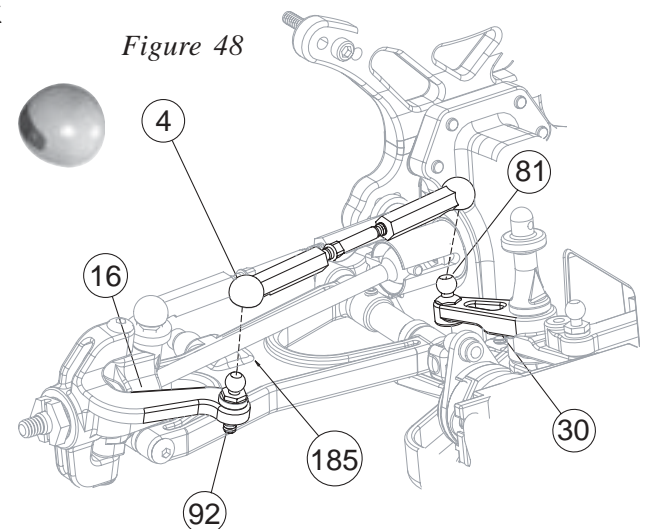

Figure 48

BAG E

Step E-1 Rear Inner Pivot Install



134

1. Install left rear inner pivot block (54) by threading two 4-40 x 3/8" flat head screws (134) through the bottom of the chassis (46) into the pivot block as indicated in Figure 49. Repeat for the right rear inner pivot block (55).

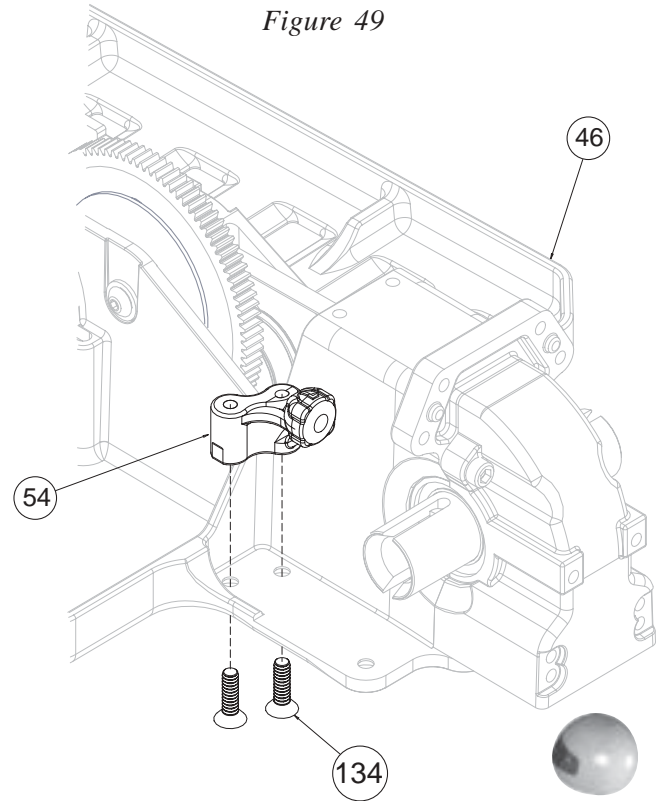

Step E-2 Rear Arm Install



135

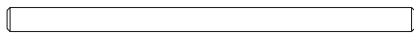

102

1. Slide an inner hinge pin (102) through each of the two rear arms farthest away from the shock mounting hole.

 Before you tighten the main block it may be necessary to slightly loosen the screws in the inner pivots about 1 full turn. Once this is done, tighten the main block, followed by tightening the inner pivots. This will ensure you get the correct pin angle in the arms

2. Insert the left arm (12) (Arms labeled "L" and "R") into the left inner rear pivot block (54). Repeat for the right arm (11) and capture the rear arms by placing the rear main block (57) onto the inner hinge pins as shown in the illustration in Figure 50B. Secure the rear main block by threading two 4-40 x 1/2" flat head screws (135) through the main block into the upper holes in the rear diff cover (69).

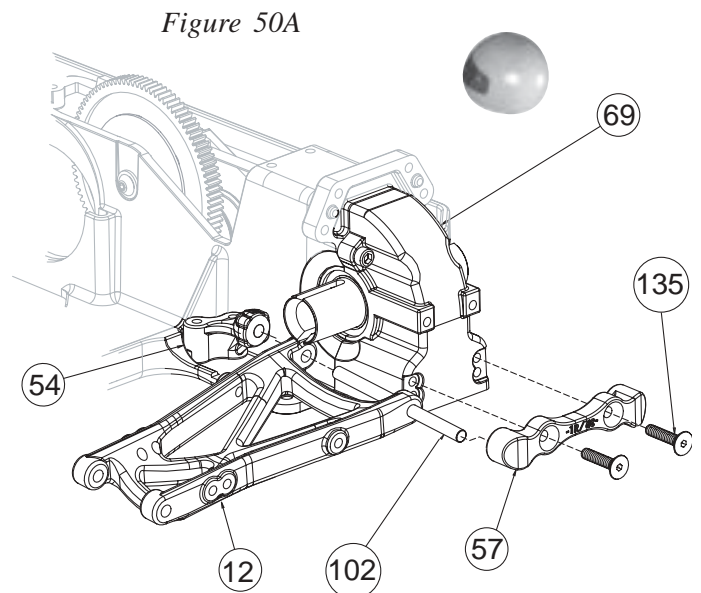

Figure 50B



ASSEMBLE MAIN BLOCK
IN THIS DIRECTION

BAG E (Continued)

Step E-3 Rear Shock Tower

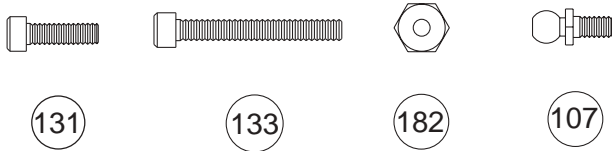

- ❑ 1. Thread a short head ball stud (107) on each side of the shock tower into the inside hole in the lowest set of holes.
- ❑ 2. Insert a 4-40 x 7/8" cap head screw (133), one on either side of the shock tower (58) into the middle hole in the upper set of holes. Secure the screws to the tower by threading a 4-40 zinc nut (182) over each screw and tightening.

 *The screws should extend towards the recessed area in the rear tower and face towards the front of the chassis.*

- ❑ 3. Install the rear body mount (65) by aligning the mounting hole in the body mount with the hole in the middle of the shock tower. Secure the body mount by threading a 4-40 x 3/8" cap head screw (131) through the shock tower and into the body mount as indicated in Figure 51.

- ❑ 4. Install the rear wing mounts (63) by aligning the mounting holes in the wing mounts with the holes to the side of the shock tower. Secure the wing mounts by threading a 4-40 x 3/8" cap head screw (131) through the shock tower and into the top and bottom of the wing mounts as indicated in Figure 51 (Right side wing mount installation not shown).

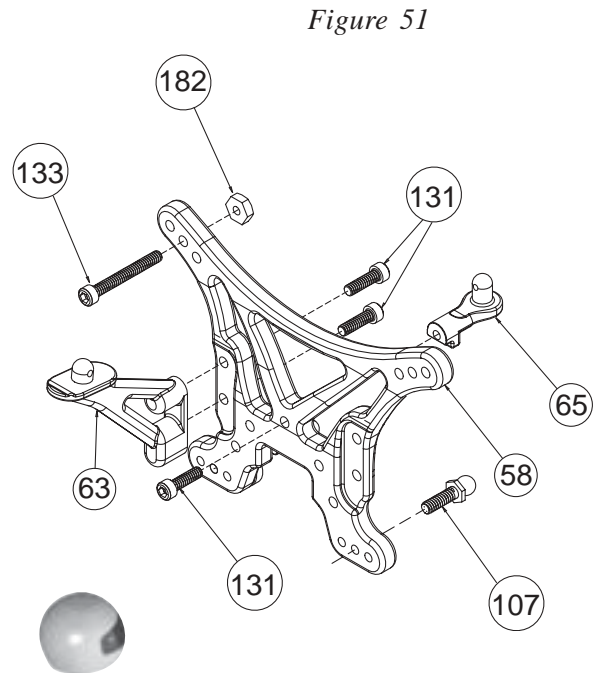
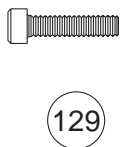



Figure 51

Step E-4 Rear Shock Tower Install



- ❑ 1. Attach the rear shock tower (58) to the rear of the chassis (46) with four 4-40 x 1/2" cap head screws (129). The screws thread into the top-most and bottom-most holes surrounding the posts, which stick out of the rear of the chassis. The shock tower should interlock with the posts on the chassis.

 *There is a short thread-cutting screw included in the wrench bag. This screw can be used to tap threads in the holes in the main chassis. Pre-tapping these holes makes it easier to install the screws during assembly.*

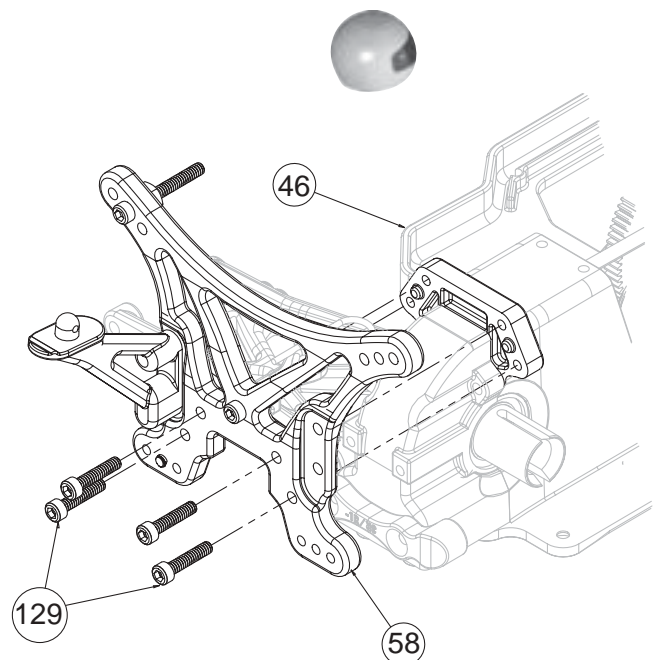
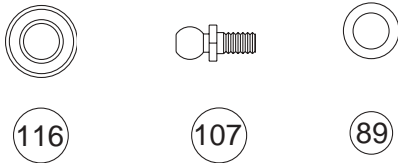

Figure 52

BAG E (Continued)

Step E-5 Rear Hub Assembly



- ❑ 1. Thread a short head ball stud (107) into the inside hole of the rear hub (23) as indicated in Figure 53.
- ❑ 2. Insert a 3/16" x 3/8" bearing (116) with the teflon seal facing out, into the back-side of the hub carrier(23). From the front-side, insert a bearing spacer (89) as illustrated in Figure 53. Capture the spacer with a 3/16" x 3/8" bearing again with the teflon seal facing out. Make two of these assemblies.

Figure 53

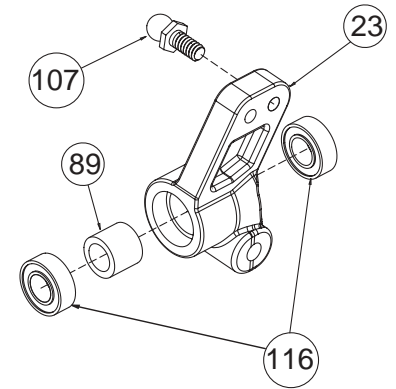

MIP CVD TABLE

*NOTE: See Table 54 for part numbers and name of all items referred to in the MIP CVD kit for the rear of the XXX-4.

MIP CVD KIT REAR XXX-4			
PART #	NAME	PART #	NAME
113A	Coupling	113E	CVD Bone
113B	Solid Pin	113F	Roll Pin
113C	Set Screw	113G	8-32 Locknut
113D	Axle		

Table 54

Step E-6 CVD Dogbone/Axle

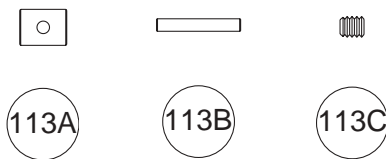

- ❑ 1. Apply a thin coat of red MIP RED thrust bearing/ assembly grease (157), (from the white tube), to the outside of the CVD coupling (113A). Insert the greased CVD coupling into the large hole in the CVD Axle (113D) so that the cross-hole in the coupling can be seen through the slots in the axle.
- ❑ 2. Place the CVD bone (113E) over the CVD axle. Align the holes in the CVD bone with the hole in the CVD coupling. Secure all three parts by inserting a 1/16" x 7/16" (solid) pin (113B) through the holes in the CVD bone, the slots in the CVD axle, and the hole in the CVD coupling.
- ❑ 3. Apply a small amount of Thread-lock compound (158), in the black tube, to the 4-40 x 1/8" set screw (113C) before installing it. Center the pin in the CVD dogbone and secure it by threading the set screw into the end of the CVD coupling.
- ❑ 4. Repeat Steps 1-4 for the second CVD assembly.

Figure 55

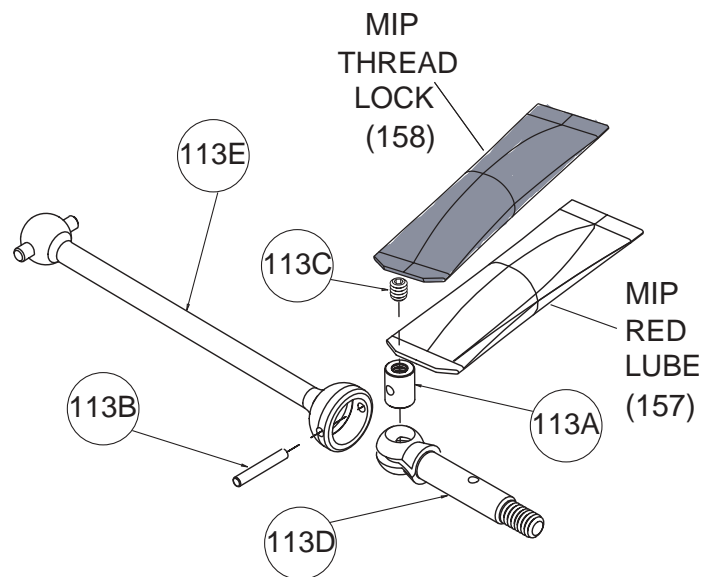

 Apply the enclosed Thread-lock to the set screw before threading it into the CVD coupling. If Thread-lock is not used, the set screw will loosen during operation. This will cause your car to stop running.

BAG E (Continued)

Step E-7 CVD Dogbone/Axle to Rear Hub

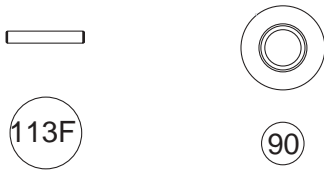

1. Slide the CVD through the 3/16" x 3/8" bearing (116) from the backside of the hub (23) until the shoulder of the axle (113D) stops at the bearing. Slide the axle washer (90) over the axle up against the outside bearing. Secure the axle and washer with a 1/16" x 5/16" (roll) pin (113F) through the cross hole in the axle. The pin should be centered in the axle. Repeat for the right rear hub (24) assembly.

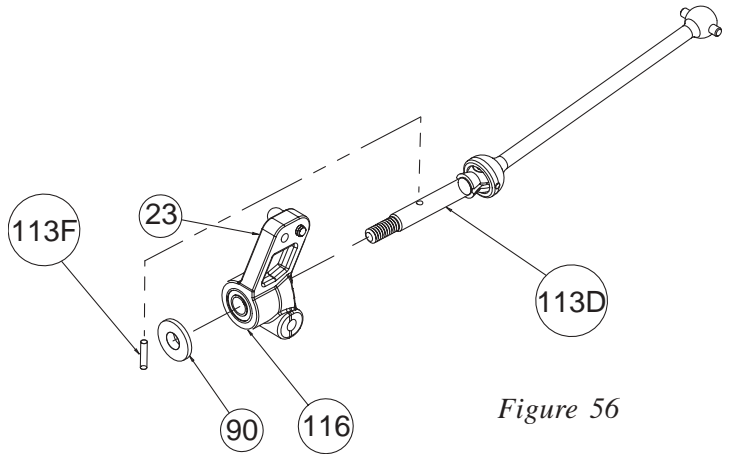
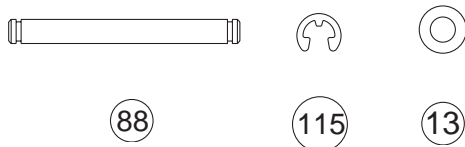

Figure 56

Step E-8 Rear Hub Install



1. Attach the left rear hub (23) assembly to the left rear arm (12) by aligning the holes in the rear hub (23) with the holes in the rear arm. Place one 0.060 rear hub spacer (13) on either side of the hub. Insert a 1/8" x 1.350" hinge pin (88) through the arm into the hub as indicated in Figure 57.

2. Secure the hinge pin by placing an e-clip (115) on each side of the hinge pin.

3. Repeat Steps 1-2 for the remaining right rear arm (11) and right rear hub (24) assembly.

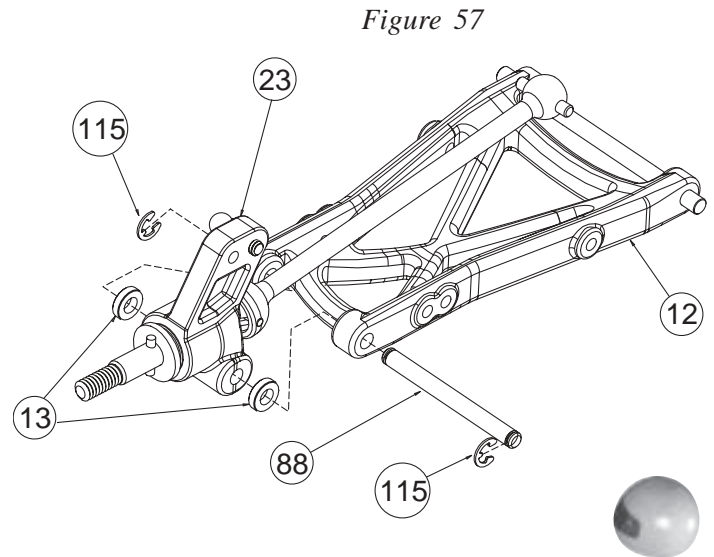



Figure 57

Step E-9



1. Thread a plastic rod end (4) onto each end of a 1.375" turnbuckle (141). Tighten both rod ends equally until the rod is the same length as the assembled rod in Figure 58B. Make two of these assemblies.

 Each end of the turnbuckle is threaded opposite. The end closest to the square shoulder has right-hand threads, the other has left-hand threads. This allows the length of the rods, once installed, to be adjusted without removing them.

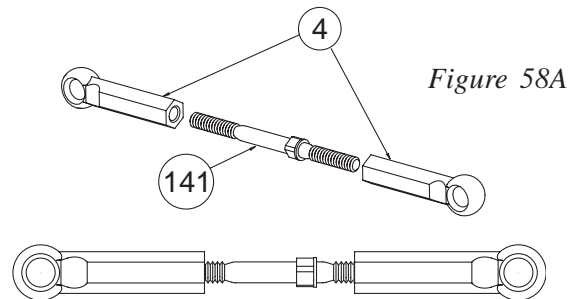

Figure 58A

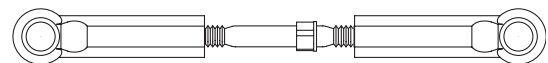



Figure 58B

BAG E (Continued)

Step E-10 Turnbuckle - Rear Shock tower to Rear hub

❑ 1. Place a "foam thing" (185) over the ball stud (107) in the rear hub (23). Place a second "foam thing" over the ball stud in the rear shock tower (58).

 *Assure that the drive end of the CVD bone is inserted in the outdrive before attaching the turnbuckle.*

❑ 2. Snap the end closest to the shoulder of the turnbuckle assembly to the ball stud in the left rear hub. Snap the other end to the ball stud in the rear shock tower. Repeat Steps 1-2 to attach the other turnbuckle assembly to the right rear hub (24) assembly.

 *Assure that the shoulder of the turnbuckle is located towards the outside of the chassis for easier adjustment later.*

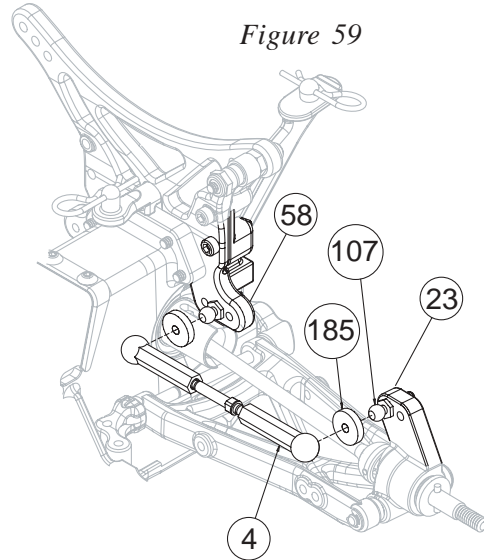

Step E-11 Battery Post Install



131

❑ 1. Install the battery mount posts (68) to the chassis (46), as shown, by placing the square base of the post in the countersunk pockets on the drivers right side of the chassis.

❑ 2. Thread a 4-40 x 3/8" cap head screw (131) through the bottom of the chassis into each of the battery mounting posts and tighten.

❑ 3. One Body Clip (124) will be inserted into the holes on the top of each Battery Post at a later step in this manual.

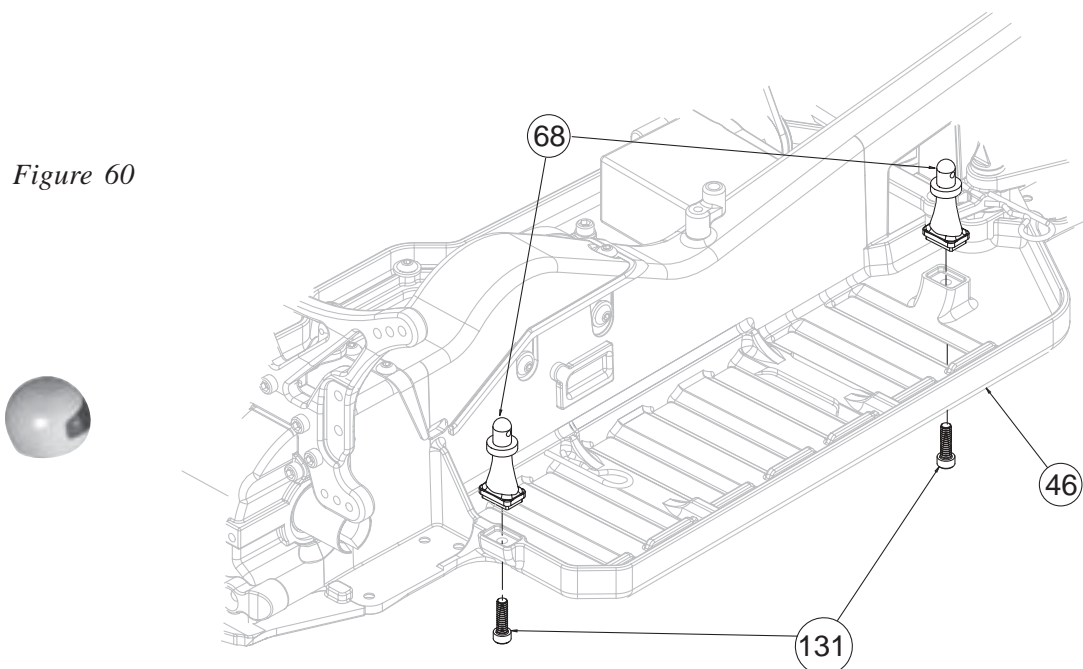

BAG F

Step F-1 Cartridge Assembly:

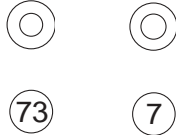

- ❑ 1. Place one shock O-ring (73) into the cartridge body (5), making sure that the O-ring sits flat in the bottom of the cartridge body.
- ❑ 2. Insert the cartridge spacer (7) into the cartridge body followed by a second O-ring.
- ❑ 3. Once the second O-ring is inserted, and is flush with the top of the cartridge body, press the cartridge cap (6) onto the cartridge body.
- ❑ 4. Make four cartridge assemblies.

Cartridges in some kits may be pre-assembled at the factory.

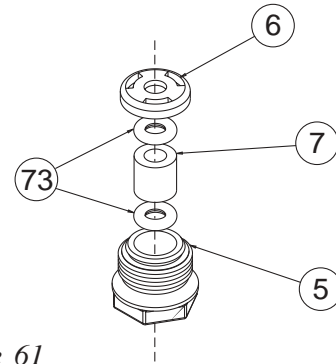
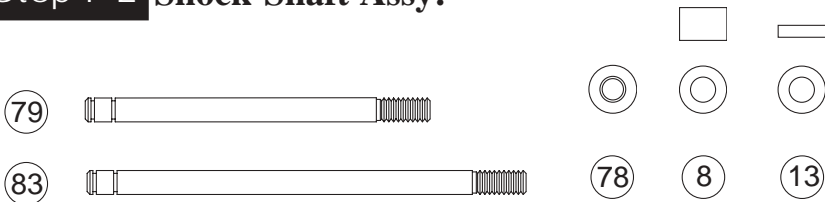

Figure 61

Step F-2 Shock Shaft Assy:



- ❑ 1. Place a "A" spacer (8) on each of the front shock shafts.
- ❑ 2. Place a drop of shock fluid (189) on the grooved end of each shock shaft (79, 83) and slide a cartridge, hex end first, down the shock shaft towards the threads on all four shafts as shown in Figure 62.
- ❑ 3. Using pliers or small vise grips, grasp the shock shaft between the grooves and thread a shock end (2) all the way onto the shaft until the threads stop. Do this for all shock shafts.
- ❑ 4. Place one "B" Spacer (8) and one 0.060 spacer (13) on each rear shock shaft above the shock cartridge cap (6).
- ❑ 5. Carefully snap a 1/4" shock mount ball (78) into each of the shock ends on each of the four shock shafts.

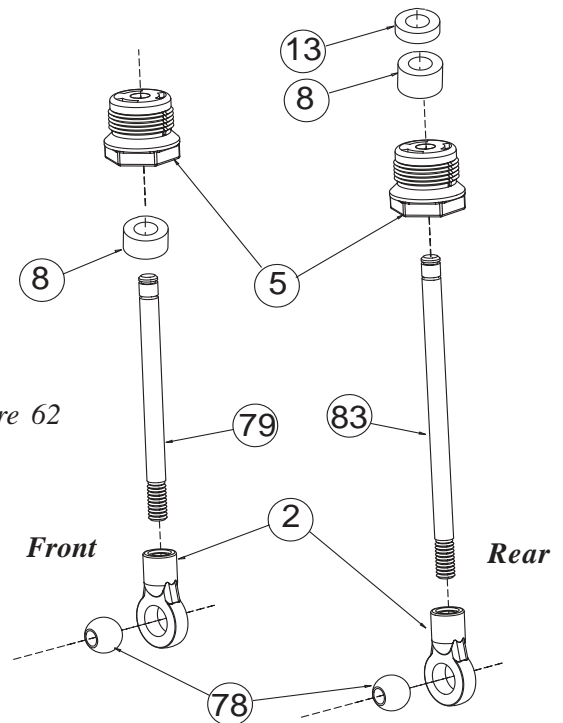

Figure 62

Step F-3 Shock Piston Install:



- ❑ 1. Snap a 1/8" E-clip (115) into the groove closest to the cartridge on both front and rear shock shafts (79,83).
- ❑ 2. Slide a "black", #57 shock piston (14) onto the front shock shafts (79) until the piston rests against the E-clip. Secure the pistons to the shafts with a second E-clip. These will be used on the front.
- ❑ 3. Slide an "red" #56 shock piston (9) onto each of the rear shock shafts (83) until the piston rests against the E-clip. Secure the pistons to the shafts with a second E-clip. These will be the rear shocks.

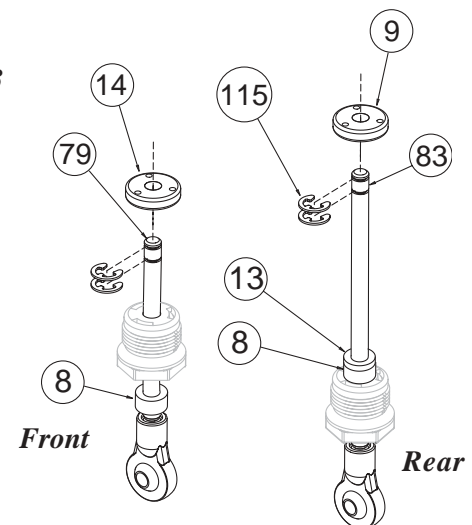



Figure 63

BAG F (Continued)

Step F-4 Shock Fluid

- ❑ 1. Match the short, front shock bodies (84) to the short front shafts (79), and the long, rear shock bodies (85) to the long rear shafts (83).
- ❑ 2. Fill the front shock body (84) with 30wt. shock fluid (189) up to the bottom of the threads inside the shock body.
- ❑ 3. Insert the front shaft assembly with the cartridge against the shock piston. Slowly tighten the cartridge about two full turns only. With the cartridge still slightly loose, slowly push the shock shaft assembly into the shock body. This will bleed the excess fluid out of the shock. Once the shaft assembly is all the way down, tighten the shock cartridge the rest of the way. Repeat this for the remaining front shock assembly and the two rear shock assemblies.

 *Be sure to keep the front and rear shock assemblies separated until they are assembled to the chassis.*

- ❑ 4. Now, with the shaft assembly still all the way in, secure the cartridge by tightening with pliers or a 7/16" wrench approximately 1/8 of a turn. There should be no air in the shocks as you move the shaft (79) in and out. If there is you need more fluid. If the shock does not compress all the way, the shock has too much fluid. Repeat for the remaining shock assemblies.

 *If leaking persists around the outside, tighten the cartridge.*

Figure 64



Step F-5 Shock Assembly:

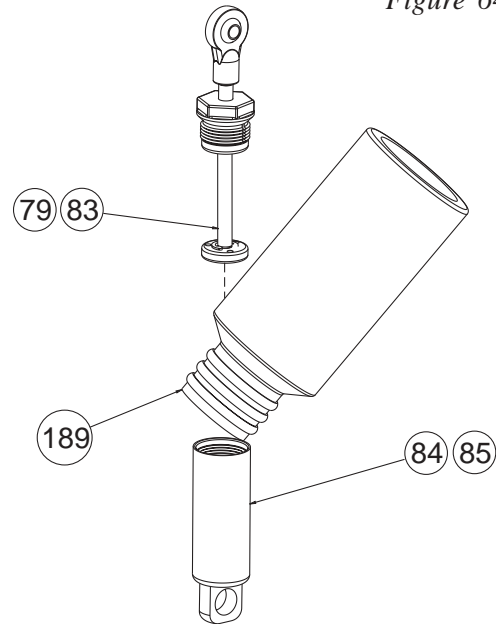
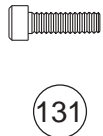

- ❑ 1. Snap a shock spring cup (3) onto each of the four shock shafts (79, 83) and push down onto the Shock End (2) until it stops.
- ❑ 2. Slide a 2" green spring (121) down over each of the two front shock assemblies so that it rests against the shock cup.
- ❑ 3. Slide a 2.5" pink spring (122) down over each of the two rear shock assemblies so that it rests against the shock cup.
- ❑ 4. Insert a 4-40 x 3/8" cap head screw (131) into the larger hole of each of the four shock collars (1) and thread it into the smaller hole.
- ❑ 5. With the collar loose, slide it down over the top of each shock body (84, 85) and against the shock spring. Tighten the collar to hold it in place.

 *Do not overtighten!*

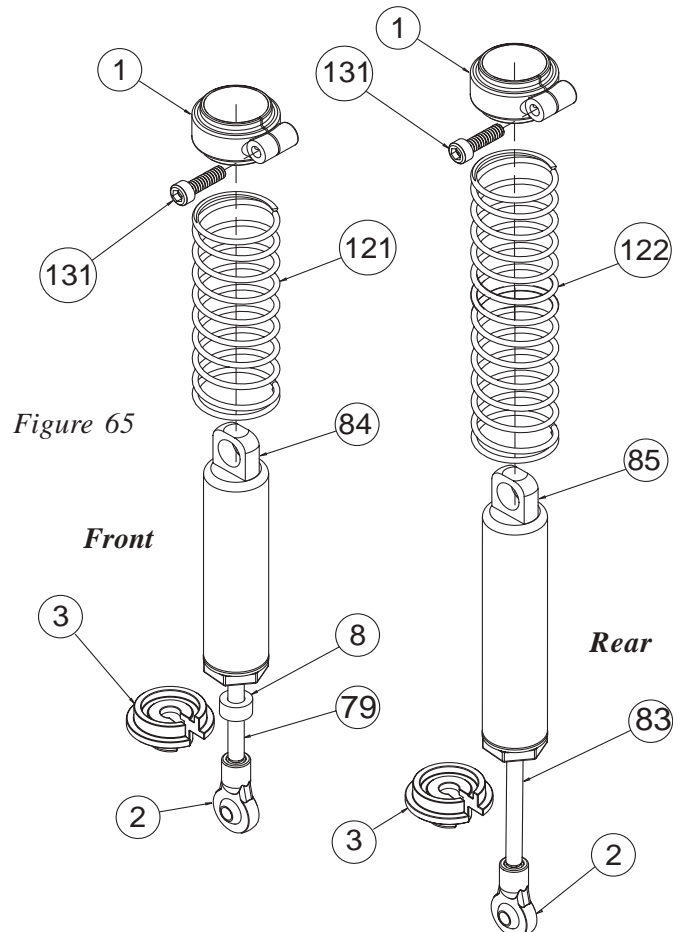

BAG F (Continued)

Step F-6 Rear Shock Install



184



129



25

❑ 1. Position the bottom of an assembled rear shock in front of the shock mounting area on the left rear suspension arm (12) as shown in Figure 66. Align the hole in the shock mount ball (78) with the inside hole in the arm.

❑ 2. Attach the shock to the rear arm by threading a 4-40 x 1/2" cap head screw (129) through the shock mount ball and all the way into the inside hole of the suspension arm.

❑ 3. Slide a "long" shock mount bushing (25), large side first, over the screw (133) on the left side of the tower.

 Before attaching the top of the shock, make sure that the dogbone is in place in the outdrive.

❑ 4. Place the top of the shock body (85) over the shock mount bushing. Secure the shock to the tower by threading a 4-40 locknut (184) onto the shock mount screw.

❑ 5. Repeat Steps 1-4 for the right rear shock assembly.

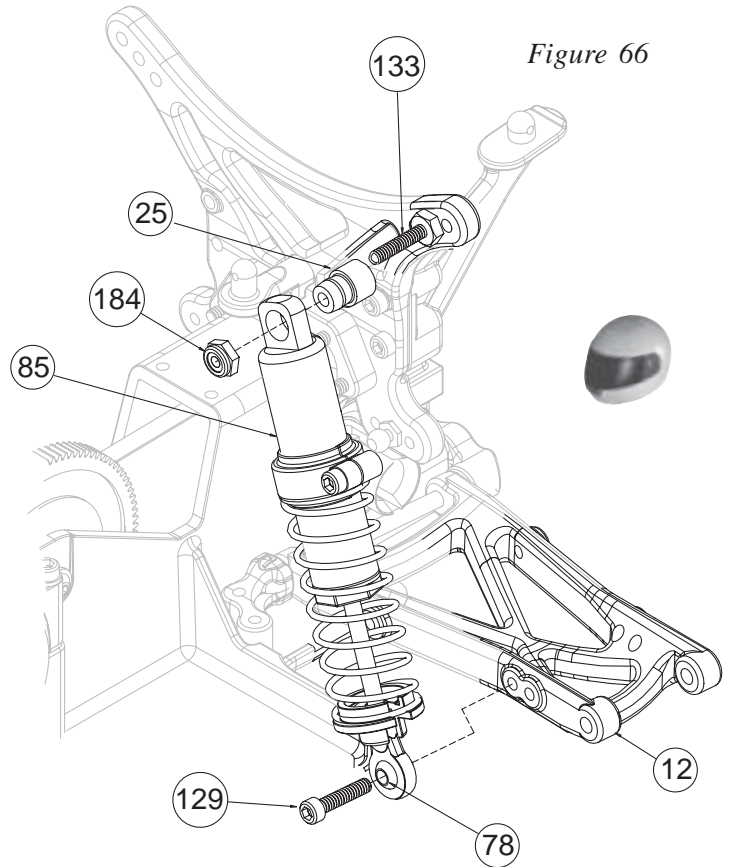

Figure 66

Step F-7 Front Shock Install



26



184



129

❑ 1. Position the bottom of an assembled front shock in front of the shock mounting area on the left front suspension arm (53) as shown in Figure 67. Align the hole in the shock mount ball (78) with the inside hole in the arm (53).

❑ 2. Secure the shock to the arm by threading a 4-40 x 1/2" cap head screw (129) all the way into the arm from the front.

❑ 3. Slide a "short" shock bushing (26), large side first, over the screw (130) on the left side of the front shock tower.

 Once again, before attaching the top of the shock, make sure that the dogbone is in place in the outdrive.

❑ 4. Place the top of the front shock body (84) over the shock mount bushing on the tower. Secure the shock assembly to the tower by threading a 4-40 locknut (184) onto the shock mount screw.

❑ 5. Repeat Steps 1-4 for the right shock assembly.

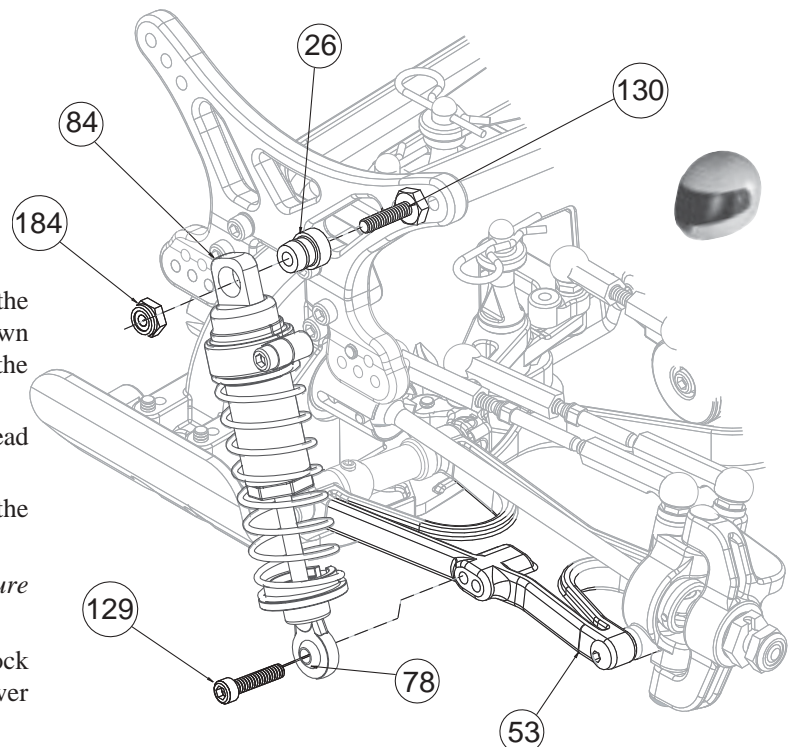



Figure 67

BAG G

Step G-1 Tire Mounting and Installation



- ❑ 1. Inspect the inside of the front (76) and rear (75) tires for any excess material. If present, trim the excess rubber to ensure proper seating of the tire on the front (22) and rear (21) wheel.

 Do not set the tires on furniture as they may leave permanent stains!

- ❑ 2. Locate the two narrow (188) front, and two wide (187) rear foam tire inserts.



IMPORTANT NOTE: *The tires included with the XXX-4 are not directional, but you should install each of the tires to the wheels in one direction. When installed correctly, the writing on all four tires will face towards the outside of the rim when mounted onto the car. This will place the rib in the tread pattern towards the outside as well.*

- ❑ 3. Install the foam tire inserts into the tires. Pull the tire over the wheel and squeeze the tire to properly seat it into the grooves of the wheel. Make certain that the tire insert is not pinched between the tire and the wheel.



IMPORTANT NOTE: *Always wear eye protection, a mask, and always read and follow the manufacturer's safety warnings regarding the use of any adhesives.*

- ❑ 4. The tires should now be glued to the wheels. This can be done by using a fast-curing superglue or cyanoacrylate glue available at your local hobby shop. Allow the glue to dry thoroughly before continuing. Team Losi Tread Lock Tire Glue (A-7880 "Thick", A-7881 "Thin") is the best glue available for gluing R/C car tires. This glue was produced specifically for this purpose.
- ❑ 5. Attach a wheel to the left rear axle by lining up the pin in the axle with the pin slot in the wheel.
- ❑ 6. Secure the rear wheel by threading an 8-32 locknut (113G), (*supplied with your CVD kit*), onto the rear axle and tighten.
- ❑ 7. Repeat Steps 5-6 for the remaining tire assemblies also using an 8-32 locknut (114J) (*supplied with your front CVD kit*) to secure the front wheels.

Figure 68

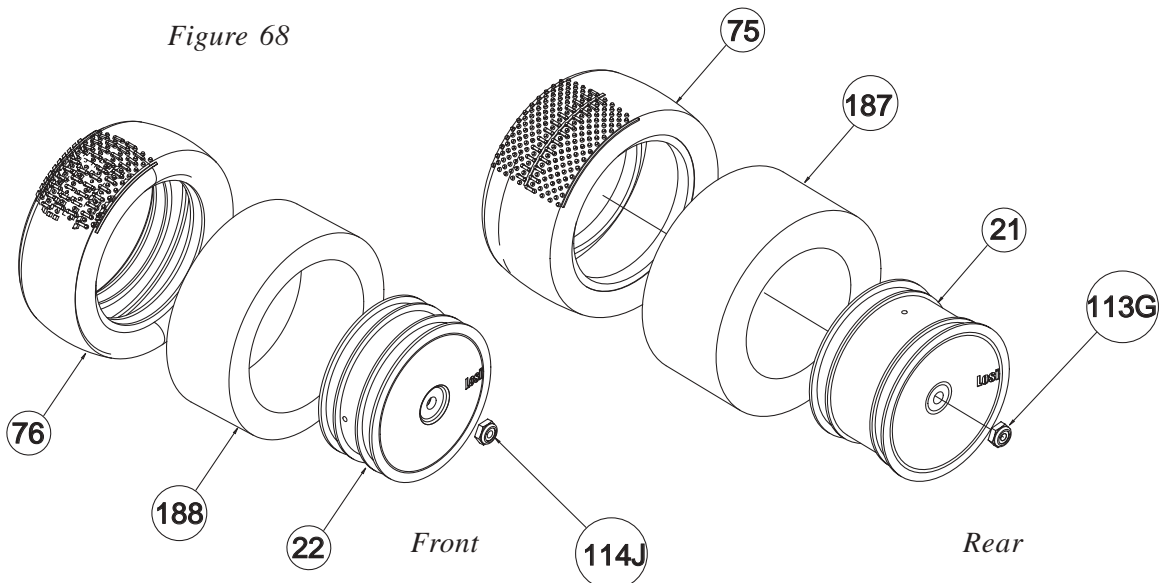

BAG H

Step H-1 Front Bumper Install

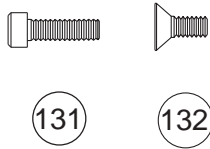
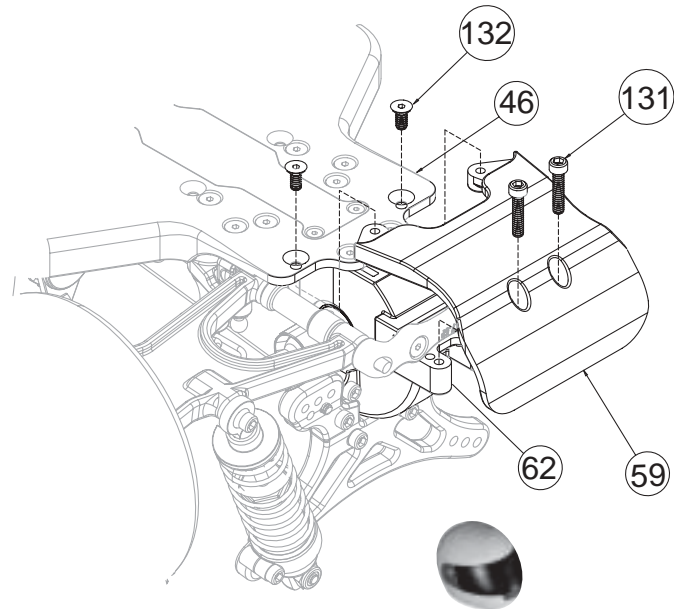

Figure 69

1. Holding the car upside-down install the front bumper (59) by lining up the holes in the fork of the front bumper with the holes in the chassis (46). It should rest on the front diff cover (62). Secure the front bumper by threading two 4-40 x 1/4" flat head screws (132) through the chassis into the two holes in the back of the front bumper as indicated in Figure 69.
2. Thread two 4-40 x 3/8" cap head screws (131) through the front bumper into the front diff cover.



Step H-2 Rear Bumper Install



Figure 70

1. Install the rear bumper (60) by lining up the forks of the rear bumper with the back of the chassis (46). Thread two 4-40 x 3/8" flat head screws (134) through the rear bumper into the holes in the rear diff cover (69) as indicated in Figure 70 and tighten.

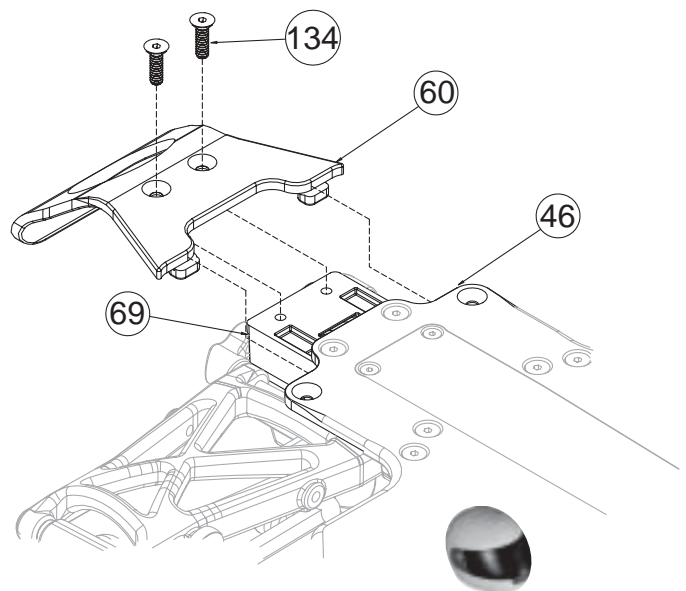

BAG H (Continued)

Step H-3 Motor Plate Install



147

❑ 1. Place the motor mount (93) against the motor (*not included*) so that the shaft on the motor is centered in the large hole in the motor plate and the flat surface of the motor plate rests against the motor. Align the holes in the motor mount with the holes in the motor as indicated in Figure 71.

❑ 2. Secure the motor mount to the motor by threading the two 3mm x 6mm Button Head screws (147) through the two holes in the motor plate, and tightening.

 *If there are two sets of holes in the motor, thread the screws into the set of holes that will allow the power tabs to face the speed control (ESC) with the motor in its lowest position in the chassis. This is the optimal location for your vehicle.*

❑ 3. Attach the pinion gear (*not included*) to the motor shaft with the tooth section of the gear away from the motor as shown.

Figure 71

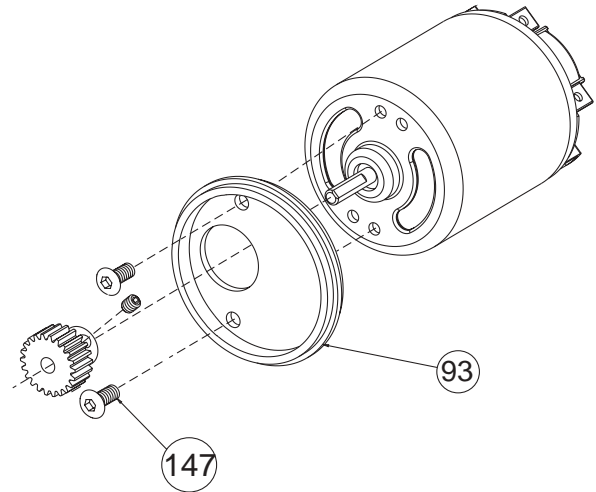

Step H-4 Motor Install



150



94



144

❑ 1. Press two threaded inserts (94) into the bottom of the chassis (46) in the holes with the hex. Be sure that you line up the hex on the insert with the hex in the bottom of the chassis. The inserts should be installed in the direction shown in Figure 72.

❑ 2. Install the motor mount, with the motor attached, in the groove on the left side of the chassis. Check alignment of the pinion gear with the spur gear (71). If the two gears don't align properly, remove the motor and adjust the position of the pinion gear. Check again for proper alignment.

❑ 3. Once the pinion gear is properly aligned with the spur gear, place the motor clamp (41) over the motor plate as shown. Slide a ball stud washer (150) over each of the 4-40 x 1.5" cap head screws (144). Thread a 4-40 x 1.5" cap head screw through the two holes in the motor clamp into the threaded inserts in the chassis, but **don't tighten** the screws yet. Check the gear mesh through the opening in the right side of the chassis. To adjust the gear mesh, rotate the motor - counter-clockwise to loosen the gear mesh; and clockwise to tighten the gear mesh. Once the gear mesh has been adjusted, tighten the motor clamp screws.

 *The gears need a small amount of backlash in order to function properly.*

❑ 4. Insert the rectangular, gear mesh access plug (74), bevelled side first, in the opening on the right side of the chassis.

Figure 72

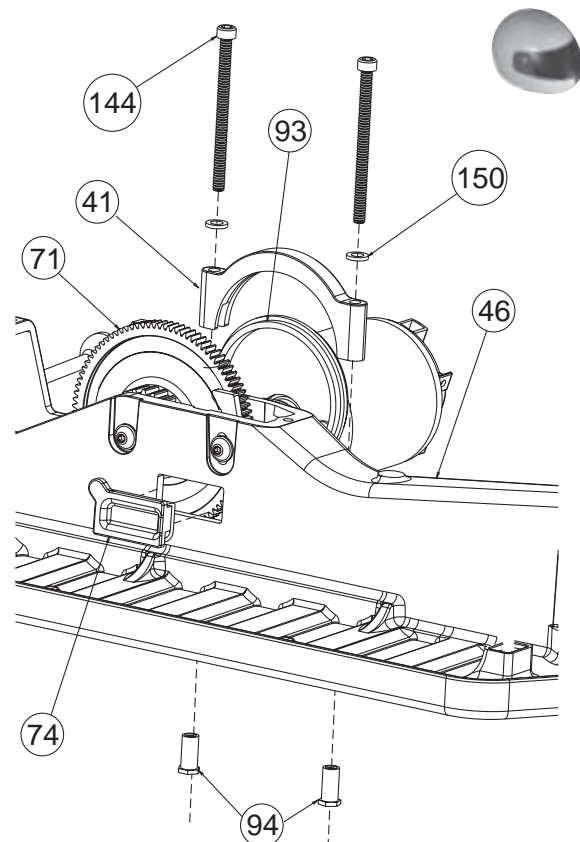

BAG H (Continued)

Step H-5

Battery Strap Install

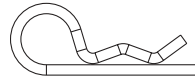

The battery strap can be mounted in one of two ways to accommodate different styles of batteries. If you will be running matched-type cells, or individual cells laid out side-by-side, the TL logo should be facing away from the top of the chassis as shown in Figure 73 "B". If, however, you are using a pre-assembled stick pack, the TL logo should be facing down towards the top of the chassis as shown in Figure 73 "A".

1. Once the battery pack (not included) is installed, the plastic battery strap (28) will hold the batteries in place. The battery strap (28) slides over the two posts (68) on the right side of the chassis (46). The strap is secured to the post with a body clip (124) at each end.

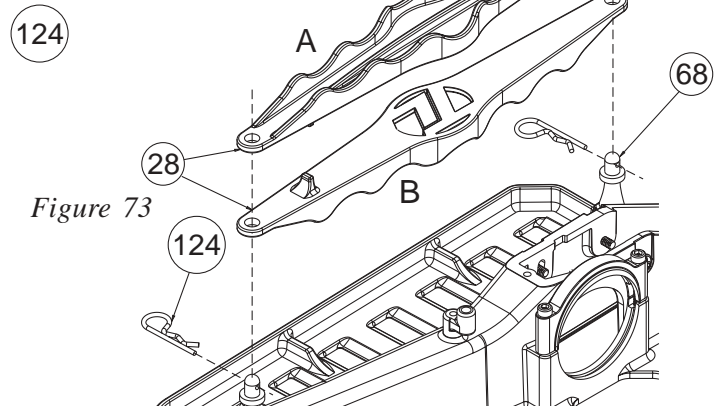

Step H-6

Receiver/Antenna Install



1. Cut a piece of two-sided tape (148) to the same size as the bottom of the receiver (*not included*). Peel one side of the backing off and stick the tape to the bottom of the receiver.

2. Make sure that the area on the chassis (46), between the motor and the servo, is clean. Wipe this area off with a clean cloth or rag.

Tip: Rubbing alcohol can be used to clean any oily residue that may be present on the chassis or receiver. Allow the alcohol to dry before applying the two-sided tape.

3. Peel the backing off the the two-sided tape and install the receiver to the left side of the chassis, between the motor and servo, with the antenna wire exiting the receiver towards the center of the car as shown in Figure 74.

4. Run the antenna up the center rib, in the chassis, through the antenna mount (66) into the small hole. Press the antenna mount into the hole in the top of the center rib in the chassis. Slide the antenna wire through the antenna tube (120) so that the wire comes out the other end of the tube.

5. While pulling the wire through the antenna tube, slide the antenna tube down and push it firmly into the antenna mount on the main chassis.

6. Fold the wire down over the antenna tube and place the antenna cap (72) over the tube and excess wire as shown in Figure 74.

7. Run the receiver wire from your speed controller in the channel along the side of the chassis. Hold the wire in place by first placing a #4 washer (151) over two 4-40 x 1/4 button head screws (138) and threading them into the chassis. **Be careful not to pinch the wire or overtighten the screws.**

Tip: If antenna wire is shorter than the tube, remove the tube and cut off enough of the tube so that the wire will extend about 3/4" past the end of the tube. **DO NOT** cut off any excess antenna wire. Doing so may cause you car to "glitch".

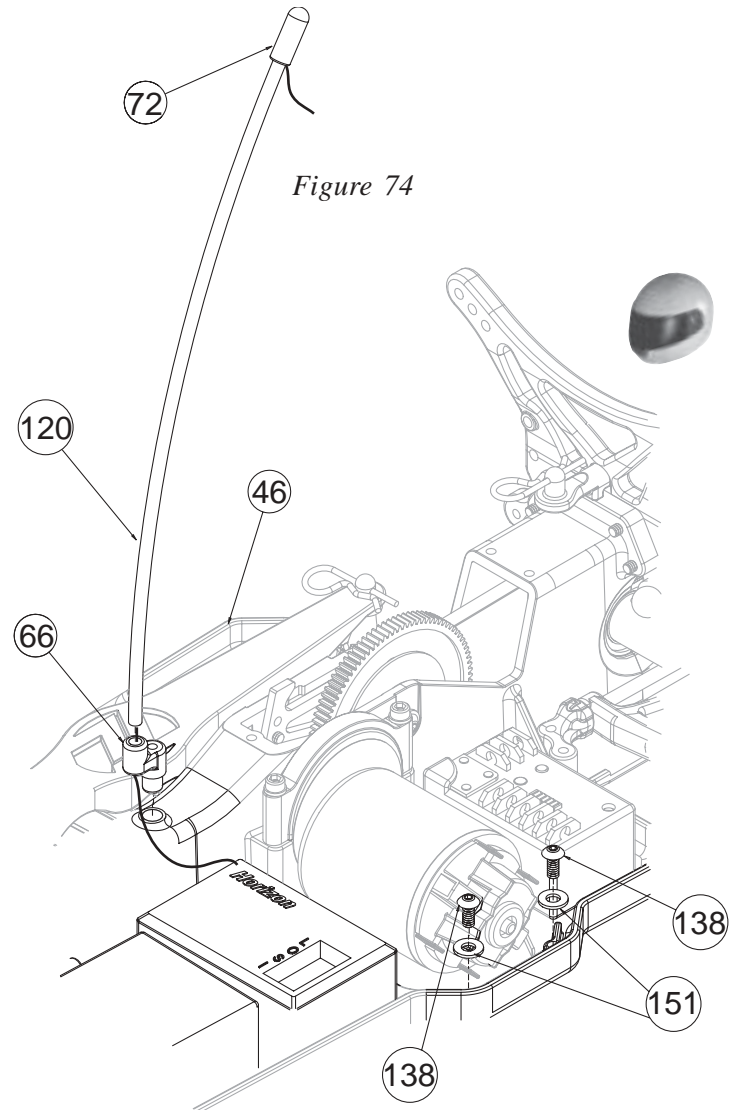

BAG H (Continued)

Step H-7 Gear Cover Installation



138

1. Locate the gear cover (191) and cut the bottom side of it along the trim line as shown in gray in Figure 75B. Drill three 1/8" mounting holes in the gear cover at the three locations marked with dimples.
2. Place the trimmed gear cover over the spur gear (71) and secure it with three 4-40 x 1/4" button head screws (138) through the three open holes in the top of the chassis (46).

 You may opt. to run the ESC wires through the gear cover with the small cut-out on the bottom of the gear cover shown in Figure 75A. If you will be running the wires over the gear cover you should leave that material there.

 It is recommended that you **do not** run the ESC wires through the gear cover when running your XXX-4 in extremely dusty conditions.



Figure 75B

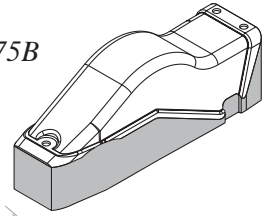
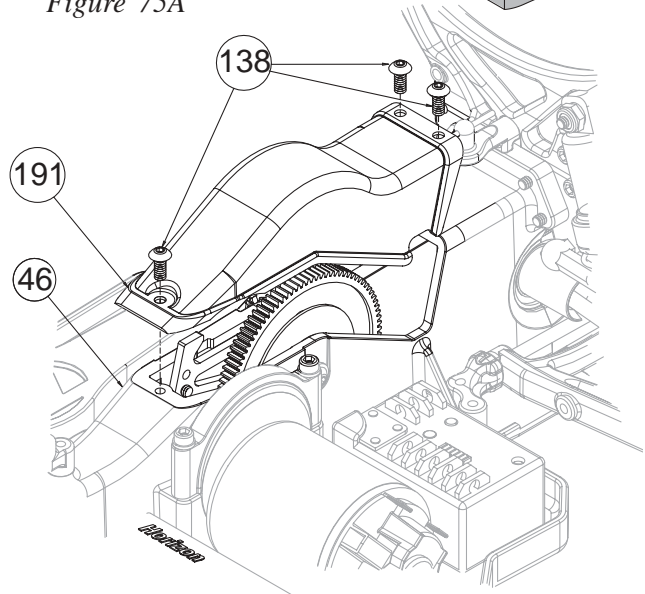
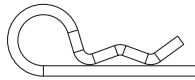

Figure 75A



Step H-8 Body Mounting



124

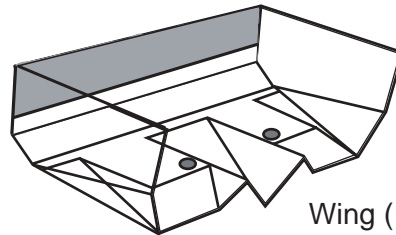

Wing (192)

1. Trim the body (192) and wing along the trim lines as shown.
2. Once the perimeter of the body is cut, locate the three dimples in the body used for mounting (two in the front, and one in the rear) and locate the dimple for the antenna tube. Drill each of them to 3/16" diameter holes.
3. Now locate the three recessed circular section on each side in the front of the body. Remove the inner circular section creating holes for ventilation.
3. Align the holes in the body with the body mounts and attach the body to the rolling chassis using three body clips (124).

Figure 76

Body (192)

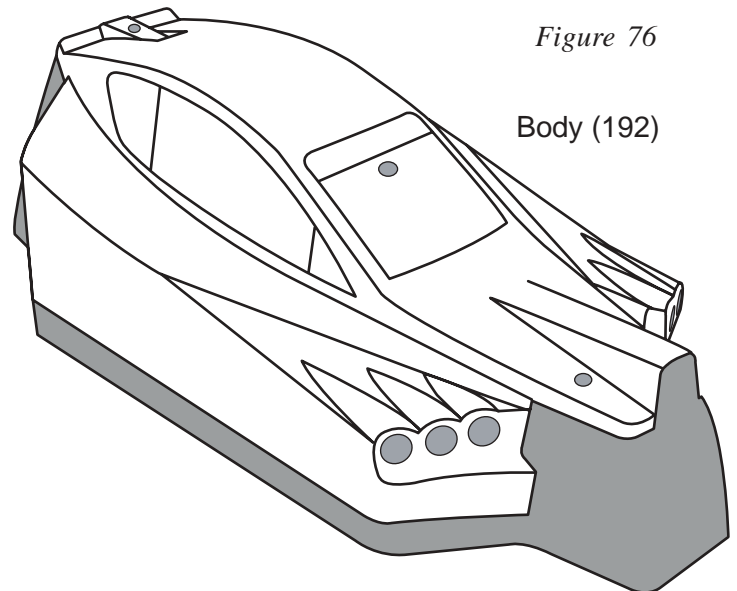

BAG H (Continued)

Step H-9

Wing Installation

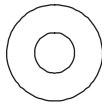

67

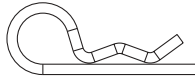

124

- ❑ 1. Make two 3/16" diameter holes in the wing (192) where the dimples are located.
- ❑ 2. Align the holes in the rear wing with the wing mounts on the rear shock tower.
- ❑ 3. Secure the wing to the wing mounts by first placing a wing washer (67) over the mount on top of the wing and then inserting a body clip (124) in each hole.

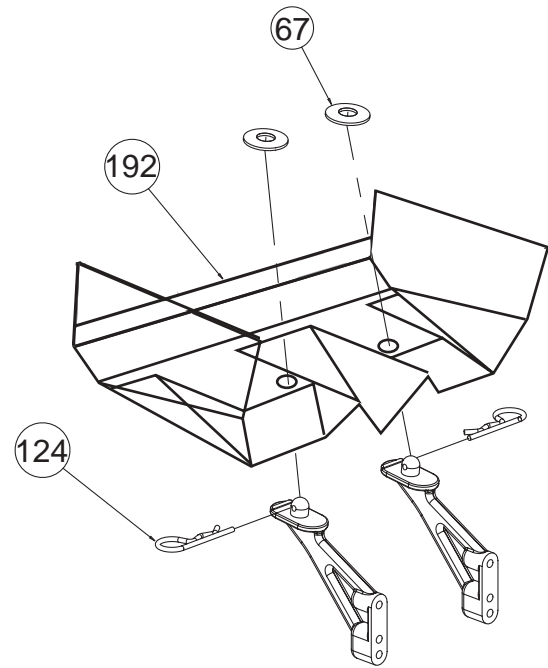

Figure 77

FINAL CHECKLIST

BEFORE RUNNING YOUR NEW XXX-4 Buggy for the first time, you should run down the following checklist — in order — and complete the listed tasks. I'm sure you're anxious to get out and run your new XXX-4 now that it's built, but following this simple checklist will help to make your first run with your new car much more enjoyable.

1. Adjust the differential

While holding the chassis with only the left side tires firmly on the ground give the car about a quarter throttle for ten seconds. The right side tires should spin freely during this time. Repeat this with the right side tires held firmly to the ground allowing the left tires to spin. Feel the diff action and tighten slightly if necessary.

2. Check for free suspension movement

All suspension arms should move freely. Any binds will cause the car to handle poorly. The steering should also operate very freely.

3. Set the ride height

Adjust the chassis ride height so that the rear arms are sitting at level. Make the front a little lower than the rear.

4. Set the camber

Both front tires should have 2 degrees of negative camber, and both rear tires should have 1 degree of negative camber (Top of the tire leans in). It is critical that both front tires and both rear tires be adjusted the same.

5. Set the front toe-in

Adjust the front tie rods so that, when the steering is straight on the transmitter, the front tires are both pointing straight. It is recommended that you start with the front toe-in set to zero (no toe-in or toe-out).

6. Charge a battery pack

Charge a battery pack as per battery manufacturer's and/or charger manufacturer's instructions so that radio adjustments can be made. Never plug the battery backwards into the speed control.

7. Adjust the speed control

Following the manufacturer's instructions, adjust your speed control, and set the throttle trim on your ESC so the the car does not creep forward when not applying throttle. Make sure that there is not too much brake being applied when the trigger/stick is in the neutral position. Some speed controls have a high/low setting for the throttle.

8. Set transmitter steering trim

The steering trim tab on the transmitter should be adjusted so that the car rolls straight when you are not touching the steering wheel/stick. If the servo was installed correctly, as per Tables 31A and 31B, the wheels should turn equally to the left and right. If this is not the case, refer to Table 31B and ensure that the steering servo and rod (Figure 34 and 35) were properly installed. Make sure the throttle trim is set so that the motor does not run when in the neutral position. You may wish to run one "click" of brake to be safe.

TIPS AND HINTS FROM THE TEAM

Before you start making changes on your XXX-4 Buggy you need to make a few decisions. Tires and how they are set-up have a tremendous impact on overall performance. Before you start making changes on the chassis take a moment to observe a few of the fastest cars and what type of tire and inner liner they are running. Also note the wheel diameter and width as this can also effect how the tires perform. When making chassis changes you should first decide where you feel the car needs to be different. This is commonly referred to as changing the "balance". Since the XXX-4 is a four-wheel drive chassis you have two ends of the car working separately yet together. First decide if the front of the car needs to be adjusted or the back. You will want to work with the rear if the car enters the turn with the front end sticking and tracking well while the rear end either does not want to follow or simply doesn't know what it wants to do. The opposite is true if the rear end seems to want to push the front end through the corners or the front dives into the corner uncontrollably. You will notice that several different adjustments have similar effects on the handling as well. You will find the best adjustment will become a personal decision based on the "feel" that each of these adjustments yield. This also reflects on the "balance" we referred to earlier. Never make more than one change at a time. If the change you made works adversely or doesn't address your need return to the stock position and try something else. Team Losi's development team has put hundreds of hours on the XXX-4 to arrive at the set-up we put in the instruction manual. If you find that you have lost the "handle" go back to the kit (stock) set-up as this has proven to be reliable, consistent, and easy to drive.

Front End:

Shock Location: Leaning the shocks in (mounting them closer to the center of the tower) will give a smoother transition as you enter into turns and improve consistency but will yield less total steering and give a slower reaction. This might be helpful on high bite surfaces. Standing the shocks up (mounting them further out from the center of the tower) will increase responsiveness and generate more total steering. Forward traction is also increased, as is on-power steering. When moving the shocks to a more upright position you may find that you will have to change to a softer spring to smooth out the reaction. This might work well on shorter more technical tracks.

Toe-in/Out: is the parallel relationship of front tires to one another. Toe-in/out adjustments are made by changing the total length of the steering rods. If the front tires appear to be pointing inward to a spot in front of the car (toe-in) you can expect the car to react a little slower but have a little more steering from the middle of the turn out. The opposite is true if the front tires appear to be pointing to points in front and to either side of the car (toe-out). This (toe-out) will make the car turn into the corner better but will allow less steering from the middle of the corner out.

Camber Link: Making the camber link shorter (moving it further away from the center of the tower) tends to give more off-power steering into the turn but can also make the steering feel a bit erratic. Making the camber link longer (moving it closer to the center of the tower) will slow down the reaction of the steering but will make the chassis more forgiving.

Camber; refers to the angle of the wheels/tires in relation to the track surface when viewed from the front or back. Negative camber means that the top of the tire leans inward toward the chassis. Positive camber means the top of the tire leans out away from the chassis. You should never need to run positive camber and will always want to run at least a little negative camber. You can use any square object to check this by placing it so one edge is flat on the surface and the other is up against the outer surface of the wheel. There should always be at least a slight gap at the top of the wheel (negative camber). There should never be a gap at the bottom of the wheel (positive camber). Adding 1 degree front camber will typically increase steering.

Front Kickup/Anti-dive; is the angle of the front arms in relation to the track surface. The kickup is controlled by the pivot blocks that mount the inner hinge pins of the front suspension arms to the chassis. You have three options with the included mounts, 5, 7.5, and 10 degrees. The front is marked with a "5" and a "10" at the middle of the surface facing forward. If this block is mounted with the "5" readable, there is 5 degrees of kickup, if the "10" is readable, then there is 10 degrees of kickup. The other included pivot block is labeled "7.5" and gives 7.5 degrees of kickup. The "10" setting is best for bumpy surfaces and makes the car very forgiving. As you reduce the amount of kickup the steering will get more aggressive entering the turn. Reducing this will also improve front braking traction entering turns but will reduce the chassis' ability to handle bumpy surfaces.

Caster; is the angle of the kingpin from vertical when viewed from the side. You will always run 10 degrees of positive caster where the top of the kingpin leans back toward the rear of the car. Total caster is determined by adding the amount of kickup and the amount of kingpin inclination of the front spindle carriers. The stock spindle carriers in the kit are 10 degree, which mean the total caster is determined by the kickup. Reducing total caster will give less off power steering while giving more on power steering on exit. More caster will give greater steering into the turn but less steering as you exit.

Front Diff: Running the diff a little tighter will give less off power turn-in but increase on power steering as you exit a turn. Running it a little looser will give more initial turn-in but make the car want to "push" (lose steering) on exit.

Ride Height; is the height of the chassis in relation to the track surface. Initially, set the front just below the rear ride height (arms at level). This will work well on most bumpy surfaces. This will also generate more weight transfer and chassis roll, which can help on slick surfaces. Lowering the ride height will make the car change direction quicker and should be helpful on high traction surfaces.

Chassis/Drivetrain

Battery Position: Moving the battery pack forward will give more steering and less rear traction. Moving the pack to the rear will increase rear traction and diminish steering slightly. Splitting the pack leaving an empty space in the middle will have various effects depending on the traction and size of the track.

Belt Tension; can be run a little looser on long tracks and with stock motors. It is normal for the belt to skip (2 or 3 clicks) under heavy braking without doing harm to the belt. Do not run the belt too loose or it will drag on the chassis and bottom cover hurting performance.



Slipper Adjustment **IMPORTANT NOTE!** *The slipper adjustment on the XXX-4 is crucial to the life of the drivetrain. If the slipper adjustment is set too loose, the car will not have proper acceleration and will create excessive heat in the drivetrain components which could lead to failure. If the slipper adjustment is set too tight the drivetrain will experience excessive loads that can also lead to drivetrain failure. When properly adjusted, the slipper should slip for about 2 feet on a carpet or high traction surface.*

Loosening the Slipper; insert the slipper wrench on the slipper flange and position the car with the **REAR** end closest to you. Hold the slipper wrench with your right hand while holding the right rear tire down with your right arm. Pick up the left rear tire and rotate towards you slowly.

Tightening the Slipper; insert the slipper wrench on the slipper flange and position the car with the **FRONT** end closest to you. Hold the slipper wrench with your right hand and hold down the left front tire (your right side) with your right arm. Pick up the right front tire and rotate towards you slowly.

Back End:

Shock Location: Leaning the shocks in (toward the center of the tower) frees up the back end of the car, allowing easier rotation in the turn. This might be helpful for fast flowing tracks where corner speed is critical. Moving the shocks out (away from the center of the tower) will give more forward traction but slows the initial reaction into the turn with a more abrupt rear rotation. This can be good for tight tracks.

Camber Link: Moving the rear camber link to the outside position (shorter) on the tower and/or the inside position of the hub, will give more traction and chassis roll but less steering and stability. This should also carry more corner speed and help on slick surfaces. Moving the camber link to the inside position (longer) will increase stability but slow down rear rotation. Moving the link to the outside position on the hub will give similar results to moving the link farther inside on the tower.

Rear Toe-in: There is 2 degrees of toe-in per side stock. Adding toe-in will create more forward traction and make the car freer on entering a turn. This is good for slick surfaces. Too much toe-in will make the car twitchy and hard to drive.

Camber; refers to the angle of the wheels/tires in relation to the track surface when viewed from the front or back. Negative camber means that the top of the tire leans inward toward the chassis. Positive camber means the top of the tire leans out away from the chassis.

Anti-Squat; is like the "kick-up" at the front except it works slightly different. Marked and used like the front, you can choose from 1, and 3 degrees of anti-squat (pin angle) and 1 degree of pro-squat. 1 degree pro-squat is the starting point. Adding (from +1, 1, 3, degrees) will reduce rear grip and allow easier rotation into a turn and increase the traction out of the turn. This is good for slicker track surfaces.

Rear Hub Spacing: Spacing the hubs forward (spacers behind the hub) will give more forward grip and initiate the entrance into turns off power and less off-power steering. Moving the arms back (spacers at the front of the hub) will give less forward grip and slow down initial reaction into turns and more on-power steering.

Overdrive/ Underdrive: In bag H you received a 41T pulley for you XXX-4. This allows you to over-drive (make the front tires turn faster) or underdrive (make the front tires turn slower) the car. Using the 41T pulley in the front of your car will give you overdrive. This will give the car less offpower steering and will give you more steering exiting the turn. Running the 41T pulley in the rear will underdrive the car. This will give you more steering entering the turn and less exiting the turn. If you do mix up your pulleys, you can distinguish the 41T from the 42T by looking for a ridge in the side of the flange on your 42T pulley. The 41T pulley does not have any type of marking on the flange area (the 41T pulley is also marked with a black line on the flange).

We are sure that you will find the **XXX-4 Buggy** to be the most versatile and easiest car to drive fast with great consistency. We at Team Losi hope this information helps you to enjoy your **XXX-4 Buggy** and racing as much as we do. For the latest in setup and accessory parts information, visit the Team Losi website at: www.TeamLosi.com and go to the "Meet the Team" tab on the left side of the page. All your questions will be answered in the order received to the best of our knowledge by our own Team Losi R&D race team.

SPARE PARTS LIST

<u>KEY #</u>	<u>KIT/PART DESCRIPTION</u>	<u>PART NO.</u>	<u>SPARE PARTS DESCRIPTION</u>
1	SHOCK COLLAR	A-5023	Spring Clamps & Cups
2	SHOCK END	A-5023	Spring Clamps & Cups
3	SHOCK CUP	A-5023	Spring Clamps & Cups
4	ROD-ENDS ADJUSTABLE/30	A-6005	H.D. 30 Degree Plastic Rod Ends
5	SHOCK CARTRIDGE BODY/SNAP	A-5015	Double O-Ring Shock Cartridge
6	SHOCK CARTRIDGE CAP/SNAP	A-5015	Double O-Ring Shock Cartridge
7	SHOCK CARTRIDGE SPACER	A-5015	Double O-Ring Shock Cartridge
8	A AND B SHOCK SPACER	A-5015	Double O-Ring Shock Cartridge
9	SHOCK PISTON RED #56	A-5046	Teflon Shock Piston #56,Red
10	SHORT, 30 DEGREES ROD-END	A-6010	Short, 30 Degree, Plastic Rod End
11	RIGHT REAR ARM	A-2131	Rear Suspension Arms XXCR, XX-4, XXX, XXX-4
12	LEFT REAR ARM	A-2131	Rear Suspension Arms XXCR, XX-4, XXX, XXX-4
13	REAR HUB SPACER	A-2127	CR Rear Hub Spacer
14	SHOCK PISTON #57	A-5045	Teflon Shock Piston #57,(Black)
15	RIGHT SPINDLE ARM	A-1216	Front Spindles & Carriers XX4/XXX-4
16	LEFT SPINDLE ARM	A-1216	Front Spindles & Carriers XX4/XXX-4
17	SPINDLE CARRIER, RIGHT	A-1216	Front Spindles & Carriers XX4/XXX-4
18	SPINDLE CARRIER, LEFT	A-1216	Front Spindles & Carriers XX4/XXX-4
19	MOLDED OUTDRIVE, MALE	A-3097	Molded Out-Drive Set
20	MOLDED OUTDRIVE, FEMALE-	A-3097	Molded Out-Drive Set
21	REAR WHEEL	A-7104	Solid Face Rear Wheels, Yellow
22	FRONT WHEEL	A-7047	Solid Face Front Wheels, Yellow
23	HUB LEFT	A-2228	Rear Hub Carrier 0deg (XXX/T/4)
24	HUB RIGHT	A-2228	Rear Hub Carrier 0deg (XXX/T/4)
25	LONG SHOCK BUSHING	A-5013	Upper Shock Mount Bushings
26	SHORT SHOCK BUSHING	A-5013	Upper Shock Mount Bushings
27	DIFF NUT CARRIER	A-2909	"Monster Diff" Adjustment Screw & Hardware
28	BATTERY STRAP	A-4240	Battery Strap & Droop Gauge
29	STEERING TUNNEL	A-4210	Chassis Bottom Cover Set XXX-4
30	LEFT BELLCRANK	A-1540	Steering Bellcranks, Servo Saver & Mounts XXX-S/4
31	RIGHT BELLCRANK	A-1540	Steering Bellcranks, Servo Saver & Mounts XXX-S/4
32	DRAG LINK	A-1540	Steering Bellcranks, Servo Saver & Mounts XXX-S/4
33	STEERING BUSHINGS	A-1540	Steering Bellcranks, Servo Saver & Mounts XXX-S/4
34	SERVO MOUNT-A	A-1540	Steering Bellcranks, Servo Saver & Mounts XXX-S/4
35	SERVO MOUNT-B	A-1540	Steering Bellcranks, Servo Saver & Mounts XXX-S/4
36	SERVO SAVER BASE 23T	A-1540	Steering Bellcranks, Servo Saver & Mounts XXX-S/4
37	SERVO SAVER BASE 24T	A-1540	Steering Bellcranks, Servo Saver & Mounts XXX-S/4
38	SERVO SAVER BASE 25T	A-1540	Steering Bellcranks, Servo Saver & Mounts XXX-S/4
39	SERVO SAVER OUTER	A-1540	Steering Bellcranks, Servo Saver & Mounts XXX-S/4
40	SERVO SAVER WASHER	A-1540	Steering Bellcranks, Servo Saver & Mounts XXX-S/4
41	MOTOR MOUNT STRAP	A-4216	Motor Mount Clamp XXX-S/4
42	42T DIFF PULLEY	A-3211	Pulley Set Front and Rear Idler XXX-S/4
43	41T DIFF PULLEY	A-3211	Pulley Set Front and Rear Idler XXX-S/4
44	IDLER PULLEY	A-3211	Pulley Set Front and Rear Idler XXX-S/4
45	42T DIFF PULLEY FLANGE	A-3211	Pulley Set Front and Rear Idler XXX-S/4
46	CHASSIS	A-4202	Main Chassis XXX-4
47	LEFT FRONT INNER PIVOT	A-1232	Front Pivot Support Set XXX-4
48	RIGHT FRONT INNER PIVOT	A-1232	Front Pivot Support Set XXX-4
49	PIVOT BALL	A-6053	Molded Suspension Pivot Balls
50	FRONT MAIN PIVOT 7.5 DEG	A-1232	Front Pivot Support Set XXX-4
51	FRONT MAIN PIVOT 5-10 DEG	A-1232	Front Pivot Support Set XXX-4
52	FRONT SHOCK TOWER	A-1205	Front Shock Tower XXX-4
53	FRONT ARM L/R	A-1211	Front Suspension Arms XXX-4
54	LEFT REAR INNER PIVOT	A-2232	Rear Pivot Support Set XXX-4
55	RIGHT REAR INNER PIVOT	A-2232	Rear Pivot Support Set XXX-4
56	REAR MAIN PIVOT 1 DEG	A-2232	Rear Pivot Support Set XXX-4
57	REAR MAIN PIVOT 1-3 DEG	A-2232	Rear Pivot Support Set XXX-4

SPARE PARTS LIST

<u>KEY #</u>	<u>KIT/PART DESCRIPTION</u>	<u>PART NO.</u>	<u>SPARE PARTS DESCRIPTION</u>
58	REAR SHOCK TOWER	A-2205	Rear Shock Tower XXX-4
59	FRONT BUMPER	A-4219	Front & Rear Bumper Set XXX-4
60	REAR BUMPER	A-4219	Front & Rear Bumper Set XXX-4
61	BOTTOM CHASSIS COVER	A-4210	Bottom Chassis cover XXX-4
62	FRONT DIFF COVER	A-4214	Front & Rear Diff Cover Set
63	WING MOUNT	A-4221	Body, Wing, Antenna Mounts & Battery Posts
64	FRONT BODY MOUNT	A-4221	Body, Wing, Antenna Mounts & Battery Posts
65	REAR BODY MOUNT	A-4221	Body, Wing, Antenna Mounts & Battery Posts
66	ANTENNA MOUNT	A-4221	Body, Wing, Antenna Mounts & Battery Posts
67	WING MOUNT WASHER	A-4221	Body, Wing, Antenna Mounts & Battery Posts
68	BATTERY POST	A-4221	Body, Wing, Antenna Mounts & Battery Posts
69	REAR DIFF COVER	A-4214	Front & Rear Diff Cover Set
70	SLIPPER DRIVE PULLEY, 20T	A-3269	Slipper Drive Pulley XXX-4
71	SLIPPER SPUR GEAR 92T	A-3958	92T 48P Spur Gear (Slipper) XXX-4
72	ANTENNA TIP COVER	A-4003	Antenna Caps
73	INTERNAL O-RING (CARTRIDGE)	A-5014	O-Rings For Shock Cartridge
74	MOTOR MESH WINDOW	A-3244	Access Plugs
75	TIRE, REAR	A-7372R	Rear 2.2" Taper Pin Tires (Red) w/Liner
76	TIRE, FRONT	A-7285R	Front Taper Pin Tires (Red) w/Liner
77	DRIVE BELT	A-3213	Main Drive Belt XXX-4
78	BALL JOINT, .250 X .093	A-2006	Swivel Suspension Balls
79	SHOCK SHAFT - .6"	A-5004	Front Shock Shaft, Short .6"
80	BALL STUD .168 X .38	A-6000	Rod Ends w/Balls, 4-40 x 3/8
81	BALL STUD.168 X .188	A-6001	Ball Studs w/Ends, 4-40 x 3/16
82	3/32 DIFF BALLS	A-6951	Carbide Balls, 3/32
83	SHOCK SHAFT - 1.200	A-5022	Shock Shaft 1.2"
84	SHOCK BODY, SHORT-HRD	A-5029	Anodized Shock Body, .6"
85	SHOCK BODY, X-LONG-HRD	A-5031	Anodized Shock Body, 1.2"
86	DIFF TUBE	A-3072	Tranny Diff Tube
87	OUTDRIVE CUP, STEEL	A-3073	Trans OutDrive Cup
88	HINGE PIN	A-1141	Front Bulkhead Pin Set
89	BEARING SPACER - ALUM	A-9941	Bearing Spacer/Axle Washer Set
90	AXLE WASHER - ALUM	A-9941	Bearing Spacer/Axle Washer Set
91	MACHINED DIFF SCREW	A-2909	Diff Screw, Hardware & Seal Set
92	BALL STUD 4-40 X 1/4	A-6006	Ball Studs w/Ends, 4-40 x 1/4
93	MOTOR MOUNT	A-3226	Motor Mount & Screws
94	FRONT PIVOT TH'D INSERT	A-4224	Chassis Inserts, Short/Long
95	BALLS, CHROME STEEL 5/64"	A-3099	Full Thrust Bearing Set
96	BELT TENSIONER BUSHING	A-3238	Top Shaft Set w/Hardware
97	STEERING POST	A-1542	Steering & Servo Saver Hardware
98	IDLER PULLEY SHAFT	A-3239	Belt Tensioner, Post & Hrdwre
99	TOP SHAFT	A-3238	Top Shaft Set w/Hardware
100	CARRIER/ STEERING BUSHING	A-1233	Spindle Carrier Bushings & Hardware
101	HINGE PIN FRONT INNER	A-6064	Hinge Pin 1.8" XXX-4
102	HINGE PIN, REAR INNER	A-6066	Hinge Pin 2.125" XXX-4
103	SLIPPER HUB	A-3266	Slipper Hub, Plate & Flange XXX-4
104	SLIPPER PLATE	A-3266	Slipper Hub, Plate & Flange XXX-4
105	SLIPPER FLANGE	A-3266	Slipper Hub, Plate & Flange XXX-4
106	SLIPPER BEARING SPACER	A-3265	Slipper Rebuild Kit XXX-4
107	BALL STUD, SHORT NECK .2"	A-6008	Studded Balls (.2 Short Neck) W/Ends
108	DIFF RING	A-3070	Tranny Drive Rings
109	ASSEMBLY WRENCH #2	A-6030	Assembly Wrench
110	BELT TENSIONER ARM	A-3239	Belt Tensioner, Post & Hardware
111	SERVO SAVER SPRING SM	A-1542	Steering & Servo Saver Hardware
112	SERVO SAVER SPRING LG	A-1542	Steering & Servo Saver Hardware
113	CVD KIT REAR	A-9923	CVD Set XX, XXX/4
113G	8-32 Locknut	A-6310	8-32 Aluminum Locknuts

SPARE PARTS LIST

<u>KEY #</u>	<u>KIT/PART DESCRIPTION</u>	<u>PART NO.</u>	<u>SPARE PARTS DESCRIPTION</u>
114	CVD KIT FRONT	A-9968	CVD Set-Front XXX-4
114J	8-32 Locknut	A-6310	8-32 Aluminum Locknuts
115	E-CLIP, 1/8"	A-6100	1/8" E-Clips
116	3/16 X 3/8 BEARING	A-6903	3/16 X 3/8 Bearings w/Seals
117	BEARING,5M X 8M X 2.5M	A-6907	5 X 8mm Ball Bearings
118	BEARING,1/2 X 3/4 X 5/32	A-6908	1/2" x 3/4" Sealed Ball Bearing
119	3/16X5/16 SEALED BRNG	A-6905	Ball Bearing, 3/16 x 5/16
120	ANTENNA TUBE	A-4002	Antenna Kit
121	FRONT SPRING	A-5132	2" Spring 3.2 Rate, Green
122	REAR SPRING	A-5150	2.5" Spring 2.3 Rate, Pink
123	SLIPPER SPRING	A-3265	Slipper Rebuild Kit XXX-4
124	BODY CLIP	A-8200	Body Clips
125	1/16 ALLEN WRENCH	N/A	
126	3/32 ALLEN WRENCH STD	N/A	
127	5/64 ALLEN WRENCH STD.	N/A	
128	.050 ALLEN WRENCH	N/A	
129	4-40 X 1/2 CAPHEAD	A-6204	4-40 x 1/2 Socket Head Screw
130	4-40 X 3/4 CAPHEAD	A-6205	4-40 x 3/4 Socket Head Screw
131	4-40 X 3/8 CAPHEAD	A-6206	4-40 x 3/8" SH Screws
132	4-40 X 1/4 FLATHEAD	A-6213	4-40 x 1/4 Flat Socket Screw
133	4-40 X 7/8 CAPHEAD	A-6216	4-40 x 7/8 Socket Head Screw
134	4-40 X 3/8 FLATHEAD	A-6210	4-40 x 3/8 Flat Head Socket
135	4-40 X 1/2 FLATHEAD	A-6220	4-40 x 1/2" FH Screws
136	4-40 X 5/8 CAPHEAD	A-6221	4-40 x 5/8" Cap Screws
137	SET SCREW, #4-40 X 5/8	A-4221	Body, Wing, Antenna Mounts & Battery Posts
138	4-40 X 1/4 BUTTONHEAD	A-6234	Button Head Screw,4-40x1/4
139	L/R THREADED ROD 1.625"	A-6035	Adj L/R Rods w/Ends:1.625"
140	KINGPIN SCREW	A-6235	King/Hinge Pin Screws
141	L/R THREADED ROD 1.5"	A-6033	Adj L/R Thread Rod w/Ends:1.5"
142	4-40 X 3/8" BUTTON HEAD	A-6229	4-40 x 3/8 Button Head Screws
143	4-40 X 5/16" TRI-LOB CAP	N/A	
144	4-40 X 1.5" CAPHEAD	A-4216	Motor Mount Clamp & Screws
145	2-56 X 3/16" FLAT HEAD	A-4210	Chassis Bottom Cover
146	4-40 X 5/16" BUTTON HEAD	A-6245	4-40x5/16" Button Head Screws
147	3mm X 6mm BTN HD ZINC SCW	A-6238	3x6mm Cap/Button Head Screw Kit
148	SERVO TAPE - 1-1/2" X 3"	A-4004	Servo Tape
149	THRUST WASHER - XX DIFF	A-3099	Full Thrust Bearing Set
150	WASHER BALLSTUD	A-6215	#4 Narrow Washers
151	WASHER HARDENED #4 X .030	A-6350	#4 and 1/8" Hardened Washers
152	WASHER .250 X.130X .120	A-6350	Belt Tensioner, Post & Hardware
153	SHIM, 1/4 X 5/16 X .007	A-6230	Shim Set:3/16,1/4,1/2
154	WASHER BELVIL HEAVY DUTY	A-2902	Diff Screw,Hardware & Seal Set
155	SLIPPER SHIM	A-3265	Slipper Rebuild Kit XXX-4
156	SLIPPER PUCK	A-3265	Slipper Rebuild Kit XXX-4
157	MIP LUBE	A-9933	CVD Rebuild Kit
158	MIP THREAD LOCK	A-9933	CVD Rebuild Kit
159	STICKER SHEET	A-8352	XXX-4 Sticker Sheet
160	WINDOW MASK	A-8046	XXX-4 Body W/Masks
172	SILICONE FILLED TUBE	A-3065	Losi Diff Lube
176	THREAD FORMING SCREW	N/A	See #143 Above
182	NUT, 4-40 ZINC	A-6300	4-40 Hex Nuts
183	4-40 AL LOCK NUT 3/16 HEX	A-6306	4-40 Aluminum Mini-Nuts
184	4-40 STEEL NYLOCK HALFNUT	A-6305	4-40 Lockin Nuts-Low Profile
185	FOAM THINGS	A-6003	Foam Things,Linkage Rings
186	FOAM DIFF SEAL	A-2909	Diff Screw,Hardware & Seal Set
187	FOAM, BUGGY REAR-FIRM	A-7398	R Buggy Liner,Firm
188	FOAM INSERT WIDE BUGGY FR	A-7297	Front FWD & Extra Wide Foam Tire Liners

SPARE PARTS LIST

<u>KEY #</u>	<u>KIT/PART DESCRIPTION</u>	<u>PART NO.</u>	<u>SPARE PARTS DESCRIPTION</u>
189	SILICONE SHOCK FLUID	A-5224	Silicone Shock Oil, 30Wt, 2oz.
191	GEAR COVER	A-4209	Gear Cover & Screws
192	BODY & WING,	A-8046	XXX-4 Invader Body & Wing W/Masks
193	SLIPPER WRENCH	A-3264	Slipper Rebuild Kit XXX-4
194	HINGE PIN RETAINER,	A-1234	Front Hinge Pin Retainers XXX-4
195	SET SCREW, #5-40 X 1/8	A-6228	5-40X1/8" Hardened Set Screws
196	SHIM, 3/16 X .015	A-3264	Slipper Rebuild Kit XXX-4
197	SHIM, 3/16 X .005	A-3264	Slipper Rebuild Kit XXX-4

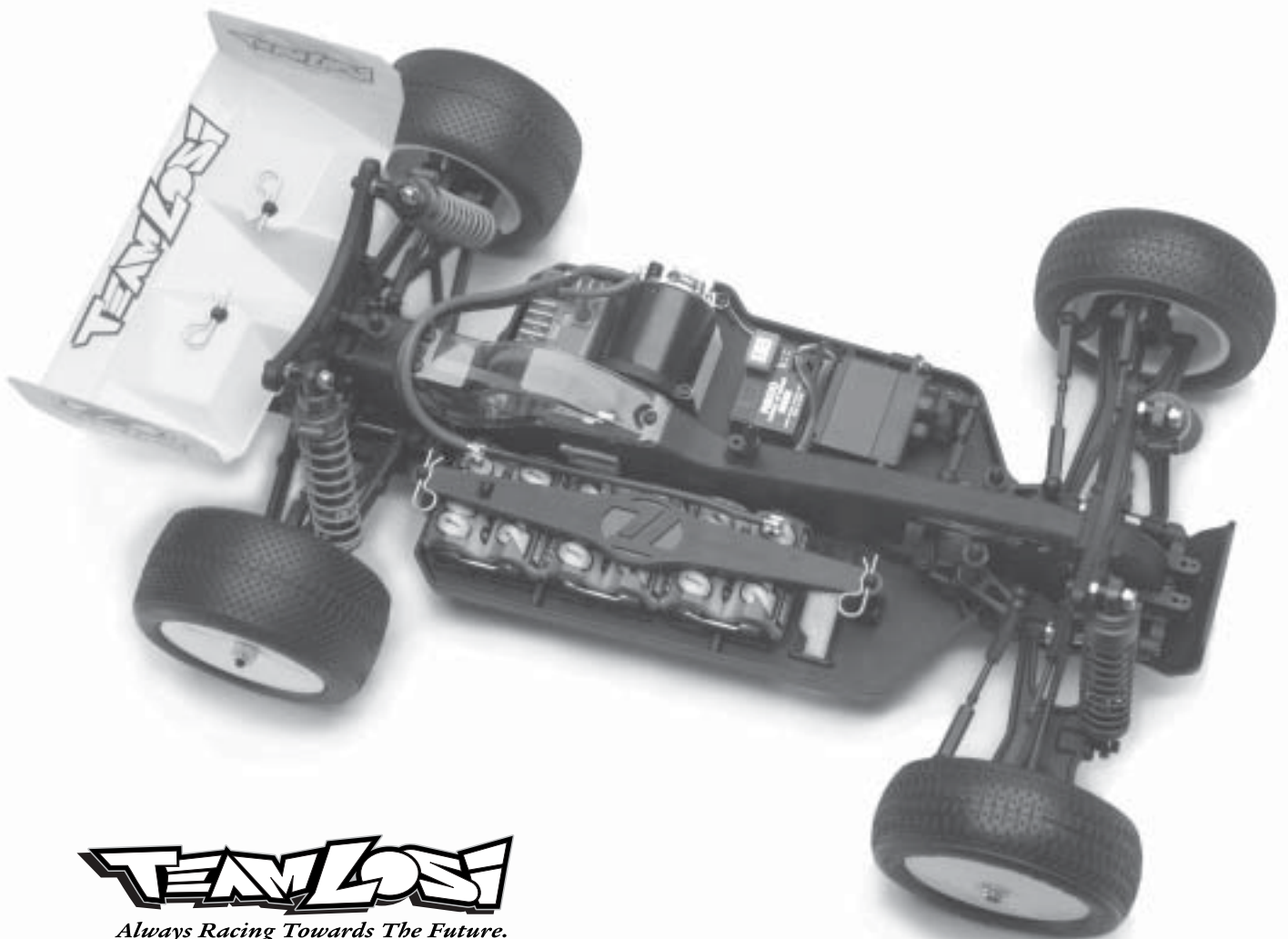

TENLOSS
Always Racing Towards The Future.