

XRAY

THE ART OF PERFORMANCE[®]



INSTRUCTION MANUAL

TTR RAYCER

1/10 HIGH COMPETITION ELECTRIC TOURING CAR



CONGRATULATIONS

The XRAY T1R Raycer is arguably the most affordable advanced 1/10-scale on-road electric touring car ever made for racing, and is based on the extremely successful XRAY T1 concept. We have used the results of thousands of hours of racing and testing on both of asphalt and carpet tracks to offer you the best car in terms of quality, performance, and price. The XRAY T1R was created by blending highest-quality materials and excellent design. The result? A very affordable, durable, high-performance racecar that is extremely easy to assemble and drive. The XRAY T1R has the racing pedigree of the XRAY T1 family and can be used for very high competition racing, but is also well suited for novice drivers who choose the XRAY T1R as their entrance into the R/C hobby.

The XRAY T1R features simplified suspension components to maximize ease of assembly and setup while offering the highest

possible performance at every kind of track. Even with the standard setup, the XRAY T1R gives a very stable, predictable driving experience. For more advanced racing and setup, we have produced a special Set-Up Book to help you understand the operation of your car and tune it for maximum performance. Setting up and tuning the XRAY T1R is extremely easy thanks to the smart design of all parts.

We have made every effort to make these instructions and Set-Up Book as easy to understand as possible. However, if you have any difficulties, problems, or questions, please do not hesitate to contact the XRAY support team at support@teamxray.com. Also, please visit our web site at www.teamxray.com to find the latest updates, setup information, option parts, and many other goodies. We pride ourselves on taking excellent care of our customers.

R/C & BUILDING TIPS

- Read and fully understand the instruction manual before building.
- Always keep this instruction manual ready at hand for quick reference, even after completing the assembly.
- Clear a work area for assembling the kit.
- Work on a light-colored towel so any dropped parts are easy to find.
- Only open bags of parts for the assembly section you are building; do not open parts bags before required.
- Make sure all screws are tight, and check them periodically. Make sure the chassis screws do not protrude below the chassis.
- For best performance, it is very important to ensure the free movement of all parts.
- Tap or pre-thread plastic parts when threading screws.

- Self-tapping screws cut threads into the parts when tightened. Do not use excessive force when tightening self-tapping screws, or you may strip out the thread in the plastic. We recommend you stop tightening a screw when you feel some resistance.

Please support your local hobby shop, and ask them for any advice. We at XRAY Model Racing Cars support all local hobby dealers. Therefore we ask you, when possible, to purchase XRAY products at your hobby dealer and give them your support as we do. If you have difficulty finding XRAY products, please check out www.teamxray.com to get advice, or contact us via e-mail at support@teamxray.com, or contact the XRAY distributor in your country.

ADDITIONAL ITEMS REQUIRED:

Radio system (transmitter and receiver), steering servo, speed controller, motor, battery pack (6-cell), pinion gear, battery charger, 1/10-scale bodyshell (190 mm), tires, inserts, double-sided tape, CA glue, bearing oil.

Receiver



Steering Servo



Speed Controller



Electric Motor



6-cell Battery Pack
(3+3 saddlepack)



190mm Bodyshell



Pinion Gear

Tire Inserts



Tires



TOOLS REQUIRED:

Cutting Pliers, Needlenose Pliers, Snap Ring Pliers, Allen Wrenches (1.5 mm, 2.0 mm, 2.5 mm, and 3.0 mm), Hobby Knife, Caster Clip Removal Tool, Turnbuckle Wrench, Shock Assembly Tool, Vernier Calipers (digital recommended), Soldering Iron and Solder. For ease of assembly, we strongly recommend using high-quality HUDY tools. For more information, see www.hudy.net.

In line with our policy of continuous product development, the exact specifications of the kit may vary. In the unlikely event of any problems with your new kit, you should contact the model shop where you purchased it, quoting the part number. We reserve all rights to change any specification without prior notice. All rights reserved.

CONTENTS

| | | | |
|---|-------|-------------------------------|-------|
| 0. KIT | 2 | 6. STEERING | 13-14 |
| 1. FRONT & REAR DIFFERENTIAL | 3-4 | 7. SHOCK ABSORBERS | 15-16 |
| 2. REAR TRANSMISSION | 5-6 | 8. REAR FINAL ASSEMBLY | 17 |
| 3. REAR SUSPENSION | 7-8 | FRONT FINAL ASSEMBLY | 18 |
| 4. FRONT TRANSMISSION | 9-10 | 9. FINAL ASSEMBLY | 19 |
| 5. FRONT SUSPENSION | 11-12 | ACCESSORY ASSEMBLY | 20-21 |

BEFORE YOU START

At the beginning of each section is an exploded view of the parts to be assembled. There is also a list of all the parts and part numbers that are related to the assembly of that section.

The part descriptions are color-coded to make it easier for you to identify the source of a part. Here are what the different colors mean:

STYLE A - indicates parts that are included in the bag marked for the section.

STYLE B - indicates parts that were set aside in Section 0.

STYLE C - indicates parts that are already assembled from previous steps.



The composite material is sensitive to very high temperatures. Prolonged exposure to very high temperatures will damage the composite and may cause it to deform. For example, do not leave the T1R in a sealed car during hot days.

0. KIT (FACTORY PREASSEMBLED)

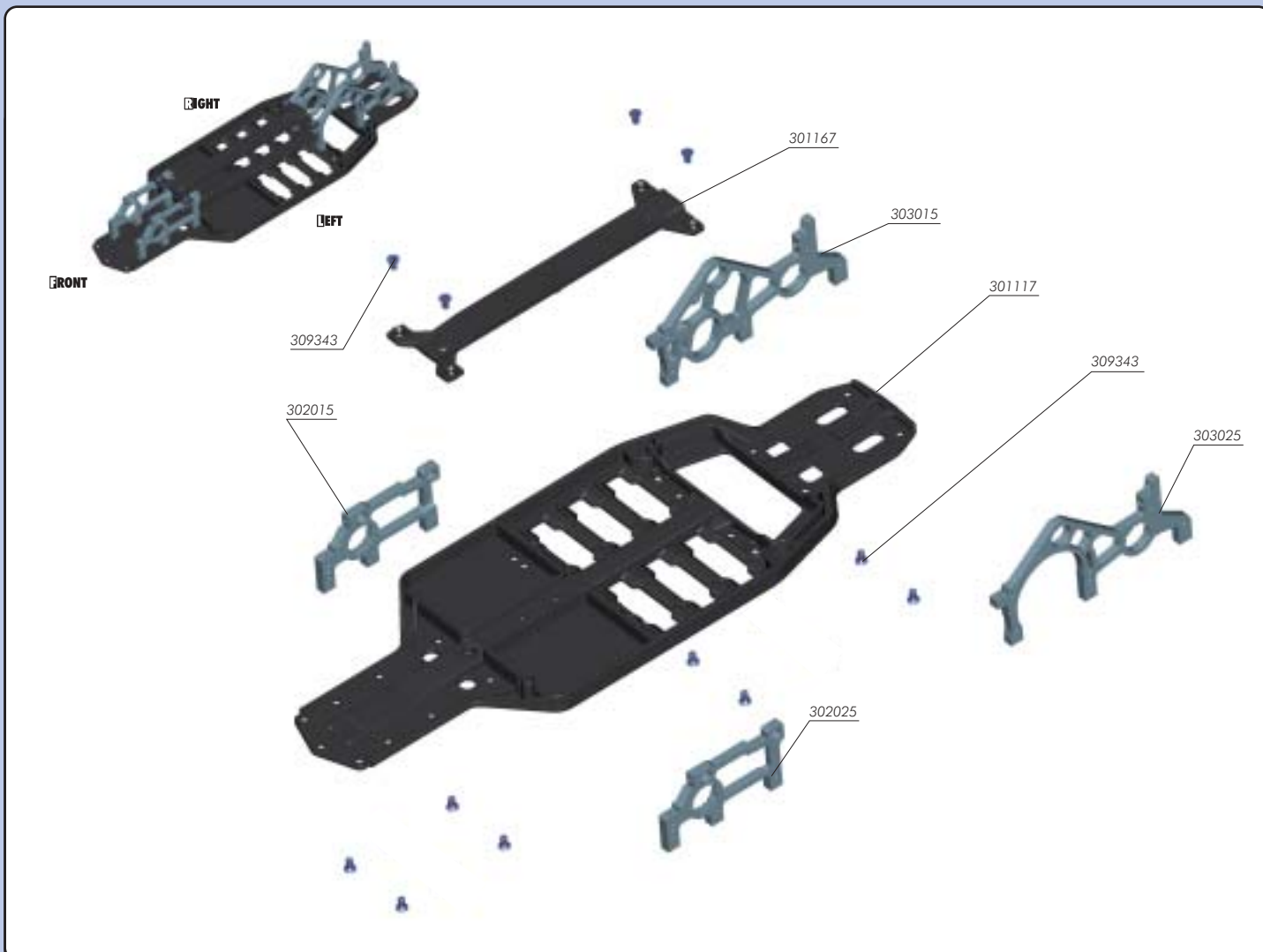

KIT

| | | | |
|---------|---|---------|--|
| 30 1117 | COMPOSITE CHASSIS | 30 3015 | ALU SUSP. ADJUSTABLE BULKHEAD REAR RIGHT |
| 30 1167 | COMPOSITE UPPER DECK | 30 3025 | ALU SUSP. ADJUSTABLE BULKHEAD REAR LEFT |
| 30 2015 | ALU SUSP. ADJUSTABLE BULKHEAD FRONT RIGHT | 30 9343 | HEX SCREW SFH M3x6 (10) |
| 30 2025 | ALU SUSP. ADJUSTABLE BULKHEAD FRONT LEFT | | |

The XRAY T1R comes partially preassembled. Before starting assembly, disassemble the chassis parts, noting the position and orientation of the parts, particularly the bulkheads. Keep the parts, including the screw hardware, close at hand. In the assembly steps that follow, each section begins with a parts list. Parts indicated with *style B* are from the previously disassembled chassis parts in section 0.

1. FRONT & REAR DIFFERENTIAL

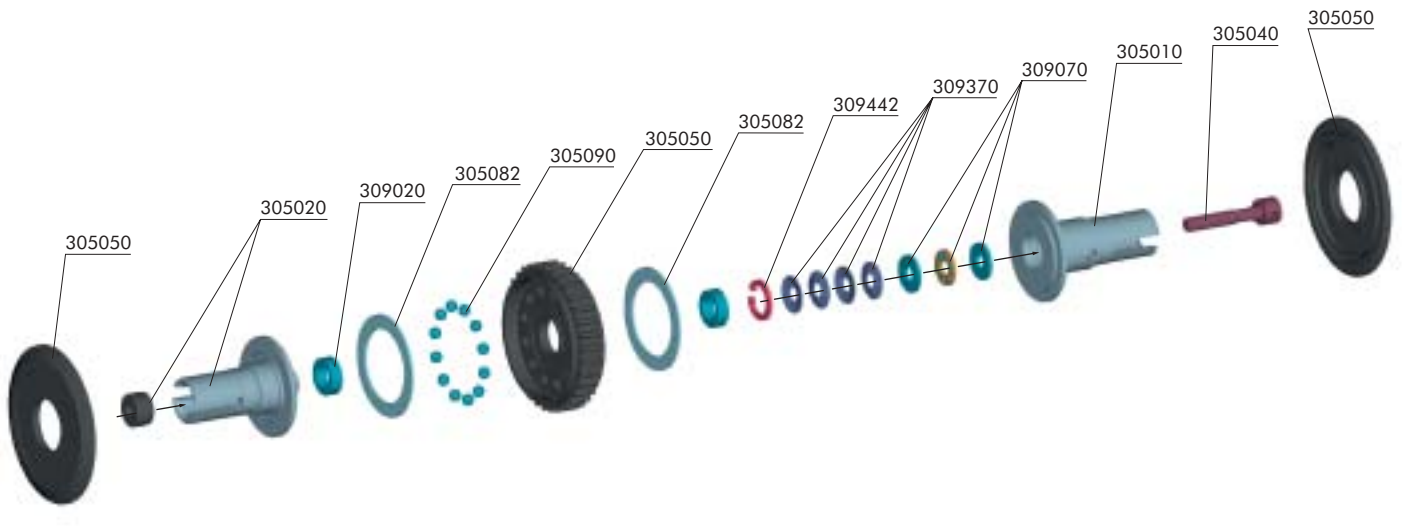

BAG 01

30 5010 ALU DIFF LONG OUTPUT SHAFT - HARD COATED
 30 5020 ALU DIFF SHORT OUTPUT SHAFT - HARD COATED
 30 5040 SCREW FOR EXTERNAL DIFF ADJUSTMENT - SPRING STEEL
 30 5050 DIFF PULLEY 34T WITH LABYRINTH DUST COVERS
 30 5082 DIFF WASHER 17x23x1 (2)

30 5090 BALL STEEL 2.4 MM (24)
 30 9020 BALL-BEARING MR85ZZ 5x8x2.5 (2)
 30 9070 BALL-BEARING AXIAL F3-8 3x8x3.5
 30 9370 CONE WASHER ST 3x8x0.5 (10)
 30 9442 CH-CLIP 8 (10)

Properly functioning differentials are extremely important to the performance of the car. It is imperative the differentials operate smoothly after assembly or rebuilding, and after every run. For differential adjustment, please refer to the Set-Up Book. You must assemble TWO complete differentials for your T1R.



309442
C 8



309370
ST 3x8



309070
BA 3x8

The long diff output shaft is preassembled at the factory. When you build your kit the first time, you can skip steps 1-5.

When you need to clean or rebuild the diff, perform the following steps.

1. Insert the smaller of the two thrust washers into the long diff shaft.
2. Apply grease to the balls in the thrust ball cage; coat each side. Insert the thrust ball cage into the long diff shaft.
3. Place the larger thrust washer into the long diff shaft.
4. Insert four cone washers as shown in the detail image.
5. Insert a #309442 (C 8) clip into the groove inside the long diff shaft. Use snap-ring pliers for easy assembly.

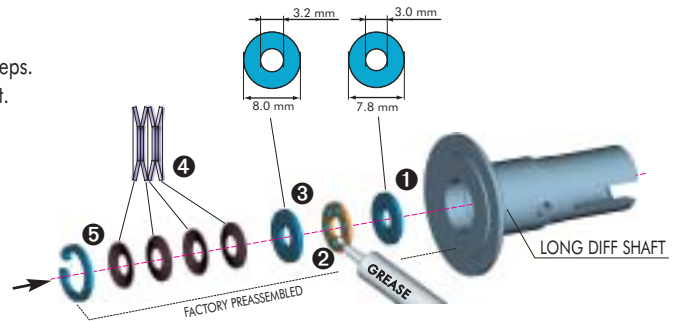

309020
BB 5x8

1. The diff locknut is pre-installed in the short diff output shaft. When you build your kit the first time, you can skip step 1.

If you need to replace the diff locknut, push it out from the opposite side with the tip of a wrench. Insert a new one into the short diff shaft.

2. Place a #309020 (BB 5x8) ball-bearing on the short center stub of the short diff shaft.
3. Put a very thin coat of grease on the side of a #305082 diff washer, and place it on the short diff shaft. The washer should seat centered on the short diff shaft. The layer of grease will hold it in place.
4. Press the #305050 diff pulley onto the ball-bearing.

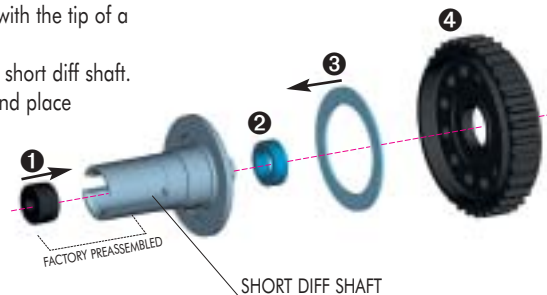

305090
B 2.4

1. Apply a little bit of grease into each of the 12 holes in the diff pulley.
2. Place the twelve #305090 diff balls into the diff pulley holes.





309020
BB 5x8

1. Hold the short diff shaft with the installed pulley facing up. Place a #309020 (BB 5x8) ball-bearing on the center stub, atop the other bearing.
2. Put a very thin coat of grease on the side of a #305082 diff washer, and place it on the long diff shaft. The washer should seat centered on the long diff shaft, and the layer of grease will hold it in place.
3. Insert the #305040 diff screw into the top of the long diff shaft as shown, and align the holes in the screw with the holes in the diff shaft. Slide a small Allen wrench through the aligned holes in both pieces. The end of the diff screw should protrude from the center of the diff shaft.
4. Hold the lower diff half upward as shown, and lower the long diff shaft with the screw pointing down onto the short diff shaft. Carefully thread the diff screw into the center of the short diff shaft. Keep tightening until the diff washer just touches the diff balls, and then tighten another 1/4 turn or until you feel some resistance. Remove the Allen wrench.

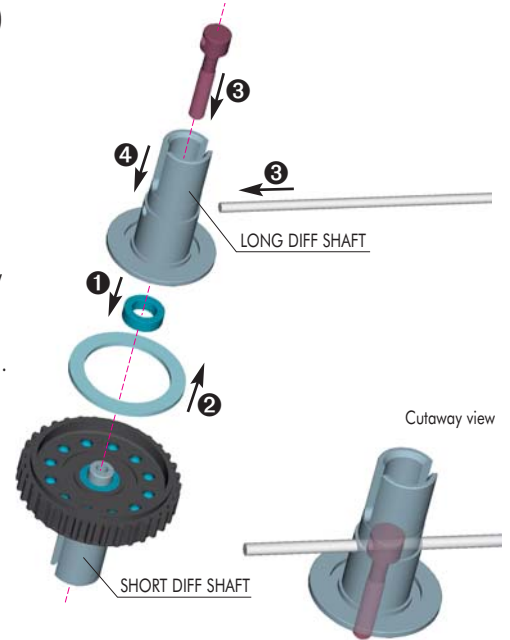

ALWAYS HOLD THE DIFFERENTIAL VERTICAL DURING ASSEMBLY, SO THE PARTS STAY IN ALIGNMENT AND THE DIFF BALLS DO NOT FALL OUT.

To check the differential:

Slide two wrenches into the slots on both sides of the diff shafts. Hold both wrenches in one hand and try to turn the pulley; it should take some force to get the pulley to slip between the two outrives. Then remove both wrenches and rotate one of the diff shafts while holding the pulley stationary. The action should feel smooth.

To tighten the differential:

Insert a small Allen wrench into the aligned holes in the setscrew and long diff shaft. Turn the long diff shaft 1/16 to 1/8 of a turn clockwise to tighten. Remove the Allen wrench and recheck the diff.

To loosen the differential:

Same as tightening the differential, except turn the long diff shaft counter-clockwise to loosen.

IMPORTANT: When you build the differential, do not tighten it fully initially; the differential needs to be broken in properly. When you build the diff tighten it very gently. When you put the diff in the car and complete the assembly, run the car for a few minutes, tighten the diff a little bit, and then recheck the diff. Repeat this process several times until you have the diff tightened to the point you want it. Final adjustments should ALWAYS be made with the diff in the car and on the track.

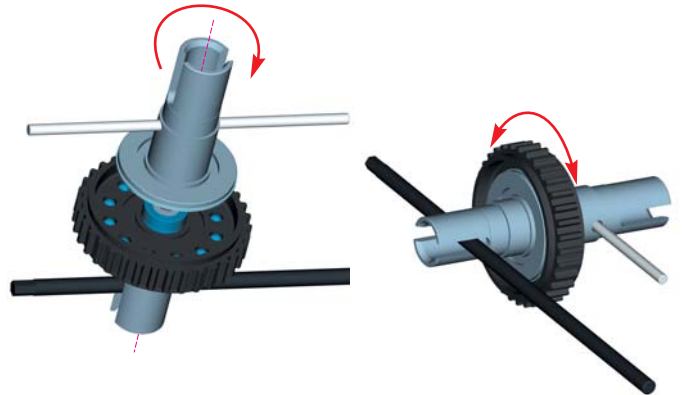

**DO NOT TIGHTEN THE DIFF COMPLETELY
THE DIFF MUST BE BROKEN IN PROPERLY !**

Slide two Labyrinth Dust Covers onto the ends of the diff shafts; the smooth sides of the covers face outward, away from the pulley. Squeeze the covers firmly until they both "snap" onto pulley; it may take a bit of effort to do this. Once snapped on, the covers seat perfectly.



Refer to the Set-Up Book to gain a better understanding of the differentials.

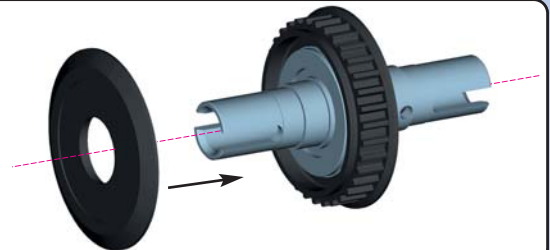

When you need to open the differential, use the shaft of a wrench to spread the dust covers apart to pop them off.

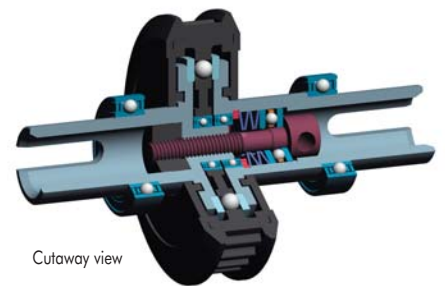
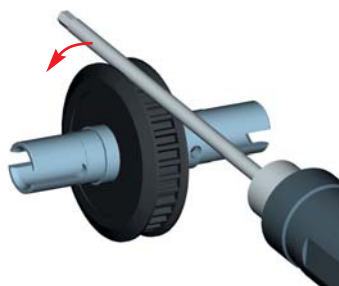

2. REAR TRANSMISSION

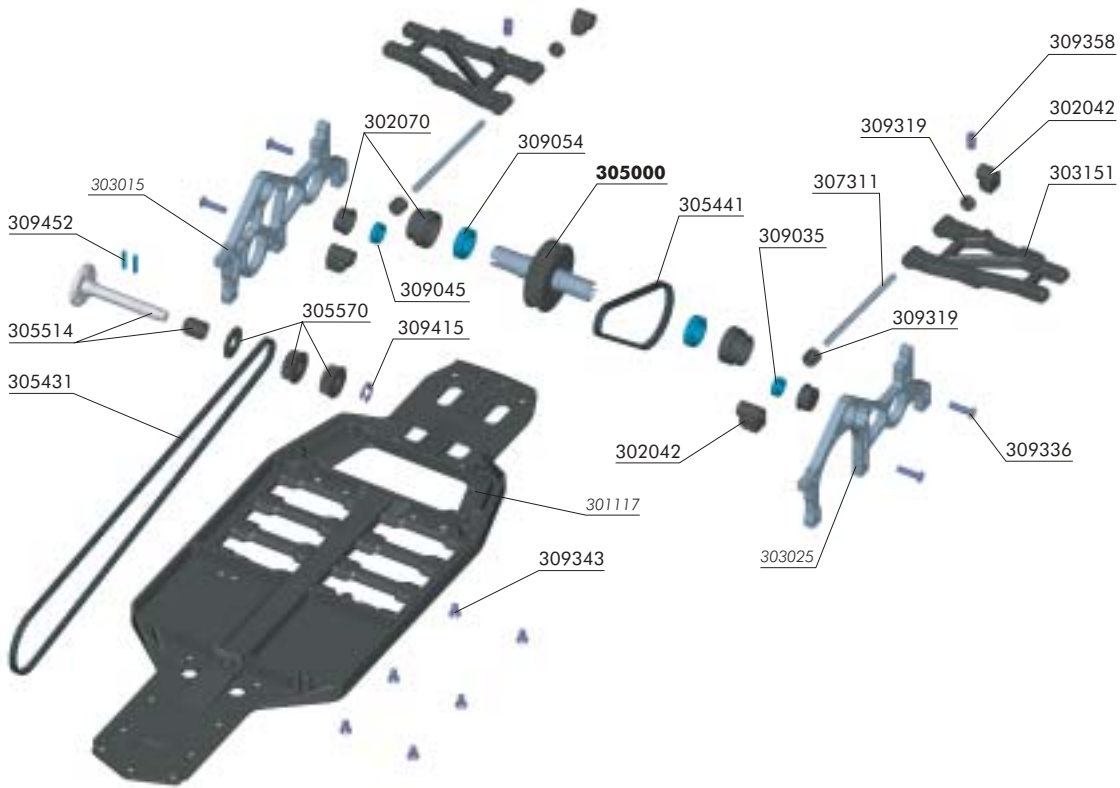

BAG 02

- 30 2042 LOWER SUSPENSION HOLDER INTEGRATED (SET 12)
- 30 2070 ECCENTRIC NYLON HUB FOR BULKHEAD + COVERS (4+2)
- 30 3151 SUSPENSION ARM - REAR LOWER - C-HUB - SOFT
- 30 5431 HIGH-PERFORMANCE KEVLAR DRIVE BELT FRONT 3 x 507 MM
- 30 5441 HIGH-PERFORMANCE KEVLAR DRIVE BELT REAR 4 x 180 MM
- 30 5514 ALU SOLID LAYSHAFT
- 30 5570 FIXED PULLEY 16T
- 30 7311 REAR WISHBONE PIVOT PIN BOTTOM - S. STEEL - C-HUB (2)
- 30 9035 HIGH-SPEED BALL-BEARING MR95ZZ 5 x 9 x 3 BLUE COVERED (2)
- 30 9045 HIGH-SPEED BALL-BEARING MR106ZZ 6 x 10 x 3 BLUE COVERED (2)
- 30 9054 HIGH-SPEED BALL-BEARING 10 x 15 x 4 BLUE COVERED (2)
- 30 9319 UNIVERSAL SET OF PLASTIC SHIMS

- 30 9336 HEX SCREW SH M3x12 (10)
- 30 9343 HEX SCREW SFH M3x6 (10)
- 30 9358 HEX SCREW SB M4x8 (10)
- 30 9415 E-CLIP 5 (10)
- 30 9452 PIN 2x10 (10)

- 30 1117 COMPOSITE CHASSIS
- 30 3015 ALU SUSP. ADJUSTABLE BULKHEAD REAR RIGHT
- 30 3025 ALU SUSP. ADJUSTABLE BULKHEAD REAR LEFT

- 30 5000 BALL DIFFERENTIAL WITH LABYRINTH DUST COVERS™ - SET



1. Press the plastic holders for the small ball-bearings into the rear bulkheads. The flange on each holder goes toward the INSIDE of the bulkhead.

The holder with a hole through it goes into the RIGHT bulkhead. The holder without a hole through it goes into the LEFT bulkhead.

2. Press a #309045 (BB 6x10) ball-bearing into the open plastic holder (with hole) in the RIGHT bulkhead. Press a #309035 (BB 5x9) ball-bearing into the closed plastic holder (without hole) in the LEFT bulkhead.

3. Press the large eccentric ball-bearing holders into the bulkheads. Align the tab of each holder with the middle notch in each bulkhead as shown. It may take some effort to press the large holders into the bulkheads.

4. Press #309054 (BB 10x15) ball-bearings into the eccentric holders.

Make sure all bearings turn freely and easily.

BELT TENSION ADJUSTMENT

To tighten rear belt:

Rotate rear nylon hubs in arrow direction (A)

To loosen rear belt:

Rotate rear nylon hubs in arrow direction (B)

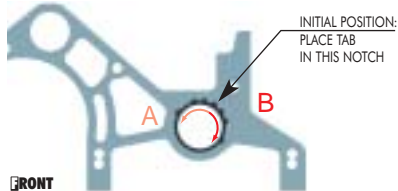

DETAIL

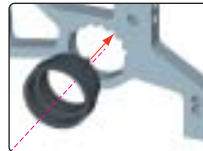

DETAIL

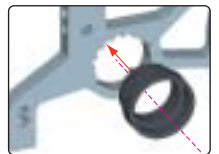

RIGHT

LEFT

Open Holder (hole)

Closed Holder (no hole)

To remove holder, press out with tool as shown.

309452
P 2x10



309415
C5



1. Insert the layshaft through the upper ball-bearing in the right rear bulkhead until the shoulder on the layshaft rests against the outside of the bearing.
2. Slide the collar over the layshaft, with the tapered end toward the bearing.
3. Slide the pulley shim over the layshaft.
4. Press a #309452 (P 2x10) pin into the layshaft hole closest to the pulley shim.
5. Slide a 16T pulley onto the layshaft, and seat it over the pin.
6. Press the other #309452 (P 2x10) pin into the other layshaft hole.
7. Slide the other 16T pulley onto the layshaft, and seat it over the second pin.
8. Snap a #309415 (C5) E-clip into the groove in the layshaft.

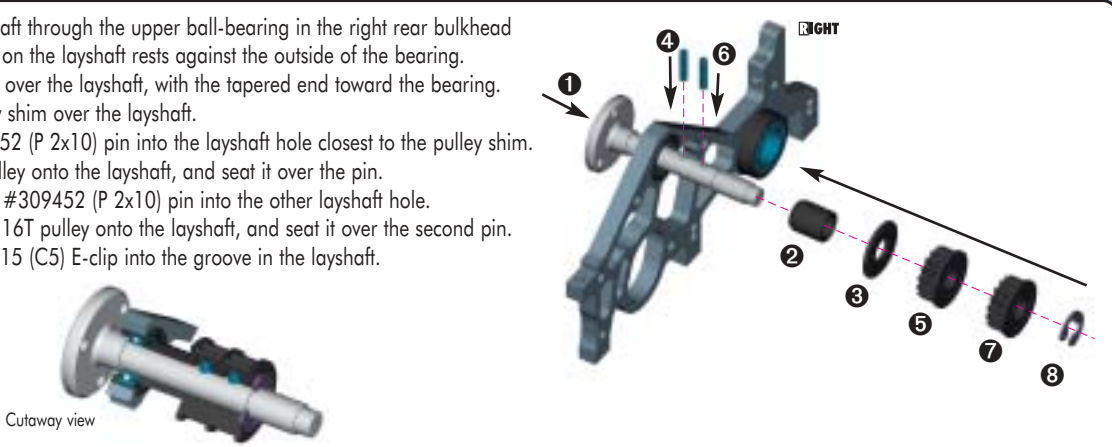

Cutaway view

309358
SB M4x8



The left and right rear lower arms are mirror images. The forward edge of each arm tapers back as it goes to the outside end. Thread #309358 (SB M4x8) screws into the holes at the rear of each rear lower arm. The screws must protrude 1.0 mm below the arms, and must be accessible from the tops of the arms for adjustment.



309336
SH M3x12







309319
SHIM 3x7x6



309319
SHIM 3x7x3



Identify the nylon holders used to mount the rear lower arms to the rear bulkheads; they are marked for easy identification. Also identify the holes in the rear bulkheads where you will mount the lower arms.

1. Mount lower suspension holders  and  to the inside front of the right and left bulkheads, respectively, using #309336 (SH M3x12) screws. Use the front upper hole in each bulkhead as shown. Do not tighten the screws; leave the holders loose.
2. Slide a #307311 pivot pin through the holes in the two rear lower arms.
3. Slide a 6mm shim onto the pins in FRONT of each rear lower arm.
4. Slide a 3mm shim onto the pins BEHIND each rear lower arm.
5. Position the rear lower arms in the rear bulkheads. Put the front ends of the pins into the front lower holders.
6. Mount lower suspension holders  and  to the ends of the pins on the right and left arms, respectively. Mount the holders to the bulkheads using #309336 (SH M3x12) screws. Use the rear lower hole in each rear bulkhead as shown. Do not tighten the screws; leave the holders loose.

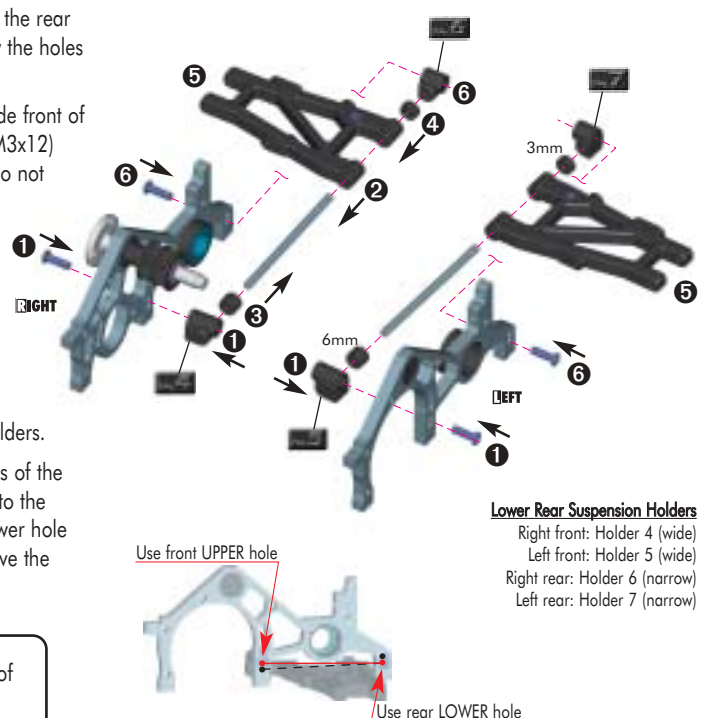

Lower Rear Suspension Holders
 Right front: Holder 4 (wide)
 Left front: Holder 5 (wide)
 Right rear: Holder 6 (narrow)
 Left rear: Holder 7 (narrow)

 Refer to the Set-Up Book to gain a better understanding of rear toe-in, wheelbase, and anti-squat.

309343
SFH M3x6



1. Mount the right rear bulkhead to the lower chassis using three #309343 (SFH M3x6) screws.
2. Place the long front drive belt on the layshaft pulley closest to the right bulkhead.
3. Place the short rear belt onto a differential.
4. Insert the longer shaft of the differential into the ball-bearing in the RIGHT bulkhead. Place the other end of the short drive belt on the layshaft's other fixed pulley.
5. Slide the left rear bulkhead into position over the other end of the differential, and mount to the lower chassis using three #309343 (SFH M3x6) screws.

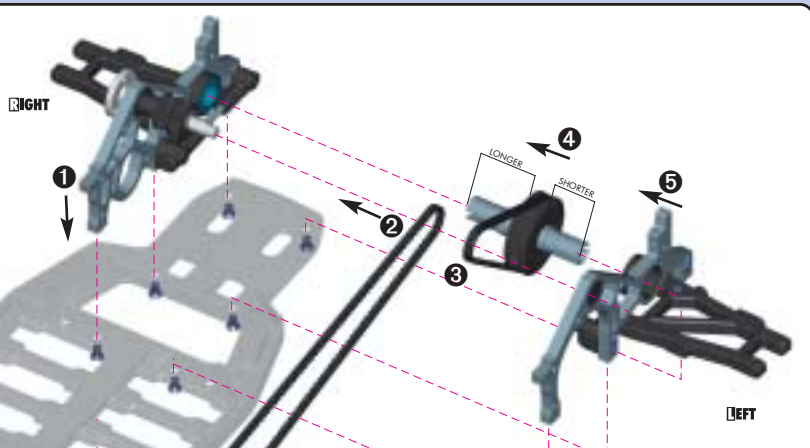

3. REAR SUSPENSION

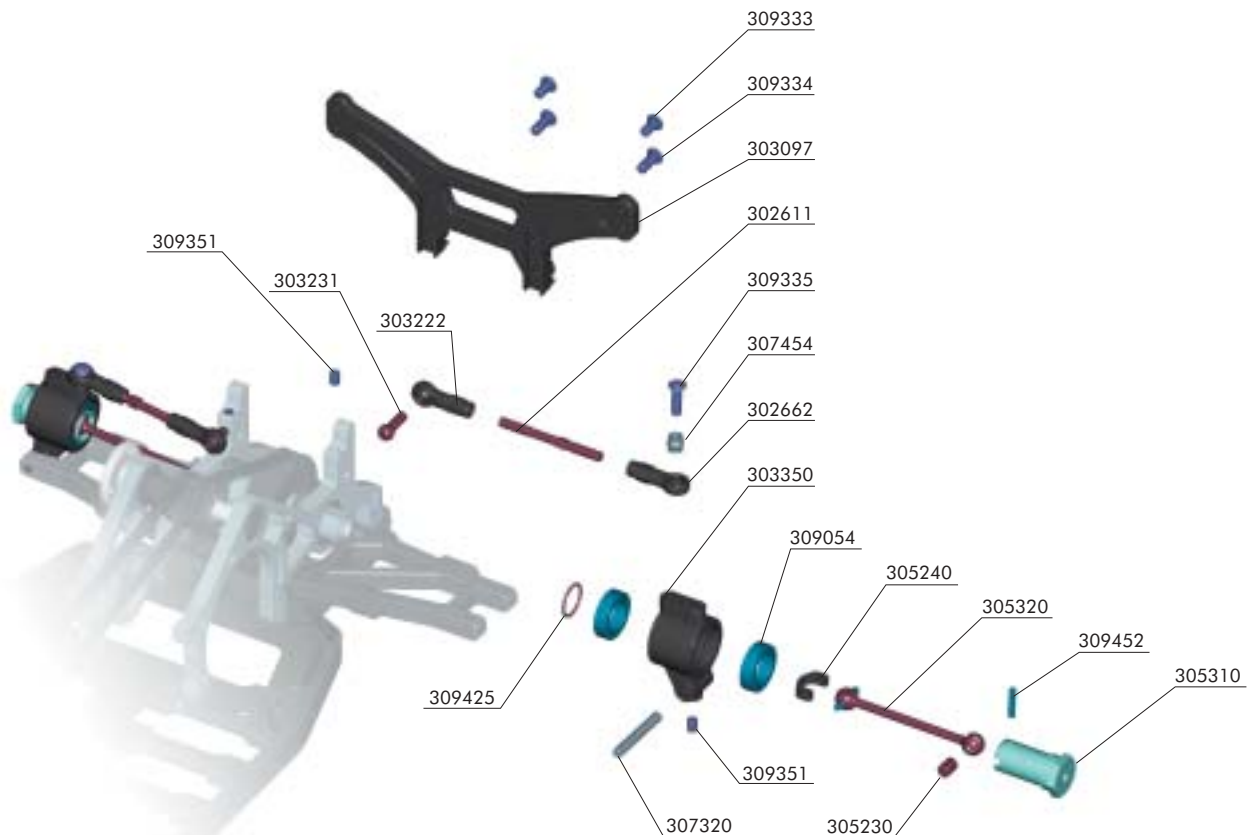

BAG 03

| | | | |
|---------|--|---------|--|
| 30 2611 | ADJ. TURNBUCKLE L/R 35 MM - SPRING STEEL (2) | 30 7320 | REAR PIVOT PIN FOR C-HUB - SPRING STEEL (2) |
| 30 2662 | BALL JOINT 5 MM - OPEN (6) | 30 7454 | PIVOT BALL 5.0 MM DOUBLE BEVEL SHOULDERS (10) |
| 30 3097 | COMPOSITE SHOCK TOWER REAR | 30 9054 | HIGH-SPEED BALL-BEARING 10 x 15 x 4 BLUE COVERED (2) |
| 30 3222 | BALL JOINT 5 MM UNIDIRECTIONAL - OPEN (4) | 30 9333 | HEX SCREW SH M3x6 (10) |
| 30 3231 | ADJUSTABLE 5 MM BALL END - SPRING STEEL (2) | 30 9334 | HEX SCREW SH M3x8 (10) |
| 30 3350 | COMPOSITE UPRIGHT REAR FOR C-HUB SUSPENSION | 30 9335 | HEX SCREW SH M3x10 (10) |
| 30 5230 | DRIVE SHAFT COUPLING - SPRING STEEL (2) | 30 9351 | HEX SCREW SB M3x4 (10) |
| 30 5240 | DRIVE SHAFT REPLACEMENT PLASTIC CAP 3 MM (4) | 30 9425 | O-CLIP 10 (10) |
| 30 5310 | WHEEL AXLE - 22 MM - INTEGR. HEX HUB - HARD COATED (2) | 30 9452 | PIN 2x10 (10) |
| 30 5320 | DRIVE SHAFT - 51 MM - SPRING STEEL (2) | | |



309452
P 2x10

Build TWO axles by performing the following steps.

1. Lightly grease a #305230 coupling and insert it into the drive shaft joint.
2. Lightly grease the drive shaft joint and slide it into the #305310 wheel axle. Align the holes in the coupling with the holes in the wheel axle.
3. Insert a #309452 (P 2x10) pin through the aligned holes in the coupling and wheel axle. Make sure the pin is evenly spaced on both sides of the wheel axle.
4. Install the plastic cap onto the drive shaft pins.

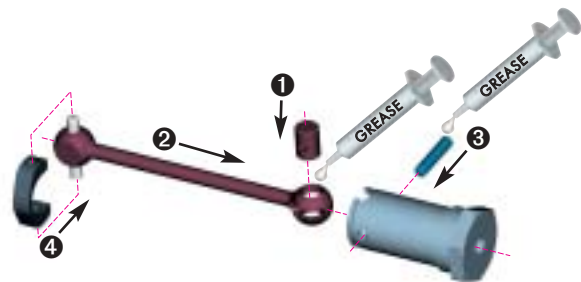

309054
BB 10x15



309425
C 10

Build TWO rear uprights by performing the following steps.

1. Slide a #309054 (BB 10x15) ball-bearing onto the wheel axle.
2. Insert the wheel axle through the rear upright until the bearing seats in the rear upright. Note the orientation of the parts in the image.
3. Slide another #309054 (BB 10x15) ball-bearing onto the wheel axle. Press the bearing into the rear upright, making sure it seats properly.
4. Secure the wheel axle in the rear upright by installing a #309425 snap ring in the groove of the wheel axle.

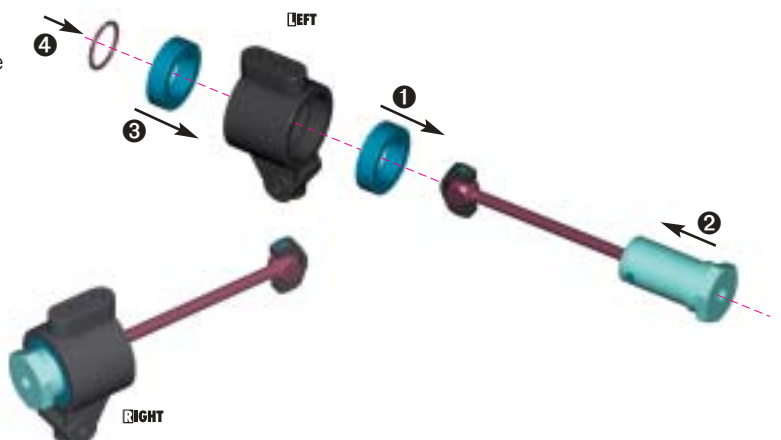

To install a snap ring:

Place the hex portion of the wheel axle flat on a table. Put one end of the snap ring into the groove on the opposite side of the axle cutout, and use a slotted screwdriver to work the clip into the groove.



To remove a snap ring:

Place the hex portion of the wheel axle flat on a table. Insert a small screwdriver in the axle cutout and pry it off, taking care not to let it fly off the workbench.

Use proper eye protection.

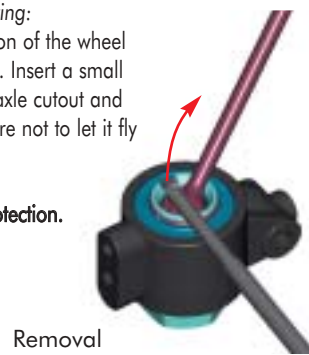

Install both rear uprights by performing the following steps.

1. Place the driveshaft plastic cap into the diff outdrive slot. Insert the rear upright into the end of the rear lower arm as shown. Align the hole in the bottom of the rear upright and holes in the arm.

2. Slide a #307320 pivot pin through the aligned holes. Make sure the flat spot on the pivot pin is toward the bottom.

3. Thread and tighten the #309351 (SB M3x4) set screw in the bottom of the rear upright until it is tight on the pivot pin. Be very careful not to overtighten the screw, as the threads may strip in the composite rear upright.

Check both rear uprights for freedom of movement.

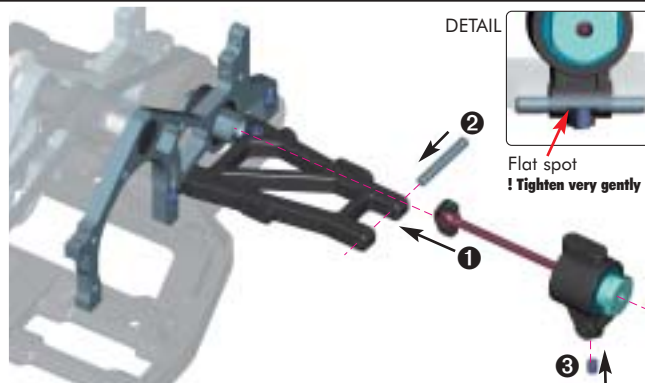

Assemble TWO rear turnbuckles by performing the following steps.

1. Thread ball joints onto the ends of a #302611 turnbuckle.

Important: There are two special #303222 unidirectional 5mm ball joints, each marked with a molded dot (see diagram). Thread these special ball joints onto the longer end of each turnbuckle. Adjust the turnbuckles to a length of 57 mm, measured end-to-end. The ball joints should be perpendicular (90°) to each other.

2. Snap a #303231 adjustable ball end into the special ball joint with the molded dot. Install the ball end into the side of the special ball joint OPPOSITE the molded dot.

Note: Each turnbuckle has a CCW thread on one end and a CW thread on the other end.



Assemble the TWO rear suspension arms by performing the following steps.

1. Place the assembled turnbuckle so the adjustable ball joint faces backward toward the rear bulkhead as shown. Place the other ball joint atop the rear upright.

2. Pass a #309335 (SH M3x10) screw downward through a #307545 pivot ball and turnbuckle ball joint, and thread into the innermost hole in the top of the rear upright. Tighten until the pivot ball snaps into the ball joint, and then tighten the whole assembly.

3. Insert the turnbuckle's adjustable ball end into the rear bulkhead until the ball end touches the bulkhead.

4. Thread a #309351 (SB M3x4) set screw into the top of the rear bulkhead to secure the ball end.

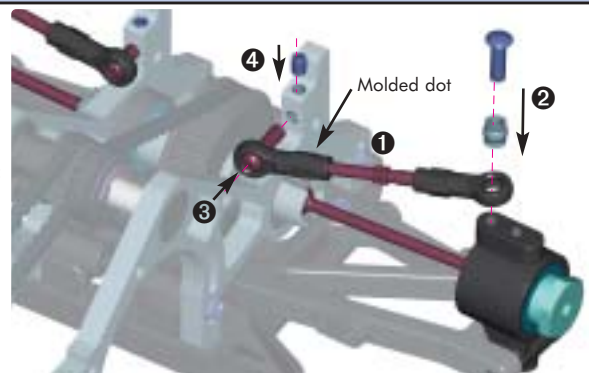

Mount the #303097 rear shock tower to the rear bulkheads with #309333 (SH M3x6) screws (in upper holes) and #309334 (SH M3x8) screws (in lower holes).



Check the rear suspension for freedom of movement. The suspension arms must fall freely when lifted up then dropped. If there is any binding that prevents the arms from moving freely, lightly squeeze the ball joints with pliers, and then recheck.

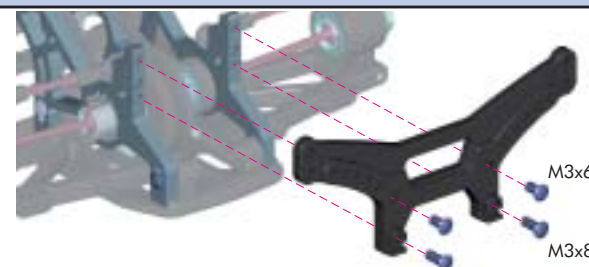

4. FRONT TRANSMISSION

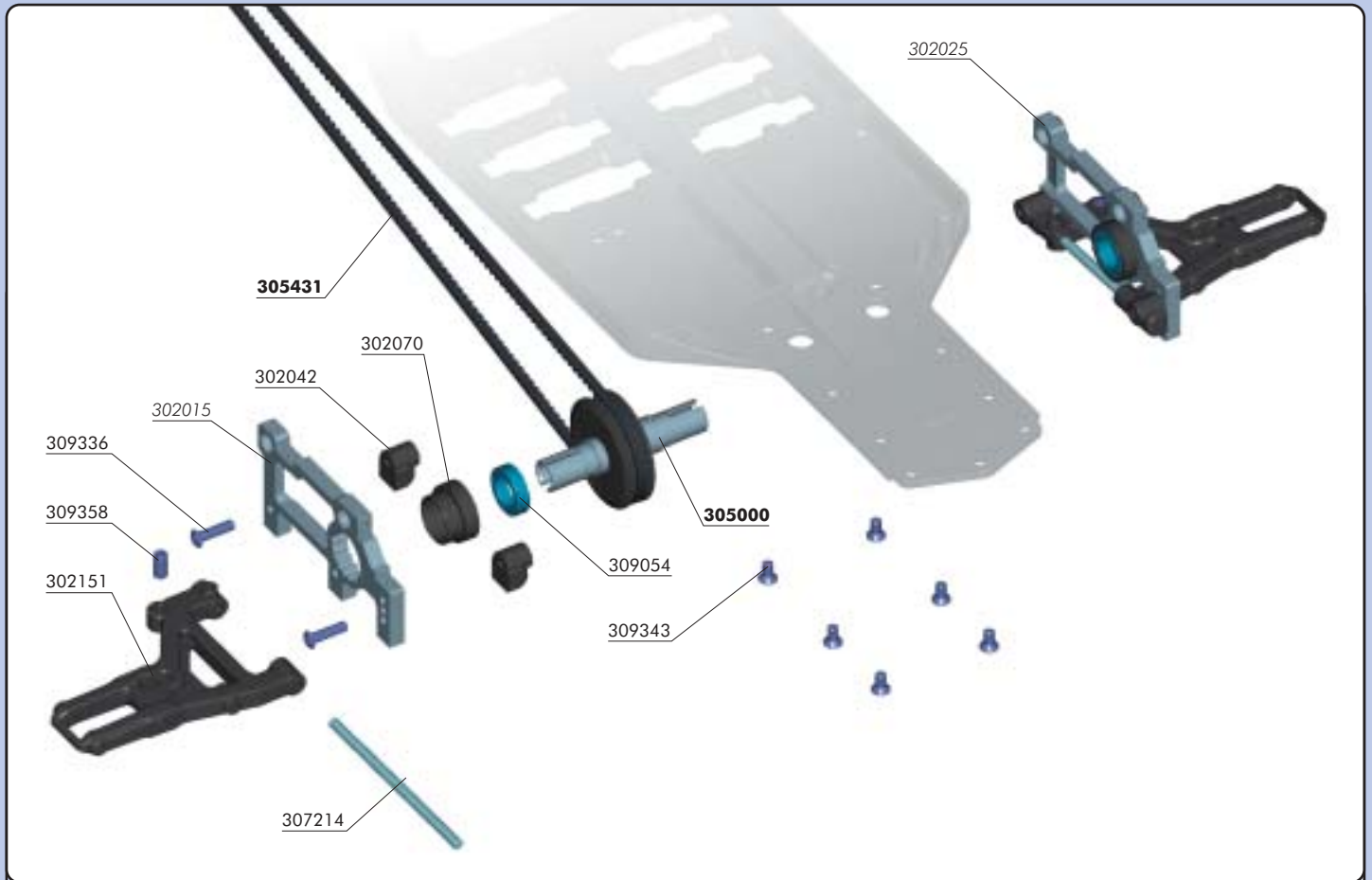

BAG 04

- 30 2042 LOWER SUSPENSION HOLDER INTEGRATED (SET 2+1+1)
- 30 2070 ECCENTRIC COMPOSITE HUB FOR BULKHEAD + COVERS (4+2)
- 30 2151 SUSPENSION ARM - FRONT LOWER - C-HUB - MEDIUM
- 30 7214 FRONT WISHBONE PIVOT PIN LOWER - SPRING STEEL (2)
- 30 9054 HIGH-SPEED BALL-BEARING 10 x 15 x 4 BLUE COVERED (2)
- 30 9336 HEX SCREW SH M3x12 (10)
- 30 9343 HEX SCREW SFH M3x6 (10)
- 30 9358 HEX SCREW SB M4x8 (10)

- 30 2015 ALU SUSP. ADJUSTABLE BULKHEAD FRONT RIGHT
- 30 2025 ALU SUSP. ADJUSTABLE BULKHEAD FRONT LEFT
- 30 9343 HEX SCREW SFH M3x6 (10)

- 30 5000 BALL DIFFERENTIAL WITH LABYRINTH DUST COVERS™ - SET**
- 30 5431 HIGH-PERFORMANCE KEVLAR DRIVE BELT FRONT 3 x 507 MM**



309054
BB 10x15

1. Press the large eccentric ball-bearing holders into the front bulkheads. Align the tab of each holder with the middle (bottom) notch in each bulkhead as shown. It may take some effort to press the large bearing holders into the bulkheads.

2. Press #309054 (BB 10x15) ball-bearings into the eccentric holders. Make sure the bearings turn freely and easily.



RIGHT

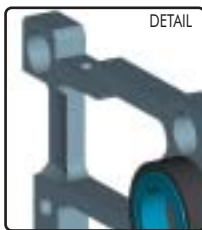

LEFT

Note machined inner edges

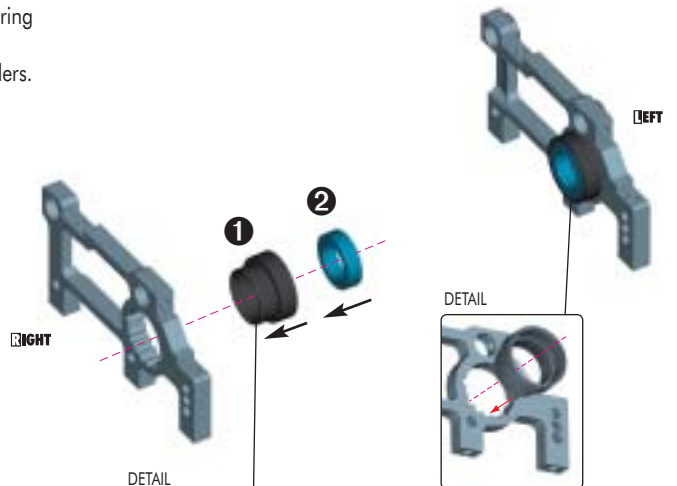

BELT TENSION ADJUSTMENT

To tighten front belt:

Rotate front nylon hubs in arrow direction (A)

To loosen front belt:

Rotate front nylon hubs in arrow direction (B)

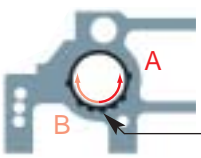

INITIAL POSITION:
PLACE TAB
IN THIS NOTCH

To remove holder, press out with tool as shown.

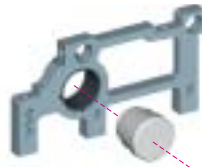



309358
SB M4x8

The left and right front lower arms are mirror images.

Thread a #309358 (SB M4x8) downstop adjustment screw into the hole at the rear of each front lower arm. The screws must protrude 1.6 mm below the arms, and must be accessible from the tops of the arms for adjustment.



309336
SH M3x12

Identify the nylon holders used to mount the front lower arms to the front bulkheads; they are marked for easy identification. Also identify the holes in the front bulkheads where you will mount the lower arms.

1. Mount lower suspension holders **Holder 3** and **Holder 2** to the inside rear of the bulkheads, using #309336 (SH M3x12) screws. The holes in the holders point toward the front.

2. Slide a #307214 pivot pin through the holes in the two front lower arms. Position the front suspension arm in the front bulkhead.

3. Insert the lower suspension holders **Holder 2** and **Holder 3** to the pins on the right and left arms, respectively. Mount the holders to the bulkheads using #309336 (SH M3x12) screws. Use the middle hole in each front bulkhead as shown.

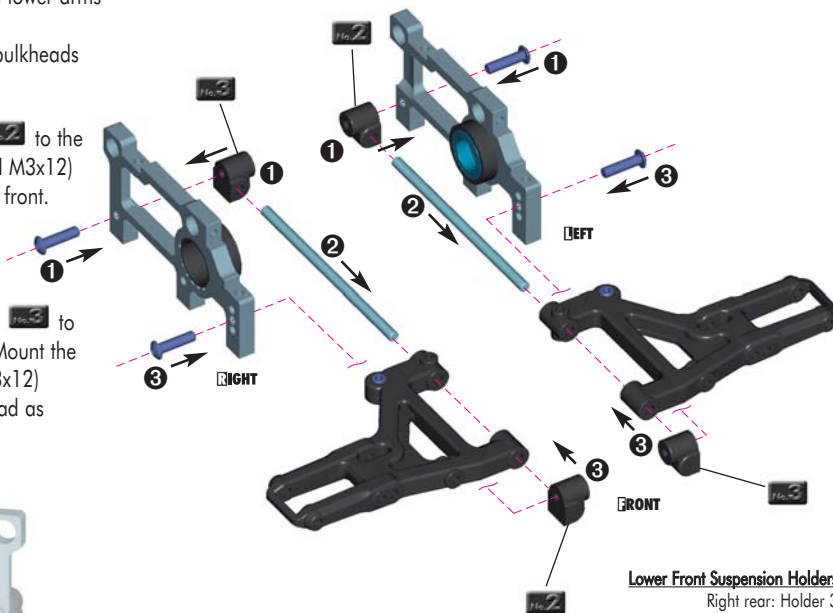
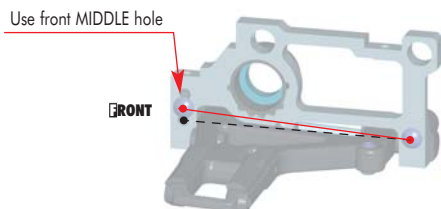

Lower Front Suspension Holders

- Right rear: Holder 3
- Left front: Holder 3
- Right front: Holder 2
- Left rear: Holder 2



309343
SFH M3x6

1. Mount the right front bulkhead to the lower chassis using three #309343 (SFH M3x6) screws.

2. Place remaining differential inside the front end of the long drive belt. Make sure the differential is oriented so the shorter diff output shaft is near the right front bulkhead.

3. Insert the shorter output shaft of the differential into the ball-bearing in the right front bulkhead.

4. Slide the left front bulkhead into position over the other end of the differential, and mount to the lower chassis using three #309343 (SFH M3x6) screws.

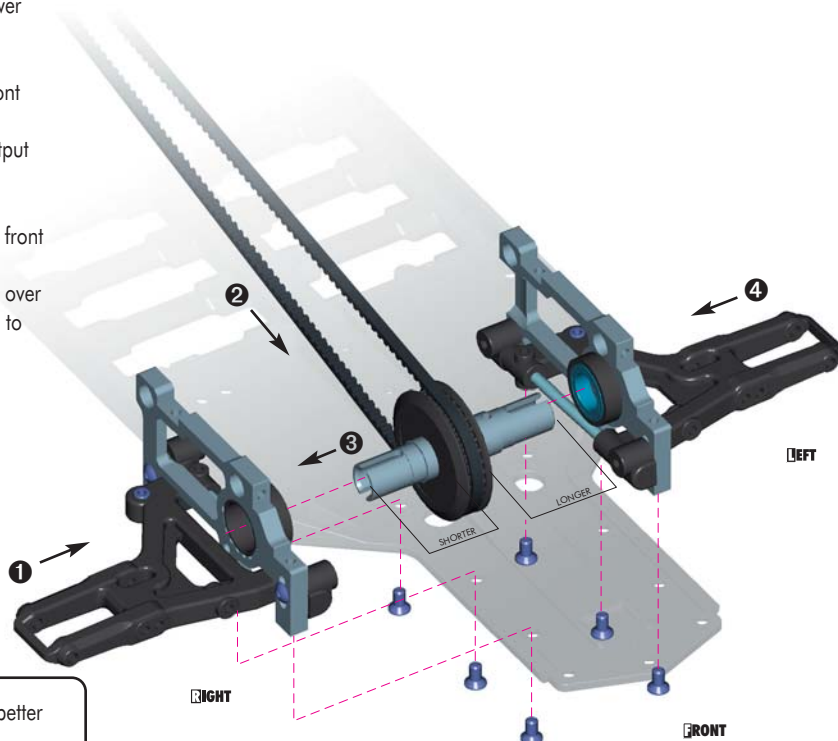

Refer to the Set-Up Book to gain a better understanding of anti-dive.

5. FRONT SUSPENSION

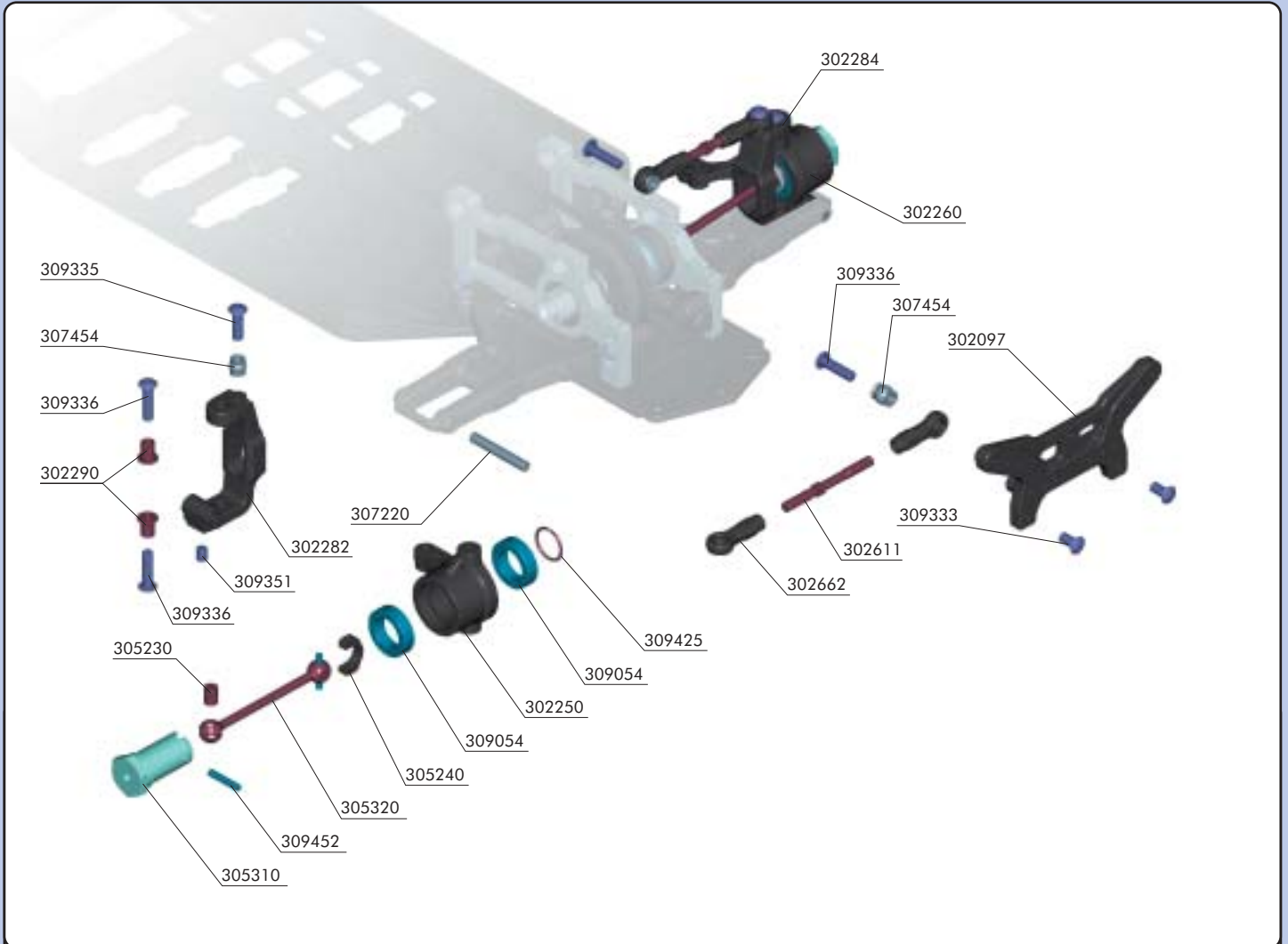

**BAG
05**

| | | | |
|---------|---|---------|--|
| 30 2097 | COMPOSITE SHOCK TOWER FRONT | 30 5320 | DRIVE SHAFT - 51 MM - SPRING STEEL (2) |
| 30 2250 | COMPOSITE STEERING BLOCK RIGHT FOR C-HUB SUSP. | 30 7220 | FRONT PIVOT PIN FOR C-HUB (2) |
| 30 2260 | COMPOSITE STEERING BLOCK LEFT FOR C-HUB SUSP. | 30 7454 | PIVOT BALL 5.0 MM DOUBLE BEVEL SHOULDERS (10) |
| 30 2282 | COMPOSITE C-HUB FRONT BLOCK, RIGHT - MEDIUM - CASTER 3° | 30 9054 | HIGH-SPEED BALL-BEARING 10 x 15 x 4 BLUE COVERED (2) |
| 30 2284 | COMPOSITE C-HUB FRONT BLOCK, LEFT - MEDIUM - CASTER 3° | 30 9333 | HEX SCREW SH M3x6 (10) |
| 30 2290 | C-HUB BUSHING (4) | 30 9335 | HEX SCREW SH M3x10 (10) |
| 30 2611 | ADJ. STEERING ROD L/R 35 MM - SPRING STEEL (2) | 30 9336 | HEX SCREW SH M3x12 (10) |
| 30 2662 | BALL JOINT 5 MM - OPEN (6) | 30 9351 | HEX SCREW SB M3x4 (10) |
| 30 5230 | DRIVE SHAFT COUPLING - SPRING STEEL (2) | 30 9425 | O-CLIP 10 (10) |
| 30 5240 | DRIVE SHAFT REPLACEMENT PLASTIC CAP 3 MM (4) | 30 9452 | PIN 2x10 (10) |
| 30 5310 | WHEEL AXLE - 22 MM - INTEGR. HEX HUB - HARD COATED (2) | | |



309452
P 2x10

Build TWO axes by performing the following steps.

1. Lightly grease a #305230 coupling and insert it into the drive shaft joint.
2. Lightly grease the drive shaft joint and slide it into the #305310 wheel axle. Align the holes in the coupling with the holes in the wheel axle.
3. Insert a #309452 (P 2x10) pin through the aligned holes in the coupling and wheel axle. Make sure the pin is evenly spaced on both sides of the wheel axle.
4. Install the plastic cap onto the drive shaft pins.

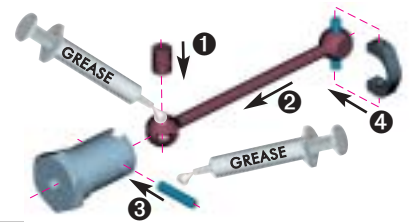

309054
BB 10x15



309425
C 10

Build TWO front steering blocks by performing the following steps.

1. Slide a #309054 (BB 10x15) ball-bearing onto the wheel axle.
2. Insert the wheel axle through the steering block until the bearing seats in the steering block. Note the orientation of the parts in the image.
3. Slide another #309054 (BB 10x15) ball-bearing onto the wheel axle. Press the bearing into the steering block, making sure it seats properly.
4. Secure the wheel axle in the steering block by installing a #309425 snap ring in the groove of the wheel axle.



To install a snap ring:

Place the hex portion of the wheel axle flat on a table. Put one end of the snap ring into the groove on the opposite side of the axle cutout, and use a slotted screwdriver to work the clip into the groove.



Installation

To remove a snap ring:

Place the hex portion of the wheel axle flat on a table. Insert a small screwdriver in the axle cutout and pry it off, taking care not to let it fly off the workbench.



Use proper eye protection.

Removal



309336
SH M3x12

Assemble the TWO front C-hubs by performing the following steps.

1. Insert two #302290 bushings into the C-hub upper and lower holes. Install the bushings from the inside of the C-hub as shown, with the flanges facing into the C-hub.
2. Insert the steering block assembly into the C-hub, passing the driveshaft through the oblong hole in the side of the C-hub. Insert the left steering block assembly into C-hub marked L, and insert the right steering block assembly into C-hub marked R.
3. Pass two #309336 (SH M3x12) screws through the bushings, and thread into the top and bottom of the steering block. The steering blocks should move freely.

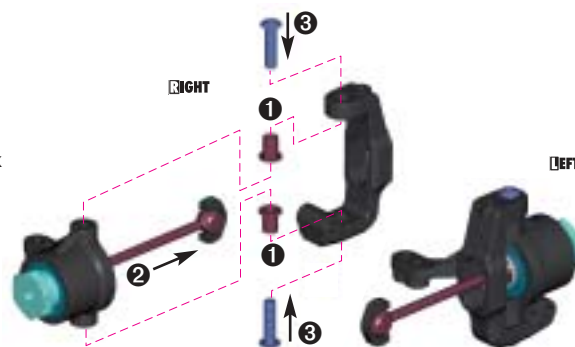

309351
SB M3x4



309333
SH M3x6

Install both front C-hub assemblies in the front lower arms by performing the following steps.

1. Place the driveshaft plastic cap into the diff outdrive slot. Insert the C-hub assembly into the end of the front lower arm as shown. Align the hole in the bottom of the C-hub and holes in the arm.
2. Slide a #307220 pivot pin through the aligned holes. Make sure the flat spot on the pivot pin is toward the bottom.
3. Thread and tighten the #309351 (SB M3x4) set screw in the bottom of the C-hub until it is tight on the pivot pin on the flat surface on it. Be very careful not to overtighten the screw, as the threads may strip in the composite C-hub. The C-hub assembly should move freely.
4. Mount the #302097 front shock tower to the bulkheads with two #309333 (SH M3x6) screws.

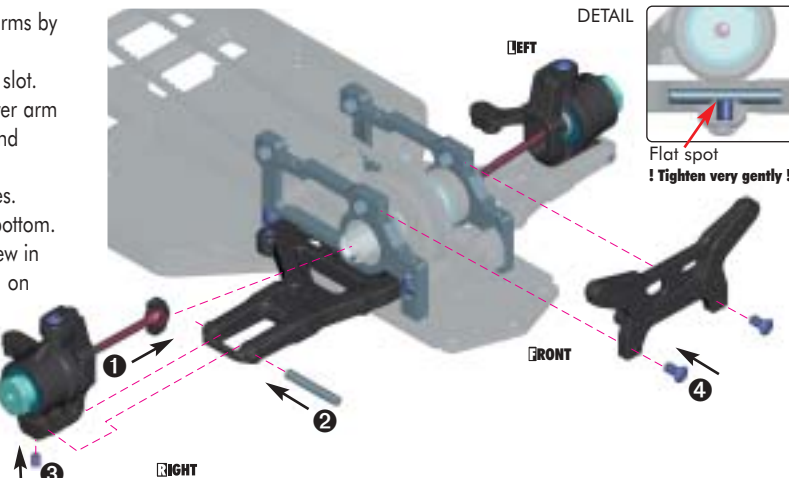

Assemble TWO front turnbuckles by threading ball joints onto the ends of a #302611 turnbuckle as shown. The ball joints should be perpendicular (90°) to each other. Adjust the turnbuckles to a length of 57 mm, measured end-to-end. Note: Each turnbuckle has a CCW thread on one end and a CW thread on the other end.

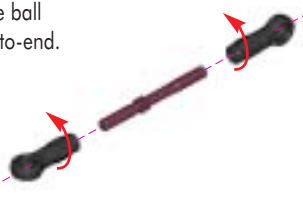
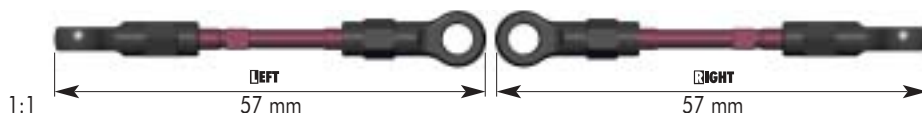

309335
SH M3x10



309336
SH M3x12



307454
PB 5 mm

Assemble TWO front suspension arms by performing the following steps.

1. Place the assembled turnbuckle between the front shock tower and C-hub as shown.
2. Pass a #309335 (SH M3x10) screw downward through a #307454 pivot ball and turnbuckle ball joint, and thread into the hole in the top of the C-hub. Tighten until the pivot ball snaps into the ball joint, and then tighten the whole assembly.
3. Pass a #309336 (SH M3x12) screw forward through a #307454 pivot ball and turnbuckle ball joint, and thread into the indicated hole at the rear of the front shock tower. Tighten until the pivot ball snaps into the ball joint, and then tighten the whole assembly.

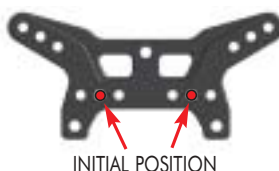

INITIAL POSITION

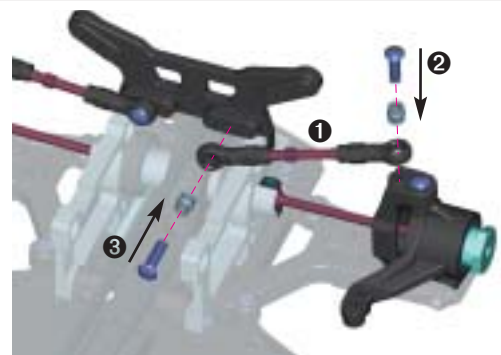

6. STEERING

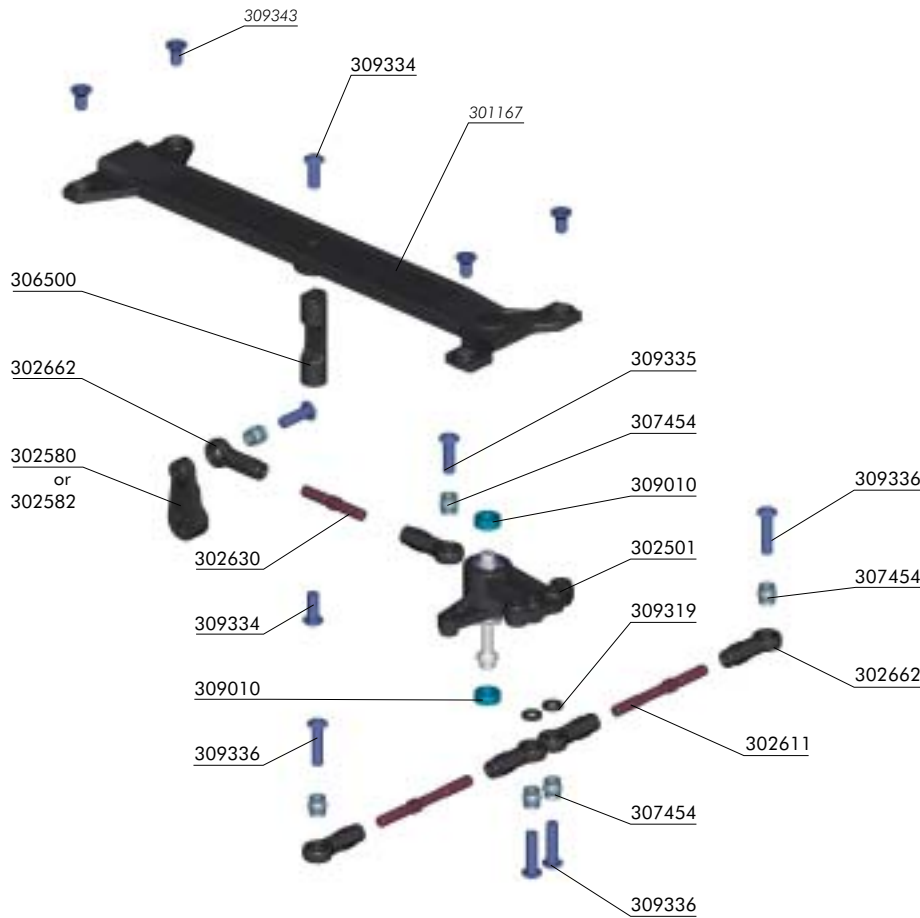

**BAG
06**

| | | | |
|---------|--|---------|--------------------------------|
| 30 2501 | DUAL-ACKERMANN CENTRAL SERVO SAVER (SET) | 30 9319 | UNIVERSAL SET OF PLASTIC SHIMS |
| 30 2580 | COMPOSITE SERVO HORN - KO, JR, AIRTRONICS, MULTIPLEX | 30 9334 | HEX SCREW SH M3x8 (10) |
| 30 2582 | COMPOSITE SERVO HORN - FUTABA, ROBE | 30 9335 | HEX SCREW SH M3x10 (10) |
| 30 2611 | ADJ. STEERING ROD L/R 35 MM - SPRING STEEL (2) | 30 9336 | HEX SCREW SH M3x12 (10) |
| 30 2630 | ADJ. STEERING ROD 20 MM - SPRING STEEL (2) | 30 9414 | E-CLIP 4 (10) |
| 30 2662 | BALL JOINT 5 MM - OPEN (6) | 30 1167 | COMPOSITE UPPER DECK |
| 30 6500 | COMPOSITE TOP DECK MOUNT | 30 9343 | HEX SCREW SFH M3x6 (10) |
| 30 7454 | PIVOT BALL 5.0 MM DOUBLE BEVEL SHOULDERS (10) | | |
| 30 9010 | BALL-BEARING MR74ZZ 4x7x2.5 (2) | | |

Assemble the right and left steering rods by threading #302262 ball joints onto the ends of #302611 turnbuckles. The ball joints should be parallel with each other. Adjust to the proper lengths as shown.

Note: Each turnbuckle has a CCW thread on one end and a CW thread on the other end.

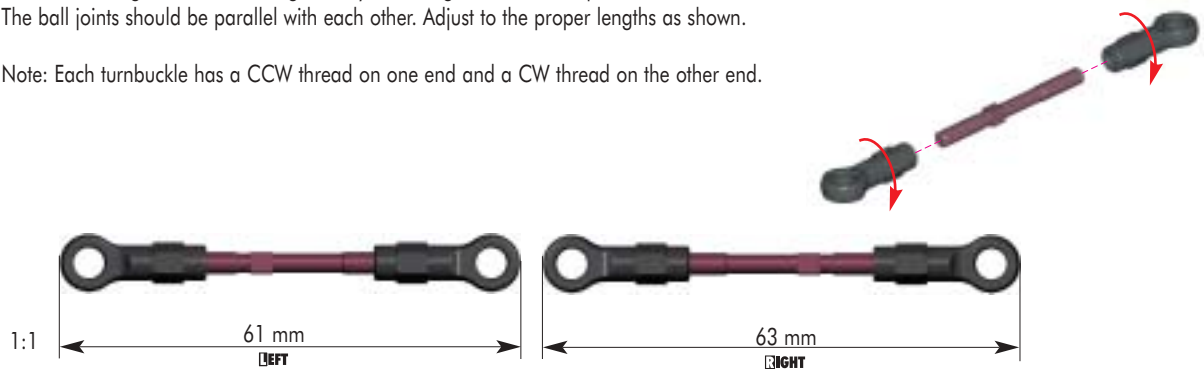

Assemble the servo link by threading ball joints onto the ends of a #302630 turnbuckle. The ball joints should be perpendicular (90°) to each other. Adjust to the proper length as shown.

Note: Each turnbuckle has a CCW thread on one end and a CW thread on the other end.

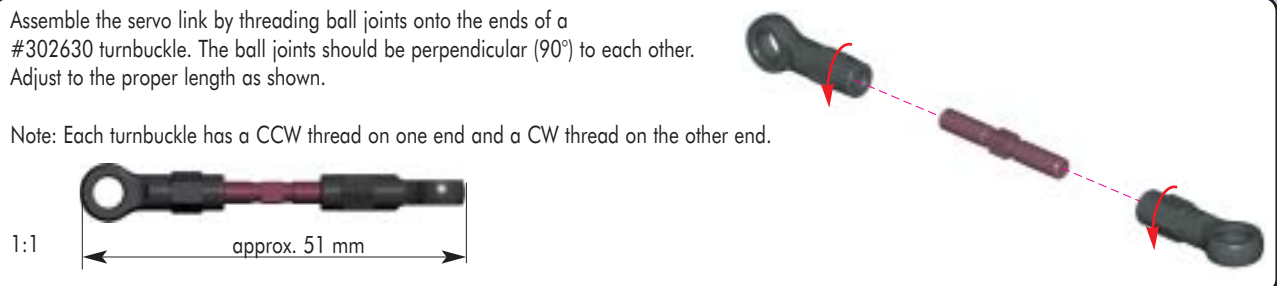

309336
SH M3x12

307454
PB 5 mm

309319
SHIM 3x5x1

309335
SH M3x10

1. Attach the left and right steering rods to the servo saver. Pass a #309336 (SH M3x12) screw upward through the following parts:
 - #307454 pivot ball
 - steering rod inner ball joint (on long end)
 - #309319 shim
 Thread the screw into the inner hole on the bottom of the servo saver. Tighten until the pivot ball snaps into the ball joint, and then tighten the whole assembly.
2. Attach the servo link to the servo saver. Pass a #309335 (SH M3x10) screw downward through a #307454 pivot ball and servo link ball joint, and thread into the servo saver side arm. Tighten until the pivot ball snaps into the ball joint, and then tighten the whole assembly.

INITIAL POSITION:
MOUNT STEERING
RODS TO INNER HOLES

309335
SH M3x10

307454
PB 5 mm

1. Choose the proper servo horn to fit your servo; see the parts list. Orient the servo horn as shown in the image.
2. Pass a #309335 (SH M3x10) screw through a #307454 pivot ball and servo link ball joint, and into the hole at the end of the servo horn. Tighten until the pivot ball snaps into the ball joint, and then tighten the whole assembly.

Check all servo saver arms for freedom of movement.

Splines for servo
on this side

309010
BB 4x7

309334
SH M3x8

309343
SFH M3x6

1. Insert a #309010 (BB 4x7) ball-bearing into the chassis.
2. Insert another #309010 (BB 4x7) ball-bearing into the top deck.
3. Position the servo saver in the chassis, and slide the steering rods through the bulkheads. Place the servo saver lower axle into the ball-bearing in the chassis.
4. Mount the top deck mount using #309334 (SH M3x8) from the bottom of the chassis. The cutout in the mount goes to the right.
5. Place the top deck atop the bulkheads. The servo saver upper axle fits into the ball-bearing in the top deck and the top deck mount will also fit into the top deck.
6. Attach the upper deck to the bulkheads using four #309343 (SFH M3x6) screws and use remaining #309334 (SH M3x8) to mount to the top deck mount.

Slide servo saver arms through bulkheads

309336
SH M3x12

307454
PB 5 mm

Attach the left and right steering rods to the steering blocks.

Pass a #309336 (M3x12) screw downward through a #307454 pivot ball and the steering rod ball joint, and thread into the steering block outer position. Tighten until the pivot ball snaps into the ball joint, and then tighten the whole assembly.

Check the steering system for freedom of movement.

INITIAL POSITION:
MOUNT STEERING
RODS TO OUTER HOLES

Refer to the Set-Up Book to gain a better understanding of steering Ackermann.

7. SHOCK ABSORBERS

ADJUSTABLE PISTONS

NON-ADJUSTABLE PISTONS

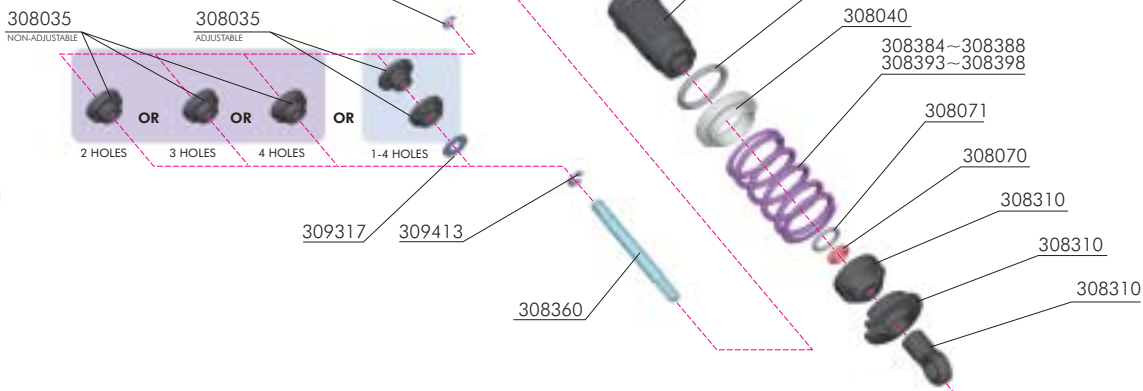
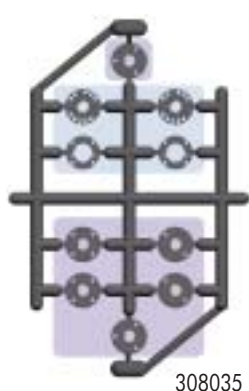

**BAG
07**

30 8035 NYLON PISTONS ADJUSTABLE + NON-ADJUST. (SET 2+6)
 30 8040 SHOCK ADJ. NUT ALU + O-RING (4+4)
 30 8070 O-RING / SHIM + C CLIPS (4+12)
 30 8071 O-RING 5x1 (4)
 30 8072 O-RING 12.1x1.6 (4)
 30 8080 SHOCKABSORBER MEMBRANES (4)
 30 8310 NYLON FRAME SHOCK PARTS 4-STEP

30 8350 SHOCK CAP-NUT ALU (2)
 30 8360 HARDENED PISTON RODS FOR KEYED PISTONS (2)
 30 8380 ADDITIONAL XRAY ULTIMATE RACING SPRINGS (20)
 30 8390 XRAY SELECTED ULTIMATE RACING SPRINGS (24)
 30 9317 WASHER S 3.2 (10)
 30 9412 E-CLIP 2 (10)
 30 9413 E-CLIP 3 (10)

Properly functioning shocks are very important to the performance of your car. This XRAY shock set contains parts to build four externally-adjustable or non-adjustable shocks. Both adjustable and non-adjustable shocks feature XRAY's unique keying system that positively locks the pistons to the shock rods.

Carefully cut the parts from the frames, and then VERY carefully trim any excess flash with a sharp hobby knife. We recommend you use extra-fine sandpaper to gently smooth small flashing. The side walls of the pistons must be perfectly round and smooth for proper operation.

We recommend you build all four shocks simultaneously. Ensure you have a clean work area to build the shocks.

ADJUSTABLE PISTONS

Apply a drop or two of shock oil to the piston pieces. Press upper piston (A) into lower piston (B) as shown. The upper piston with holes (A) has a small tab that must exactly fit into one of the notches in lower piston (B).



309413
C 2.3



309317
S 3.2



309412
C 1.9



Assemble FOUR adjustable shock rod assemblies by performing the following steps.

1. Press a #309413 (C 2.3) E-clip into the lower groove in the shock rod.
2. Place a #309317 (S 3.2) washer onto the shock rod atop the C-clip.
3. Press the piston assembly onto the shock rod, aligning flat in pistons with flat on the shock rod.
4. Press a #309412 (C 1.9) E-clip into the upper groove in the shock rod.
5. Apply a drop or two of shock oil to the piston rod assembly, and then insert the shock rod assembly into the shock body.

Cutaway view of adjustable piston

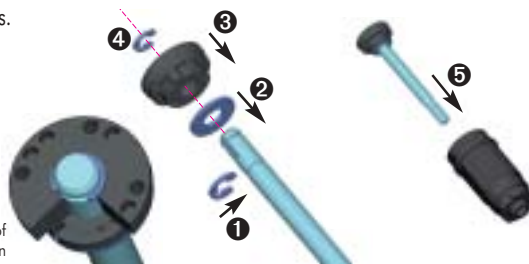

NON-ADJUSTABLE PISTONS

Assemble FOUR non-adjustable piston rod assemblies by performing the following steps. Use the 3-hole non-adjustable pistons.

1. Press a #309413 (C 2.3) E-clip into the lower groove in the shock rod.
2. Press a 3-hole piston onto the shock rod, aligning flat in piston with flat on the shock rod.
3. Press a #309412 (C 1.9) E-clip into the upper groove of the shock rod.
4. Apply a drop or two of shock oil to the piston rod assembly, and then insert the shock rod assembly into the shock body.

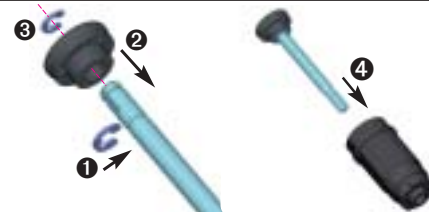

309413
C 2.3



309412
C 1.9



308072
O 12.1x1.6

- Perform the following steps for all four shocks.
1. Lubricate the inner edge of a #308072 (O12.1x1.6) O-ring with a drop or two of shock oil. Insert it into the groove of a #308040 threaded collar.
 2. Carefully thread the collar onto the shock body as shown. **Be careful not to cross-thread the collar on the shock body.**

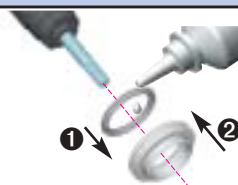

Cutaway view of assembled adjustment collar





1. Insert the larger #308071 (O 5x1) O-ring onto the shock body, until it seats around the shock body extension.
2. Lubricate the small #308070 (O 3.1x1.6) O-ring with a drop or two of shock oil. Taking care not to rip or damage the O-ring, slide it over the end of the shock rod.
3. Install the end-cap onto the bottom of the shock body. Lock it in place by pressing it on, then turning it CW about 1/8 of a turn. For easy assembly, use a #183010 HUDY Shock Assembly Tool.

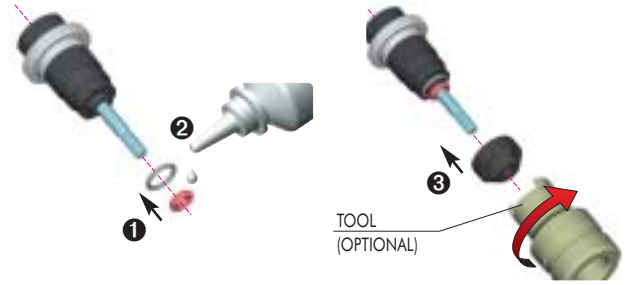

Grip the top of the shock rod's exposed thread with side-cutting pliers. Thread the ball joint onto the shock rod until approximately 1mm of thread is exposed.



HINT: Pre-thread the ball joint using an M3 screw.
WARNING! Be careful not to pre-thread too far, since the ball joint may split or the plastic threads may strip out

1. Fully extend the piston rod so the piston is at the bottom of the shock body.
2. Hold the shock upright and slightly overfill the shock body with shock oil.
3. Let the oil settle and allow air bubbles to rise to the top. Slowly move the piston up and down until no more air bubbles appear. Add shock oil as necessary.
4. Pull the piston rod most of the way out of the shock body.
5. Place the rubber bladder on top of the shock body. Some oil should spill out.
6. Move the piston out very slightly so the bladder seals against the top of the shock body.

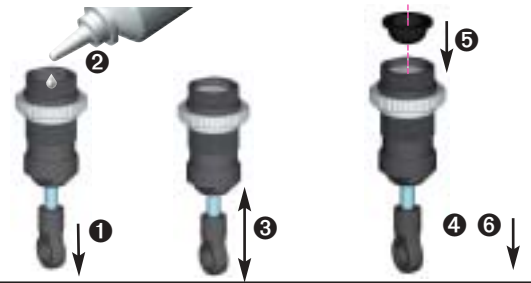

1. Place the top pivot mount on top of the bladder. Note the tab on the top pivot mount.
2. Place the #308350 collar over the top pivot mount, and thread it fully onto the shock body. More excess oil may escape. **Ensure the notch in the collar fits over the tab on the top pivot mount.**



Shock bleeding:

Turn the shock upside down and pull the shock rod out to full extension. Release the shock end-cap by turning it CCW and pulling it slightly away from the shock body. Let the shock "vent" for at least 10 minutes; excess oil should seep out the end of the shock body. If the shock rod doesn't retract slightly into the shock body, push it in by 1~2mm. Replace the end-cap.

Check the shock for proper operation. The shock rod must move in and out freely with only "hydraulic" dampening. The shock rod should not extend out by itself when pushed in and released, nor should it be drawn into the shock body when extended and released. If this happens, reopen the shock, refill with oil, reassemble, and repeat the bleeding procedure.

Shock length adjustment:

It is VERY important that all shocks are equal length. Fully extend the shock absorber and measure the end-to-end length; we recommend using digital calipers to give an accurate measurement. If a shock absorber is shorter or longer than others, adjust the shock length by tightening or loosening the ball joint on the shock rod.

Damping adjustment:

If you built the adjustable shocks, fully extend the shock rod and turn it slightly to lock the piston in the shock body.

Turning the shock rod fully CCW aligns 4 holes in the pistons (softest damping). Turning the shock rod fully CW aligns 1 hole in the pistons (hardest damping). The shocks have four settings, each of which can be felt by a slight "click".

Set all four shocks initially to position 3 (3 holes open).

Cutaway view of assembled shock absorber

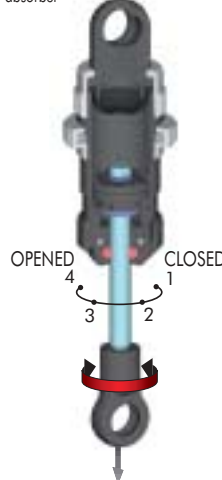

Final shock assembly:

1. Slide a spring onto the end of the shock.
2. Secure the spring with a spring cup, and settle the spring cup on the ball joint.



FRONT
(Violet springs)

REAR
(Blue springs)



8. REAR FINAL ASSEMBLY

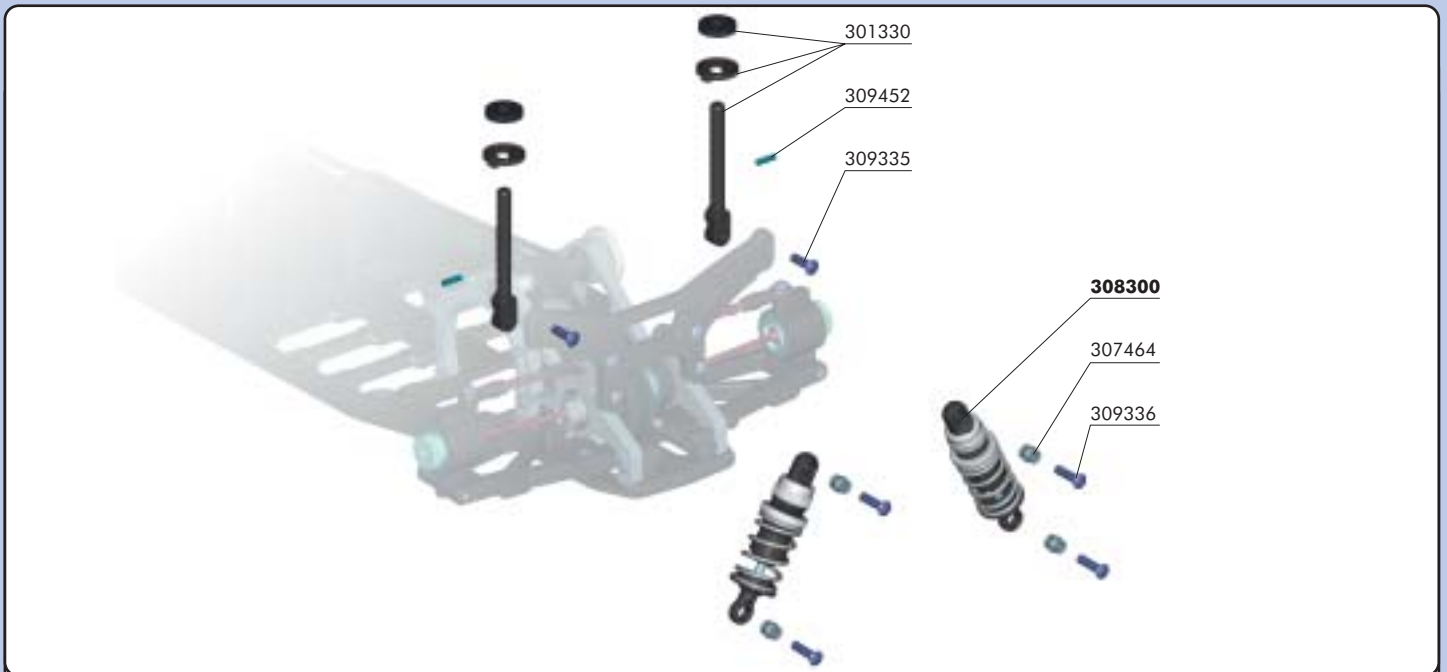

BAG 08

30 1330 REAR BODY MOUNT SET
 30 7464 PIVOT BALL 5.8 MM DOUBLE BEVEL SHOULDERS (10)
 30 9335 HEX SCREW SH M3x10 (10)
 30 9336 HEX SCREW SH M3x12 (10)

30 9452 PIN 2x10 (10)
 30 8300 XRAY SHOCK ABSORBER-SET 4-STEP (2)

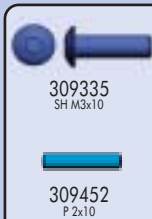

Assemble TWO rear body posts by performing the following steps.

1. Mount the body post to the front of the rear shock tower. The bottom plastic pin fits into the lower hole. Use a #309335 (SH M3x10) screw to fasten each body post to the shock tower.
2. Insert a #309452 (P 2x10) pin into one of the holes in a rear body post. Insert the other pin into the same hole in the other body post.
3. Glue a rubber washer to the top of a plastic body support.
4. Slide the body support onto the body post, and snap onto the pin.

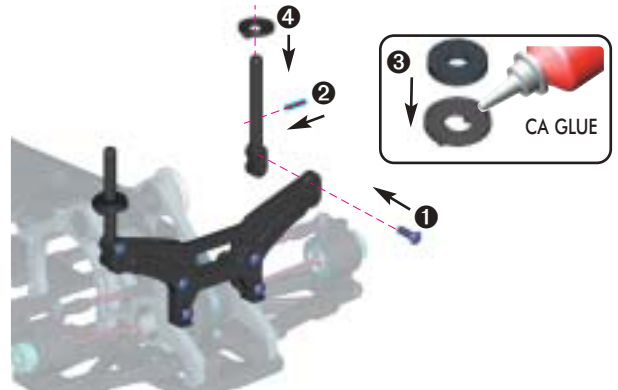

Attach TWO rear shocks by performing the following steps.

1. Attach the top of the rear shock to the rear shock tower. Pass a #309336 (SH M3x12) screw through a #307464 pivot ball and shock upper mount, and thread into the indicated hole in the rear shock tower. Tighten until the pivot ball snaps into the shock upper mount, and then tighten the whole assembly.
2. Attach the bottom of the rear shock to the rear lower arm. Pass a #309336 (SH M3x12) screw through a #307464 pivot ball and shock lower ball joint, and thread into the indicated hole in the rear lower arm. Tighten until the pivot ball snaps into the shock lower ball joint, and then tighten the whole assembly.

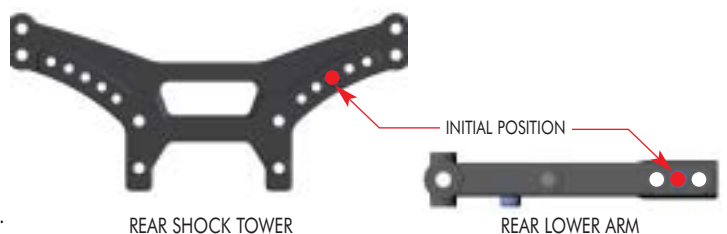
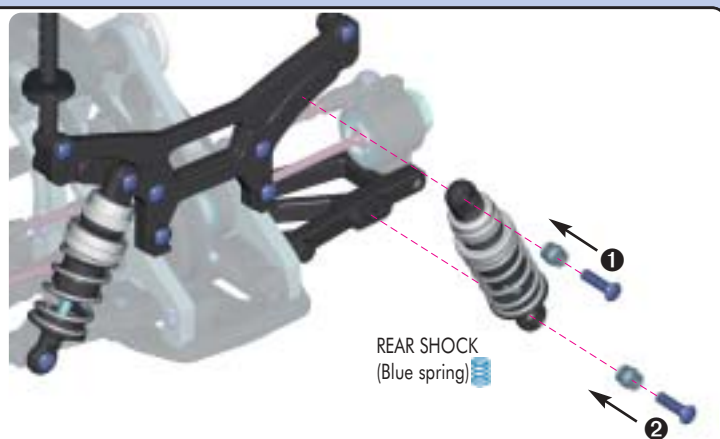

Refer to the Set-Up Book to gain a better understanding of different shock mounting locations.

REAR SHOCK TOWER

REAR LOWER ARM

8. FRONT FINAL ASSEMBLY

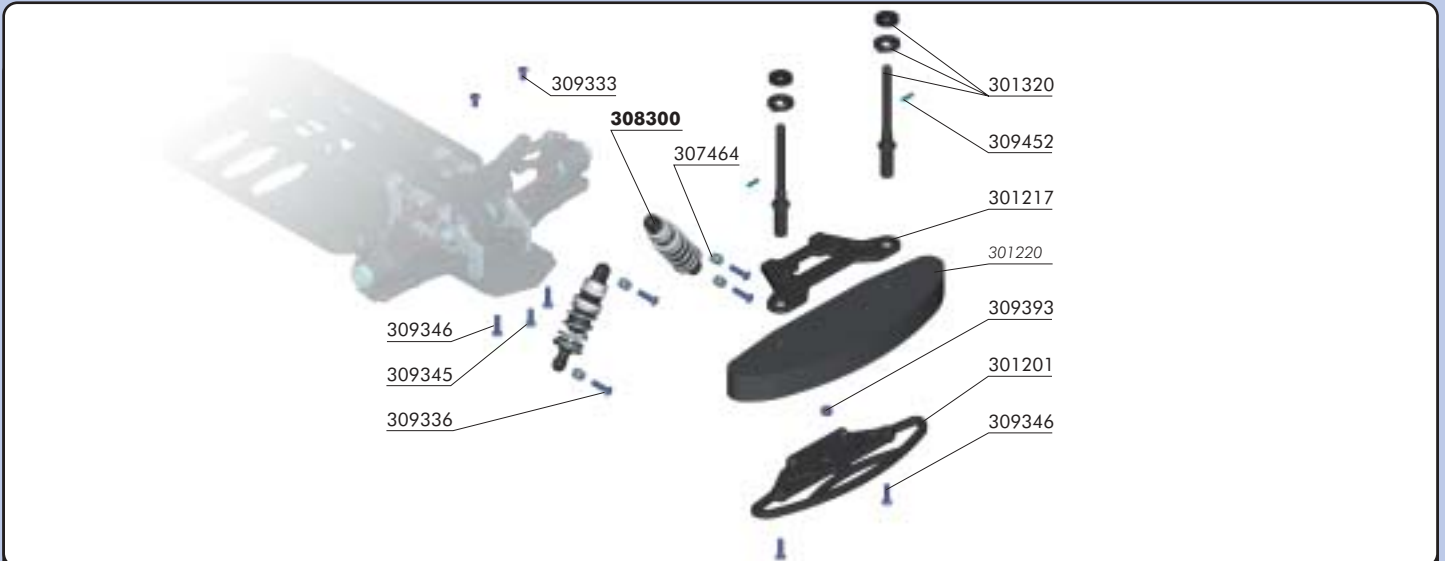

| | | | | |
|---------------|---------|---|---------|------------------------------------|
| BAG 08 | 30 1201 | IMPACT ABSORBING FRONT BUMPER | 30 9346 | HEX SCREW SFH M3x12 (10) |
| | 30 1217 | COMPOSITE UPPER BUMPER SUPPORT | 30 9393 | NUT M3 (10) |
| | 30 1320 | FRONT BODY MOUNTS (SET) | 30 9452 | PIN 2x10 (10) |
| | 30 7464 | PIVOT BALL 5.8 MM DOUBLE BEVEL SHOULDERS (10) | 30 1220 | FOAM BUMPER |
| | 30 9333 | HEX SCREW SH M3x6 (10) | 30 8300 | XRAY SHOCK ABSORBER-SET 4-STEP (2) |
| | 30 9336 | HEX SCREW SH M3x12 (10) | | |
| | 30 9345 | HEX SCREW SFH M3x10 (10) | | |

- Place a #309393 (N M3) nut into the hex recess atop the #301201 lower bumper.
- Place the lower bumper onto the front of the chassis.
- Thread a #309345 (SFH M3x10) screw up through the bottom of the chassis, through the bumper, and into the M3 nut.
- Thread two #309346 (SFH M3x12) screws up through the bottom of the chassis and into the lower bumper.

- Insert the front body posts into the holes of the #301217 upper bumper support.
- Slide the #301220 foam bumper up onto the body posts; the posts should extend down through the foam bumper.
- Position the bumper assembly onto the lower bumper.
- Secure the body posts to the lower bumper by threading two #309346 (SFH M3x12) screws upward through lower bumper into the bodyposts.
- Secure the upper bumper support to the front bulkheads with two #309333 (SH M3x6) screws.
- Glue rubber washers to the tops of the plastic body supports.
- Insert a #309452 (P 2x10) pin into a hole in a front body post. Insert the other pin into the same hole in the other body post.
- Slide the body supports into the body posts, and snap onto the pins.

Attach TWO front shocks by performing the following steps.

- Attach the top of the front shock to the front shock tower. Pass a #309336 (SH M3x12) screw through a #307464 pivot ball and shock upper mount, and thread into the indicated hole in the front shock tower. Tighten until the pivot ball snaps into the shock upper mount, and then tighten the whole assembly.
- Attach the bottom of the front shock to the front lower arm. Pass a #309336 (SH M3x12) screw through a #307464 pivot ball and shock lower ball joint, and thread into the indicated hole in the front lower arm. Tighten until the pivot ball snaps into the shock lower ball joint, and then tighten the whole assembly.

Refer to the Set-Up Book to gain a better understanding of different shock mounting locations.

9. FINAL ASSEMBLY

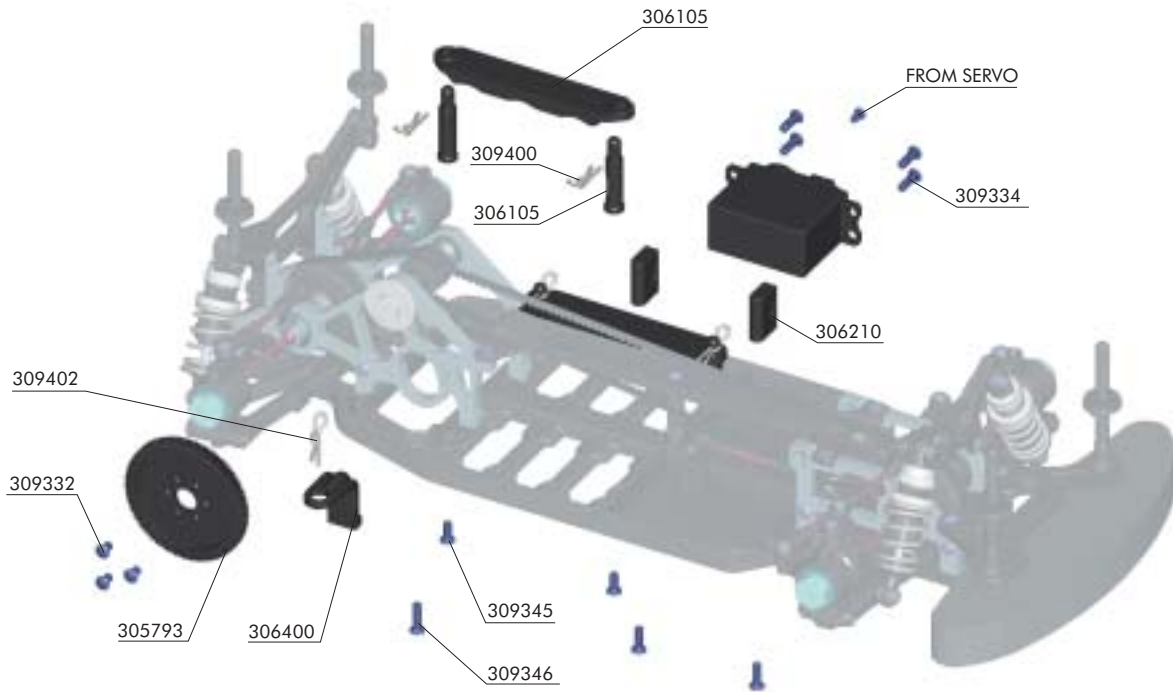

**BAG
09**

30 5793 SPUR GEAR 93T / 48
 30 6105 COMPOSITE BATTERY HOLDERS FOR 2 x 3 BAT. - COMPLETE SET
 30 6210 COMPOSITE SERVO MOUNT (2)
 30 6400 COMPOSITE TRANSPONDER MOUNT
 30 9332 HEX SCREW SH M3x5 (10)

30 9334 HEX SCREW SH M3x8 (10)
 30 9345 HEX SCREW SFH M3x10 (10)
 30 9346 HEX SCREW SFH M3x12 (10)
 30 9400 BODY CLIP (8)
 30 9402 CLIP FOR TRANSPONDER (4)



309345
SFH M3x10

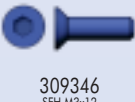

309346
SFH M3x12



309334
SH M3x8

1. Mount four #306105 battery holder posts to the chassis with #309345 (SFH M3x10) screws. Orient the cutouts in the mounts so the battery pack will fit in the cutouts.

2. Place the #306105 battery straps onto the posts, the molded 'F' symbol should be towards the front of the chassis. Secure with #309400 clips.

3. Mount the #306400 transponder mount to the chassis with a #309346 (SFH M3x12) screw.

Before participating in a race event, review the rules to determine the accepted transponder mounting locations.

4. Attach the servo to the #306210 servo mounts using four #309334 (SH M3x8) screws.

5. Attach the servo mounts to the chassis using two #309345 (SFH M3x10) screws.

6. Attach the servo horn to the servo using the screw that comes with the servo. Refer to the Set-Up Book for steering adjustment.

If the servo does not fit properly, you may have to add shims between the servo tabs and the mounting posts.

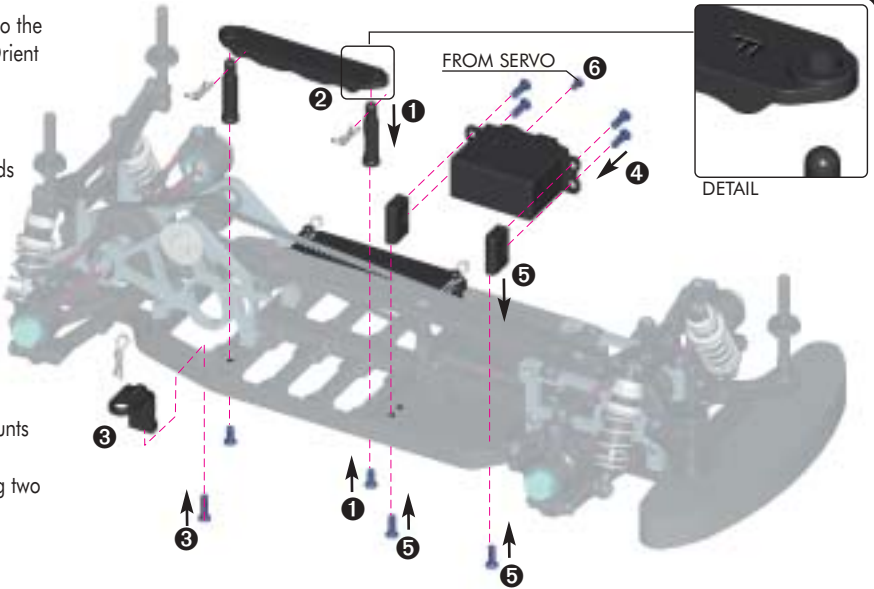

DETAIL



309332
SH M3x5

Mount the spur gear to the layshaft using three #309332 (SH M3x5) screws.



ACCESSORY ASSEMBLY

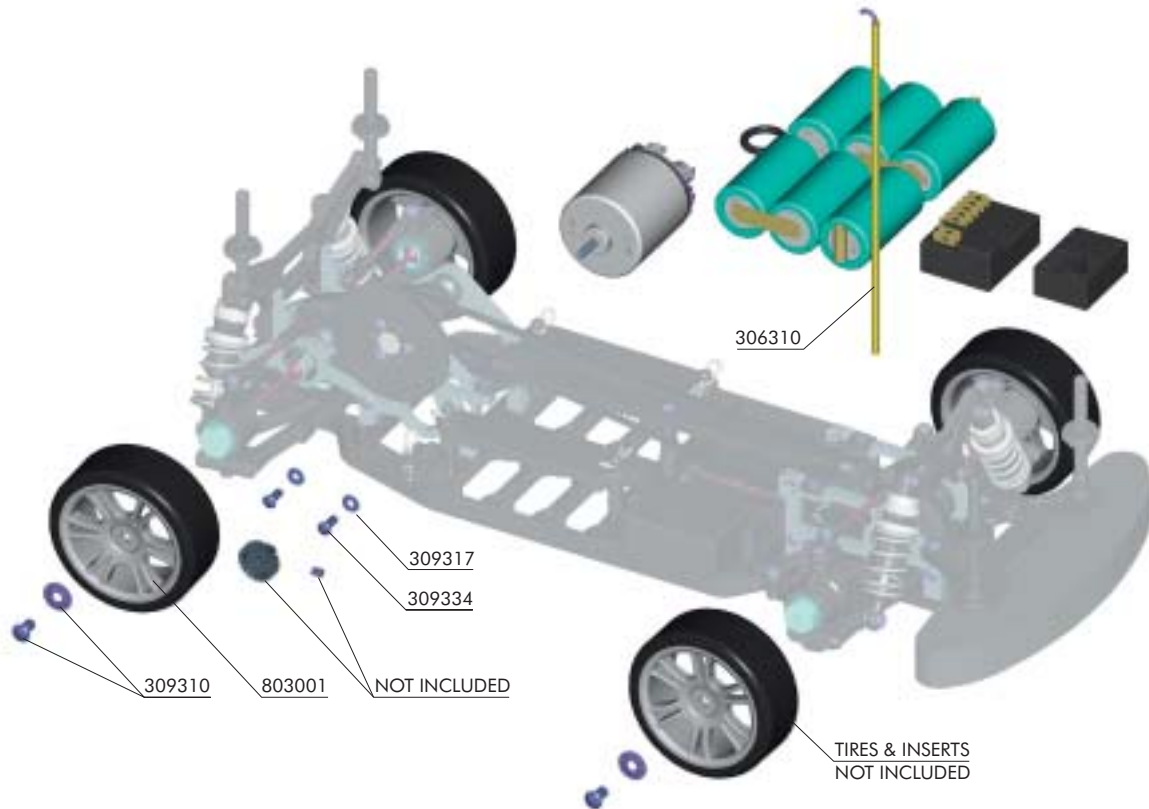

**BAG
09**

30 5720-34 PINION GEAR ALU HARD COATED 48P (OPTION)
 30 6310 ANTENNA (2)
 30 9310 WHEEL MOUNTING HARDWARE (4+4)
 30 9317 WASHER S 3.2 (10)

30 9334 HEX SCREW SH M3x8 (10)
 30 9400 BODY CLIP (8)
 80 3001 HUDY 24 MM WHEELS STARBURST - WHITE (4)



1. Mount the pinion gear to the motor shaft and secure it with a #309350 (SB M3x3) set screw. Note that pinion gear is not included in the kit.
2. Mount the motor to the right rear bulkhead using two #309334 (SH M3x8) screws and #309317 (S 3.2) washers.
3. Adjust the motor so the pinion meshes with the spur gear properly.

Make sure the gear mesh is not too tight. There should be a small amount of play between the teeth of the pinion gear and the spur gear.



Refer to the Set-Up Book to gain a better understanding of gearing and rollout.

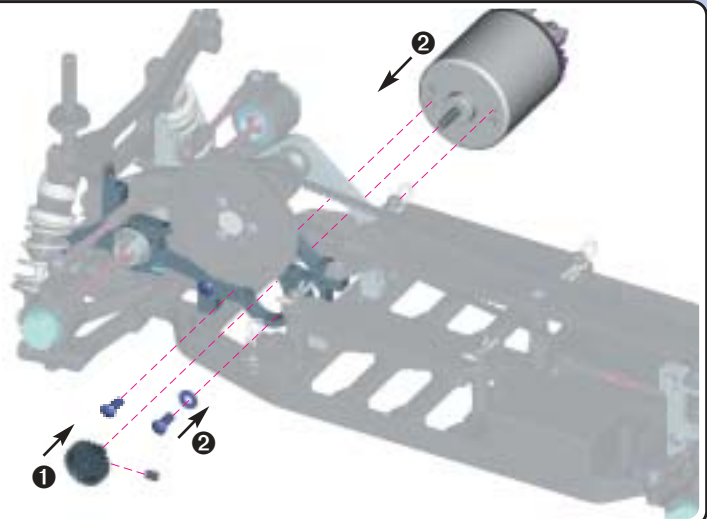

1. Mount the receiver and speed controller on the car using double-sided tape.
2. Pass the receiver's antenna wire through the chassis and then from the bottom of the chassis through integrated antenna mount access hole, and up through the antenna mount.
3. Pass the antenna wire up through the #306310 antenna tube, and then push the base of the antenna tube firmly into the hole of the integrated antenna mount.

Make sure you don't pinch or cut the receiver's antenna wire.

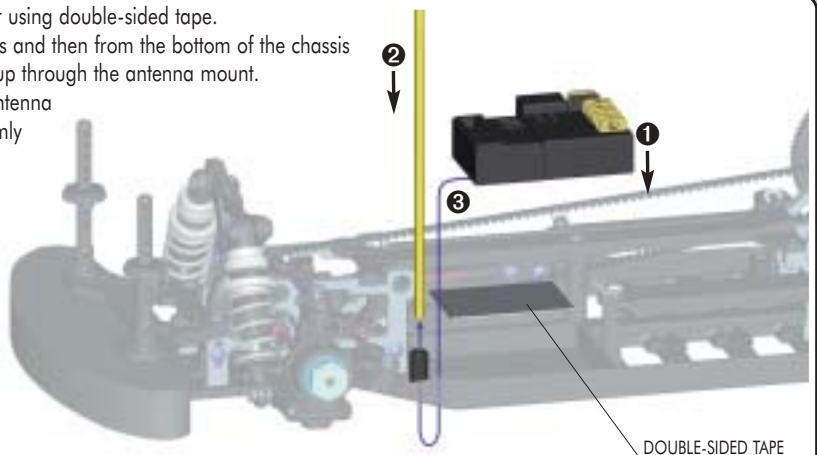
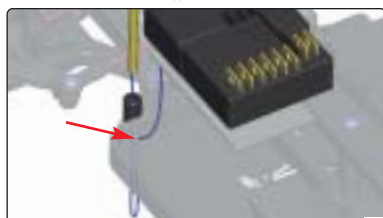

ACCESSORY ASSEMBLY

The XRAY T1R Raycer is a competition racecar, and therefore does not come supplied with tires and inserts. Check with racers at tracks you attend to determine the best tire/insert combinations.

Use your own tires and inserts to prepare the wheels:

1. Install a foam insert into each tire, making sure it is centered.
2. Slide the tire (with insert) onto the wheel.
3. Carefully glue the tires to the wheels with CA glue.

Warning: Follow the adhesive manufacturer's instructions for proper use and safety. Wear proper eye and hand protection.



309310
SH M4x8



309310
ST 4x12

1. Mount the wheels on the wheel axle hex hubs using #309310 (SH M4x8) screws and #309310 (ST 4x12) cone washers. Note the orientation of the cone washer in the detail image. **Make sure the wheel screws are very tight, so the wheels do not loosen during racing.**

This car is designed to use a 6-cell battery pack, configured into 3+3 saddlepacks.

2. Remove the clips from the front of the battery mounting posts, and pivot the battery straps open.
3. Position the battery pack in the chassis cutouts.
4. Reposition the battery straps over the batteries, and secure to the front battery mounting posts with the clips.

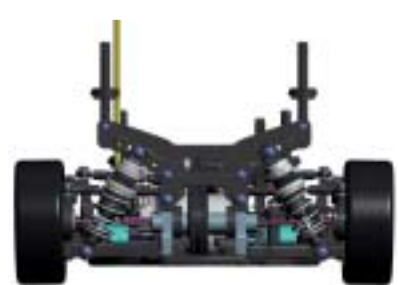
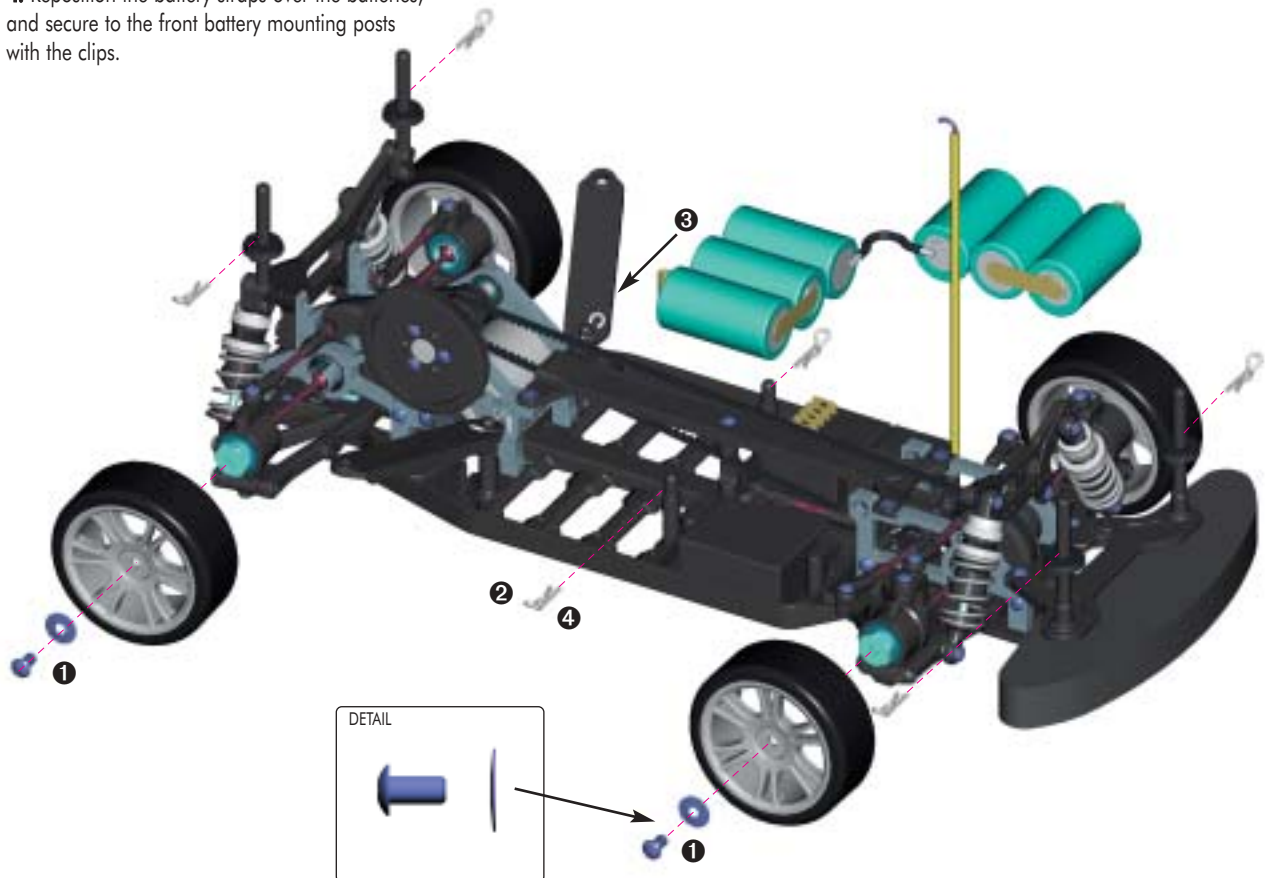

IMPORTANT NOTES:

- This product is not suitable for children except under the direct supervision of an adult.
- Carefully read all manufacturers warnings and cautions for any parts used in the construction and use of your model.
- Assemble this kit only in places away from the reach of very small children.
- First-time builders should seek advice from people who have building experience in order to assemble the model correctly and to allow the model to reach its performance potential.
- Exercise care when using tools and sharp instruments.
- Take care when building; some parts may have sharp edges. Keep small parts out of reach of small children.
- Do not put fingers or any objects inside rotating or moving parts.
- Right after using your model, do NOT touch equipment on the model because they may generate high temperatures.
- Be sure that your operating frequency is clear before running and never share the same frequency with somebody else at the same time.
- Always turn on your transmitter before you turn on the receiver/speed controller or connect the battery pack. Always turn off the receiver/speed controller or disconnect the battery pack before turning your transmitter off.
- Disconnect the battery pack before storing your model.
- When learning to operate your model, go to an area that has no obstacles that can damage your model if you crash.
- Remove any sand, mud, dirt, grass or water before putting your model away.
- Use a recommended charger for the batteries and follow the instructions correctly. Over-charging, incorrect charging, or using inferior chargers can cause the batteries pack to become dangerously hot.
- Do not allow the transmitter batteries to run low, otherwise you risk losing control of the model.
- Regularly check the charger for potential hazards such as damage to the cable, plug, casing or other defects. Ensure that any damage is rectified before using the charger again.
- Do not allow any metal part to short circuit the batteries or speed control.
- If the model behaves strangely, immediately stop the model and check and clear the problem.
- Do not stall the motor. The speed control will fail within seconds if power is applied to the motor when the car cannot move.
- The composite material is sensitive to very high temperatures. Prolonged exposure to very high temperatures will damage the composite and may cause it to deform. For example, do not leave the T1R in a sealed car during hot days.
- Do not use your model:
 - Near real cars, animals, or people that are unaware that an R/C car is being driven.
 - In places where children and people gather
 - In residential districts and parks
 - In limited indoor spaces
 - In wet conditions
 - In the street

Take adequate safety precautions prior to operating this model.

You are responsible for this model's assembly and safe operation.

Disregard of any of the above cautions may lead to accidents, personal injury, or property damage.

XRAY MODEL RACING CARS assumes no responsibility for any injury, damage, or misuse of this product during assembly or operation.

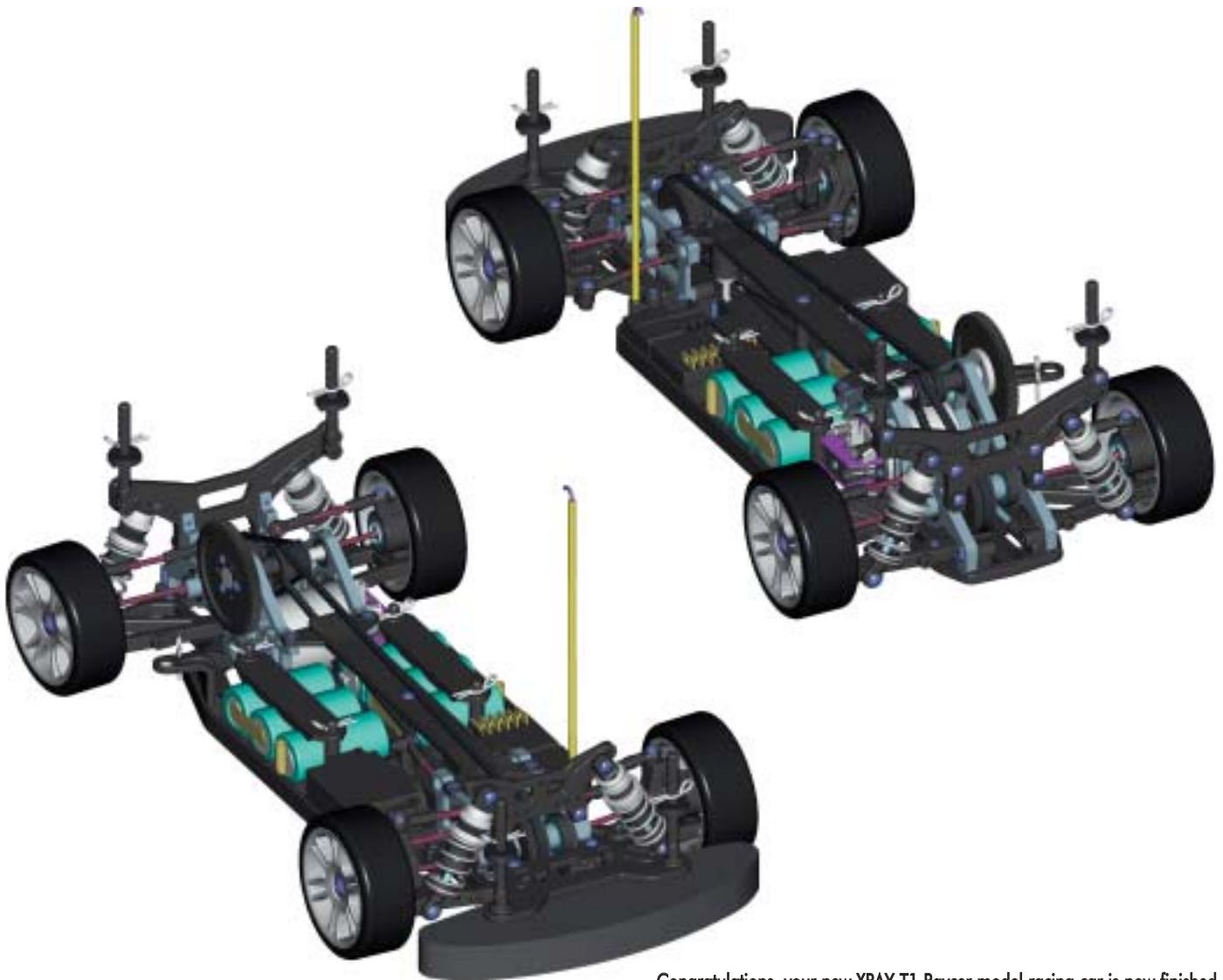

Congratulations, your new XRAY T1 Raycer model racing car is now finished. Proceed to the Set-Up Book to learn about adjusting the suspension geometry.

www.teamxray.com



XRAY MODEL RACING CARS
P.O. BOX 103
911 50 TRENCIN
SLOVAKIA, EUROPE
PHONE: ++421 905 402724
support@teamxray.com