

# OWNER'S MANUAL

MODEL : G620PU  
G620PU-1

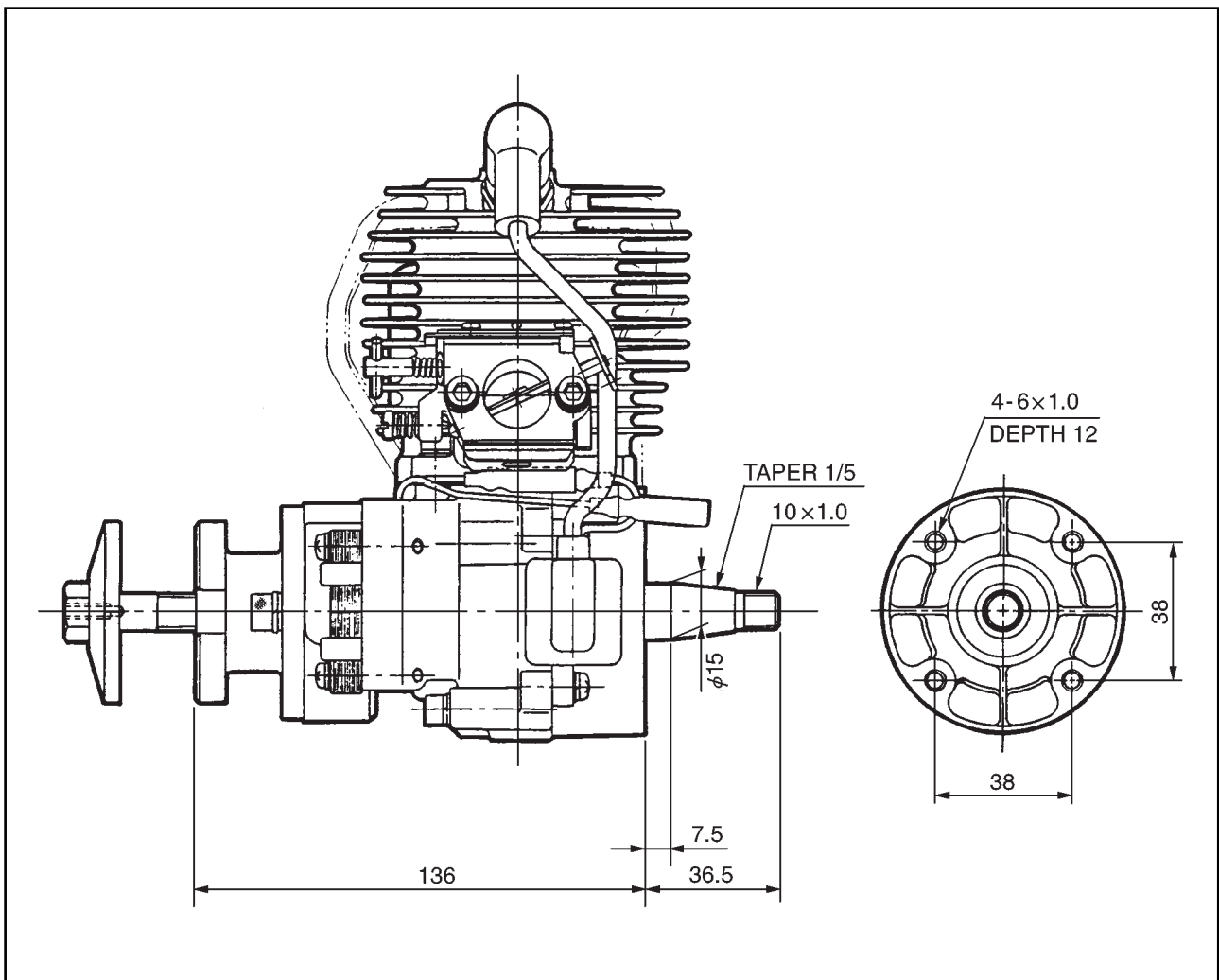

## ⚠ WARNING ⚠

- Do not modify any parts of the engine.
- This engine is designed to be used to Radio controlled products.
- In case any modification by customer, KOMATSU ZENOAH shall not bear any responsibility from the damage caused by such modification.
- Keep ignition system well maintained.

## ⚠ 警告 ⚠

- この製品はラジオコントロール飛行機用に設計されています。
- 改造、組み替えされて使用された場合当社は一切の責任を負いません。
- 特に電装品は常に点検、整備してご使用ください。

## 1. SAFETY PRECAUTIONS

- This manual describes the engine. For its mounting and control, see the instruction manual for a model plane.
- This engine is designed for use on the model plane. If it is used for any other purpose, we cannot be responsible for its reliability or safety.
- Use genuine parts for replacement.
- Check the propeller every time. If it is damaged replace it with a new one.
- If the propeller hits something while the engine is in operation, immediately stop the engine and check it.
- Start the engine on flat surface without pebble stones.
- Never modify the flywheel.
- Check the flywheel. If it is damaged, replace it with a new one.
- When mixing the fuel, or operating the engine, carry it out in a well-ventilated place.

## 2. MOUNTING

Make sure that the engine is mounted on the aircraft grade plywood with more than 10mm of thickness or a mount of equivalent strength and is firmly fixed with 4 bolts.

### [ NOTE ]

1. Be sure to set flat washers or metal plate on the reverse side of the mount to prevent bolts from sinking into the mount.

## 3. PROPELLER

1. Recommended prop size

The recommended prop sizes are as shown in the table below.

Diameter × Pitch (in.)
22 × 6 ~ 8, 20 × 7 ~ 10, 18 × 8 ~ 12

This engine produces the maximum output when the engine is running at about 8,500rpm. Be sure to use a propeller which makes the engine speed approximately 7,000 ~ 9,000rpm while the airplane is flying. When using a propeller

of small diameter, a light weight propeller is not suitable.

2. The mounting bolts should be screwed into the crankcase within 8 ~ 12 mm of depth.
3. Since this engine is equipped with a float-less carburetor with a diaphragm pump, the direction of cylinder and position of fuel tank can be freely selected.

### [ NOTE ]

1. When mounting a thin propeller, cut off the end of bolt or add a flat washer.
2. When mounting the spinner, set a pin on the hub with more than 3 mm of diameter, thus preventing slipping.

## 4. FUEL

Mix gasoline and 2-stroke oil at a mixing ratio of 25 ~ 40 : 1.

### [ NOTE ]

1. Be sure to use a gasoline-resistant fuel piping. (Do not use any silicon rubber tube).

2. Never use any alcohol fuel or alcohol added fuel, or the rubber part in the carburetor will be damaged.

## 5. OPERATION

### Hand flip start

Since the engine is equipped with the ultra compact C.D.I. type flywheel magneto ignition system, it should be started according to the following procedure;

- \* The magneto system of the engine is designed in such a way that when the exhaust port is closed by the piston, that is, when the compression stroke starts (Refer to Fig.1-A), sparks are never produced on spark plug no matter how fast the propeller may be flipped. Be sure to quickly flip the propeller when the edge of magnet on the rotor is approaching the coil (Fig. 1-B). It means that the propeller should be quickly flipped about 90 degrees in crank angle before the compression is about to start.

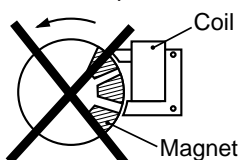

Fig.1-A

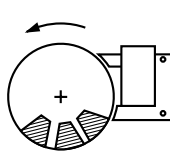

Fig.1-B

- \* Because of the above conditions the propeller should be mounted to the hub as shown in (Fig. 2) and quickly flipped within the range of about 180° from the horizontal position.

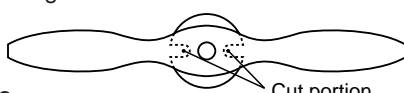

Fig.2

The cut portions of propeller mount and the propeller should be set in the same direction.

### [ NOTE ]

When the engine is mounted so the cylinder is kept horizontal, the propeller should be set at a different angle of 90°.

### How to Start the Engine

1. Fill the fuel tank with the fuel.
2. Close the choke valve and open the throttle valve approximately 1/3 ~ 1/2 of the full open position.
3. Quickly flip the propeller in the counterclockwise direction according to the procedure described above. When flipped several times, the sound (popping sound) of initial explosion is heard.
4. When the initial explosion is heard, open the choke valve, set the throttle valve at the idle position or at the position slightly open from the idle position and flip the propeller a few more times. Then, the engine starts.

### [ NOTE ]

- Be sure to open the choke when the initial explosion is heard.
- When the choke is opened, be sure to close the throttle valve to a position near the idle position before starting the next flipping (If the engine is started while the throttle is wide open, a great thrusting force is produced, which is very dangerous).
- Be sure to wear a thick glove when flipping the propeller. Use all fingers, except thumb, for the flipping operation.

## How to Stop the Engine

For stopping the engine, the black lead wire from the coil should be grounded to the engine body, or the throttle valve should be closed completely.

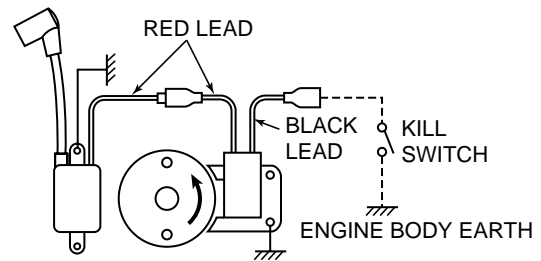

## 6. CARBURETOR ADJUSTMENT

The carburetor is provided with 3 adjust screws which are set to the best (approximately) positions by our company, but they may need a little adjustment depending on the temperature, atmospheric pressure (altitude), etc. of the area where the engine is used. Start the engine without making any adjustments. Make readjustments only when the engine shows any mal-functioning.

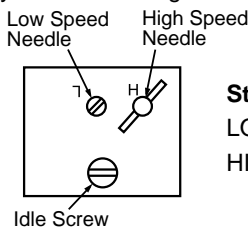

### Standard Opening Position :

LOW SPEED NEEDLE :  $1\frac{1}{2} \pm \frac{1}{4}$

HIGH SPEED NEEDLE :  $1\frac{1}{4} \pm \frac{1}{4}$

### [ NOTE ]

Be sure to stop the engine before starting the adjustment, thus ensuring safety.

**Idle Screw:** Turning this screw clockwise increases the idling R.P.M. Turning it counterclockwise decreases the idling R.P.M.

**Low Speed Needle:** This is the fuel adjust screw (not the air screw). Turning this needle clockwise makes the mixture gas leaner and turning it counterclockwise makes it richer.

**High Speed Needle:** Turning this needle clockwise makes the mixture gas leaner and turning it counterclockwise makes it richer. Set this needle at a position which is  $\frac{1}{4}$  open from the maximum R.P.M. position while the airplane is on ground.

### [ NOTE ]

1. Do not tighten the High and Low Speed needles too firmly.
2. When the unit has just started and the engine is not warm enough, there may be insufficient acceleration and the engine may be stopped. Be sure to perform idling before operation.

## 7. ENGINE BREAK-IN

No specific break-in is required. The engine is gradually getting break-in as it is used and the output is also increased gradually.

## 8. MAINTENANCE

This engine is used for power source for radio controlled airplane so you are strictly requested to check engine and relative parts of airplane.

### 1) Daily check (before starting)

- Leakage, damage, crack
- Muffler fixing bolts (torque, crack)
- Propeller hub (transformation, fixing bolts/nut)  
(P/N: 2629-51410 or 2629-91510, 3544-11510 and 1100-43231)

- Rotor (transformation, play, airgap)

### 2) Every 25 hours check

- Spark plug (gap, cleaning)
- Cylinder (abrasion)
- Piston/Ring (abrasion)
- Bearing (Gritty)

According to the checks, replace any part if necessary.

## 9. SERVICING

The engine can be disassembled or reassembled without any specific difficulties, but be careful of the following matters;

**a.** For disassembling, the special tools shown in the parts list are required in addition to the general tools. Be sure to use a new gasket when the crankcase and cylinder have been disassembled.

### b. Removing rotor

1. Screw in the stopper (P/N:3350-96220) in place of the spark plug. Then turn the rotor counterclockwise until the piston touches the stopper. Take care it can cause damage to the piston or connecting rod if the stopper is not screwed in to the bottom.
2. Loosen and remove the rotor securing nut.
3. Remove the rotor by using the puller (P/N:1490-96101). Do not hit on the crankshaft by a hammer, that can increase the runout of the shaft.

### c. Assembling crankcase

1. Apply grease on the oil seal lips and oil on the bearing.
2. Assemble the crankshaft with a new gasket.
3. When both front and rear crankcases are tightened, the portion of gasket protruding on the cylinder mounted surface should be cut off with a knife until the gasket

becomes flush with the cylinder mounted surface.

### d. Assembling piston

Before assembling the piston, apply the oil on the small end bearing and piston, and set the piston ensuring that the arrow mark on the top of piston is directed toward the direction of exhaust port.

### e. Assembling cylinder

1. Coat the oil on the inner surface of cylinder.
2. The piston is provided with a knock pin which stops the piston ring from turning. Set the splitted section of piston ring at the knock pin and assemble the cylinder ensuring not to break the piston ring.

### f. Assembling rotor

Make sure to put lock tight (Medium strength type: TreeBond 1322N, LOCTITE 242,243, PACER ZAP Z-42) on the rotor fixing nut (P/N:1100-43231).

### g. Adjusting air gap of coil.

The air gap of coil should be adjusted to 0.3 mm (0.01").

### h. Adjusting ignition time.

This engine with the point-less C.D.I. type requires no adjustments of ignition time.

## 10. SPECIFICATIONS

Model	G620PU · G620PU-1
Type	Air cooled two stroke cycle gasoline engine
Displacement	62.0cc (3.78cu. in)
Bore × Stroke	47.5mm × 35mm (1.87 in × 1.38 in)
Compression ratio	8.2 : 1
Maximum Output	5.4PS/9500rpm [4.7 PS/9500rpm with Muffler]
Operating engine speed	2000 ~ 10000rpm
Weight	2.0kg (4.4lbs) [2.3kg (5.1lbs) with muffler]
Ignition system	CDI type Flywheel magneto
Carburetor	WALBRO HDA-48D
Fuel	Gasoline oil mixture 25 ~ 40 : 1
Spark plug	CHAMPION RCJ-7Y
Recommended prop sizes (inch)	22 × 6 ~ 8, 20 × 7 ~ 10, 18 × 8 ~ 12

Specifications are subject to change without notice.

## 11. PARTS LIST

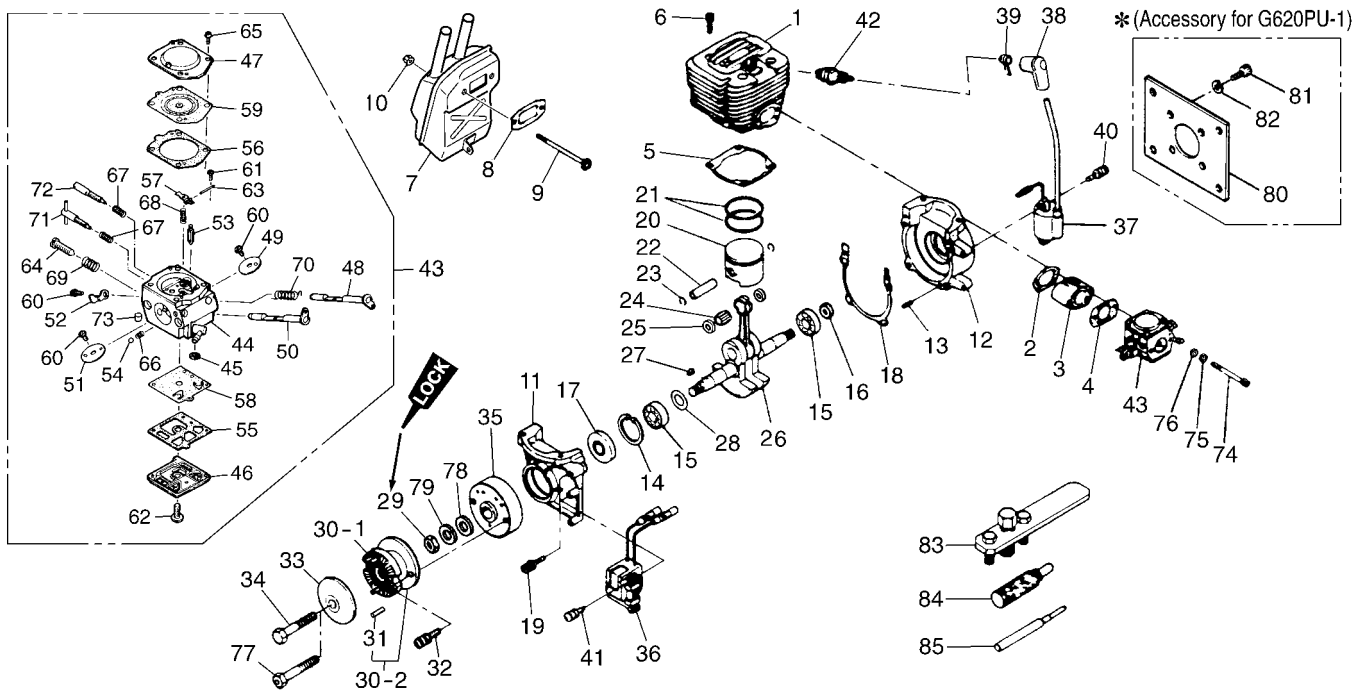

Index No.	Parts No.	Description	Q' ty /unit	Index No.	Parts No.	Description	Q' ty /unit	Index No.	Parts No.	Description	Q' ty /unit
1	3366-12115	Cylinder	1	30-2	2629-51111	Hub,propeller comp. for G620PU-1	1	59	3350-81270	• Diaphragm assy	1
2	2616-14111	Gasket,insulator	1	31	04025-00312	• Pin for G620PU-1	2	60	3310-81360	• Screw, valve	3
3	2618-14120	Insulator	1	32	3544-11510	Bolt	2	61	3310-81240	• Screw, metering lever	1
4	2618-14131	Gasket,carburetor	1	33	2629-51310	Washer,hub	1	62	1491-81130	• Screw, pump cover	1
5	2616-14211	Gasket,cylinder base	1	34	2629-51410	Bolt	1	63	3310-81250	• Pin, metering lever	1
6	3310-12281	Bolt	4	35	1490-71110	Rotor	1	64	2630-81330	• Screw, idle speed	1
7	2629-15111	Muffler	1	36	2629-71210	Source coil	1	65	3310-81351	• Screw assy	4
8	3356-15210	Gasket,muffler	1	37	2629-71311	Ignition coil	1	66	3350-81350	• Spring, friction	1
9	T2100-15220	Bolt	2	38	2629-72210	Cap,plug	1	67	1491-81160	• Spring, needle adjust	2
10	3356-15230	Nut	2	39	1400-72121	Spring,plug cap	1	68	3350-81370	• Spring, metering lever	1
11,12	2629-21100	Crankcase comp.	1	40	0263-30416	Screw	2	69	3350-81380	• Spring, idle speed	1
13	2629-21130	Pin	3	41	0260-30422	Screw	2	70	2629-81390	• Spring, throttle return	1
14	04065-03515	Snap ring	1	42	1630-73110	Spark plug	1	71	2629-81411	• needle, high speed	1
15	06030-06202	Bearing	2	43	2629-81004	Carburetor assy, HDA-48D	1	72	2629-81420	• needle, idle	1
16	1520-21220	Oil seal	1	44		• Body assembly	1	73	3304-81420	• plug, welch	1
17	1400-21220	Oil seal	1	45	3306-81380	• Screen, inlet	1	74	2629-82210	Bolt	2
18	2629-21311	Gasket,crankcase	1	46	3350-81130	• Cover, pump	1	75	01641-20508	Washer	2
19	3350-21320	Bolt	4	47	3350-81140	• Cover, diaphragm	1	76	01601-20513	Washer	2
20	2618-41112	Piston	1	48	2629-81150	• Shaft assy, throttle	1	77	2629-91510	Bolt	1
21	2618-41210	Ring,piston	2	49	3366-81340	• Valve, throttle	1	78	01641-21016	Washer	1
22	3366-41310	Pin,piston	1	50	3356-81170	• Shaft assy, choke	1	79	0290-21025	Washer	1
23	3350-41320	Snap ring	2	51	2629-81180	• Valve, choke	1	80	2628-91110	Mount	1
24	1400-41410	Needle bearing	1	52	3350-81190	• Stop, throttle	1	81	01252-30614	Bolt	4
25	2616-41510	Thrust washer	2	53	3356-81310	• Valve, inlet	1	82	0290-20615	Washer	4
26	2629-42002	Crankshaft comp.	1	54	3350-81220	• Ball, friction	1	83	1490-96101	Puller assy (Optional)	1
27	1000-43240	Key	1	55	3350-81230	• Gasket, pump	1	84	3350-96220	Stopper (Optional)	1
28	1300-42410	Sim	0~2	56	3350-81240	• Gasket, diaphragm	1	85	3356-96230	Guide, piston pin (Optional)	1
29	1100-43231	Nut	1	57	3350-81250	• Lever, metering	1				
30-1	2628-51101	Hub,propeller comp. for G620PU	1	58	2618-81260	• Diaphragm, pump	1				

**KOMATSU ZENOAH CO.**

Head Office : 1-9 Minamidai, Kawagoe-city,  
Saitama, 350-1192 Japan  
Phone: (+81)492-43-1117 Fax: (+81)492-43-7197

Printed in Japan